

The Baldor Super-E®

In the mid-70s, a southeastern tire manufacturing plant asked Baldor to increase their plant's operating efficiencies. After analyzing the efficiencies of the plant's 75 Hp motors, Baldor engineers determined that considerable energy savings could be gained from a motor design focused on "active materials." By adding more copper to the windings, upgrading the laminations to a premium-grade steel, designing precision air gaps between the rotor and stator, and reducing fan and other losses in the motor, Baldor was able to supply the plant with the premium efficient motors it needed. This was the birth of the Baldor Super-E®.

Over 1,000 Stock Motor Ratings

Today's line of Baldor Super-E motors offers customers some from the highest levels of efficiencies, in ratings of 1 to 15,000 horsepower. Baldor has ratings available immediately from stock, with non-stock motors with the industry's shortest load times. All Super-E motors (except Explosion-Proof) are also "Inverter-Ready".

The Right Premium Efficient Motor for your Application

Whether it's a premium efficient motor for harsh, outdoor conditions at a petro-chemical plant, or for continuous duty in a distribution center, Baldor offers customers a variety of choices.

Super-E Totally Enclosed Fan Cooled (TEFC) and Open Drip Proof (ODP) are reliable motors that have kept plants operating efficiently since their introduction in 1983. Explosion-Proof, Close Coupled Pump and Automotive Approved Super-E's deliver premium efficiency for special applications.

In applications requiring added protection from corrosion caused by severe environmental operating conditions, Baldor•Reliance Super-E Severe Duty motors are available in TEFC ratings from 1 through 2250 Hp. Cast-iron construction, epoxy primer and finish paint inside and out, gaskets on all joints and many other features provide added protection where and when you need it most.

For the ultimate in protection from severe environments – where you need added insurance against downtime – Baldor offers IEEE 841 motors. Delivering reliable, rugged performance with the industry's highest energy efficiencies, these motors exceed IEEE 841 - 2001 standards for severe duty TEFC induction motors. Inpro/Seal® bearing isolators at both the drive end and fan end. Baldor IEEE 841 motors are available immediately off the shelf, in 1 - 250 Hp ratings, with special designs available as custom motors.

Leadership in Premium Efficiency

Called a "key breakthrough" by the Consortium for Energy Efficiency, the CEE in 1998 recognized Baldor's Super-E as the first premium efficient motor line to meet their stringent efficiency criteria, citing "For the first time, one manufacturer will carry all qualifying products."



A Baldor Super-E motor and Inverter Control provide premium energy efficiency and improved process control to a municipal water treatment facility.

Minimum Efficiency Performance Standards (MEPS) for electric motors are becoming commonplace throughout the world. The first of these was the Energy Policy Act of 1992 (EPA) that mandated efficiency levels for 1-200 Hp general purpose motors for sale in the U.S. after October 1997. The Energy Independence and Security Act of 2007 (EISA) builds upon EPA and raises the efficiency level for these motors to NEMA Premium® efficiency and adds other configuration and 201-500 Hp ratings for MEPS compliance. Baldor•Reliance Super-E motors manufactured today meet or exceed EISA requirements.

As countries and regions across the world establish minimum efficiency levels for motors, more companies are turning to the Baldor•Reliance Super-E. This includes plant and processing applications, as well as OEM products for shipment overseas. Super-E motors meet or exceed the efficiency levels defined by The Energy Independence & Security Act of 2007 (EISA) in the U.S., NRC in Canada, and IEC 60034-30 IE3 level in Europe. Super-E motors meet or exceed NEMA Premium® efficiencies.

A wide selection of premium efficient motors, available from stock, manufactured and sold by a company committed to building better products for industries worldwide. No wonder, since the 1920s, Baldor•Reliance is recognized as the leader in energy efficient industrial motors and drives.



Super-E® Premium Efficiency Motor Construction

The family of Baldor•Reliance Super-E TEFC (Totally-Enclosed Fan-Cooled) motors shares a number of electrical and mechanical features that add up to outstanding value. “EM” motors are general-purpose premium efficient motors. For more severe environmental applications, our “ECP/XEX” Severe Duty motors provide added weather and chemical protection. For extreme applications, where downtime is critical, Baldor “841XL” motors are ideal; these motors exceed IEEE 841-2001 specifications.

The chart below lists standard features (“S”) in Baldor’s TEFC Premium Efficient motors. Horsepower ranges indicate where certain features are standard in stock products. Additional features optional (“O”) on custom motors, or through Baldor’s Mod-Express.

TEFC Premium Efficiency Motor Family

Electrical Features	EM / XE	ECP/XEX	841XL
Hp Range - Stock	1-1000	1-1000	1-250
Class F insulation with Class B rise	S	S	S
1.15 Service factor	S	S	S
200°C Inverter Spike Resistant insulation system	S	S	S
Phase insulation	S	S	S
Corona inception testing - meets NEMA Part 31.4.4.2	S	S	S
Varnish dip & bake with 100% solids	S	S	S
No silicone lead wire		S	S
Documented final motor tests - data shipped with motor	O	O	S
Mechanical Features			
NEMA Frame sizes	143T - 449T	143T - 449T	143T - 449T
Steel Band Frame Die cast aluminum endplates, steel fan cover	S 143T - 215T		
Cast iron frame - cast iron endplates & fan cover (steel fan cover standard on EM/XE 140-280T)	O 143T - 286T S 324T - Up	S	S
Die cast aluminum conduit box	S thru 360T		
Cast Iron conduit box	S 400T - up	S	S
Threaded inlet hole in conduit box		S	S
Neoprene conduit box lid gasket & lead separator gasket		S	S
Seal endplate to frame joints		S	S
V-ring shaft seals - DE & ODE (except some 440 frame)	S 250T - up DE only	S	
Inpro/Seal® VBX or VBXX bearing isolators - DE and ODE			S
Hardware - zinc plated	S	S	S
Motor unfiltered vibration at rated voltage and frequency <0.15 in/sec peak velocity	S	S	
Motor unfiltered vibration at rated voltage and frequency <0.08 in/sec peak velocity			S
Test vibration on DE & ODE and document - ship with motor			S
Low bearing temperature specs (IEEE 841)			S
Foot flatness to < NEMA tolerances (0.005"/ft.)			S
Shaft runout < NEMA			S
Sound power level < 90 dBA			S
Grease inlet fitting - grease fitting	S		
Grease inlet and grease fitting		S	S
Grease outlet with screw-in plug	S		
Grease outlet with automatic relief fitting	S 250T - up		
Grease outlet and automatic relief fitting		S	S
Non-metallic external cooling fan	S	S	S
Casting coated with water base primer	S		
Castings coated with 2-part epoxy primer and epoxy finish coat		S	S
Finish paint with gold enamel	S		
Finish paint with 2-part blue-green epoxy		S	S
ASTM B117-90 96-hour salt spray test compliance		S	S
Laser etched aluminum nameplate with NEMA data	S		
Embossed Stainless steel nameplate with NEMA data		S	S
Stainless steel nameplate with bearing and grease data		S	S
Limited Warranty	3 year	3 year	5 year

Note: Contact your Baldor District Office for certified data, dimensions and features of a specific motor.

Baldor Super-E®: Premium efficiency inside and out

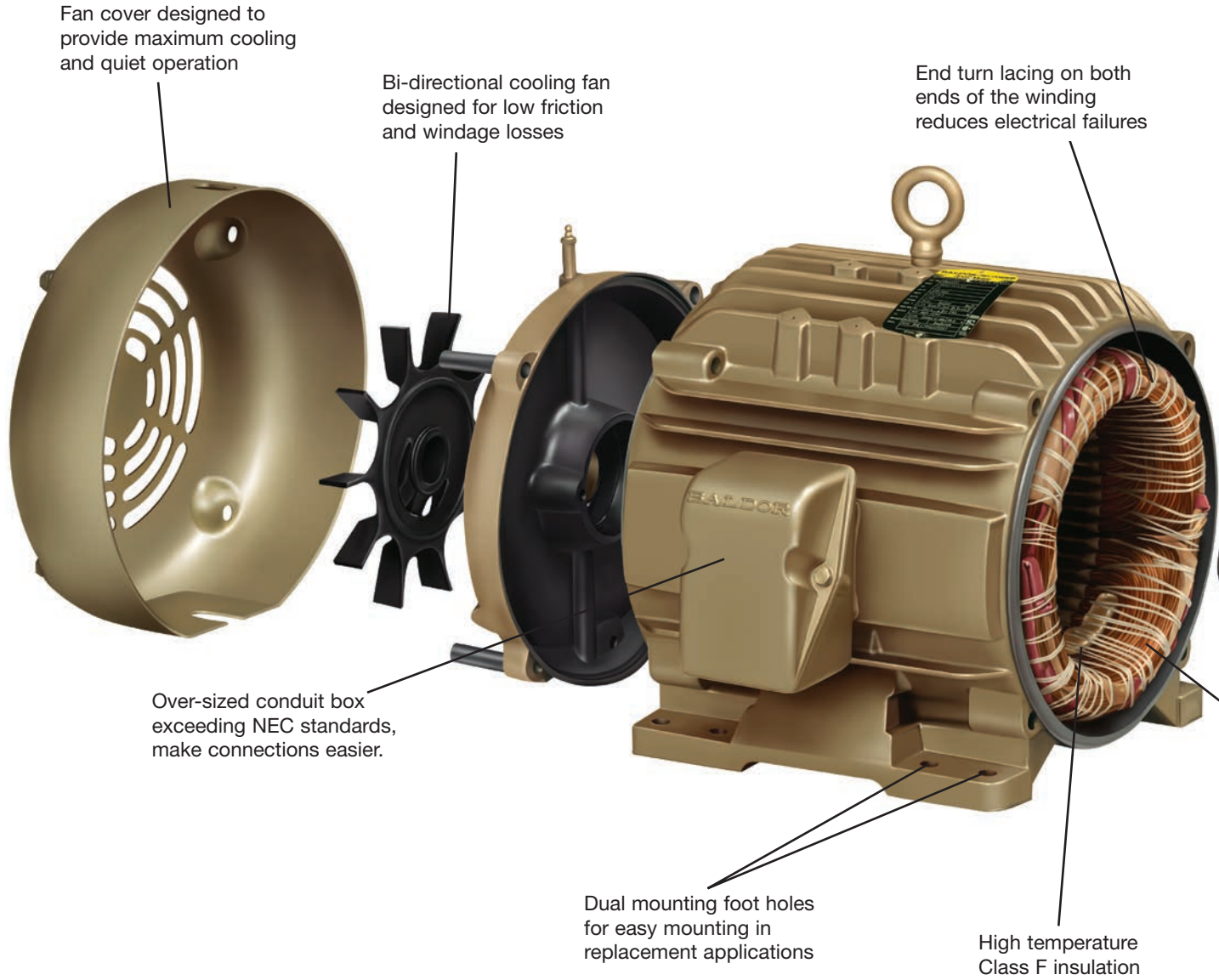

All Baldor•Reliance Super-E® motors meet or exceed NEMA Premium® efficiency requirements per NEMA MG 1 table 12-12.

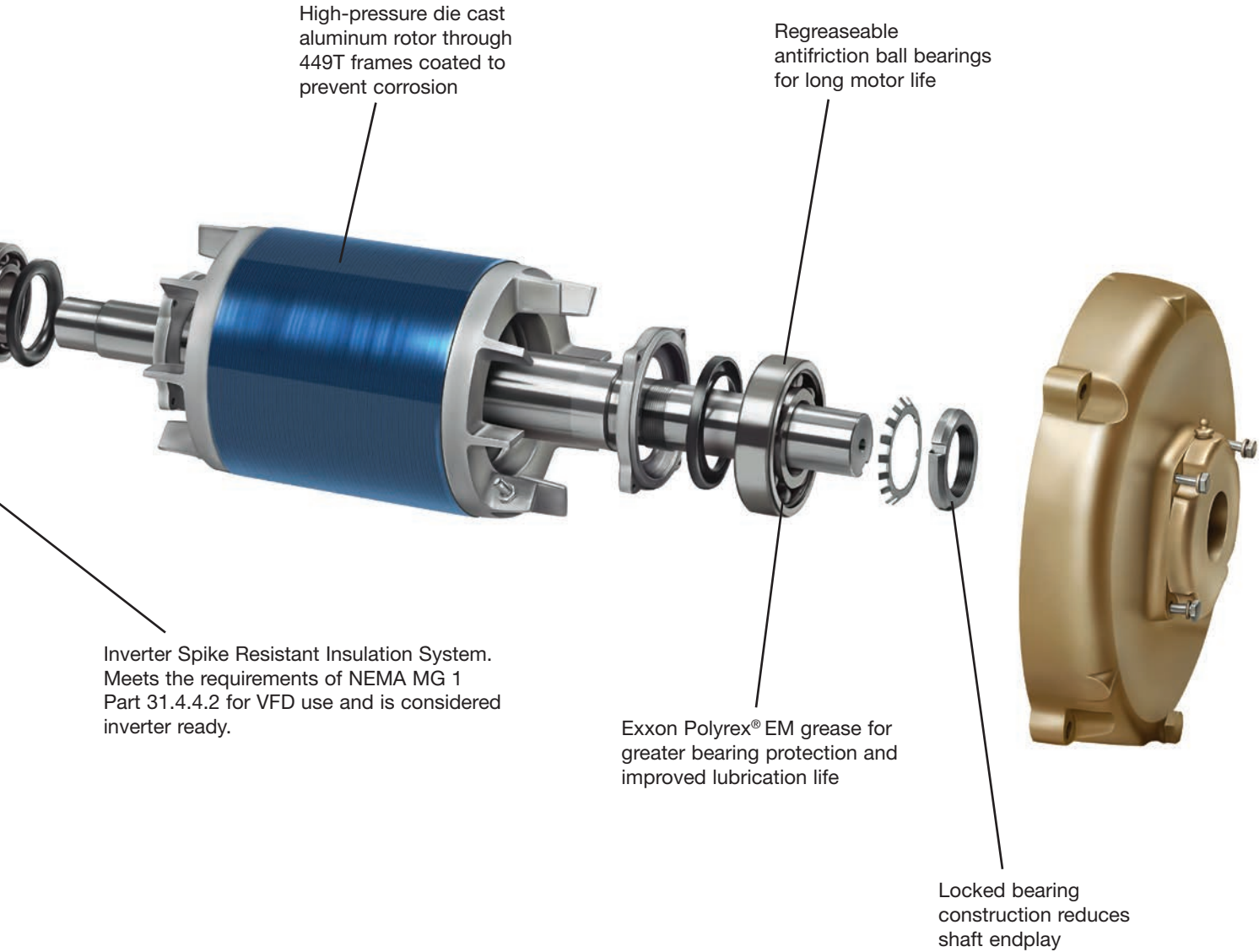

TEFC - Super-E® Capabilities

Three Phase

Three Phase - Typical Frame Size / Speed - RPM

Hp	3600	1800	1200	900
1	56	56, 143T or 182	56 or 145T	182T
1.5	143T	56, 145T or 184	145T or 182T	184T
2	145T	56, 145T or 184	184T	213T
3	145T, 182T or 184	182T or 213T	213T	215T
5	184T	184T or 215T	215T	254T
7.5	184T or 213T	213T	254T	256T
10	215T	215T	256T	286T
15	254T	254T	284T	286T
20	256T	256T	286T	324T
25	284TS	284T	324T	326T
30	286TS	286T	326T	364T
40	324TS	324T	364T	365T
50	326TS	326T	365T	404T
60	365TS	364T	404T	405T
75	365TS	365T	405T	444T
100	405TS	405T	444T	445T
125	444TS	444T	445T	447T
150	447TS or 449T*	445T or 449T*	447T or 449T*	449T or 5008*
200	447TS or 449T*	447T or 449T*	449T or 5008*	5008*
250	449TS or 5008*	449T or 5008*	449TY or 5008*	5010*
300	449TS or 5008*	449TY or 5008*	449TY or 5010*	5010*
350	449TS or 5008*	449TY or 5008*	5010*	5012*
400	449TS or 5010*	5008*	5012*	5012*
450	5010*	5010*	5012*	5012*
500	5010*	5010*	5012*	5012**
600	5010*	5012*	5012**	5800*
700	5800*	5012*	5800*	5800*
800	5800*	5012*	5800*	G500S**
900	5800***	5012**	G500S**	G500S**
1000	G500M***	5800*	G500S**	G500S**
1250	G500M***	5800*	G500S**	G500M**
1500	G500M***	G500M**	G500M**	G500M**
1750	•	G500M**	G500M**	•
2000	•	G500M**	•	•
2250	•	G500M**	•	•

NOTE: Shaded area denotes product scope of NEMA Premium® efficiency motor program.

- Rating available in other enclosure
- * Medium Voltage (2300 or 4000V)
- ** Medium Voltage (2300 or 4000V), Fabricated Copper Bar Rotor required.
- *** Medium Voltage (2300 or 4000V), Sleeve Bearings and Fabricated Copper Bar Rotor required.

Motors listed with catalog numbers in this brochure are available from stock. Contact Baldor for lead times on non-stock motors.

Performance data is subject to change. Drawings shown are for reference only. Please contact Baldor for current performance data or a detailed drawing on the specific motor you require. Data and drawings may be available from our website at www.baldor.com.

Premium Efficiency in Metric Frames

Baldor Super-E® motors are available in IEC frames 63 through 500 with base, B5 flange or B14 C-face. Motors can be supplied for 50 or 60 Hz operation. Contact your Baldor•Reliance District Office for more information.

Premium Efficient Super-E® Washdown Motors



For multi-shift food and pharmaceutical processing applications, Baldor•Reliance Washdown Duty motors deliver both reliability and energy cost savings. The standard in the food and pharmaceutical processing industries for more than 25 years, Baldor Washdown Duty motors continually raise the bar with more features to improved reliability. The improved exterior paint process makes the finish coat five times more resistant to corrosion and chipping. Mobil Polyrex® EM grease provides improved lubrication life, provides greater shear stability and superior resistance to washout, rust and corrosion. Distinctive black drain plugs make them easy to recognize and are easily removable.



TEFC - Totally Enclosed Fan Cooled, TENV - Totally Enclosed Non-Ventilated 230/460 Volts, Three Phase, 1 - 20 Hp

Hp	kW	RPM	Frame	Encl.	Catalog No.	Amps @ High V		Full Load Torque Lb. Ft.	Efficiency %			Power Factor %			Bearings		Volt Code	"C" Dim.	Conn. Diag. No.
						Full Load	Locked Rotor		1/2	3/4	Full Load	1/2	3/4	Full Load	DE	ODE			
Foot Mounted																			
1	0.75	1745	143T	TENV	EWDM3546T	1.5	13.5	3.02	83.4	85.4	85.5	53	67	76	6205	6203	E	12.12	CD0005
1 1/2	1.1	1755	145T	TENV	EWDM3554T	2.1	20	4.45	87	88.3	88.8	54	68	76	6205	6203	E	13.00	CD0005
2	1.5	1755	145T	TEFC	EWDM3558T	2.9	24.3	5.95	84.2	86.4	87.3	51	64	73	6205	6203	E	14.17	CD0005
3	2.2	1760	182T	TEFC	EWDM3611T	4.2	32	8.88	87.8	89.5	89.6	54	68	75	6206	6205	E	16.54	CD0005
5	3.7	1750	184T	TEFC	EWDM3615T	6.7	49.1	14.9	89.7	90.3	89.8	60	72	78	6206	6205	E	18.04	CD0005
7 1/2	5.6	1770	213T	TEFC	EWDM3710T	9.4	70.1	22.4	92.2	92.7	92.2	63	75	81	6307	6206	E1	19.04	CD0005
10	7.5	1770	215T	TEFC	EWDM3714T	12	103	29.5	92.1	92.4	91.8	66	79	85	6307	6206	F	20.54	CD0005
C-Face Foot Mounted																			
1	0.75	3450	56C	TEFC	CEWDM3545	1.4	9	1.5	67.8	73.5	75.1	74	81	85	6205	6203	F	12.24	CD0005
1	0.75	1745	56C	TENV	CEWDM3546	1.5	13.5	3	83.4	85.4	85.5	53	67	76	6205	6203	E	12.06	CD0005
1	0.75	1745	143TC	TENV	CEWDM3546T	1.5	13.5	3.02	83.4	85.4	85.5	53	67	76	6205	6203	E	12.12	CD0005
1	0.75	1155	56C	TEFC	CEWDM3556	1.8	10.8	4.51	79.4	82.3	82.7	43	55	64	6205	6203	E	13.24	CD0005
1 1/2	1.1	3500	56C	TENV	CEWDM3550	2	23.5	2.3	82.5	85.2	86.1	71	81	87	6205	6203	E	12.06	CD0005
1 1/2	1.1	1755	145TC	TENV	CEWDM3554T	2.1	20	4.45	87	88.3	88.8	54	68	76	6205	6203	E	13.00	CD0005
2	1.5	3490	56HCY	TEFC	CEWDM3555	2.5	25.9	2.98	83.5	85.9	86.4	75	84	88	6205	6203	E	13.24	CD0005
2	1.5	3490	145TC	TEFC	CEWDM3555T	2.5	25.9	2.98	83.5	85.9	86.4	75	84	88	6205	6203	E	13.28	CD0005
2	1.5	1755	145TC	TEFC	CEWDM3558T	2.9	24.3	5.95	84.2	86.4	87.3	51	64	73	6205	6203	E	14.16	CD0005
2	1.5	1750	145TC	TENV	CEWDM3558T	2.7	25	5.95	88.5	89.5	89.1	60	72	80	6205	6203	E	14.37	CD0005
2	1.5	1175	184TC	TEFC	CEWDM3614T	3.5	27.5	8.91	85.3	88.0	88.9	40	52	60	6206	6205	E	18.04	CD0005
3	2.2	3450	145TC	TEFC	CEWDM3559T	3.5	39.2	4.59	87.7	88.3	87.6	81	88	92	6205	6203	F	15.55	CD0005
3	2.2	3450	182TC	TEFC	CEWDM3610T	3.6	33.1	4.61	87.9	88.2	87.2	81	88	92	6206	6203	E	15.18	CD0005
3	2.2	1760	182TC	TEFC	CEWDM3611T	4.2	32	8.88	87.8	89.5	89.6	54	68	75	6206	6205	E	16.54	CD0005
3	2.2	1160	213TC	TEFC	CEWDM3704T	4.6	34.4	13.4	87.7	89.4	89.5	49	61	68	6307	6206	E	19.78	CD0005
5	3.7	3450	184TC	TEFC	CEWDM3613T	5.9	57.2	7.64	88.4	89.1	88.3	81	88	91	6206	6205	E	16.54	CD0005
5	3.7	1750	184TC	TEFC	CEWDM3615T	6.7	49.1	14.9	89.7	90.3	89.8	60	72	78	6206	6205	E	18.04	CD0005
5	3.7	1160	215TC	TEFC	CEWDM3708T	7.3	51.6	22.7	89.8	90.4	89.7	55	66	73	6307	6206	E	20.53	CD0005
7 1/2	5.6	3450	184TC	TEFC	CEWDM3616T	8.4	91	11.4	90.6	90.7	89.8	85	90	93	6206	6205	E	18.04	CD0005
7 1/2	5.6	3520	213TC	TEFC	CEWDM3709T	9	68.4	11.2	88.8	90.5	90.6	69	79	84	6307	6206	E	18.64	CD0005
7 1/2	5.6	1770	213TC	TEFC	CEWDM3710T	9.4	70.1	22.4	92.2	92.7	92.2	63	75	81	6307	6206	E1	19.78	CD0005
7 1/2	5.6	1180	254TC	TEFC	CEWDM22976T	11	75.8	33.2	90.3	91.6	91.3	51	63	70	6309	6208	E	23.57	CD0005
10	7.5	3490	215TC	TEFC	CEWDM3711T	11.8	78.5	15	91	91.3	90.8	74	84	87	6307	6206	E	18.64	CD0005
10	7.5	1770	215TC	TEFC	CEWDM3714T	12	103	29.5	92.1	92.4	91.8	66	79	85	6307	6206	F	21.27	CD0005
10	7.5	1180	256TC	TEFC	CEWDM23932T	15.1	107	44.3	89.4	91.2	91.4	49	61	68	6309	6208	E	23.57	CD0180
15	11	3500	215TC	TEFC	CEWDM3713T	17	150	22.1	91.5	92.2	91.8	77	85	88	6307	6206	E	21.26	CD0180
15	11	3500	254TC	TEFC	CEWDM23994T	16.6	161	22.5	91.5	91.8	91.2	87	92	93	6309	6206	E1	21.94	CD0005
15	11	1765	254TC	TEFC	CEWDM23933T	18	125	45	92.1	93	92.8	71	81	86	6309	6208	F	23.57	CD0005
20	15	3520	256TC	TEFC	CEWDM41906T	22.5	165.7	29.8	92.5	93	92.5	79	86	90	6309	6208	F	23.57	CD0005
20	15	1765	256TC	TEFC	CEWDM23934T	24	171	60	92.9	93.5	93.2	67	79	84	6309	6208	E	23.57	CD0180

NOTE: Volt Code: E = 208-230/460V, 60Hz; E1 = 230/460V, 60Hz, usable at 208V; F = 230/460V, 60 Hz
See page 82 for Layout drawing. See page 93 for Connection Diagrams.
Efficiencies shown are nominal. Data subject to change without notice. Contact Baldor for certified data.

Adjustable Speed Capabilities for Even Greater Energy Efficiency

Super-E® Motors

Super-E motors are Inverter-Ready and meet NEMA MG 1 Part 31.4.4.2. Super-E motors are suitable for use with inverter drives. Motor inverter setup is unique to each specific application. Proper setup and wiring procedures must be closely followed.

Application Considerations

It is necessary that motor-drive applications are commissioned by persons familiar with the operation and setup of adjustable speed drives, applicable electrical codes and any other regulations.

Each drive must be tuned to the motor for the specific application. System operating parameters must be checked, including voltage at motor power leads, to insure that motor/drive setup has been successfully completed.

Applications that are not properly setup can lead to substandard performance and failure of system components. In some installations, shaft grounding and isolated bearings may prevent bearing fluting and are available as an option or through Mod Express.

Reference the chart below for constant torque and variable torque capabilities for each product family. Torque performance depends upon proper drive setup.

Motors 48 body style and smaller are suitable for maximum 230V inverter operation.

Efficiency Savings

Significant energy savings can be achieved when applying Inverter Ready motors such as the Baldor Super-E to centrifugal load applications (fan and centrifugal pump) and running at reduced speed taking advantage of the affinity laws where motor load and corresponding energy consumption is reduced by the cube of the speed.



Family	Enclosure	Frame Size	Constant Torque	Variable Torque	Comments
Super E Motors 230, 460 and 575 Volts (2)					
EM	TEFC	56-210 (1)	20:1	20:1	General Purpose Premium Efficient
		250-320	10:1	20:1	
		360-400	4:1	20:1	
		444-449	2:1	20:1	
EM	ODP	56-210 (1)	10:1	20:1	General Purpose Premium Efficient
		250-320	5:1	20:1	
		360 - 449	2:1	20:1	
ECP/XEX and ECP8/841XL (3)	TEFC	140	20:1	20:1	Severe Duty Premium Efficient
		180-210	10:1	20:1	
		250-400	4:1	20:1	
		444-449	2:1	20:1	
EWDM	TENV,TEFC	56-256 (1)	20:1	20:1	Washdown Duty Premium Efficient
ESS/SSE	TEFC	56-250	2:1	10:1	Stainless Steel Washdown Duty
	TENV	56-140	4:1	10:1	
Standard-E Motors 230/460 and 575V (2) (4)					
M (TEFC)		56-326T frames (1)	4:1	20:1	General Purpose motors
		360T - 449T	2:1	20:1	
M (ODP)		56-326T frames (1)	4:1	20:1	
		360T - 449T	2:1	20:1	
CP/XT		145T frames	4:1	20:1	Severe Duty
		180T-445T frames	2:1	20:1	
		447T-449T frames	2:1	20:1	
WDM		56-215T frames (1)	4:1	20:1	Washdown Duty

NOTES:

(1) Baldor type 35M frames and larger

(2) For greater speed range capabilities, please select an Inverter Duty®, Vector Duty®, V*S Master or RPM AC type motor, or contact your local Baldor Sales Office for a custom motor design.

(3) Stock IEEE-841 motors include Division 2 labeling as standard. These motors will require a nameplate change through Mod Express to add inverter duty markings to the motors.

(4) Standard-E EPAct efficient motors are suitable for use in adjustable speed applications per NEMA MG 1 Part 30.

Dimensions

Steel Band Construction – TEFC Foot Mounted – NEMA 56 - 215T

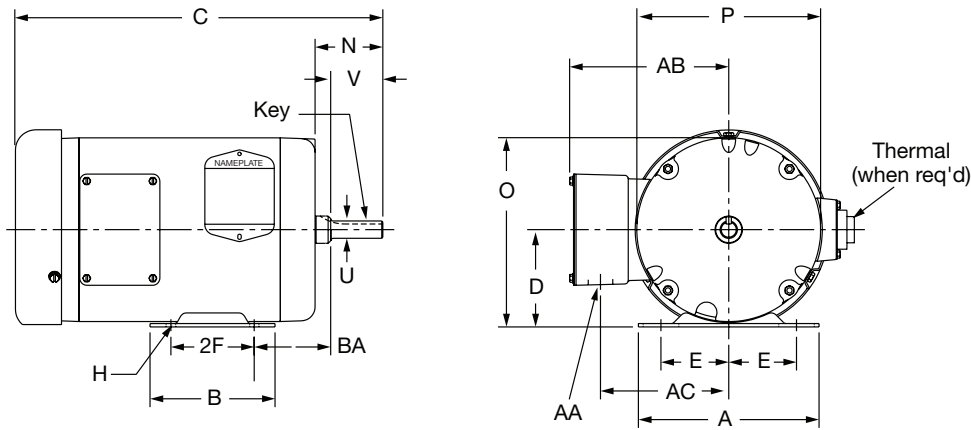

NEMA Frame	A	B	D	E	2F	H	Key	N	O	P	U	V	AA	AB	AC	BA
56	6.50	4.50	3.50	2.44	3.00	0.34 Slot	0.19	2.44	6.81	6.62	0.625	1.88	0.88	5.73	4.62	2.75
143T 145T	6.50	5.94	3.50	2.75	4.00 5.00	0.34	0.19	2.50	6.81	6.62	0.875	2.25	0.88	5.73	4.62	2.25
182T 184T	8.63	6.50	4.50	3.75	4.50 5.50	0.41	0.25	3.56	8.44	7.88	1.125	2.75	1.09	6.87	5.76	2.75
213T 215T	9.50	8.00	5.25	4.25	5.50 7.00	0.41	0.31	3.88	10.03	9.57	1.375	3.38	1.38	8.05	6.79	3.50

NOTE: Drawings shown are for reference only. Please contact Baldor for a detailed dimensional drawing of the specific motor you require.

Steel Band Construction – TEFC & TENV C-Face Foot Mounted & Footless – NEMA 56 - 215TC

TENV Enclosure

TEFC Enclosure

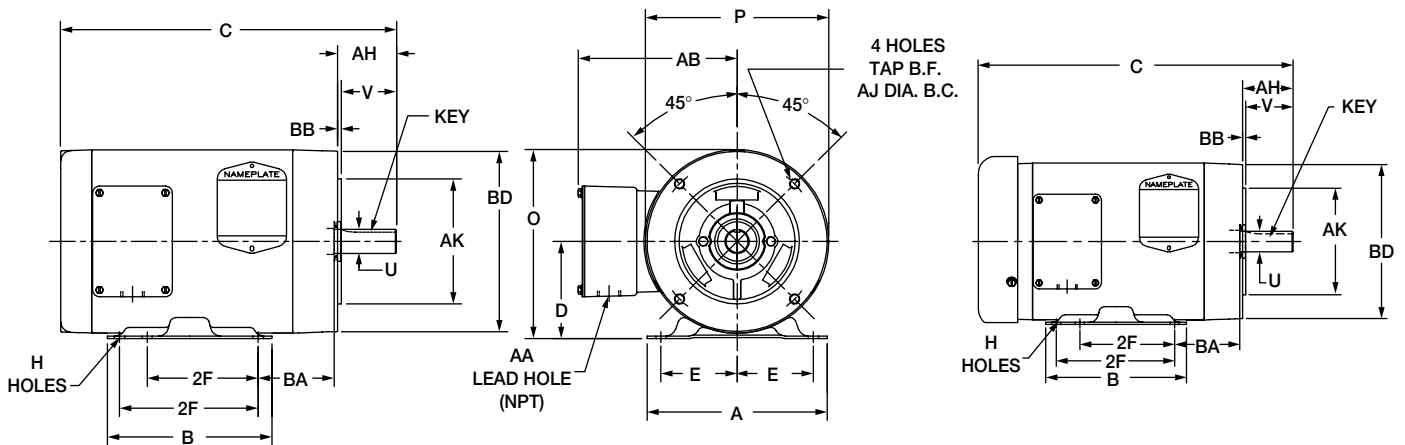

Catalog No. starting with "C" = C-face with base.

Catalog No. starting with "V" = C-face, no base.

NEMA Frame	A	B	D	E	2F	H	O	P	U	V	AA	AB	AH	AJ	BF TAP	AK	BA	BB	BD
56C	6.50	4.50	3.50	2.44	3.00	0.34	6.81	6.62	0.625	1.88	0.88	5.74	2.07	5.88	3/8-16	4.50	2.75	0.13	6.50
143TC 145TC	6.50	5.94	3.50	2.75	4.00 5.00	0.34	6.81	6.62	0.875	2.25	1.09	5.74	2.12	5.88	3/8-17	4.50	2.75	0.13	6.50
182TC 184TC	8.63	6.50	4.50	3.75	4.50 5.50	0.41	8.44	7.88	1.125	2.75	1.09	6.87	2.62	7.25	1/2-13	8.5	3.50	0.25	8.86
213TC 215TC	9.50	8.00	5.25	4.25	5.50 7.00	0.41	10.03	9.56	1.375	3.37	1.38	8.05	3.12	7.25	1/2-13	8.50	4.25	0.25	9.04

NOTE: Drawings shown are for reference only. Please contact Baldor for a detailed dimensional drawing of the specific motor you require.