

# Instructions for The Digitrip RMS 310 3-Pole and 4-Pole Trip Unit Installation and Operation with K-Frame Series C Circuit Breakers

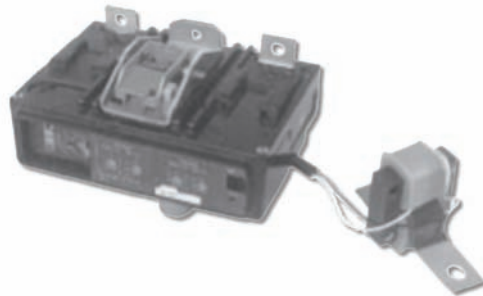

## Contents

Description	Page
1.0 General Information.....	2
2.0 UL Listed Devices.....	3
3.0 Installation.....	3
4.0 Principle of Operation.....	11
5.0 Protection Settings.....	11
6.0 Testing.....	12
7.0 Rating Plug.....	15
8.0 References.....	15

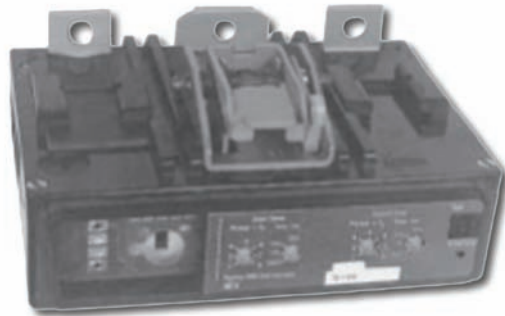

*Powering Business Worldwide*



## **WARNING**

---

**DEATH, SEVERE PERSONAL INJURY, OR SUBSTANTIAL PROPERTY DAMAGE CAN RESULT FROM CONTACT WITH ENERGIZED EQUIPMENT. DO NOT ATTEMPT TO INSTALL OR PERFORM MAINTENANCE ON EQUIPMENT WHILE IT IS ENERGIZED. ALWAYS VERIFY THAT NO VOLTAGE IS PRESENT BEFORE PROCEEDING WITH THE TASK, AND ALWAYS FOLLOW GENERALLY ACCEPTED SAFETY PROCEDURES.**

**EATON IS NOT LIABLE FOR THE MISAPPLICATION OR MISINSTALLATION OF ITS PRODUCTS.**

The User is cautioned to observe all recommendations, warnings, and cautions relating to the safety of personnel and equipment as well as all general and local health and safety laws, codes, and procedures.

The recommendations and information contained herein are based on Eaton experience and judgment, but should not be considered to be all-inclusive or covering every application or circumstance which may arise. If any questions arise, contact Eaton for further information or instructions.

## **1.0 GENERAL INFORMATION**

### **1.1 PROTECTION**

The Digitrip RMS 310, illustrated in Figures **1a**, and **1b**, is an electronic trip unit that incorporates a microprocessor-based custom application specific integrated circuit design for use with Series C K-Frame Molded Case Circuit Breakers.

The Digitrip RMS 310 provides true RMS current sensing for proper correlation with thermal characteristics of conductors and equipment. Interchangeable rating plugs are provided to establish the continuous current rating of each circuit breaker.

The Digitrip RMS 310 Trip Unit is completely self-contained and when the circuit breaker is closed, requires no external control power to operate its protection systems.

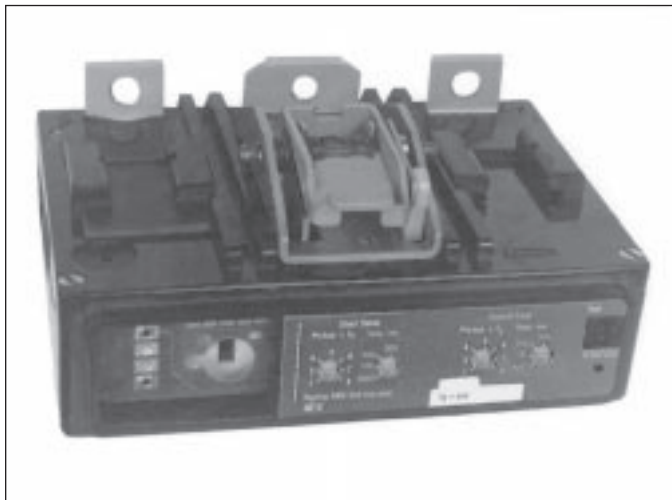

Figure 1a Digitrip RMS 310 Trip Unit for 3-Pole K-Frame Series C Circuit Breaker.

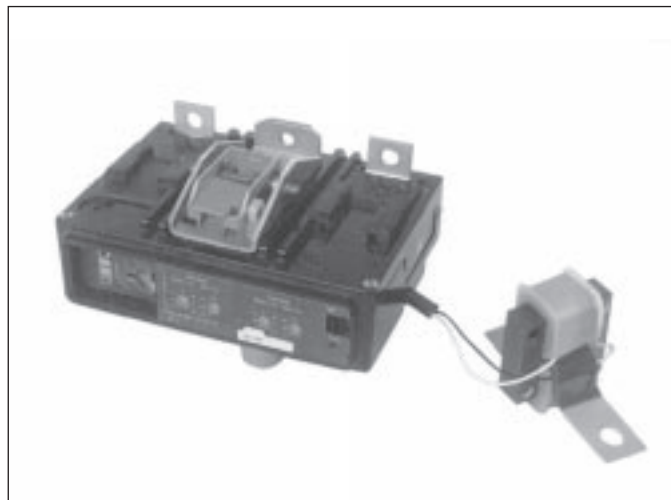

Figure 1b Digitrip RMS 310 Trip Unit for 4-Pole K-Frame Series C Circuit Breaker.

It operates from current signal levels and control power derived through current sensors integrally mounted in the trip unit.

Digitrip RMS 310 Trip Units are suitable for 50/60 Hz AC applications only. For DC applications, a thermal-magnetic trip unit should be used.

The Digitrip RMS 310 Trip Unit is available in 4 different types, (see Table 1-1). Each trip unit contains a fixed long delay time function (adjusted by changing the rating plug), and may be equipped with a maximum of two phase and two ground (time current) adjustments to meet specific application requirements. The types of adjustments available for each model include the following:

Protection	Type
1. Short Delay Pick-up	KESxxxxLS, LSE
2. Short Delay Pick-up/ Short Delay Time	KESxxxxLSI, LSIE
3. Short Delay Pick up/Ground Fault Pick-up/Ground Fault Time	KESxxxxLSG
4. Short Delay Pick-up/Short Delay Time/Ground Fault Pick-up /Ground Fault Time	KESxxxxLSIG

## 2.0 UL LISTED DEVICES

The Digitrip RMS 310 Trip Unit is listed in accordance with Underwriters Laboratories, Inc. Standard UL489, under File E7819 and satisfies the applicable require

ments of the International Electrotechnical Commission (IEC) recommendations for molded case circuit breakers.

## 3.0 INSTALLATION

### 3.1 PREPARATION (ALL TRIP UNITS)

The installation procedure consists of inspecting and installing the trip unit and rating plug. To install the trip unit, perform the following steps.

### NOTICE

**If required, internal accessory installation should be done before the circuit breaker is mounted and connected. Refer to individual accessory instruction leaflets.**

Make sure that the trip unit is suitable for the intended installation by comparing nameplate data with any existing equipment and system requirements. Inspect the trip unit for completeness, and check for damage before installing it in the circuit breaker frame.

### NOTICE

**3-pole KES trip units may be used in 4-pole circuit breakers if the fourth pole is unprotected. A 4-pole**

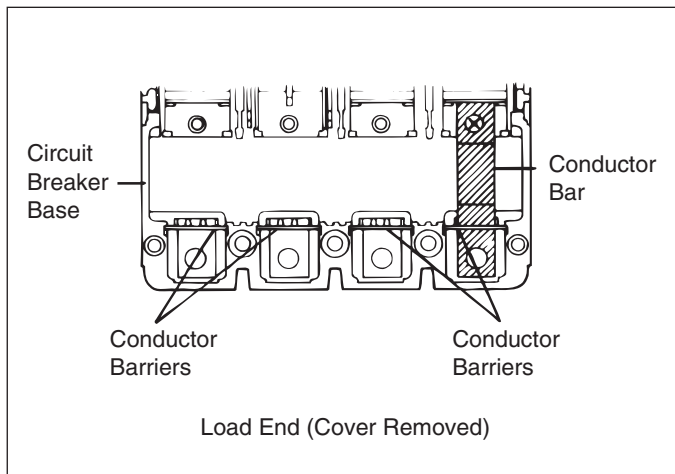

Figure 2 Conductor Barriers (4-pole Circuit Breaker Frame Shown).

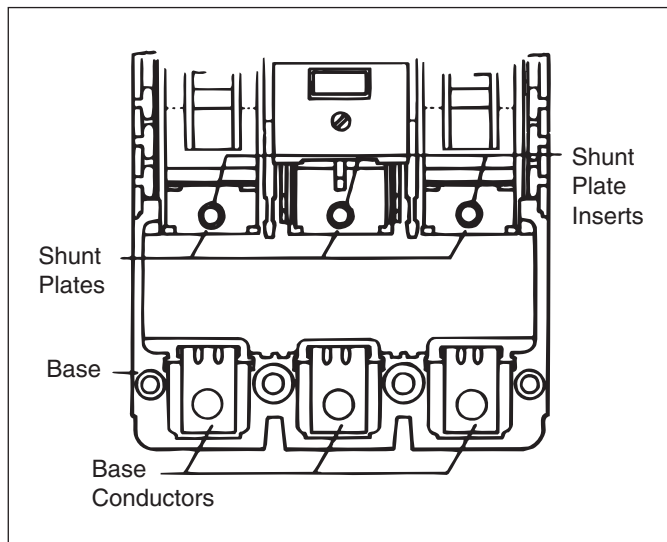

Figure 3 Base Conductors in Position and Shunt Plates Centered Over Base Inserts.

**KES trip unit is required to provide protection of the fourth pole of a 4-pole circuit breaker.**

**Trip Unit center retaining screw is supplied with the trip unit; the remaining retaining screws (2 for a 3-pole trip unit, 3 for a 4-pole trip unit) are supplied with the circuit breaker frame.**

Remove circuit breaker cover screws, and cover.

Remove conductor barriers from base (see Figure 2).

### NOTICE

**If installing a 4-pole trip unit, remove conductor bar from the right-hand (fourth) pole (Figure 2). Discard the conductor but keep the retaining screw.**

Make sure circuit breaker base conductors are positioned in slots in base (see Figure 3).

Remove screws from shunt plate inserts (see Figure 3).

### NOTICE

**The trip unit outer screws may be placed in the trip unit conductor holes at this time. If preferred, a magnetic screwdriver may be used to position the screws when the trip unit is in the base.**

**Make sure shunt plates are centered over shunt plate inserts (see Figure 3).**

To continue installation, proceed to the section applicable to the trip unit being installed:

Trip Unit Type	Section
4-pole Type Trip Unit	3.2
3-pole Ground Fault Trip Unit	3.3
3-pole Non-Ground Fault Trip Unit	3.4

### 3.2 4-POLE TRIP UNIT INSTALLATION

Remove barrier between the third and fourth (right-hand) pole. Find the scored tab (Figure 4) and break away from the barrier to leave a square notch.

Place the trip unit and fourth pole current sensor side by side on a flat surface (see Figure 5).

Remove the CAUTION tag from the current sensor secondary winding leads.

### NOTICE

**Secondary winding connector is not polarized.**

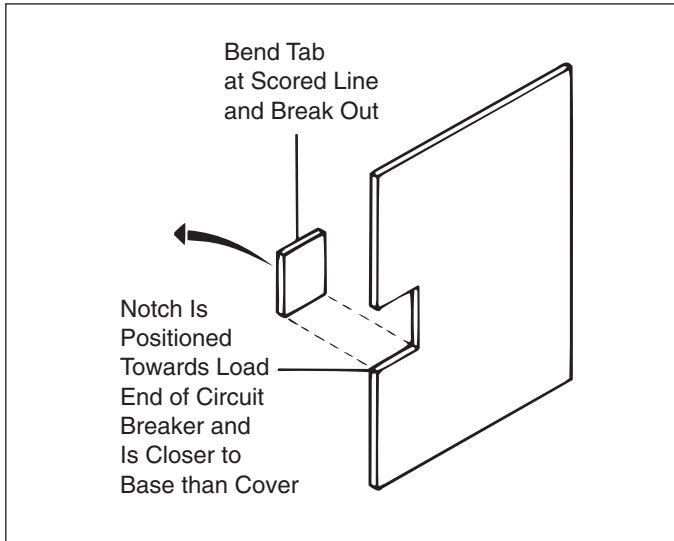

Figure 4 Scored Tab in Barrier.

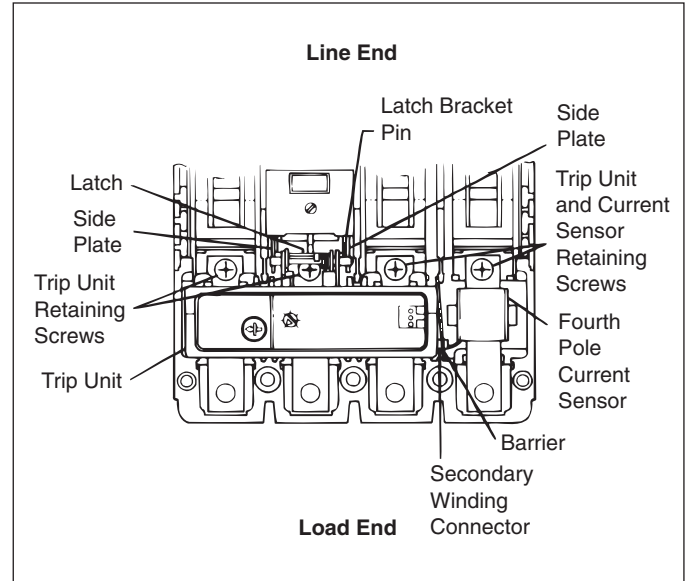

Figure 6 Trip Unit with Rating Plug Installed in Circuit Breaker.

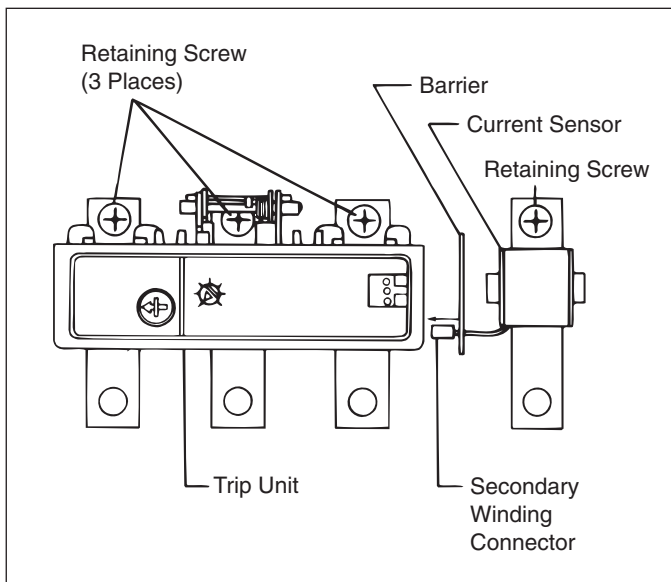

Figure 5 Preliminary Alignment of Trip Unit with Rating Plug and Current Sensor.

Plug the current sensor secondary winding connector into the receptacle in the side of the trip unit. Either polarity is acceptable.

Position the retaining screws in the trip unit and current sensor conductor holes.

Place the barrier with the notch between the trip unit and the current sensor. The notch must fit around the secondary winding connector.

Position trip unit together with the barrier and current sensor in the circuit breaker (see Figure 6). Make sure latch bracket pin is properly seated in slots in side plates. If necessary, latch may be moved toward load end of circuit breaker to seat trip unit.



## CAUTION

**DO NOT EXCEED A TORQUE OF 6 TO 8 LB.-FT (8 TO 10 N.M). EXCESSIVE TORQUING WILL SHEAR SCREWS.**

**FAILURE TO APPLY THE REQUIRED TORQUE MAY LEAD TO EXCESSIVE HEATING AND CAUSE NUISANCE TRIPPING OF THE CIRCUIT BREAKER.**

Screw in and tighten three trip unit retaining screws (center first) and the screw for the current sensor in the fourth pole. Torque to 6 to 8 lb.-ft (8 to 10 N.m) (see Figure 6).

Install accessory(ies), if required, using appropriate instruction leaflet listed in Section 8.2.

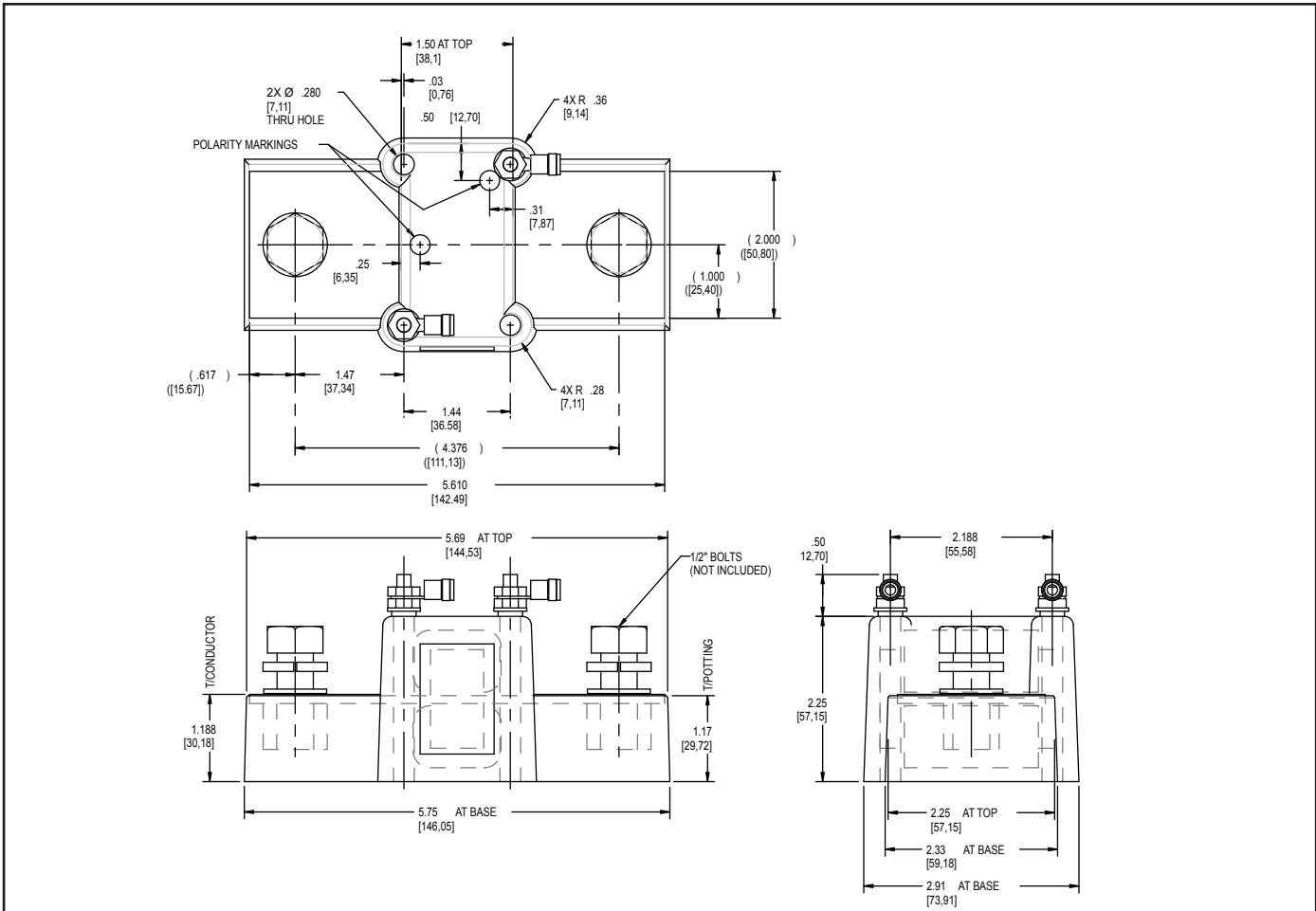

Figure 7 Neutral Current Sensor.

Finish installation of the 4-pole Trip Unit by following the instructions in Section 3.5.

### 3.3 GROUND FAULT TRIP UNIT INSTALLATION

#### 3.3.1 GENERAL

Ground fault trip units are supplied from the factory with one auxiliary switch with pigtail leads (red, blue and black wires) and pigtail lead connections for a neutral current sensor (white and grey wires) and a ground fault alarm relay (yellow and green wires). A neutral current sensor is provided with each trip unit, and the ground fault alarm relay is ordered and shipped separately if required. If the auxiliary switch or the alarm relay are not required, the corresponding leads should be cut off before the trip unit is installed in the breaker.

Digitrip RMS 310 Ground Fault Trip Units detect ground fault currents through Residual Sensing. They are not designed to use source ground or zero sequence

ground fault sensing methods. If the system neutral is grounded, but no phase to neutral loads are used, the neutral current sensor is not necessary. In that case, the white and grey leads on the trip unit should be cut off before installation.

If the system neutral is grounded and phase to neutral loads are used, then the neutral current sensor (see Figure 7) must be used. It should be connected to the breaker according to the diagram in Figure 8. It has the same turns ratio as the phase current sensors in the trip unit.

## NOTICE

**The polarity of the sensor connections is critical. Always observe the polarity markings on the installation drawings. The polarity markings are identified as white dots on the transformers. To insure correct ground fault equipment performance, conduct field**

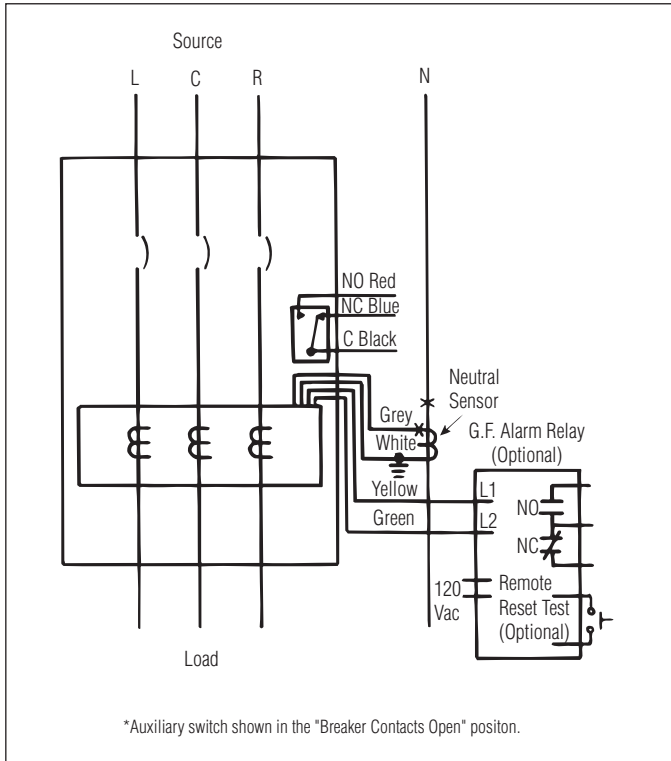

Figure 8 Neutral and Alarm Wiring Diagram.

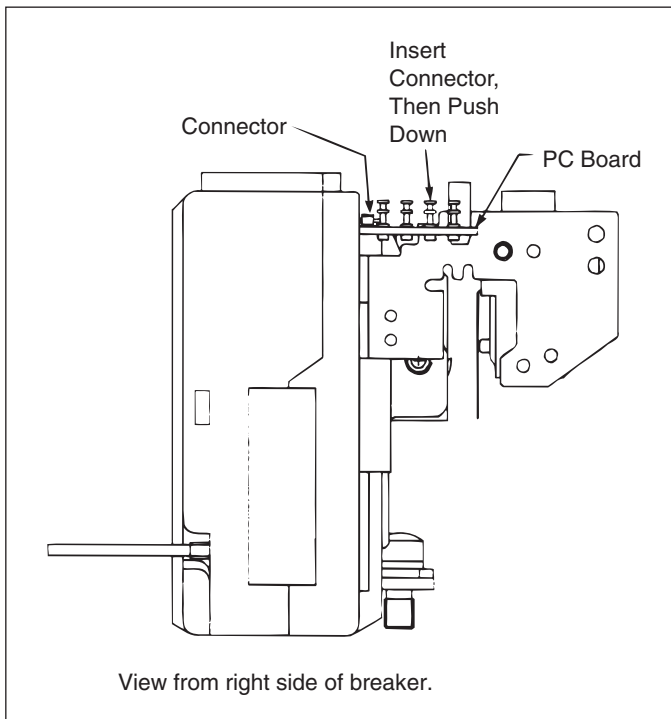

Figure 9 Installing Ground Fault Alarm and Current Sensor Connector PC Board.

tests to comply with National Electric Code requirements under Article 230-95(C). See Section 6.2 for testing instructions.

The optional "Internal Accessories" listed in Section 8.2 are available for installation in the right pole of a Digitrip RMS 310 Ground Fault Trip Unit. These items, if required, must be ordered separately and installed per the instructions in Section 3.3.3.

### 3.3.2 INSTALLATION

Position trip unit in base. Make sure latch bracket pin is properly seated in slots in side plates (see Figure 6). If necessary, move latch toward load end of breaker to seat trip unit.



## CAUTION

**DO NOT EXCEED A TORQUE OF 6 TO 8 LB.-FT (8 TO 10 NM). EXCESSIVE TORQUING WILL SHEAR SCREWS.**

**FAILURE TO APPLY THE REQUIRED TORQUE MAY LEAD TO EXCESSIVE HEATING AND CAUSE NUISANCE TRIPPING OF THE CIRCUIT BREAKER.**

Screw in and tighten three trip unit retaining screws (center first). Torque to 6 to 8 lb.-ft (8 to 10 Nm) (see Figure 6).

To install the ground fault alarm and neutral current sensor connector printed circuit board, an accessory switch must be installed in order to provide a support bracket. If the auxiliary switch supplied with the trip unit will be used, install it in the right pole of the breaker per IL 29C122.

## NOTICE

**See wiring instructions in Section 3.3.3 for special restrictions on accessory wiring for ground fault breakers.**

Next, insert the four-position connector on the printed circuit board into the receptacle in the trip unit and push the board down onto the bracket (see Figure 9).

### 3.3.3 ACCESSORY INSTALLATION WITH GROUND FAULT TRIP UNITS

If an accessory other than the auxiliary switch supplied with the trip unit is to be used, install the accessory by using the appropriate instruction leaflet listed in Section 8.2.

#### NOTICE

See wiring instructions below for special restrictions on accessory wiring for ground fault breakers. Then install the ground fault alarm and neutral current sensor connector printed circuit board as described above.



#### CAUTION

**LEADS COULD BE DAMAGED IF IN CONTACT WITH MOVING PARTS. ACCESSORY WIRES SHOULD BE FORMED AND ROUTED TO CLEAR ALL MOVING PARTS.**

When the appropriate accessory and the connector board are installed there are up to three sets of leads to be routed:

1. Two leads (white and grey) for the neutral current sensor,
2. Two leads (yellow and green) for the ground fault alarm relay, and
3. Three leads (red, blue and black) for the accessory switch.

If all three sets of connections are required, it is not possible to have leads exiting breaker on the opposite side. For rear existing leads (preferred), thread the leads through the wiring troughs in the side of the circuit breaker case. For side existing leads, use the slots in the side of the case. Use the trough or slot farthest from the trip unit for the auxiliary switch leads (red, blue and black), the center trough or slot for the neutral current sensor leads (white and grey), and the trough or slot closest to the trip unit for the alarm leads (yellow and green).

If only one or two sets of leads are required, they can be routed to the side or rear as above, or one set can be fed to the opposite side through the rear wiring trough. This set of leads should first be threaded through the center wiring trough in the side of the case, then through the rear wiring trough. Any other leads to be brought out should then be threaded through the wiring trough closest to the trip unit.

Finish installation of the ground fault trip unit by following the instructions in Section 3.5.

### 3.4 3-POLE (NON-GROUND FAULT) TRIP UNIT INSTALLATION

Position trip unit in base. Make sure latch bracket pin is properly seated in slots in side plates (see Figure 6). If necessary, move latch toward load end of circuit breaker to seat trip unit.



#### CAUTION

**DO NOT EXCEED A TORQUE OF 6 TO 8 LB.-FT (8 TO 10 NM). EXCESSIVE TORQUING WILL SHEAR SCREWS.**

**FAILURE TO APPLY THE REQUIRED TORQUE MAY LEAD TO EXCESSIVE HEATING AND CAUSE NUISANCE TRIPPING OF THE CIRCUIT BREAKER.**

Screw in and tighten three trip unit retaining screws (center first). Torque to 6 to 8 lb.-ft (8 to 10 Nm) (see Figure 6).

Install accessory(ies), if required, using the appropriate instruction leaflet listed in Section 8.2.

### 3.5 FINAL INSTALLATION INSTRUCTIONS (ALL TRIP UNITS)

Install conductor barriers in slots in base (see Figure 2).



#### CAUTION

**DAMAGED THREADS CAN RESULT IN IMPROPER CIRCUIT BREAKER COVER RETENTION. WHEN REMOVING OR REINSTALLING, THREAD FORMING SCREWS TRY TO RE-FORM THE THREADS IN THE CIRCUIT BREAKER BASE. CARE SHOULD BE TAKEN EVERY TIME A THREAD FORMING SCREW IS USED TO ENSURE THE SCREW STARTS IN THE ORIGINAL THREADS.**

#### NOTICE

**When the trip unit is installed in a new circuit breaker frame, the remaining cover mounting hardware is supplied in a plastic bag with the frame.**

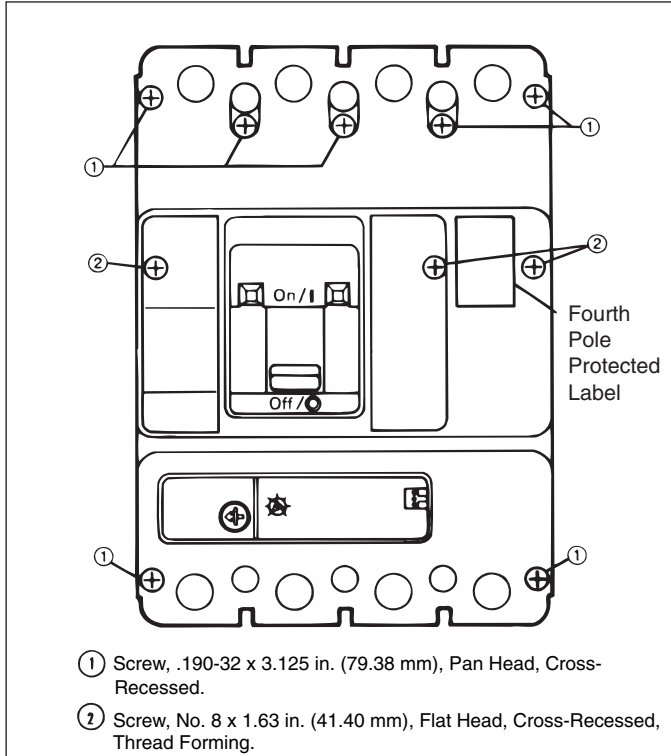

Figure 10 Cover Screw Installation Positions.

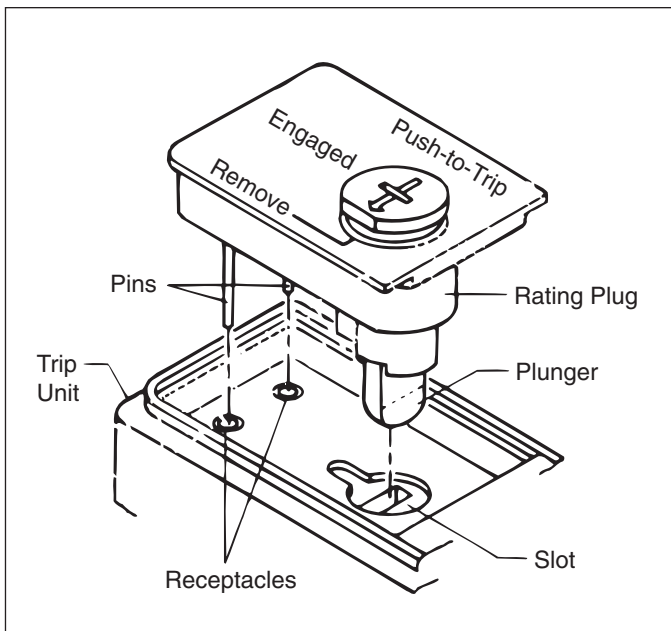

Figure 11 Installing Rating Plug.

Install circuit breaker cover and pan-head screws followed by thread forming screws as shown in Figure 10.

An additional label is included with each four pole trip unit. Position the label marked **Fourth Pole Protected** in the location shown in Figure 10.



## CAUTION

**THE RATING PLUG MECHANICALLY INTERLOCKS WITH THE TRIP UNIT. IF THE RATING PLUG IS NOT CORRECTLY INSTALLED, THE CIRCUIT BREAKER CANNOT BE RESET OR PLACED IN THE ON POSITION.**

## NOTICE

**Before attempting to install the rating plug, the arrow in the Push-to-Trip button portion of the plug must be pointing toward the REMOVE position. This can be done with a small screwdriver.**

Install rating plug. Position the rating plug as shown in Figure 11. Insert the rating plug in the trip unit. The two pins and plunger must align correctly with the matching receptacles and slot in the trip unit. After the rating plug is pressed into position, depress the Push-to-Trip button with a small screwdriver and turn it clockwise one quarter of a turn until the arrow points to ENGAGED. If an adjustable rating plug is used, four continuous current settings are possible. Set the switch marked A, B, C, D to the current rating desired (see Figure 13).

Reset circuit breaker by moving handle to the reset position. Move handle to the ON position. Circuit breaker handle should remain at the ON position.

Press Push-to-Trip button (in rating plug) to check manual tripping of the circuit breaker.

The status light monitors the operation of the trip unit as explained in Section 4.0.

## NOTICE

**The reverse procedure is used to remove the rating plug. Turn the Push-to-Trip button to the remove position. This action will cause the circuit breaker to trip. Then grasp the lip of the Push-to-Trip button and gently pull. A small screwdriver placed under the left edge of the rating plug will assist in removal.**

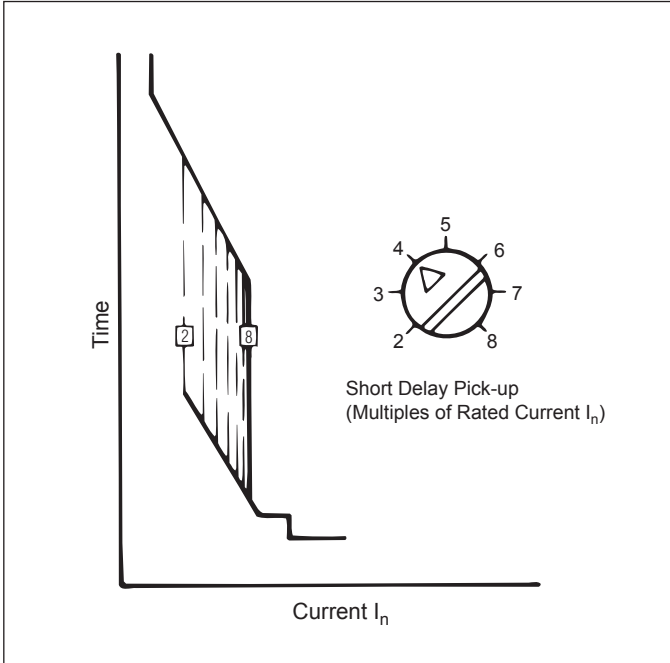

Figure 12-1 Short Delay Trip Current Adjustment and Curve Details.

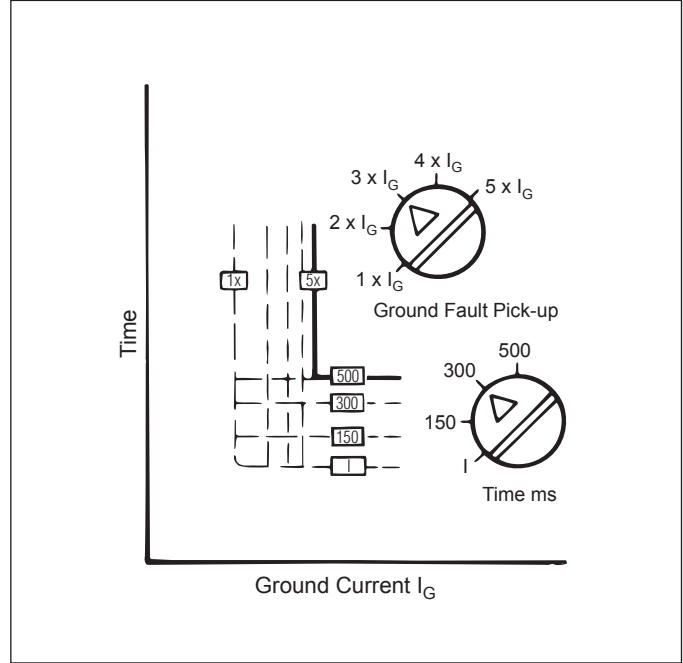

Figure 12-3 Ground Fault Trip Current, and Ground Fault Trip Time Adjustments and Curve Details.

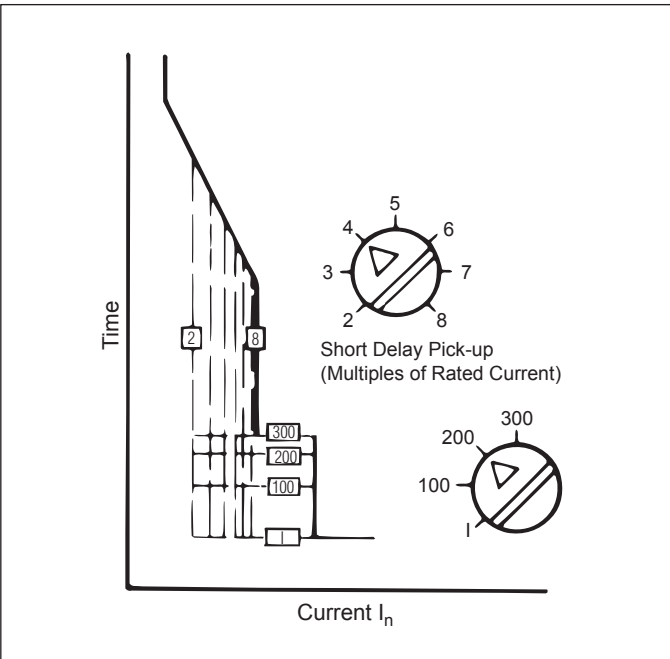

Figure 12-2 Short Delay Trip Current and Short Delay Trip Time Adjustment and Curve Details.

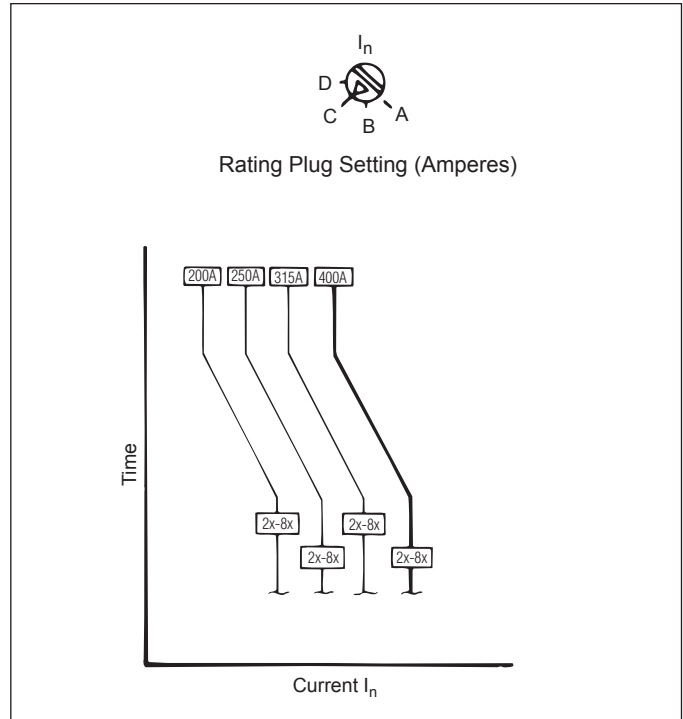

Figure 13 Optional Adjustable Ampere Setting Rating Plug Used in Digitrip RMS 310 Trip Unit.

## 4.0 PRINCIPLE OF OPERATION

In open air at 40°C (104°F), an K Frame circuit breaker with a Digitrip RMS 310 Trip Unit installed will carry continuously up to 400 amperes without exceeding a 50°C (122°F) rise at the terminals. The calibration of the trip unit is insensitive to ambient temperatures over a range of -20 to +55°C (-4 to 131°F). However, the trip unit contains thermal temperature protective circuitry that initiates a trip operation for self-protection if the internal ambient temperature at the printed circuit board (PCB) reaches approximately 90°C (194°F). This may occur for open air temperatures above 40°C with circuit breaker currents near full load.

For ambient conditions above 40°C and where the maximum ampere rating plug has been installed, derating of the circuit breaker frame should be considered to avoid exceeding a safe terminal temperature operating range. Consult Eaton for recommendations.

### 4.1 GENERAL

The Digitrip RMS 310 Trip Unit provides a tripping signal to the flux transfer shunt trip when current and time delay settings are exceeded. This is accomplished by employing the Eaton custom designed integrated circuit Sure™ chip, which includes a microcomputer to perform its numeric and logic functions.

In the Digitrip RMS 310 Trip Unit, all required sensing and tripping power to operate its **protection function** is derived from the current sensors in the circuit breaker. The secondary currents from these sensors provide the correct input information for the protection functions, as well as tripping power, when ever the circuit breaker is carrying current. These current signals develop voltages across the appropriate calibrating resistors.

The microcomputer, in cyclic fashion, repeatedly scans the voltage values across each calibrating resistor and enters these values into memory. These data are used to calculate true RMS current values, which are then repeatedly compared with the protection function settings and other operating data stored in the memory. The software program then determines whether to initiate protection functions, including tripping the breaker through the flux transfer shunt trip device in the circuit breaker.

A green status light indicates the operational status of the trip unit. If the load current through the circuit breaker exceeds approximately 20% of the maximum current rating of the trip unit, the status light will blink on and off once each second. A blinking status light is an indication of a properly functioning trip unit. If the status light is not blinking, the current through the breaker may be less than 20% of the maximum current rating of the trip unit.

If the current exceeds 20% and the status light is not blinking, use the STK2 test kit to investigate (see section 6.1). IF THE STATUS LIGHT IS ON STEADY, IT INDICATES A TRIP IS PENDING.



## CAUTION

**LACK OF ILLUMINATION OF THE STATUS LED DOES NOT INDICATE THE TERMINALS OF THE BREAKER ARE DEENERGIZED.**

### 4.2 OVERLOAD TRIP

In accordance with standards requirements, the trip unit initiates a trip of the circuit breaker within two hours for an overload of 135 %, and will trip in less time for higher overload currents.

A “Thermal Memory” effect prevents the breaker from being re-energized immediately after an overload trip. A “cooling off” period of up to 5 minutes is required, which allows time for cabling to cool off.

### 4.3 SHORT DELAY/INSTANTANEOUS TRIP

For short circuit conditions that exceed the short delay pick-up settings, the trip unit initiates a trip after a delay prescribed by the  $I^2t$  ramp function for trip units with catalog number suffixes LS, LSE, LSP, and LSG. A flat response time delay action is provided by trip units with catalog number suffixes LSI, LSIE, and LSIQ unless the instantaneous (I) setting is selected.

### 4.4 GROUND FAULT PROTECTION

When selected, ground fault pick up and time delay settings shown in Table 1-2 allow selective ground fault coordination with other circuit protection devices.

## 5.0 PROTECTION SETTINGS

### 5.1 GENERAL

Prior to placing any circuit breaker in operation, each trip unit protection setting must be set to the values specified by the engineer responsible for the installation. The available settings along with the effect of changing the settings are illustrated in Figures 12-1 to 12-3.

The installed rating plug establishes the maximum continuous current rating ( $I_n$ ) of the circuit breaker. Short delay current settings are defined in multiples of  $I_n$ .

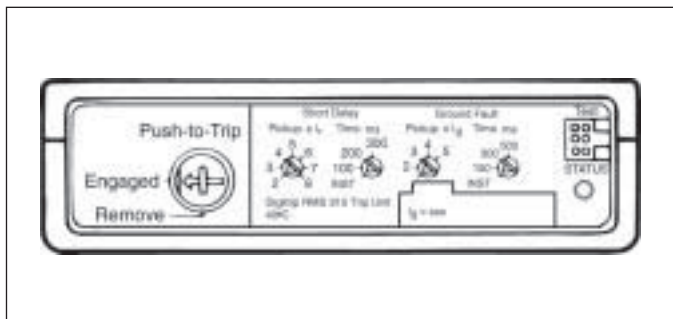

Figure 14 Adjustment Switches and Test Points.

One to four time and pick-up adjustment settings are available depending on the particular trip unit purchased. A rotary switch is provided for each setting. The rotary switch is adjusted using a small flatblade screwdriver (Figure 14).

## 5.2 SHORT DELAY PICK-UP SETTING

Seven settings are available that range from 2 to 8 ( $I_n$ ) as shown in Figure 12-1. This feature is included on all Digitrip RMS 310 Trip Units.

## 5.3 SHORT DELAY TIME SETTINGS

For catalog number KESxxxxLS, -LSG, -LSP and -LSE, the short time delay is an  $I^2t$  ramp configuration with the actual time delay a function of the trip current involved.

For catalog numbers KESxxxxLSI, -LSIG, and LSIE, the short time delay is a flat response. Four settings (1, .1, .2, .3 second) are available (see Figure 12-2). The "1" setting gives a trip response with no intentional delay (Instantaneous).

## 5.4 INSTANTANEOUS PICKUP SETTING

For catalog numbers KESxxxxLSI, -LSIG, and LSIE, Instantaneous Pick-up is achieved by setting Short Delay Time to "1" (Instantaneous). Short Delay Pickup (see paragraph 5.2) then becomes Instantaneous Pickup.

## 5.5 GROUND FAULT PICK-UP SETTING

Five settings ranging from 1 through 5 ( $xI_G$ ) are available (see Figure 12-3) and correspond to the fixed ampere values listed on the trip unit nameplate and in Table 1-2.

## NOTICE

**These ampere values are always the same no matter what rating plug is installed in the circuit breaker.**  
Available on Catalog Nos. KES3xxxLSG and LSIG.

## 5.6 GROUND FAULT TIME SETTINGS

The ground fault time delay is a flat response with four settings (1, .15, .3, .5 second) available (Figure 12-3). The 1 setting gives a trip response with no intentional delay (Instantaneous). This option is available on Catalog Nos. KES3xxxLSG and -LSIG.

## 6.0 TESTING

### 6.1 FUNCTIONAL FIELD TESTING

A test receptacle is built into each trip unit to allow use of the STK2 Test Kit. The Test Kit performs a test of the Long Delay, Short Delay and Ground Fault functions.

### 6.2 PERFORMANCE TESTING FOR GROUND FAULT TRIP UNITS

#### 6.2.1 CODE REQUIREMENTS

The National Electrical Code under Article 230-95-C requires that any ground-fault protection system be performance tested when first installed. The test shall be conducted in accordance with approved instructions provided with the equipment. A written record of this test shall be made and shall be available to the authority having inspection jurisdiction.

#### 6.2.2 STANDARDS REQUIREMENTS

As a follow-up to the basic performance requirements stipulated by the N.E.C. as stated above, UL Standard No. 1053 requires that certain minimum instructions must accompany each ground fault protection system. These following statements plus a copy of the test record form illustrated in Figure 17 are shipped with each Digitrip RMS 310 Trip Unit.

#### 6.2.3 GENERAL TEST INSTRUCTIONS

The interconnected system shall be evaluated in accordance with the equipment assembler's detailed instructions by qualified personnel.

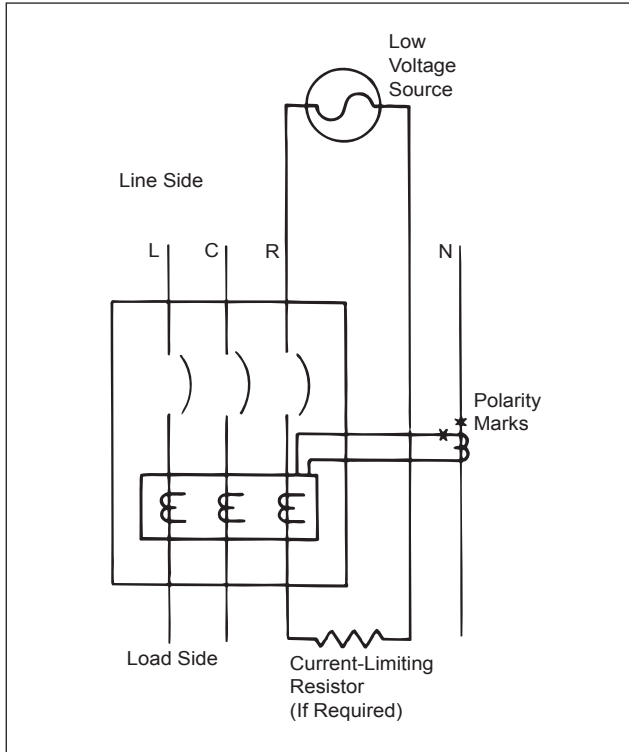

Figure 15-1 Connections for a Trip Test on Ground Fault.

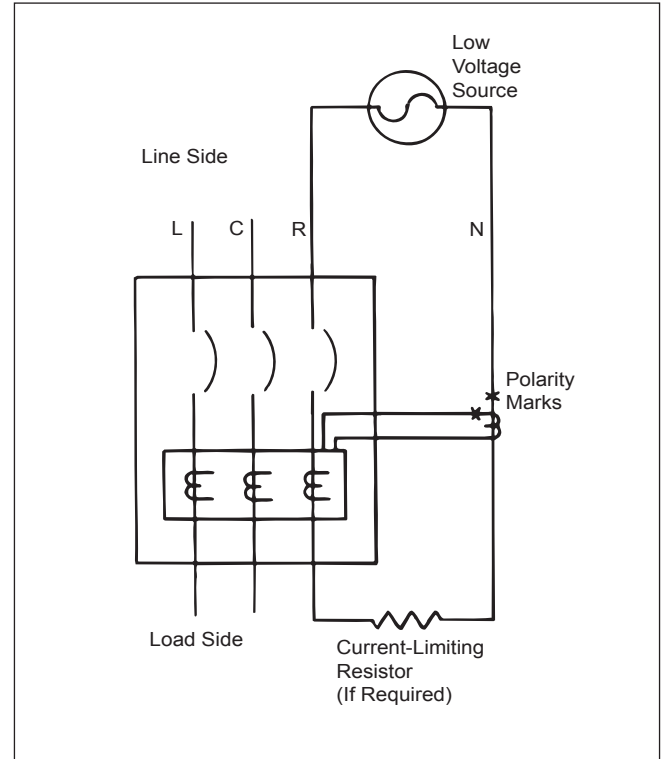

Figure 15-2 Connections for a No-Trip Test on Ground Fault for a Four-Wire System.

The polarity of the neutral sensor connections (if used) must agree with equipment assembler's detailed instructions to avoid improper operations following apparently correct simulated test operations. Where a question exists, consult the specifying engineer and/or equipment assembler. The grounding points of the system shall be verified to determine that ground paths do not exist that would bypass the sensors. The use of high-voltage testers and resistance bridges may be used.



## WARNING

**THERE IS A HAZARD OF ELECTRICAL SHOCK OR BURN WHENEVER WORKING IN OR AROUND ELECTRICAL EQUIPMENT. ALWAYS TURN OFF POWER SUPPLYING BREAKER BEFORE CONDUCTING TESTS.**

## NOTICE

**Since the Digitrip RMS 310 Trip Units derive their operating power from the phase currents, and not from the neutral current, passing current through the neutral sensor will not properly test the ground fault feature.**

When testing the lowest Ground Fault Pick Up (GFPU) setting,  $1 \times I_e$ , the indicated connections in Figure 15-4a must be used. For single phase currents that are 20% of the sensor current rating, the trip unit will not power up. Therefore, Ground Fault testing cannot be performed in the usual manner.

The connections displayed in Figure 15-4a and 15-4b effectively multiply the power up current by a factor of 3. With this setup, two of the three currents will cancel and the third current should cause the breaker to trip at the lowest setting.

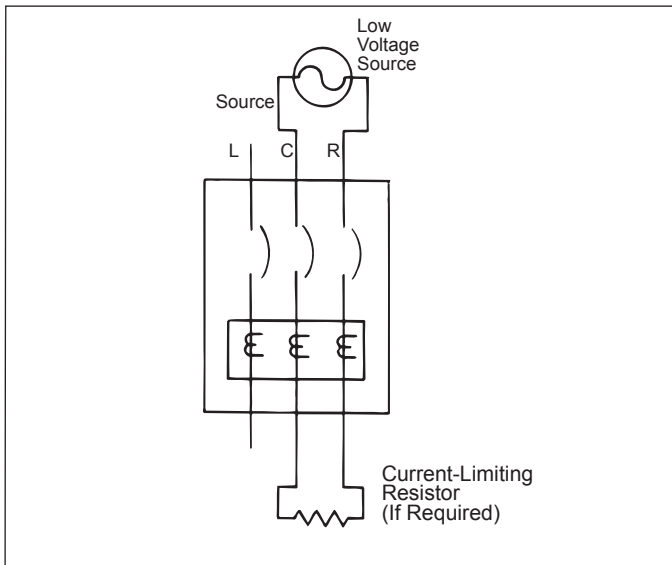

Figure 15-3 Connections for Ground Fault No-Trip Test with a Three-Wire System.

For all other GFPU settings, using a low voltage (0-24 volt), high current, AC source, apply a test current of 125% of the Digitrip RMS 310 Ground Fault Trip Unit pick-up setting through one phase of the circuit breaker, as shown in Figure 15-1. This should cause the breaker to trip in less than 1 second, and if an alarm indicator is supplied, it should operate. Reset the breaker and the alarm indicator. Repeat the test on the other two phases.

If the system is a 4-wire system with a neutral current sensor, apply the same current as described above through one phase of the breaker, returning through the neutral sensor, as shown in Figure 15-2. The breaker should not trip, and the alarm indicator, if supplied, should not operate. Repeat the test on the other two phases.

If the system is a 3-wire system with no neutral current sensor, apply the same current as described above through any two phases of the breaker, with the connections exactly as shown in Figure 15-3. The breaker should not trip, and the alarm indicator, if supplied, should not operate. Repeat the test using the other two combinations of breaker phases.

The results of the test are to be recorded on the test form provided with the equipment.

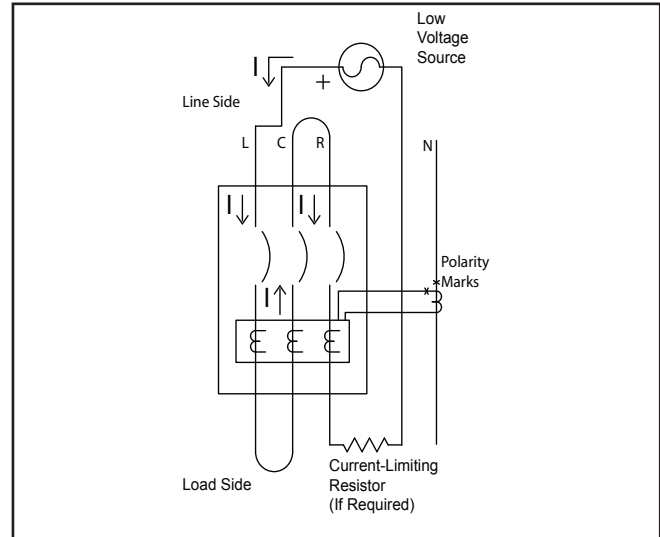

Figure 15-4a Connections for a Trip Test on Ground Fault when testing the lowest of pickup setting.

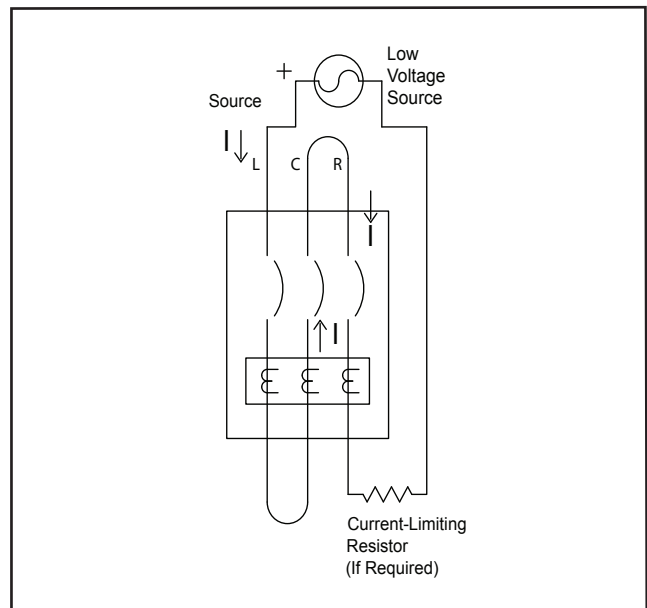

Figure 15-4b Connections for Ground Fault Trip Test with a Three-Wire System when testing the lowest GF pickup setting.



**CAUTION**

**FIELD TESTING SHOULD BE USED FOR FUNCTIONAL TESTING AND NOT FIELD CALIBRATION OF THE DIGITRIP RMS 310 GROUND FAULT TRIP UNIT.**

**ANY TEMPORARY CONNECTION MADE FOR THE PURPOSE OF CONDUCTING TESTS SHOULD BE RESTORED TO PROPER OPERATING CONDITIONS BEFORE RETURNING THE BREAKER TO SERVICE.**

**GROUND FAULT TEST RECORD FORM**

Ground Fault Test Record Should Be Retained by Those in Charge of the Building's Electrical Installation in Order to Be Available to the Authority having Jurisdiction.

Test Date	Circuit Breaker Number	Results	Tested By:

**7.0 RATING PLUG**

The rating plug, as illustrated in Figure 16, is used to establish the continuous ampere rating of the related circuit breaker.

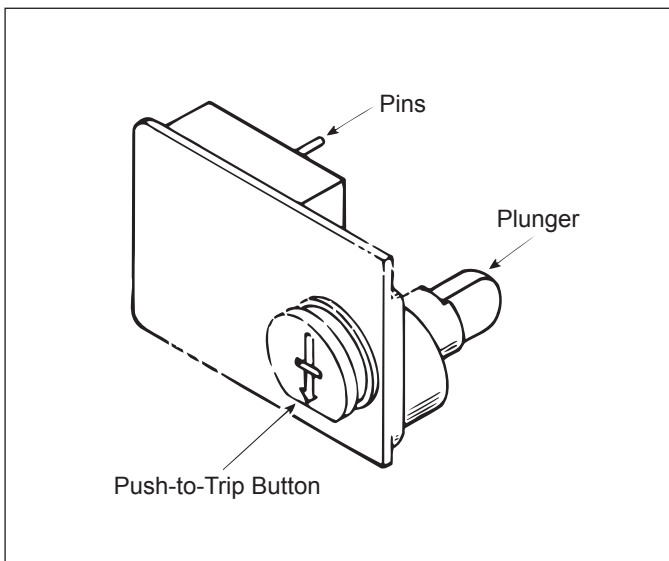

Figure 16 Typical Rating Plug.

For adjustable rating plugs (Table 1-2), the primary current carrying conductors used with the breaker must be sized to correspond with the maximum setting of the rating plug, in accordance with National Electrical Code requirements.

The Long Delay protection function of the trip unit is set at the rating plug value ( $I_n$ ). The Short Delay and Instantaneous protection functions are set as a multiple of  $I_n$ . The Ground Fault protection function is independent of  $I_n$ .

Different rating plugs are available (Table 1-2) to match the desired current rating and type of circuit breaker into which the trip unit is to be installed.

Complete catalog descriptions of all available rating plugs are given in the applicable circuit breaker supplementary instruction leaflets (see Section 8.0).

**8.0 REFERENCES**

**8.1 SERIES C K-FRAME MOLDED CASE CIRCUIT BREAKERS**

29C104 Frame Instruction Leaflet  
AD 29-167K Typical Time-Current Characteristic Curves for K-Frame Breakers

**8.2 INTERNAL ACCESSORIES**

The following types of internal accessories, which mount on the trip unit, are available for use. The number of the instruction leaflet covering the installation of each accessory is shown.

- Alarm (Signal)/Lockout (ASL) Switch .....I.L. 29C182
- Auxiliary Switch .....I.L. 29C122
- Shunt Trip .....I.L. 29C144
- Low Energy Shunt Trip .....I.L. 29C145
- Undervoltage Release Mechanism (Handle Reset) .....I.L. 29C166

**8.3 ATTACHMENT AND GROUND FAULT ALARM UNIT CATALOG NUMBERS**

Catalog Number	Additional Components
A1X3PK	Auxiliary Switch and Pigtail Leads
A1X3RTK	Auxiliary Switch and Terminal Block
AAL3RPK	Alarm Signal/(Lockout) Switch and Pigtail Leads
AAL3RTK	Alarm Signal/(Lockout) Switch and Terminal Block
GFAU	Ground Fault Alarm Unit

Table 1-1 Digitrip RMS 310 Trip Unit Type Catalog Numbers.

Trip Unit Functions		3 POLE				4 POLE			
		KES3125LS KES3250LS KES3400LS	KES3125LSI KES3250LSI KES3400LSI	KES3125LSG KES3250LSG KES3400LSG	KES3125LSIG KES3250LSIG KES3400LSIG	KES4400LS KES4250LS	KES4400LSI KES4250LSI	KES4400LSE KES4250LSE	KES4400LSIE KES4250LSIE
Long Delay	Fixed Ampere Rating <sup>①</sup> with Fixed Long Delay	•	•	•	•	•	•	•	•
	Adjustable Ampere Setting with Fixed Long Delay <sup>②</sup>	•	•	•	•	•	•	•	•
Short Delay	Adjustable Short Delay Pick-up with Short Delay Time I <sup>2</sup> t Ramp	•		•		•		•	
	Adjustable Short Delay Time <sup>③</sup> with Adjustable Short Delay Pick-up, or		•		•		•		•
	Adjustable Instantaneous Pick-up <sup>③</sup>		•		•		•		•
Instant.	Fixed Instantaneous (Override) <sup>④</sup>	•	•	•	•	•	•	•	•
Ground Fault	Adjustable Ground Fault Pick-up with Adjustable Ground Fault Time			•	•				
Fourth Pole Protection	100% Rating for Fourth Pole					•	•		
	50% Rating for Fourth Pole							•	•

① Fixed rating plugs available, see Table 1-2.  
 ② Optional four-setting adjustable rating plugs available, see Table 1-2.  
 ③ Using trip unit with adjustable short delay time (LSI, LSIG, and LSIE), instantaneous pick-up is achieved when the lowest time delay setting (I) is selected.  
 ④ A non-adjustable override setting is set at the frame withstand rating.

Table 1-2 Digitrip RMS 310 Trip Unit Trip Function and Rating Settings.

Trip Function	Rating/Setting Description	
Ampere Rating Fixed at 100%	Fixed rating plugs available:	
	Trip Unit Ampere Rating	Fixed Rating Plugs
	125A 250A 400A	63A <sup>①</sup> , 70A, 90A, 100A, 110A, 125A (I <sub>n</sub> ) 125A, 150A, 160A <sup>①</sup> , 175A, 200A, 225A, 250A (I <sub>n</sub> ) 200A, 225A, 250A, 300A, 315A <sup>①</sup> , 350A, 400A (I <sub>n</sub> )
Adjustable Long Delay Pick-up	Adjustable rating plugs available:	
	Trip Unit Ampere Rating	Adjustable Rating Plugs
	125A  250A  400A	70A-90A-100A-125A (I <sub>n</sub> ) 63A-80A-100A-125A (I <sub>n</sub> ) <sup>①</sup> 125A-150A-200A-250A (I <sub>n</sub> ) 125A-160A-225A-250A (I <sub>n</sub> ) <sup>①</sup> 200A-250A-300A-400A (I <sub>n</sub> ) 200A-250A-315A-400A (I <sub>n</sub> ) <sup>①</sup> 250A-300A-350A-400A (I <sub>n</sub> )
Short Delay Pick-up (Adjustable)	In multiples of installed rating plug amperes (I <sub>n</sub> ) with marks at 2-3-4-5-6-7-8x	
Short Delay Time (Fixed)	I <sup>2</sup> t ramp configuration	
Short Delay Time (Adjustable)	Flat response with time delay settings at 100 ms, 200 ms, and 300 ms	
Instantaneous Pick-up <sup>②</sup>	In multiples of installed rating plug amperes (I <sub>n</sub> ) with marks at 2-3-4-5-6-7-8x	
Ground Fault Pick-up (Adjustable)	Trip Unit Ampere Rating	Settings
	400A 250A 125A	80A, 160A, 240A, 320A, and 400A 50A, 100A, 150A, 200A, and 250A 25A, 50A, 75A, 100A, and 125A
Ground Fault Time Delay	Settings at instantaneous (I), 150ms, 300ms, and 500ms	

① Not UL Listed.

② Occurs with short delay time adjustment set at I.

**Notes:**

**Notes:**

The instructions for installation, testing, maintenance, or repair herein are provided for the use of the product in general commercial applications and may not be appropriate for use in nuclear applications. Additional instructions may be available upon specific request to replace, amend, or supplement these instructions to qualify them for use with the product in safety-related applications in a nuclear facility.

This Instruction Booklet is published solely for information purposes and should not be considered all-inclusive. If further information is required, you should consult an authorized Eaton sales representative.

The sale of the product shown in this literature is subject to the terms and conditions outlined in appropriate Eaton selling policies or other contractual agreement between the parties. This literature is not intended to and does not enlarge or add to any such contract. The sole source governing the rights and remedies of any purchaser of this equipment is the contract between the purchaser and Eaton.

**NO WARRANTIES, EXPRESSED OR IMPLIED, INCLUDING WARRANTIES OF FITNESS FOR A PARTICULAR PURPOSE OR MERCHANTABILITY, OR WARRANTIES ARISING FROM COURSE OF DEALING OR USAGE OF TRADE, ARE MADE REGARDING THE INFORMATION, RECOMMENDATIONS, AND DESCRIPTIONS CONTAINED HEREIN.**

In no event will Eaton be responsible to the purchaser or user in contract, in tort (including negligence), strict liability or otherwise for any special, indirect, incidental or consequential damage or loss whatsoever, including but not limited to damage or loss of use of equipment, plant or power system, cost of capital, loss of power, additional expenses in the use of existing power facilities, or claims against the purchaser or user by its customers resulting from the use of the information, recommendations and description contained herein.

**Eaton Corporation**  
Electrical Sector  
1111 Superior Ave.  
Cleveland, OH 44114  
United States  
877-ETN-CARE (877-386-2273)  
Eaton.com

© 2011 Eaton Corporation  
All Rights Reserved  
Printed in USA  
Publication No. IL29C614F / TBG000772  
Part No. 6612C36H06  
December 2011