

Power Xpert Branch Circuit Monitor (PXBCM)

Install Guide

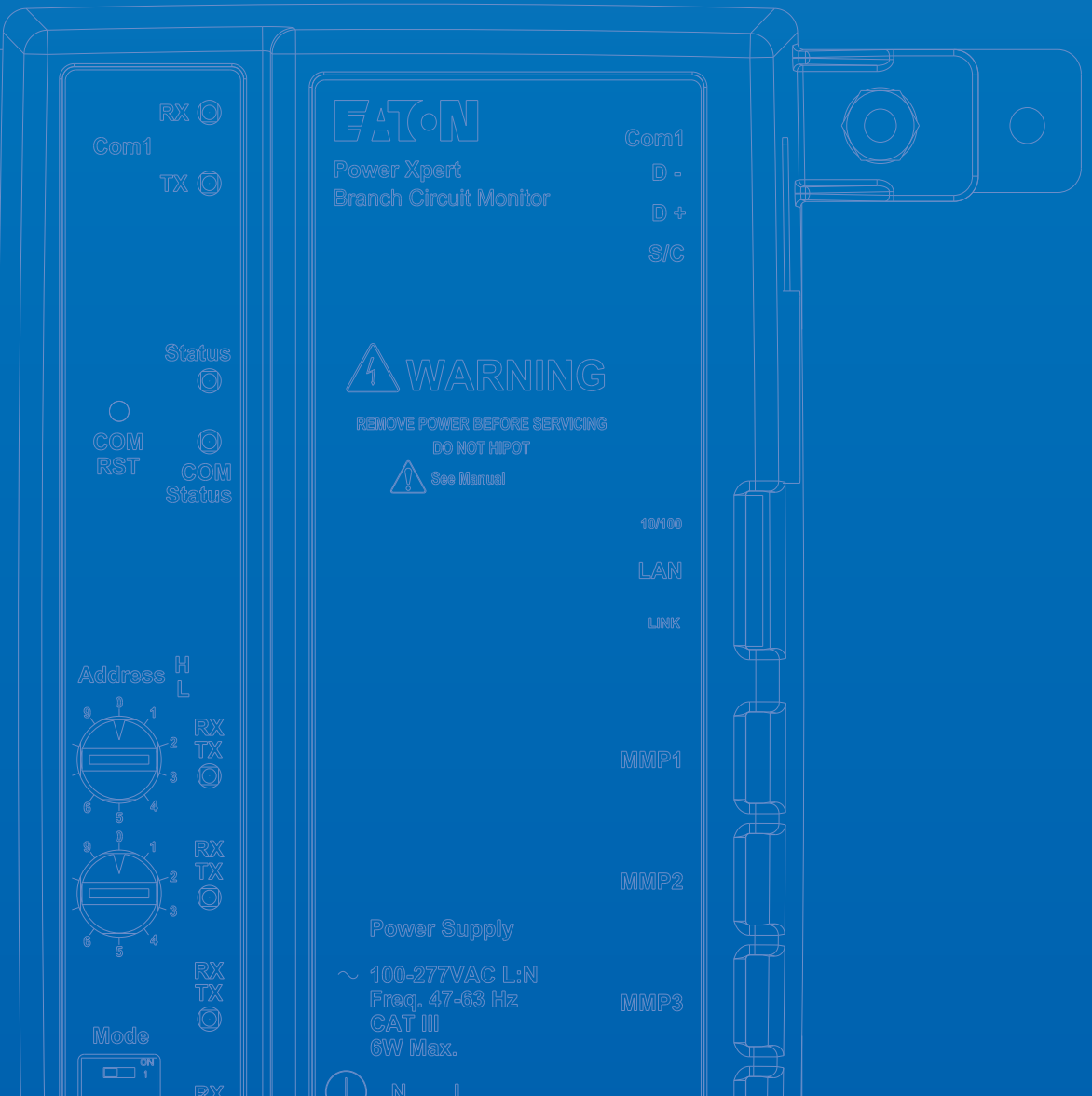
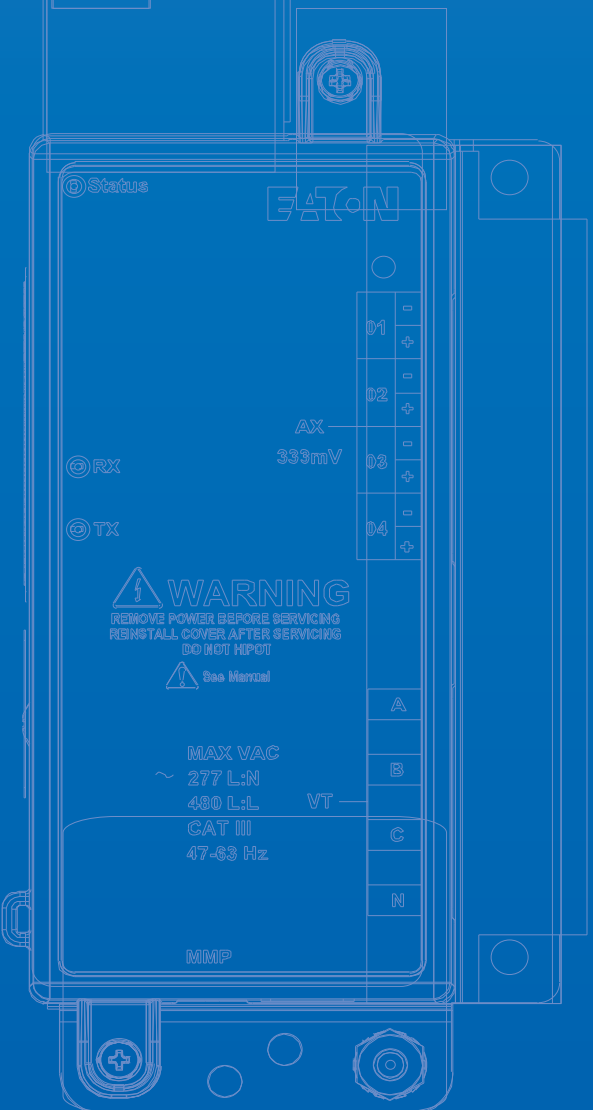



Table of Contents

Warnings.....	1	Voltage Monitoring: PXBCM-MMS and PXBCM-MME... 15	15
Cleaning.....	1	Single Phase, Two Wire.....	15
Catalog Numbers.....	1	Single Phase, Three Wire.....	16
Symbols Used in Diagrams.....	2	Three Wire Delta.....	16
Product Overview.....	2	Four Wire Wye.....	17
PXBCM-MB Meter Base.....	3	Three Wire Delta with Potential Transformers.....	17
PXBCM-MMS Meter Module Strips.....	3	Four Wire Wye With Potential Transformers.....	18
PXBCM-MME Meter Module External.....	4	Controls and Indicators on the PXBCM-MB.....	19
Stacking the PXBCM-MB and PXBCM-MME.....	4	Indicators on the PXBCM-MMS.....	20
Wiring.....	5	Indicators on the PXBCM-MME.....	21
Enclosures.....	5	Reference: Mounting Dimensions.....	22
Wiring the PXBCM-MMS.....	5	PXBCM-MB Mounting Dimensions.....	22
Wiring the PXBCM-MB.....	7	PXBCM-MMS Mounting Dimensions.....	22
Commissioning.....	8	PXBCM-MME Mounting Dimensions.....	23
Mounting and Wiring the PXBCM-MME Meter Module		Specifications.....	24
External.....	8	Power Xpert Branch Circuit Monitor: General.....	24
Mounting.....	8	Environmental.....	24
Wiring the PXBCM-MME Meter Module External.....	9	CE Mark.....	24
Current Load Connections.....	11	EMC (ElectroMagnetic Compatibility).....	24
120/208V, Three Wire Apartment Service.....	11	Safety.....	24
Three Phase, Four Wire Wye.....	12	Power Xpert Branch Circuit Monitor: Meter Base.....	24
480V Three Phase, Three Wire Panel Board Fed From		Power Supply.....	24
480Y/277 Solidly Grounded Wye Service.....	12	MMP1-4 Meter Module (MM) Port 1-4:.....	24
Three Phase, Four Wire Wye - Single Phase, One Pole		COM 1 RS485 serial port.....	24
Service.....	13	LAN Ethernet.....	25
120/240V, Single Phase, Three Wire Service.....	13	User Controls/Indicators.....	25
240V, Three Phase, Four Wire Delta Service.....	14	Power Xpert Branch Circuit Monitor: Meter Module Ex-	
120/240V, Three Wire, Single Phase.....	14	ternal.....	25
Three Wire, Single Phase.....	15	MMP - Meter Module Port.....	25
		VT - Voltage Terminal Metering.....	25



CT - Current Terminal - Branch Circuit Metering.....25
AX - Auxiliary Current Terminal - Auxiliary/Mains Me-
tering.....26
User Interface26
Power Xpert Branch Circuit Monitor: Meter Module
Strip26
MMP - Meter Module Port26
VT - Voltage Terminal Metering26
Glossary..... 27
Legal Statement..... 29



Warnings

WARNINGS

THE WARNINGS AND CAUTIONS INCLUDED AS PART OF THE PROCEDURAL STEPS IN THIS DOCUMENT ARE FOR PERSONNEL SAFETY AND PROTECTION OF EQUIPMENT FROM DAMAGE. AN EXAMPLE OF A TYPICAL WARNING CALL-OUT IS SHOWN ABOVE. THIS WILL HELP TO ENSURE THAT PERSONNEL ARE ALERT TO WARNINGS THAT MAY APPEAR THROUGHOUT THE DOCUMENT. IN ADDITION, CAUTIONS ARE ALL UPPER CASE AND BOLDFACED AS SHOWN BELOW.

WARNING

COMPLETELY READ AND UNDERSTAND THE MATERIAL PRESENTED IN THIS DOCUMENT BEFORE ATTEMPTING INSTALLATION, OPERATION, OR APPLICATION OF THE EQUIPMENT. ONLY QUALIFIED PERSONS SHOULD BE PERMITTED TO PERFORM ANY WORK ASSOCIATED WITH THE EQUIPMENT. THE WIRING, INSTALLATION AND APPLICATION USE INSTRUCTIONS PRESENTED IN THIS DOCUMENT MUST BE FOLLOWED PRECISELY. FAILURE TO DO SO COULD CAUSE PERMANENT EQUIPMENT DAMAGE, BODILY INJURY, OR DEATH.

WARNING

DO NOT ATTEMPT TO INSTALL OR PERFORM MAINTENANCE ON EQUIPMENT WHILE IT IS ENERGIZED. DEATH, SEVERE PERSONAL INJURY, OR SUBSTANTIAL PROPERTY DAMAGE CAN RESULT FROM CONTACT WITH ENERGIZED EQUIPMENT. ALWAYS VERIFY THAT NO VOLTAGE IS PRESENT BEFORE PROCEEDING WITH THE TASK, AND ALWAYS FOLLOW GENERALLY ACCEPTED SAFETY PROCEDURES. INSTALLATION MUST BE IN ACCORDANCE WITH ALL NATIONAL SAFETY CODES AND APPROPRIATE LOCAL CODES. EATON IS NOT LIABLE FOR THE MISAPPLICATION OR MISINSTALLATION OF ITS PRODUCTS.

Cleaning

The PXBCM components are maintenance free once properly commissioned. There are no user serviceable components or features.

Cleaning of the various PXBCM device housings should only be done with power and mains disconnected. A clean dry rag can be used to remove dust. No liquids should be used.





Catalog Numbers

Catalog Number	Description	Suffix Description	Notes
PXBCM-MB	Meter Base		
PXBCM-MMS-L09-A	Meter Module Strip	Left 9 CT	A= 1" Pitch, 100A
PXBCM-MMS-L15-A	Meter Module Strip	Left 15 CT	A= 1" Pitch, 100A
PXBCM-MMS-L21-A	Meter Module Strip	Left 21 CT	A= 1" Pitch, 100A
PXBCM-MMS-R09-A	Meter Module Strip	Right 9 CT	A= 1" Pitch, 100A
PXBCM-MMS-R15-A	Meter Module Strip	Right 15 CT	A= 1" Pitch, 100A
PXBCM-MMS-R21-A	Meter Module Strip	Right 21 CT	A= 1" Pitch, 100A
PXBCM-MME-X25-333MV	Meter Module eXternal	21+4 eXternal 333mV CT	X = eXternal CT
PXBCM-MMP-CBL6I	Meter Module Port Cable	Length 6"	
PXBCM-MMP-CBL01	Meter Module Port Cable	Length 1'	
PXBCM-MMP-CBL02	Meter Module Port Cable	Length 2'	
PXBCM-MMP-CBL03	Meter Module Port Cable	Length 3'	
PXBCM-MMP-CBL04	Meter Module Port Cable	Length 4'	
PXBCM-MMP-CBL06	Meter Module Port Cable	Length 6'	
PXBCM-MMP-CBL08	Meter Module Port Cable	Length 8'	
PXBCM-MMP-CBL12	Meter Module Port Cable	Length 12'	



Catalog Number	Description	Suffix Description	Notes
PXBCM-MMP-CBL16	Meter Module Port Cable	Length 16'	
PXBCM-MMP-CBL20	Meter Module Port Cable	Length 20'	
PXBCM-MMP-CBL28	Meter Module Port Cable	Length 28'	
PXBCM-MMP-CBLEX08	Meter Module Port Cable Ext.	Length 8'	
PXBCM-MMP-CBLEX16	Meter Module Port Cable Ext.	Length 16'	
PXBCM-DISP-6	BCM Local Display	6" Dia Display	
PXBCM-DISP-CBL04	BCM Local Display cable	4' Display cable	
PXBCM-DISP-CBL12	BCM Local Display cable	12' Display cable	

Symbols Used in Diagrams

Symbol	Description
	Fuse
	Switch
	Potential Transformer
	Ground
	Protective Earth

Product Overview

The Eaton Power Xpert Branch Circuit Monitor measures current, voltage, energy consumption, demand, and power factor for up to 100 load circuits. Each Meter Base can be connected to up to four Meter Modules in either a Strip or External configuration. The Meter Module Strips come in configurations of 9, 15, or 21 onboard current transformers (CTs) with terminals for up to four AX auxiliary 333mV CTs. The Meter Module External supports the same number of load circuits; however, they are all external 333mV CTs. All of the loads for each Meter Module must share a common mains Voltage connection.

Meter Module Strips are mounted on each side of a panel board, beside the breakers, and can monitor current for both both three phase and single phase branch circuits. Conductors pass through the onboard CTs before connecting to the breakers.

The Meter Modules can also monitor voltage in the following configurations:

- Three Phase, four wire wye
- Three phase, three wire delta
- Three phase, center tapped delta
- Three phase, three wire
- Single phase, two wire

The PXBCM-MB has a built-in web server and an Ethernet port, making for easy configuration through a familiar web interface. Through the web interface you can designate whether breakers for each meter module are wired in a sequential, alternating, or custom configuration. You can also set up "virtual meters," combining data from one, two, or three different phases into a energy meter. You can designate one of these virtual meters as the "main."

Product Overview

PXBCM-MB Meter Base



You can use the LAN port to connect the PXBCM-MB to your LAN. The PXBCM-MB supports both a fixed IP address and DHCP. Once on the LAN, you can access the web interface for real-time energy, power, current, and voltage information. Device configuration is done using the web interface. The LAN port also provides a Modbus TCP connection.

The COM1 port is a serial RS485 Modbus RTU interface to support a local Display or for related monitoring purposes. An optional PXBCM-DISP-6 local display is available. You can connect the PXBCM to a building management system or other upstream monitoring software using either the Modbus RTU (COM1) or Modbus TCP (LAN) interface.

To preserve your settings, in case you must either replace a PXBCM-MB or reset it to factory settings, you can save all of your configuration information to a file. Configuration files can be uploaded to the PXBCM-MB. If you're configuring multiple identical PXBCM systems, you can set up a single configuration file and upload this to multiple PXBCM-MBs.

The MB may either be factory mounted in a panel board or with the MME in an appropriate separate enclosure. The MME can be mounted in approved panel boards. The MMS can only be mounted in UL approved panel boards or appropriate separate enclosures.

PXBCM-MB Meter Base

The PXBCM-MB is the data acquisition module of the PXBCM system. The PXBCM-MB aggregates the data channels from the PXBCM-MMS and from the PXBCM-MME. You can access the data from all channels (including virtual meters)

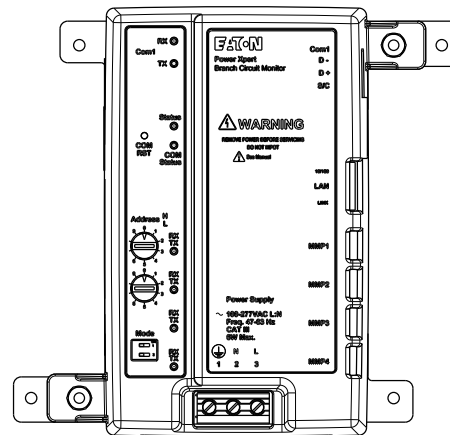

PXBCM-MB

through the RS485 COM1 Modbus port using the RS-485 RTU protocol, or the LAN Modbus TCP connection, or view it directly through the onboard web server.

The MB is powered through a single-phase connection to the panel mains. The power connection (marked Power Supply on the MB) must be equipped with both a fuse block and disconnect switch.

The Modbus address is set through a pair of rotary switches (Address H-L) on the front of the PXBCM-MB housing. Indicator lights show device status (Status) as well as communications status for both Ethernet (COM Status) and Modbus (Com1 TX/RX). Indicators show the data Rx/Tx transfer activity.

PXBCM-MMS Meter Module Strips

Meter Module Strips (PXBCM-MMS) are available in configurations to mount on either the left or right of a panel board and contain 9, 15, or 21 CTs. Four additional connections are provided for AX Auxiliary CT connections, which can be used to monitor the panel mains or branch circuits. The MMS has both load current and voltage metering circuits providing meter data to the Meter Base. Power must be supplied via the PXBCM-MMP-CBL cable for the Meter Module to operate.



PXBCM-MMS - left



PXBCM-MME Meter Module External

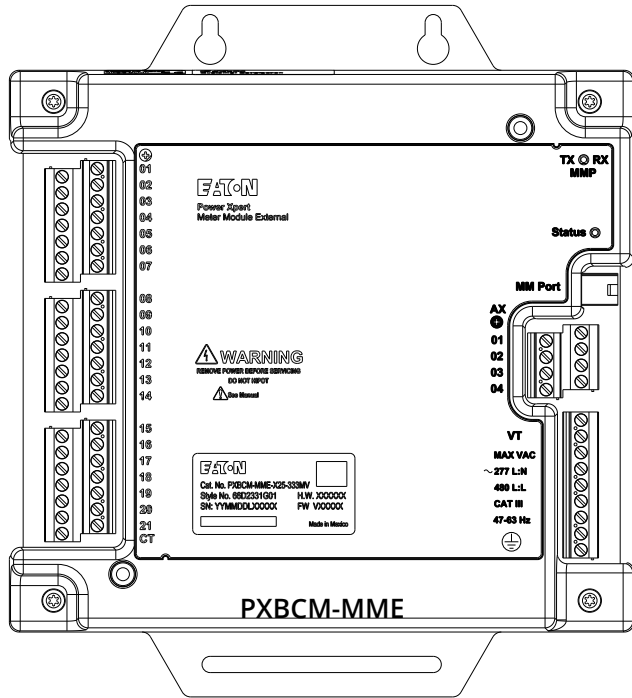

Designed primarily for retrofit or high mix panel board applications, the MME provides connections for up to 25 external CTs as well as voltage measurement capability. Like the PXBCM-MMS, the PXBCM-MMP-CBL-*nn* cable provides both a data connection to the PXBCM-MB and power to the PXBCM-MME from the PXBCM-MB.

For retrofit applications the MME must be housed in an appropriate enclosure adjacent to the existing panel board or similar power distribution assembly. The Meter Base can share this enclosure. The MME can also be used in approved panel boards where a high mix of breakers does not fit the MMS. The Meter Module Ports support a maximum distance of 28 ft between the Meter Base and a Meter Module. For shipping split or similar reasons this MMP cable can be split in two sections using the PXBCM-MMP-CBLE cable extension in either 8 or 16 ft lengths.

Stacking the PXBCM-MB and PXBCM-MME

If you're using the PXBCM-MME and mounting it in the same factory mounted assemblies as the PXBCM-MB, you can mount the MB directly to the MME to save space.

The MB mounts directly to the face of the MME using two #8-32 x 0.5 in screws, as shown in the following figure. The bottom figure shows the devices in the stacked configuration.

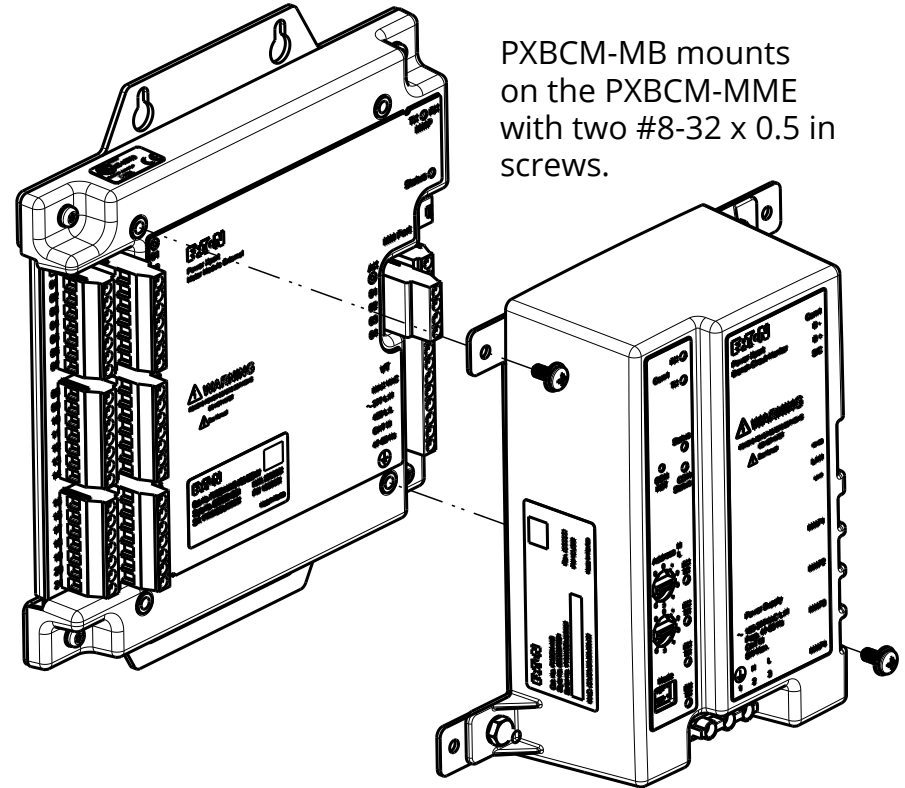

PXBCM-MB mounts on the PXBCM-MME with two #8-32 x 0.5 in screws.

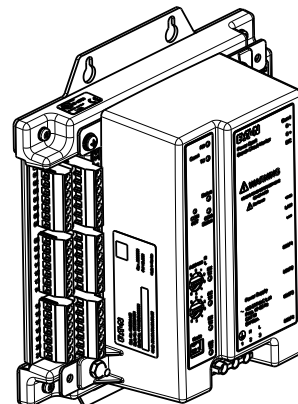

The PXBCM-MB and PXBCM-MME in the stacked configuration.

Wiring

⚠ WARNING!

DO NOT ATTEMPT THESE PROCEDURES WHILE EQUIPMENT IS ENERGIZED. DEATH, SEVERE PERSONAL INJURY, OR SUBSTANTIAL PROPERTY DAMAGE CAN RESULT. ALWAYS VERIFY THAT NO VOLTAGE IS PRESENT BEFORE PROCEEDING (LOCK OUT/TAG OUT).

Enclosures

The PXBCM-MMS and Meter Base have been installed at the factory in approved panel board such as the Eaton Pow-R-Line 1a, 2a, or 3e. The figure to the right shows one of several possible factory mounting arrangements in a Pow-R-Line panel, with the PXBCM-MB mounted below the breakers. The PXBCM-MB can also be mounted above the breakers or, for larger panels, between two sets of breakers.

Note the fuse block and disconnect switch.

Wiring the PXBCM-MMS

1. Remove the covers from each PXBCM-MMS by removing the two retaining screws.

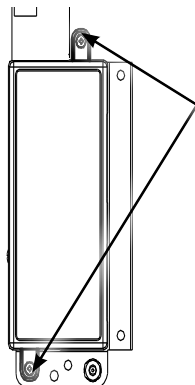

Remove these screws to remove PXBCM-MMS cover.

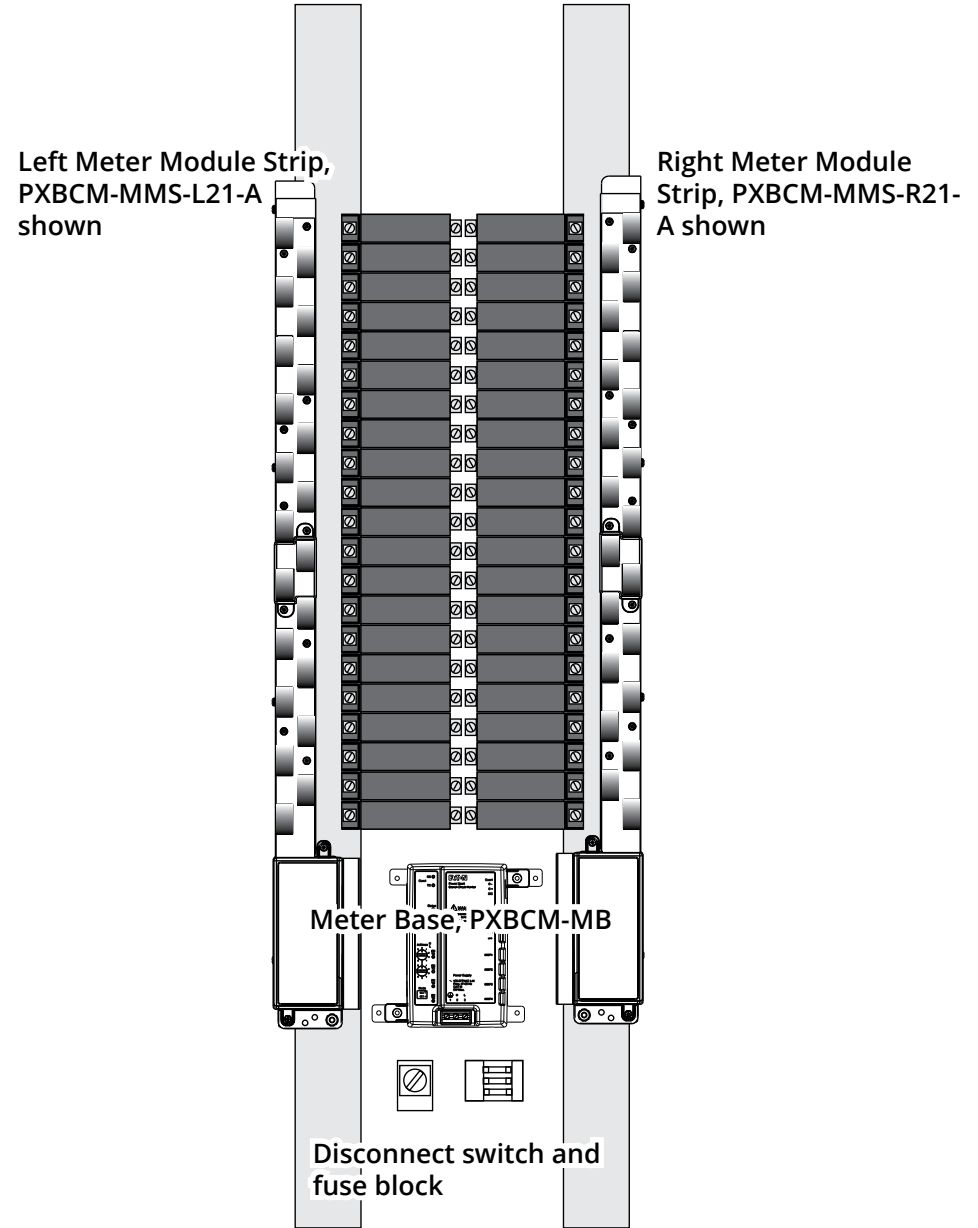

One of several possible PXBCM mounting arrangements



2. Wire the circuit breaker three-phase or single-phase load conductors through the CTs. The CTs are rated for 100 A and can handle up to 1/0 AWG THHN or similar wire. The CT inside diameter is 0.484 in. The configuration software, by default, expects that the breakers are in odd-even order, but this can easily be changed to sequentially ordered breakers.
3. To monitor current for power system phases A, B, C, and N, connect four external 333mV CTs appropriately sized for the application. AX Auxiliary terminal blocks for these CT connections are on the PXBCM-MMS and shown in the figure to the right. By default, the configuration software expects the following AX connections on the PXBCM-MMS:
 - 1&2: Phase A
 - 3&4: Phase B
 - 5&6: Phase C

You can reconfigure this in the configuration interface if necessary.
4. Connect mains connections from the disconnect switch/ fuse block and neutral to the VT Voltage Terminal connections as shown to the right.
5. Connect a protective earth safety ground to the PE stud below the the VT terminal block, as shown in the figure to the right.
6. Connect the PXBCM-MMP-CBL nn Meter Module Port cable (from the PXBCM-MB) to each PXBCM-MMS as shown to the right.
7. Re-install the PXBCM-MMS cover.

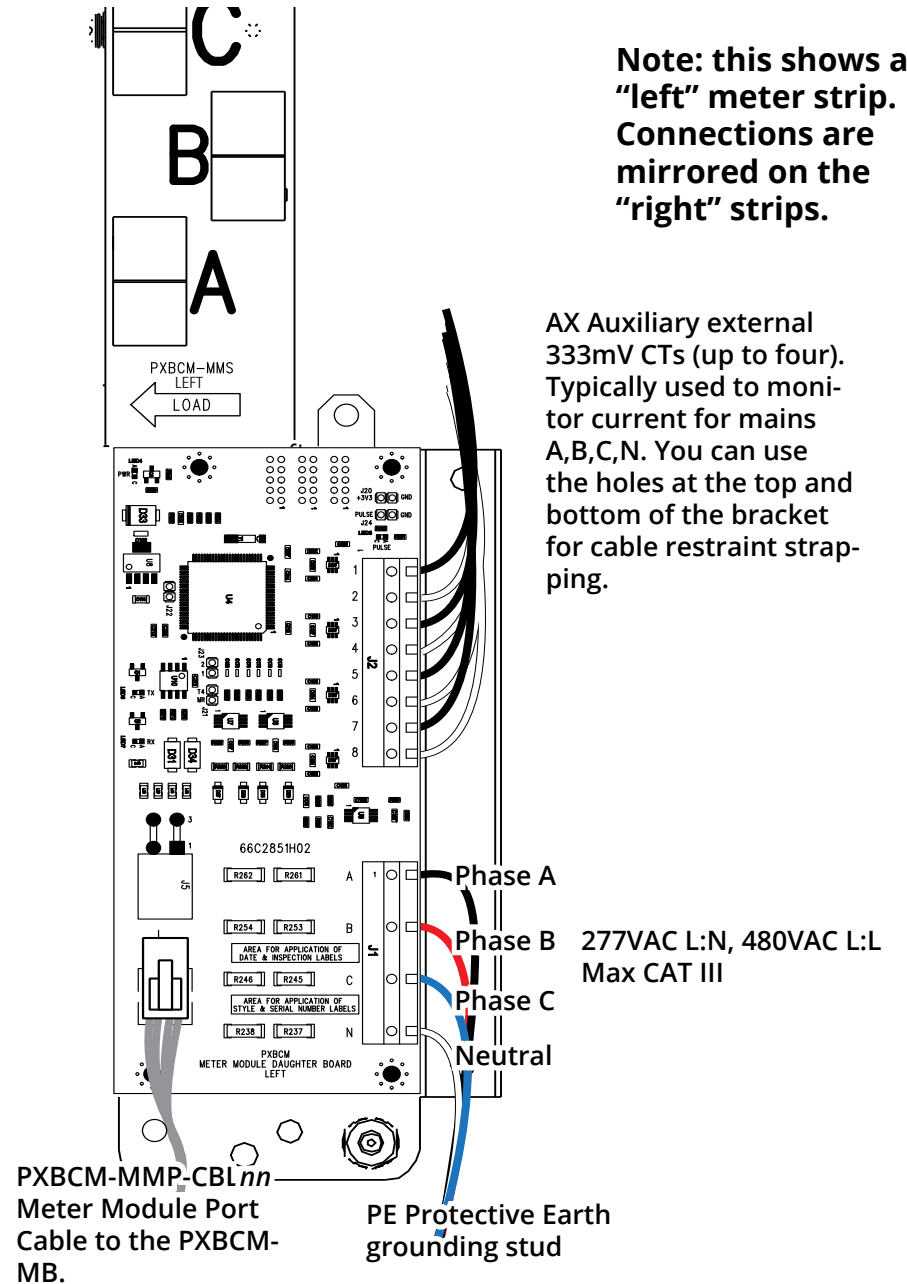

Wiring the PXBCM-MB

WARNING!

DO NOT ATTEMPT THESE PROCEDURES WHILE EQUIPMENT IS ENERGIZED. DEATH, SEVERE PERSONAL INJURY, OR SUBSTANTIAL PROPERTY DAMAGE CAN RESULT. ALWAYS VERIFY THAT NO VOLTAGE IS PRESENT BEFORE PROCEEDING (LOCK OUT/TAG/OUT).

Note: Route the Ethernet and Modbus cables separately from the PXBCM-MMP-CBL Meter Module Port Cables and power supply cables.

1. Connect a single phase of the power system to the Power Supply terminal block as shown in the figure to the right. Note that you must employ a disconnect switch and fuse block between the power system and the Power Supply terminal block on the PXBCM-MB. The fuse should be sized/rated to protect the wire.
2. Connect the Modbus cable to the COM 1 terminal connector using cable designed for RS485 operation. The three position terminal supports data -/+ and RS485 common/shield. The maximum run is 4,000 ft (1220 M) 9600-38.4 kbaud, 2,000 ft (610 M) 56-115.2 kbaud.
3. Connect the PXBCM-MB to a laptop for configuration or to the LAN. The LAN port accepts an RJ45 connector. Use a CAT 5 or better Ethernet cable. Note that the maximum cable run is 425 ft (130 M). Shielded Twisted Pair (STP) is required for full EMC performance
4. Connect the PXBCM-MMP-CBL nn cables from all PXBCM-MMS or PXBCM-MME to the PXBCM-MB using the MMP1 through MMP4 connectors. You can use either side of the cable. The configuration software expects MMP1 to be the top left PXBCM-MMS strip; MMP2, to be the top, right strip; and so on. However, this can be easily changed in the configuration interface.

PXBCM-MB Meter Base Wiring

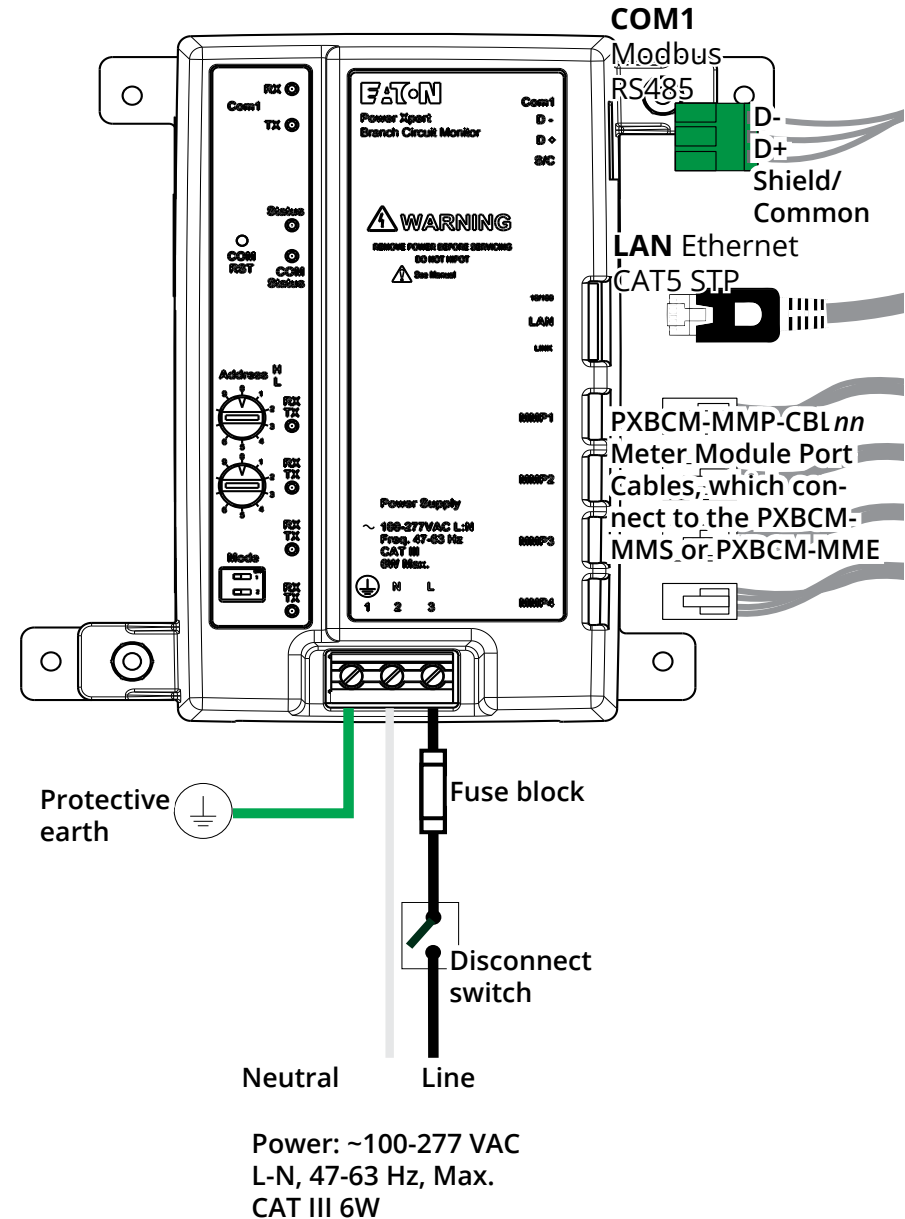

Commissioning

WARNING!

IT IS IMPERATIVE THAT THE POWER LOCK OUT TO THE ASSEMBLY BE VERIFIED TO BE OFF AND KEPT OFF DURING THIS PROCESS. DEATH, SEVERE PERSONAL INJURY, OR SUBSTANTIAL PROPERTY DAMAGE CAN RESULT.

For commissioning or debugging purposes, with the monitored power distribution assembly mains power shut down and locked out, it is possible for trained personal to temporarily apply power to just the PXBCM meter system. In panel board applications this assembly shut down would allow the panel trim to be removed for access to the PXBCM.

By applying power from an external source to just the PXBCM-MB Power Supply terminal, all of the electronics of the PXBCM-MB and the Meter Module Port connected PXBCM-MMS and PXBCM-ME can be energized.

The normal connections to the PXBCM-MB Power Supply must be disconnected during this process.

The metering values will be zeroed; however, all of the switches, LED indicators, and communication functionality will be accessible and active. This approach can be useful to configure and verify many of the details required for proper commissioning of the PXBCM.

After completion of this review, return the PXBCM Meter Base Power supply connections to the normal fuse and disconnect switch connections. When the overall assembly gear commissioning is complete and system power is applied, access to the PXBCM will be limited to communications from cables routed out of the assembly.

Mounting and Wiring the PXBCM-MME Meter Module External

The PXBCM-MME provides the same functionality as the PXBCM-MMS for retrofit or non-uniform/high-mix load applications. Unlike the PXBCM-MMS, the PXBCM-MME relies entirely on external CTs. These can be either solid or split-core 333mV CTs, which can be easily attached to existing panel wiring.

Mounting

The PXBCM-MME must be housed in an appropriate NEMA or UL enclosure that ensures the device will remain within its specified environmental ranges and provides fire and mechanical protection. In retrofit applications the MME must be mounted in an enclosure external from the monitored assembly gear, only the CTs should be within the existing panel unless the MME is an approved accessory for the assembly.

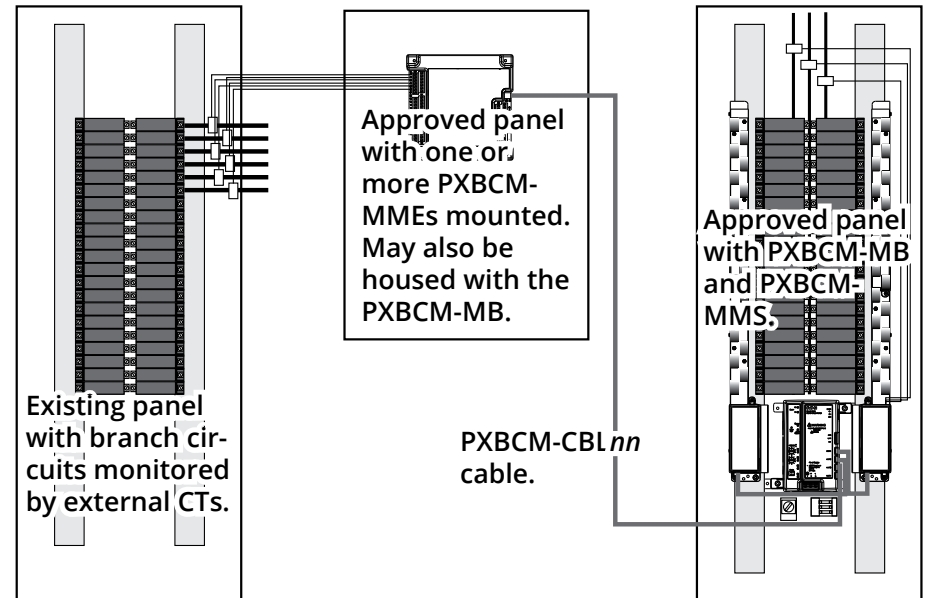



Multiple PXBCM-MMEs can be installed in the same enclosure and with the MB. The previous figure shows one possible mounting scheme; however, you can have any combination of a total of four MME and MMS.

To reach the external enclosure(s) you can use the PXBCM-MMP-CBL nn cable plus the PXBCM-MMP-CBLE nn extension cable, but do not exceed 28 ft (8.53 m). Note that the MME can be mounted either vertically or horizontally.

See “PXBCM-MME Mounting Dimensions” on page 23 for a mounting diagram.

Wiring the PXBCM-MME Meter Module External

⚠ WARNING!

DO NOT ATTEMPT THESE PROCEDURES WHILE EQUIPMENT IS ENERGIZED. DEATH, SEVERE PERSONAL INJURY, OR SUBSTANTIAL PROPERTY DAMAGE CAN RESULT. ALWAYS VERIFY THAT NO VOLTAGE IS PRESENT BEFORE PROCEEDING (LOCK OUT/TAG/OUT).

1. Attach up to 21 333mV external CTs, rated for the application, to the CT terminal blocks on the PXBCM-MME. These are dual-tier terminal blocks, with the back/high tier for positive inputs and the front/lower tier for negative inputs.

External CTs should provide basic isolation between primary load cable to secondary, UL qualified to:

- UL61010-1
- UL2808
- UL/ANSI C57.13

2. The configuration software, by default, expects that the breakers are in odd-even order, but this can easily be changed to sequentially ordered breakers.

3. Attach up to 4 333mV external CTs, rated for the application, to the Auxiliary AX terminal blocks on the PXBCM-MME. Like the CT circuits these are dual-tier terminal blocks with the back/high tier for positive inputs and the front/lower tier for negative inputs. The typical use case is to monitor the panel feeder load cables. By default, the configuration software expects the following terminal block connections on the PXBCM-MMS:
 - 01: Phase A
 - 02: Phase B
 - 03: Phase C

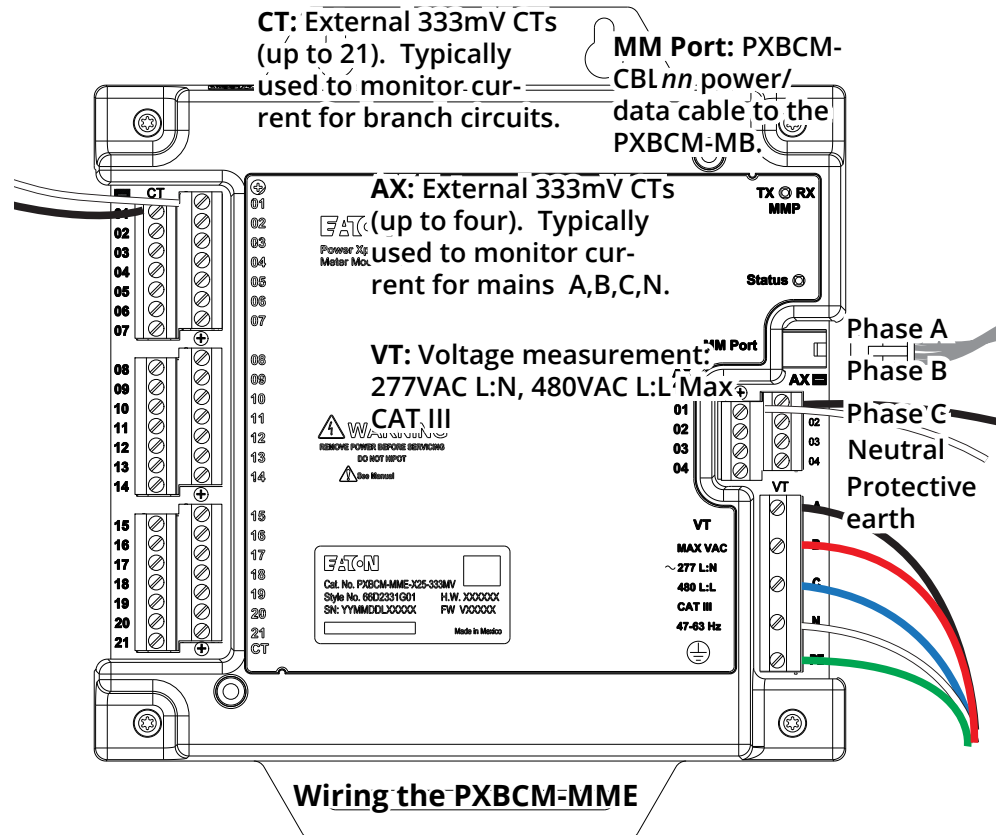



You can reconfigure this in configuration interface if necessary.

4. Connect power from the disconnect switch/fuse block and neutral to the VT voltage terminal connections, as shown in the previous figure.
5. Connect the PXBCM-MMP-CBL nn power/data cable (from the PXBCM-MB) to the PXCBM-MME as shown in the previous figure.



Current Load Connections

The following figures show supported CT connection schemes for the PXBCM-MME.

These diagrams depict the X1 CT wire color as white and X2 as black. The use of white wire for X1 and black wire for X2 is not universal. Always verify the polarity of current sensors by checking the CT documentation. Reverse polarity can be corrected either by swapping the white and black wires or polarity can be re-configured using BCM configuration web page.

Voltage monitoring connections may be found in the next chapter.

120/208V, Three Wire Apartment Service

208Y/120 Three Phase, Four Wire Wye Service
Single Phase, 120/208V, Three Wire Network Loads
CT Connections

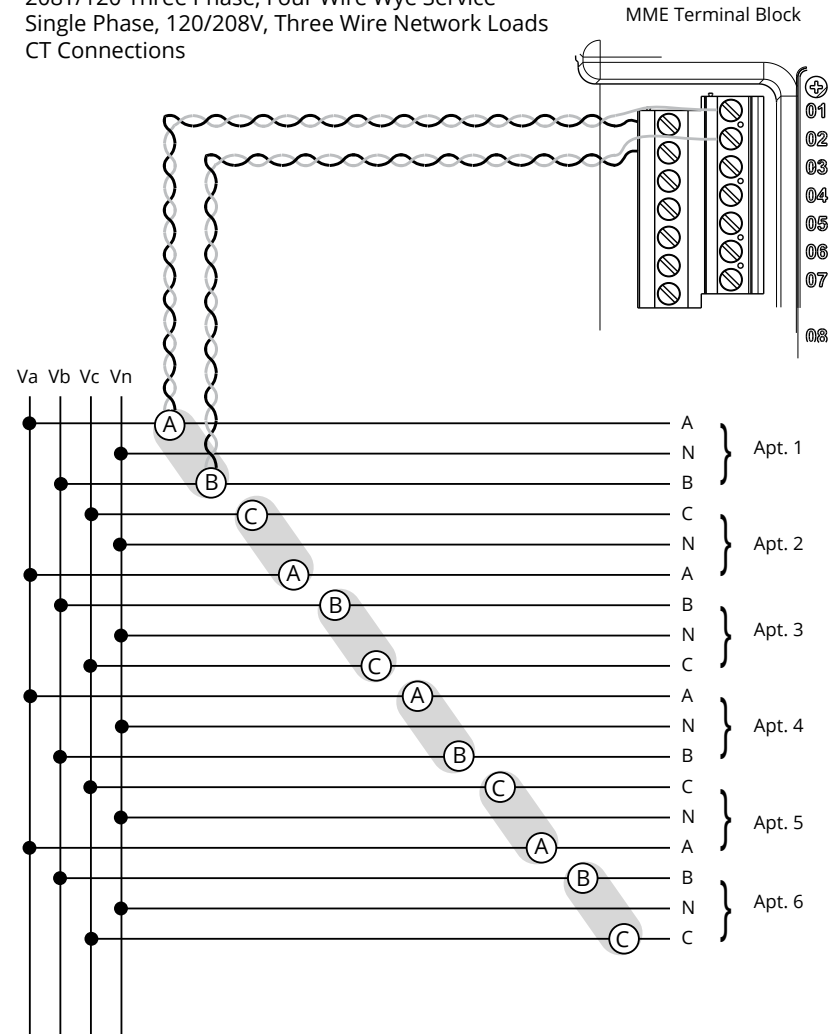

CT Diagram 1: 120/280V, Three Wire Apartment Service



Three Phase, Four Wire Wye

Three Phase - Four Wire Wye Service
CT Connections

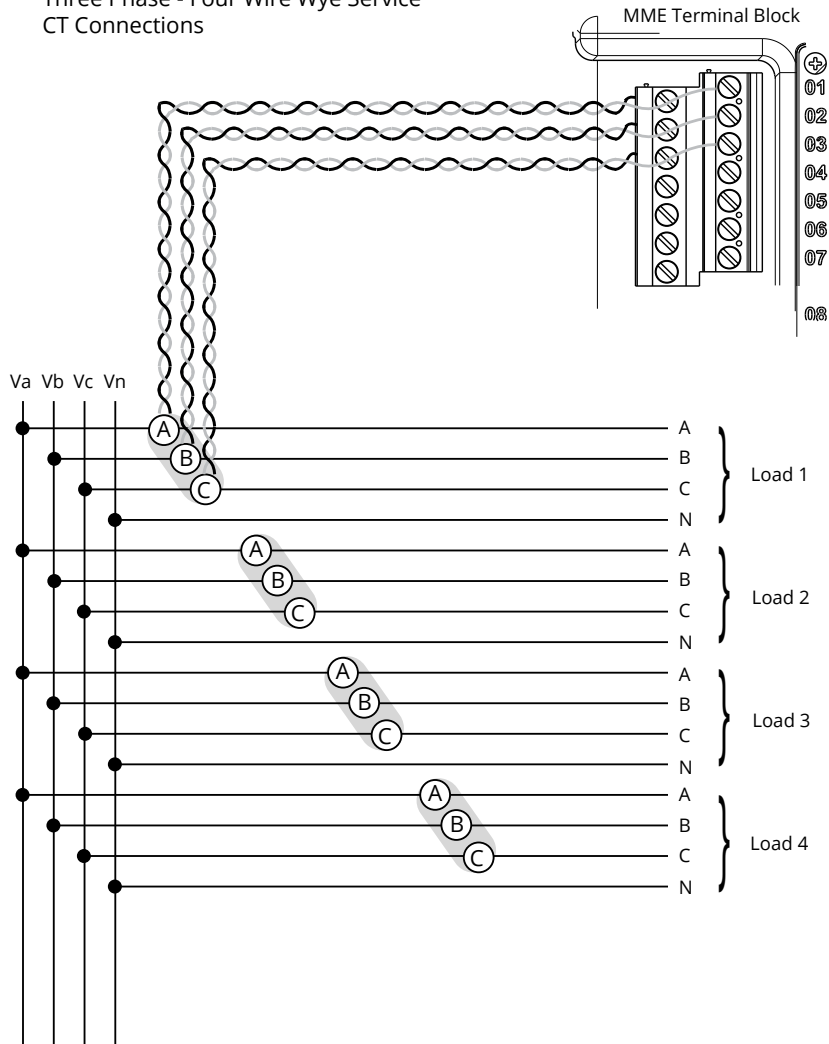

CT Diagram 2: Three Phase, Four Wire Wye

480V Three Phase, Three Wire Panel Board Fed From 480Y/277 Solidly Grounded Wye Service

480V Three Phase, Three Wire Panel Board Fed
From 480Y/277 Solidly Grounded Wye Service

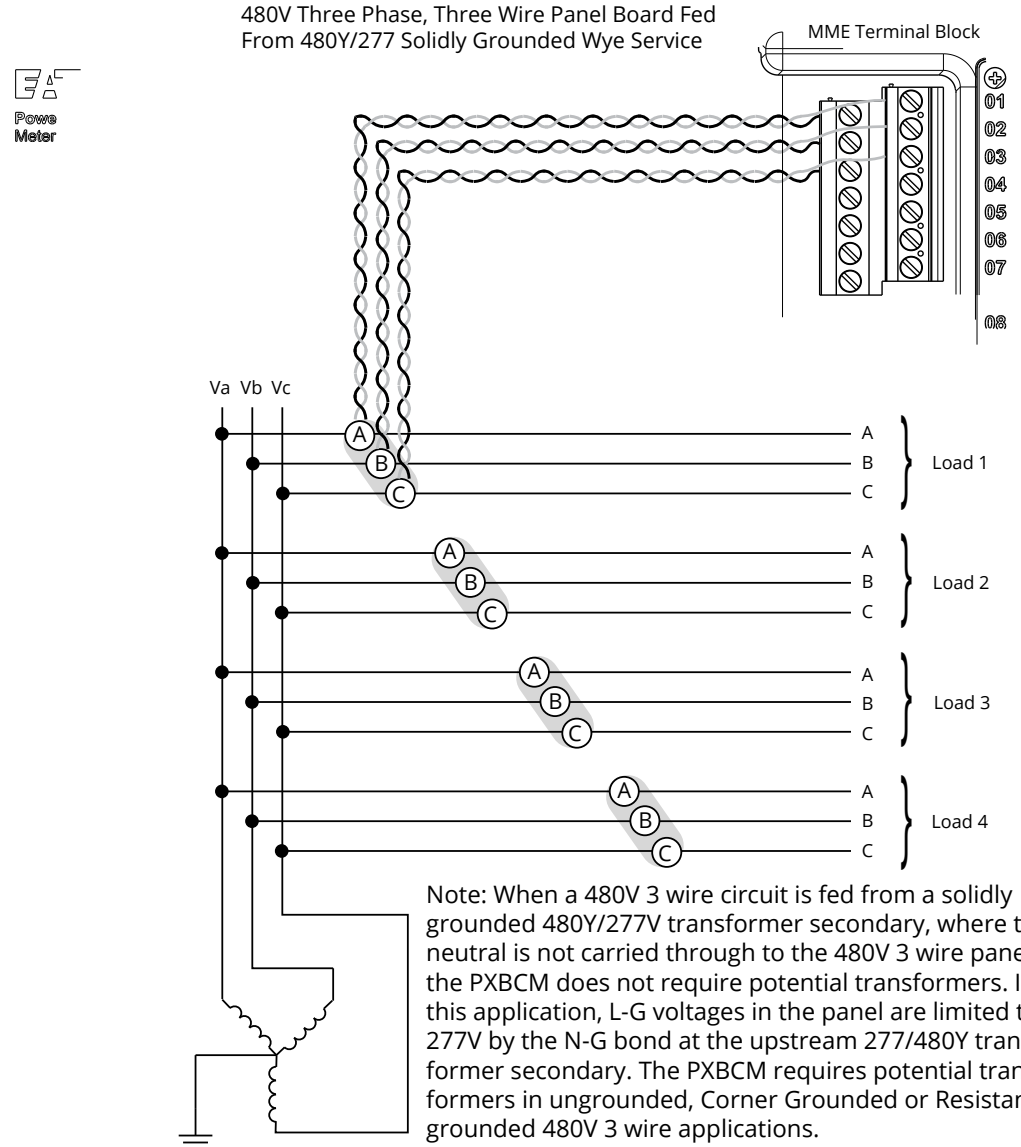

Note: When a 480V 3 wire circuit is fed from a solidly grounded 480Y/277V transformer secondary, where the neutral is not carried through to the 480V 3 wire panel, the PXBCM does not require potential transformers. In this application, L-G voltages in the panel are limited to 277V by the N-G bond at the upstream 277/480Y transformer secondary. The PXBCM requires potential transformers in ungrounded, Corner Grounded or Resistance grounded 480V 3 wire applications.

CT Diagram 3: 480V Three Phase Three Wire Panel Board fed from 480Y/277 Solidly Grounded Wye Service



Three Phase, Four Wire Wye - Single Phase, One Pole Service

Three Phase - Four Wire Wye Service -
Single Phase One Pole
CT Connections

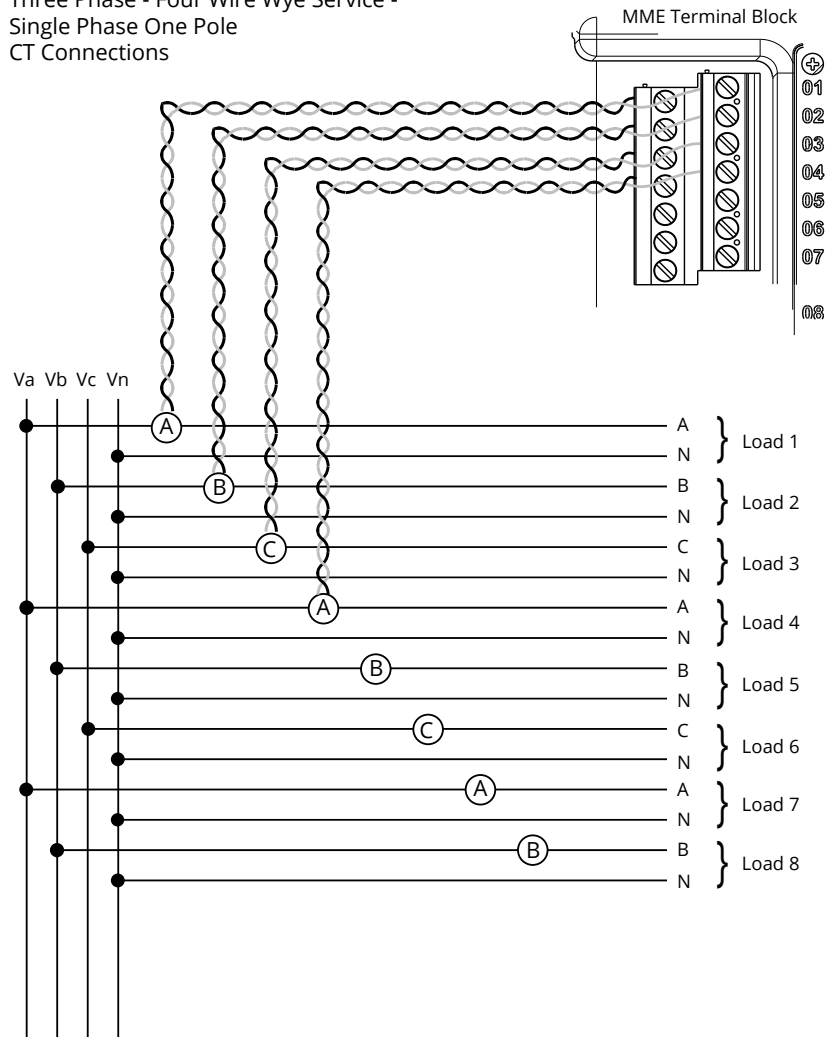

CT Diagram 4: Three Phase, Four Wire Wye - Single Phase, One Pole Service

120/240V, Single Phase, Three Wire Service

120/240 Single Phase, Three Wire Service
CT Connections

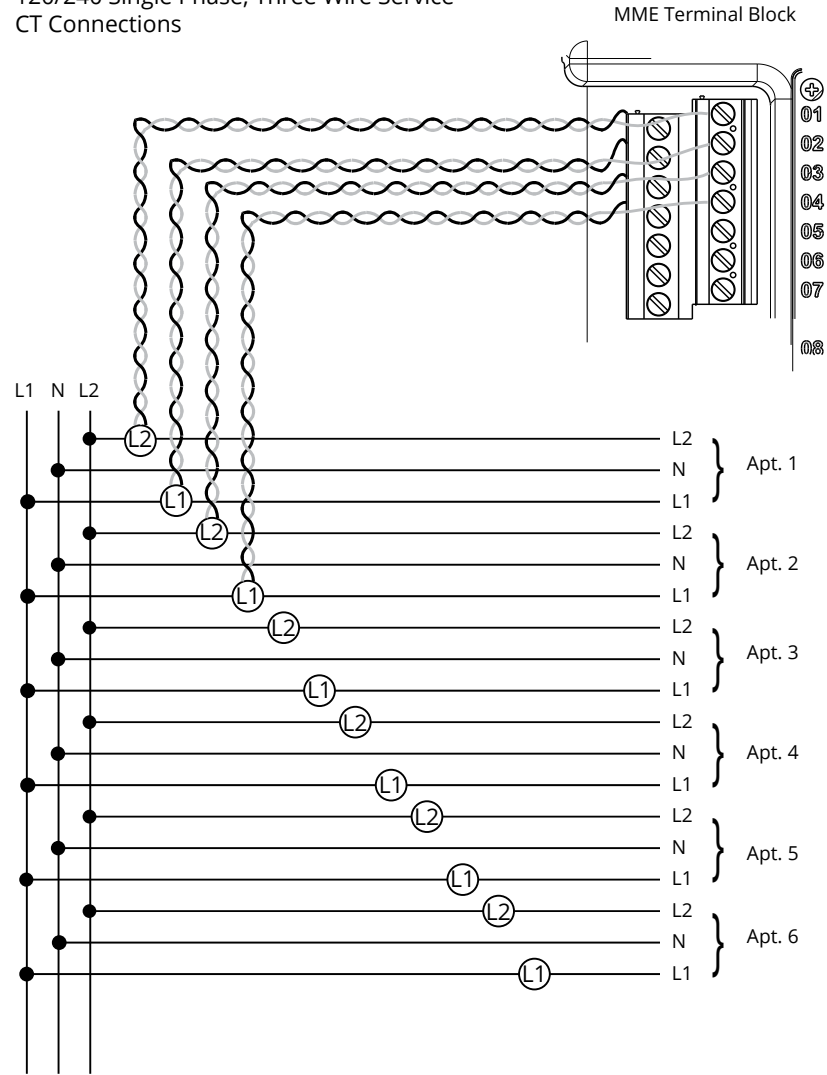

CT Diagram 5: 120/240V, Single Phase, Three Wire Service



240V, Three Phase, Four Wire Delta Service

240V Three Phase - Four Wire Delta Service
CT Connections

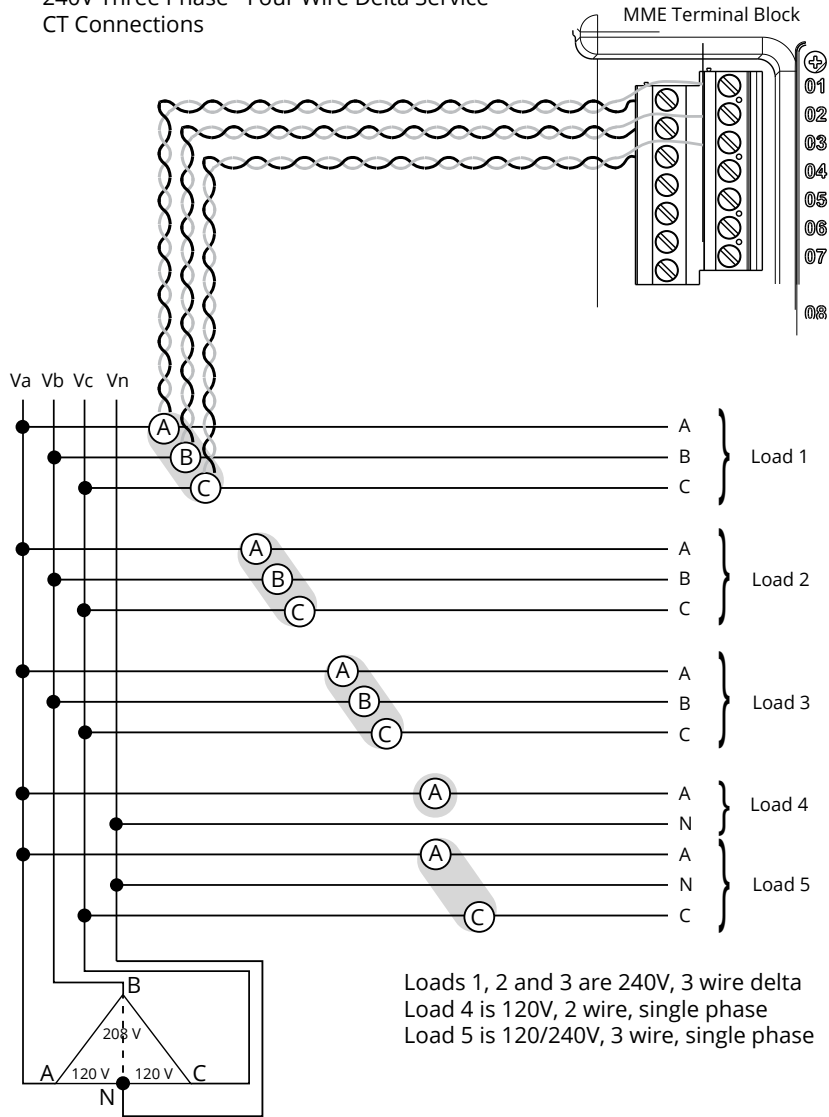

CT Diagram 6: 240V, Three Phase, Four Wire Delta Service

120/240V, Three Wire, Single Phase

120-240V Three Wire, Single Phase
CT Connections

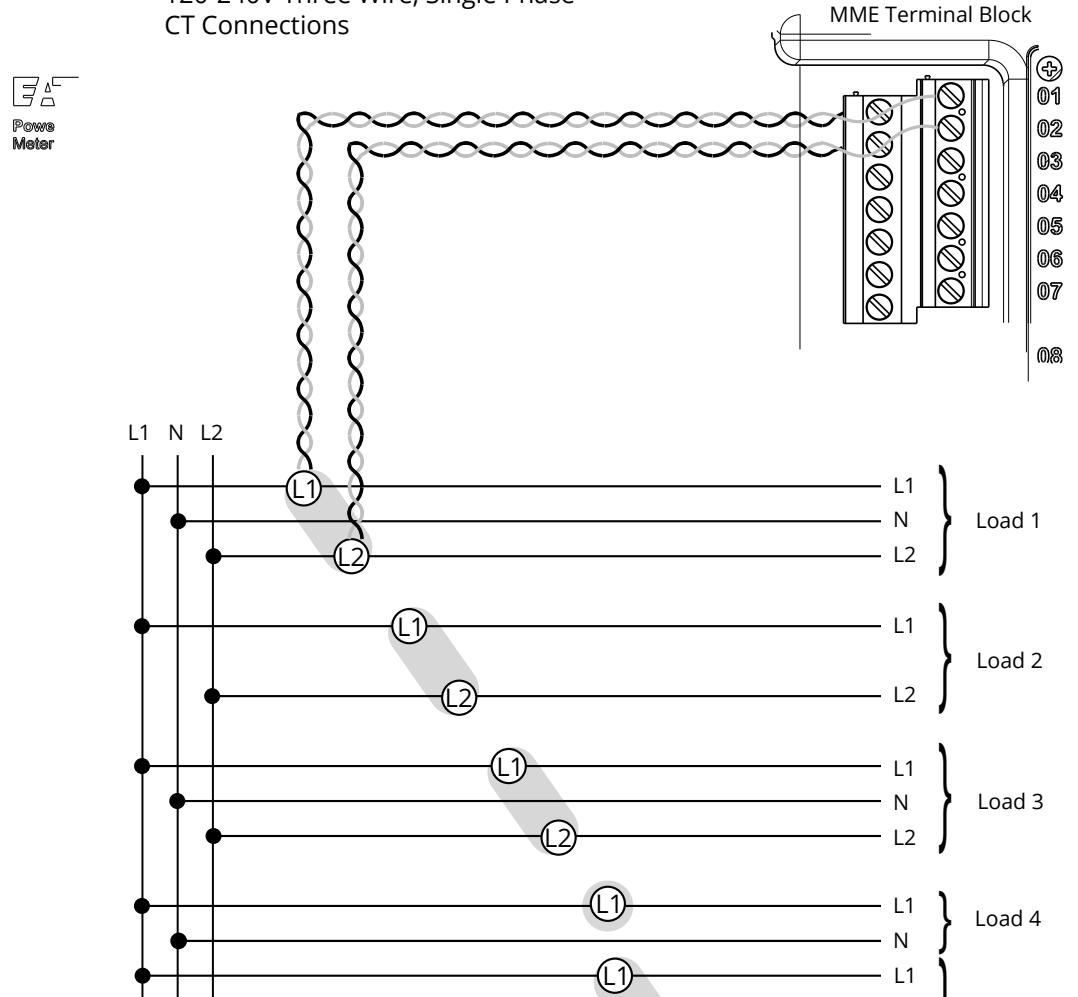

CT Diagram 7: 120/240V, Three Wire, Single Phase



Three Wire, Single Phase

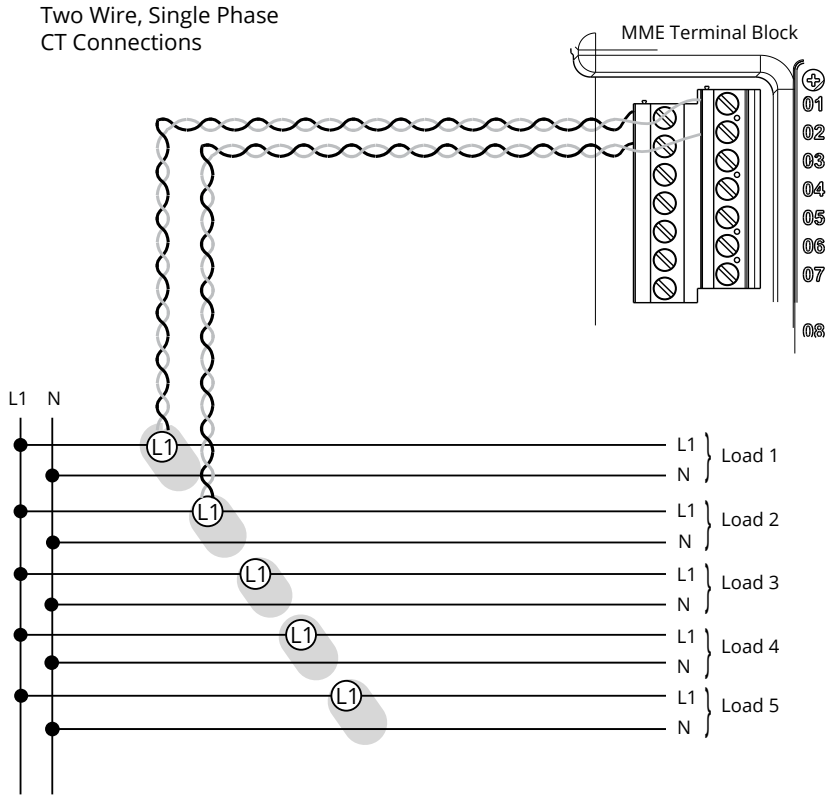

CT Diagram 8: Two Wire, Single Phase

Voltage Monitoring: PXBCM-MMS and PXBCM-MME

The following diagrams show supported voltage monitoring connection schemes for the PXBCM-MMS and PXBCM-MME. Note that the PXBCM-MMS does not have a PE connection on the VT terminal block but instead has a grounding stud.

Single Phase, Two Wire

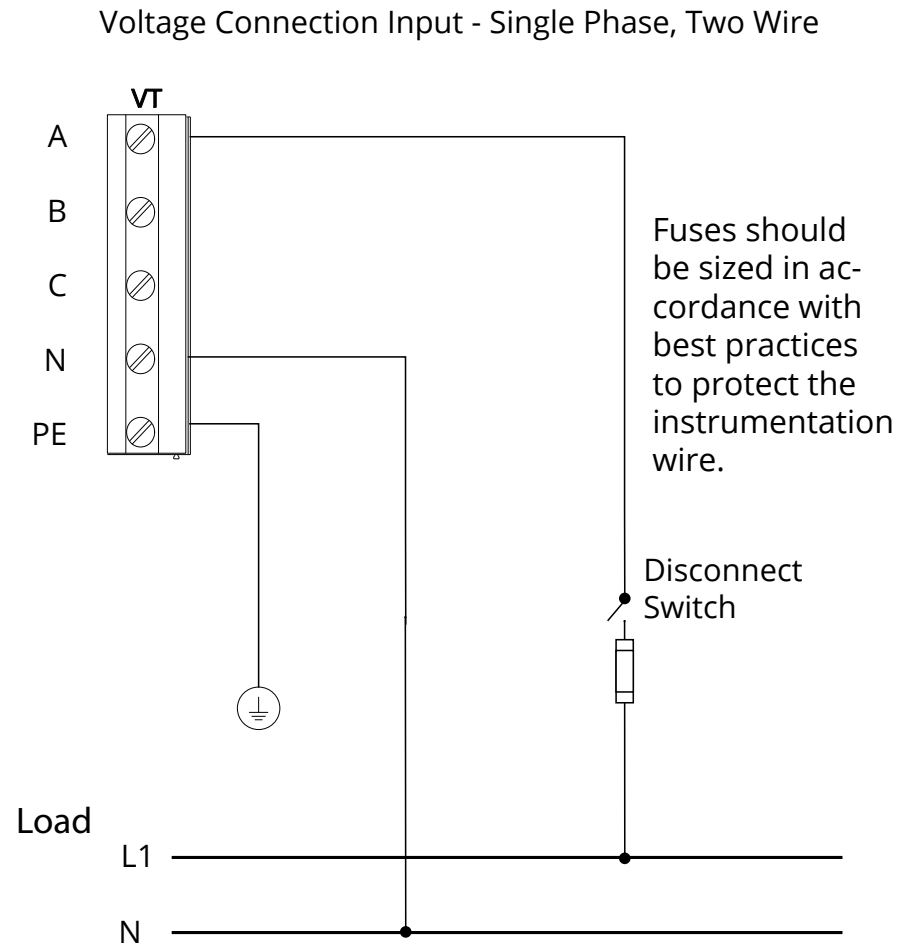

Voltage Monitoring Diagram 1: Single Phase, Two Wire



Single Phase, Three Wire

Voltage Connection Input - Single Phase Three Wire

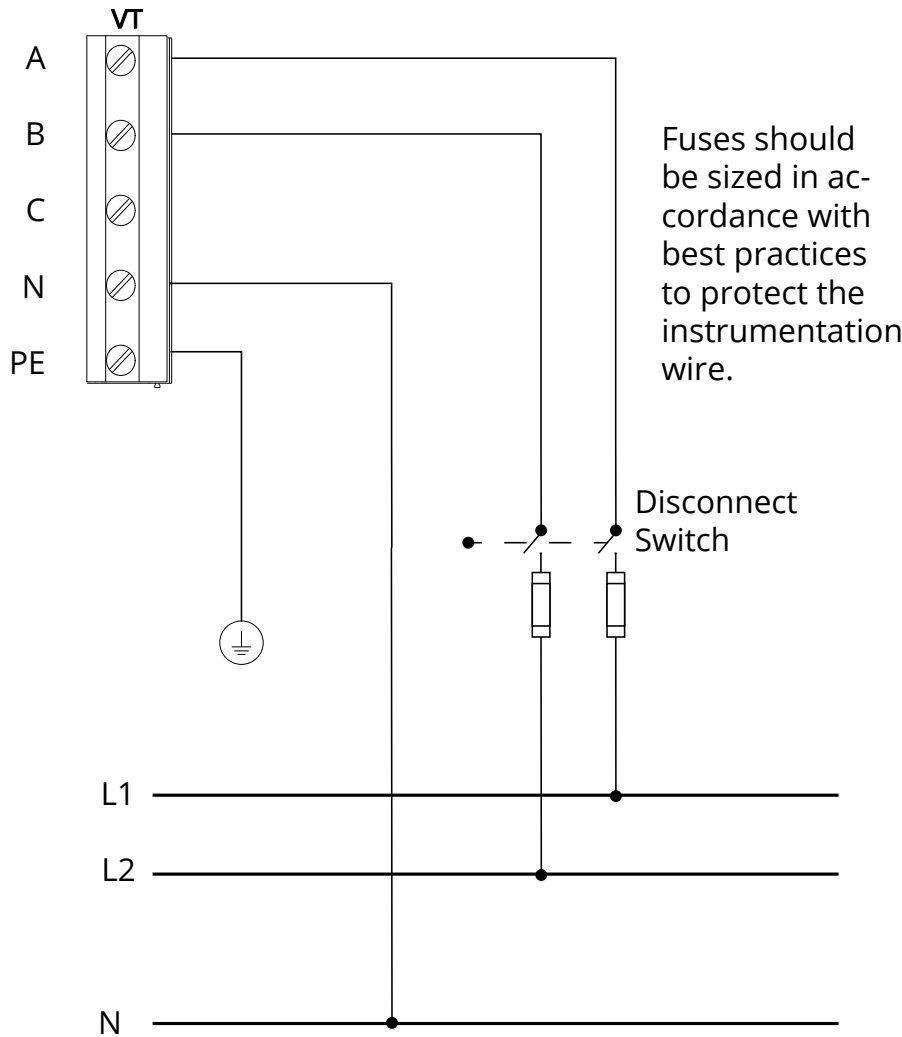

Voltage Monitoring Diagram 2: Single Phase, Three Wire

Three Wire Delta

Voltage Connection Input - Four Wire Delta

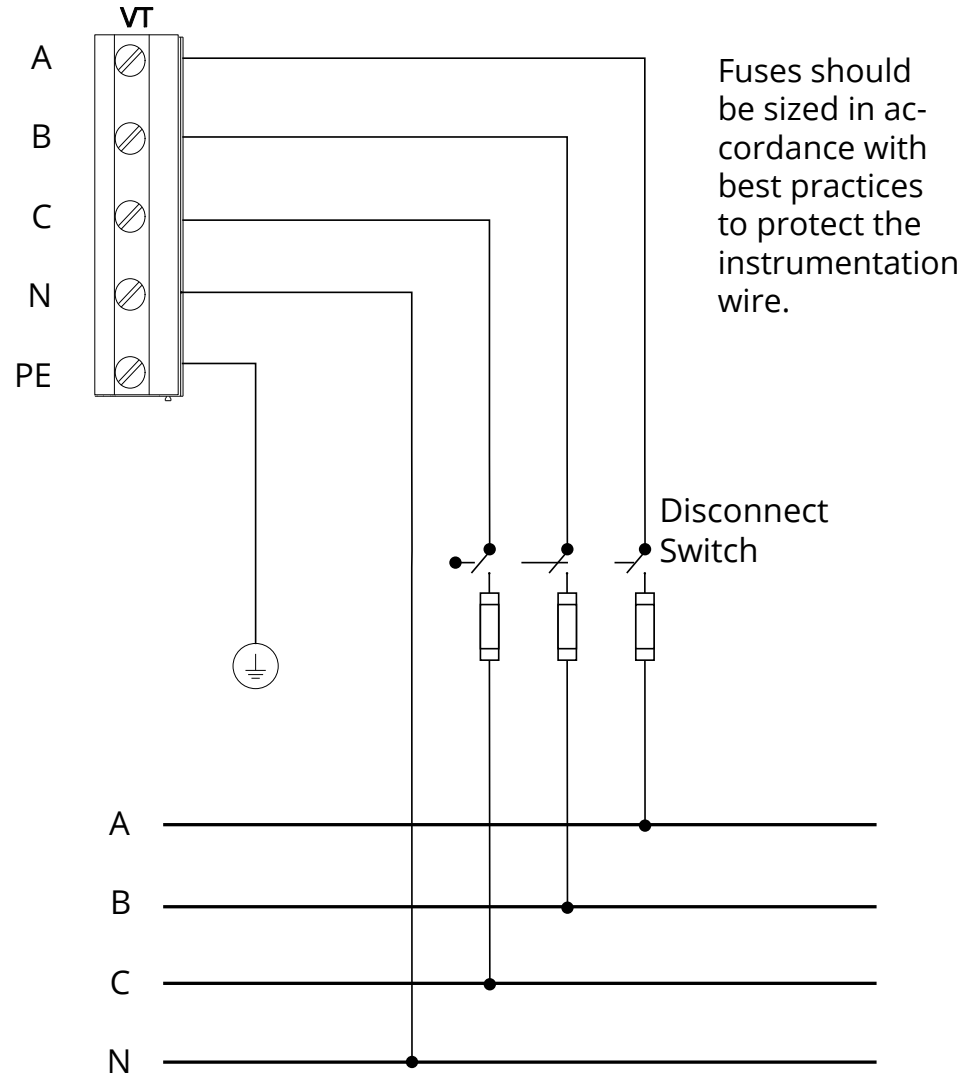

Voltage Monitoring Diagram 3: Three Wire Delta



Four Wire Wye

Voltage Connection Input - Four Wire Wye

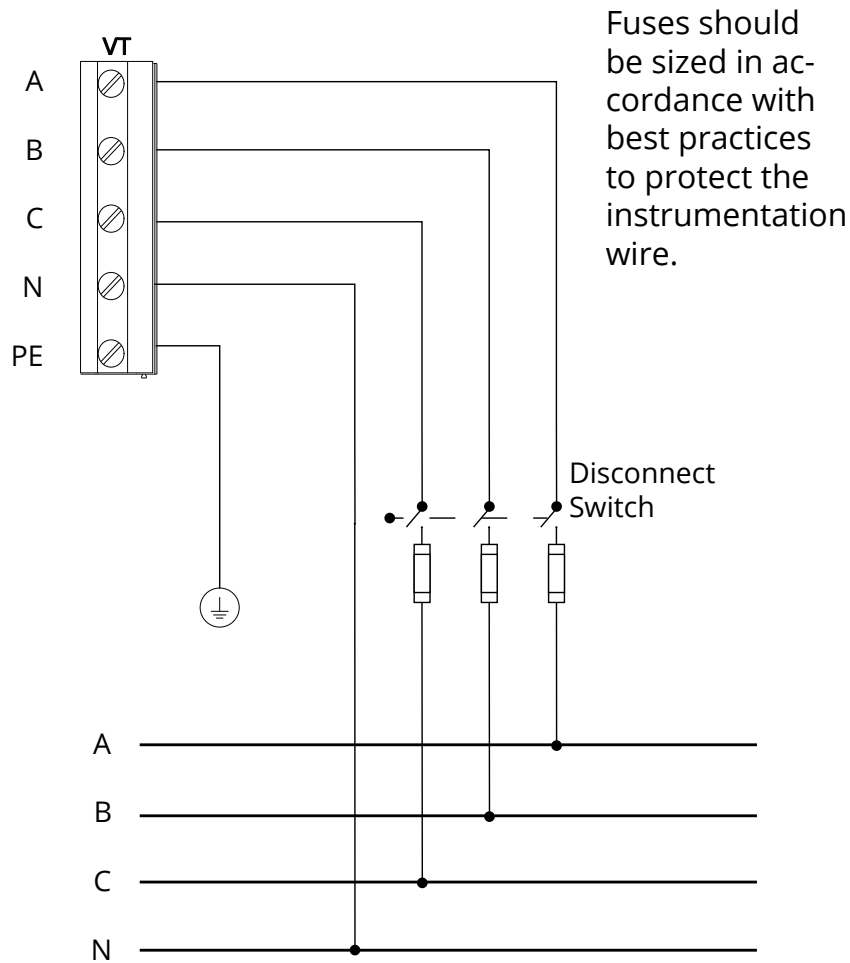

Voltage Monitoring Diagram 4: Four Wire Wye

Three Wire Delta with Potential Transformers

Voltage Connection Input - Three Wire Delta with PTs

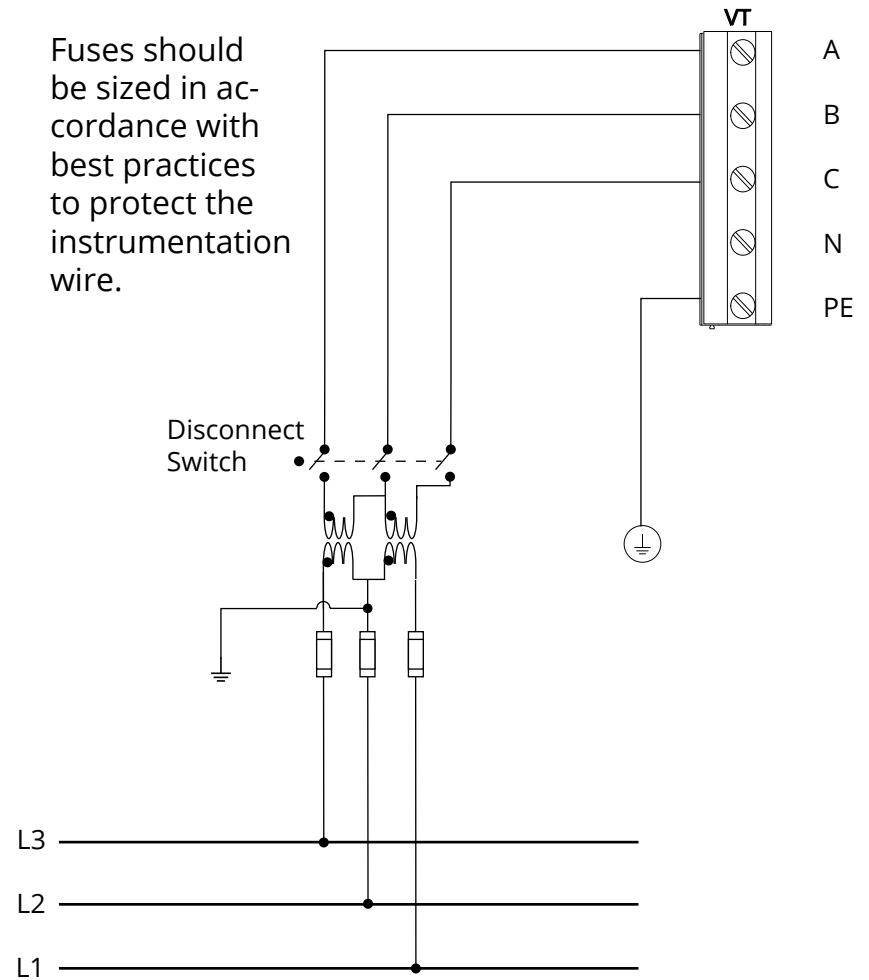

Voltage Monitoring Diagram 5: Three Wire Delta with Potential Transformers



Four Wire Wye With Potential Transformers

Voltage Connection Input - Four Wire Wye with PTs

Fuses should be sized in accordance with best practices to protect the instrumentation wire.

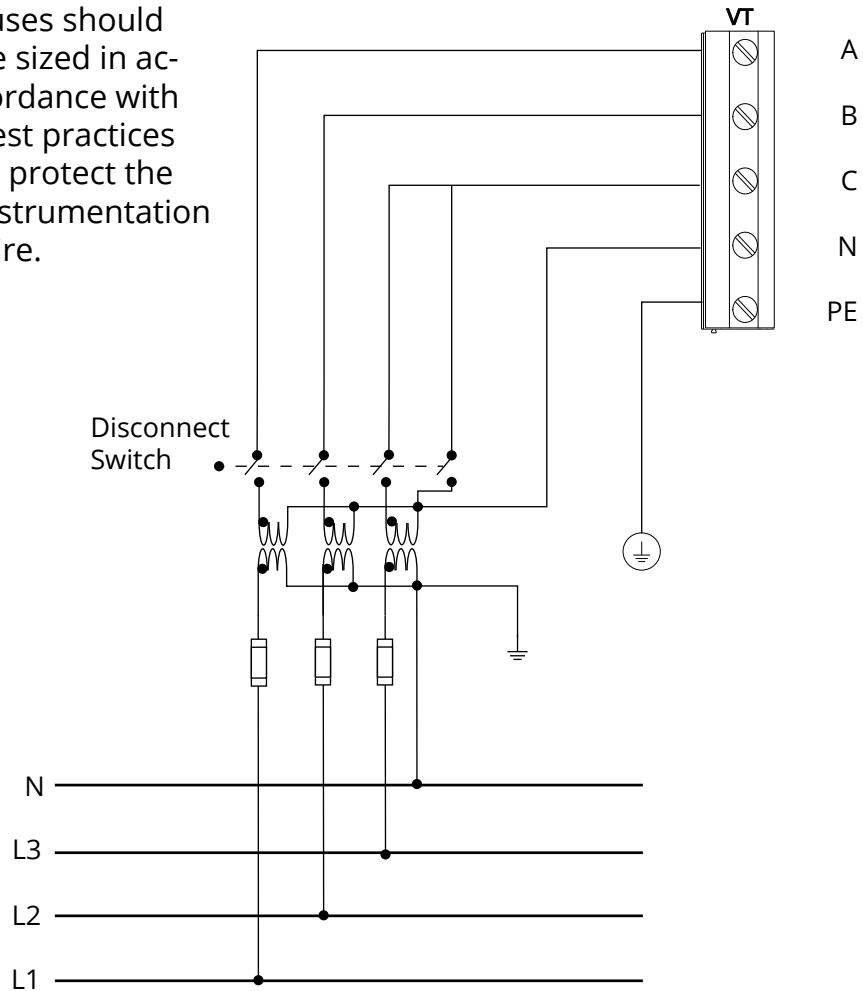

Voltage Monitoring Diagram 6: Four Wire WYE With Potential Transformers



Controls and Indicators on the PXBCM-MB

The figure to the right shows the locations of the following controls and indicators:

COM1: Separate red/green Tx/Rx LEDs

LAN: Communications LEDs:

Link:

- Green = link active
- Green blinking = link Tx/Rx

10/100:

- Amber on = speed: 100M
- Off = speed: 10M

Status: red/green bicolor LED reflects operating status of the device:

- Green 1 Hz blinking = normal operation, power supply on
- Red On = Application alarm

Com Status: red/green bicolor LED:

- Green on = DHCP
- Green off = Fixed IP
- Red on = communications reset mode

COM RST: Communications reset button: returns the PXBCM-MB to its default communications settings. To reset, hold the button down until the LED lights.

Modbus address: 2 rotary switches 01-99. Top switch "high," bottom "low"

Mode switch: the following table lists the mode switch functions.

IB150003EN

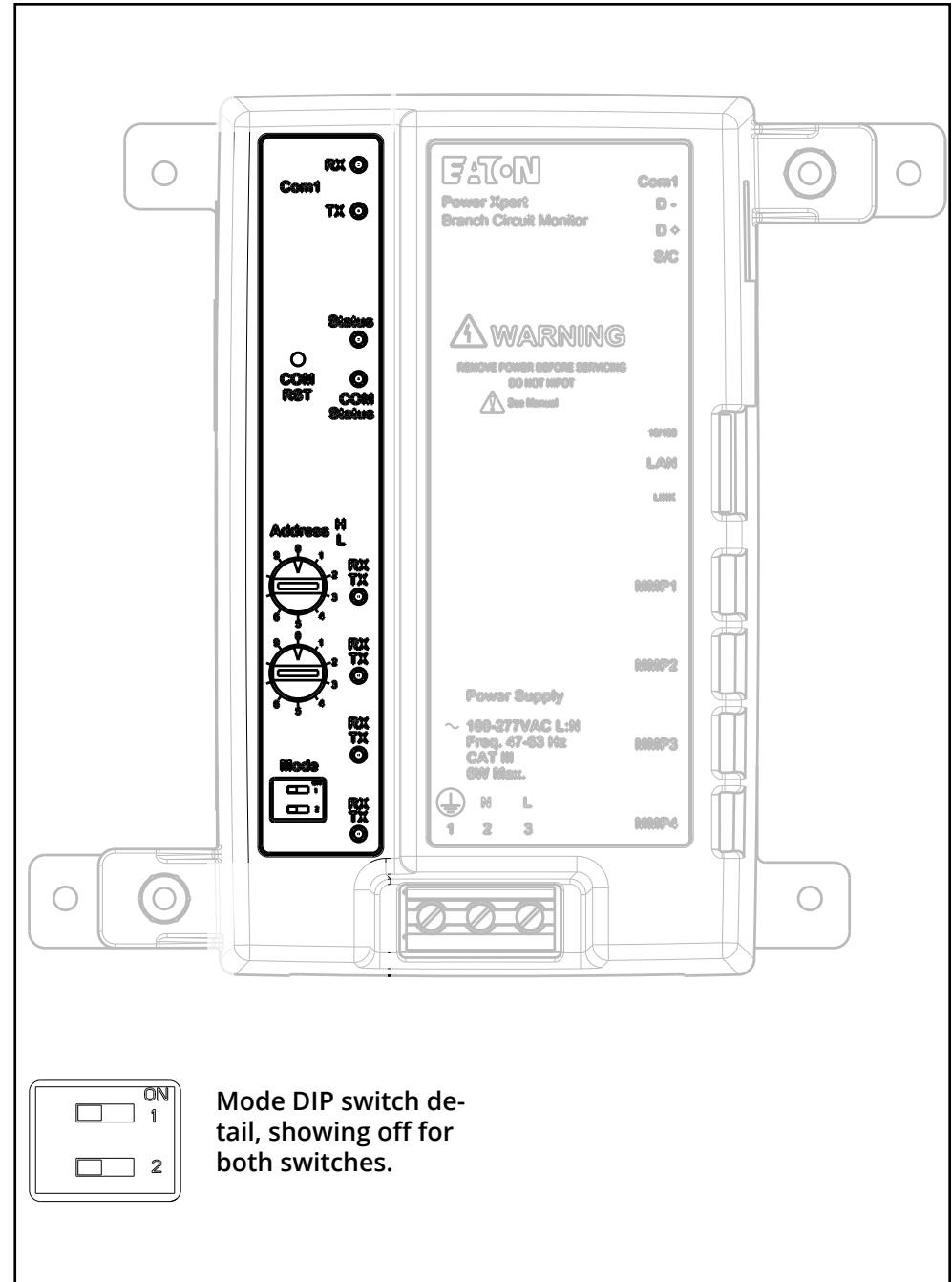



Functions	Modes			
	Normal Sw. 2 off Sw. 1 off	Secure 1 Sw. 2 off Sw. 1 on	Secure 2 Sw. 2 on Sw. 1 off	Reserved Sw. 2 on Sw. 1 on
Configuration - Web Only	Y	N	N	
Reset Data - Web Only	Y	N	N	
Reset to Factory Configuration and Reset Data - Web Only	Y	N	N	
Energy Reset - Web Only	Y	N	N	
Reset Peak Demands	Y	Y	N	
Sync Demand	Y	Y	N	
Reboot Device	Y	Y	N	
Clear Latched Alarms	Y	Y	Y	
Clear Alarm Counters	Y	Y	Y	
Reset Min/Max	Y	Y	Y	
Reset Communication Statistics	Y	Y	Y	

MMP1-4 TX/RX: One bicolor LED indicator red/green Tx/Rx per MMP port (PXBCM-CBLnn connector)

Indicators on the PXBCM-MMS

The figure to the right shows the locations of the following indicators:

- Status: Green 1 Hz blink - Normal powered up operation
- TX/RX: Separate LED indicators (red/green) showing transmit and receive activity for PXBCM-CBLnn connection to PXBCM-MB.

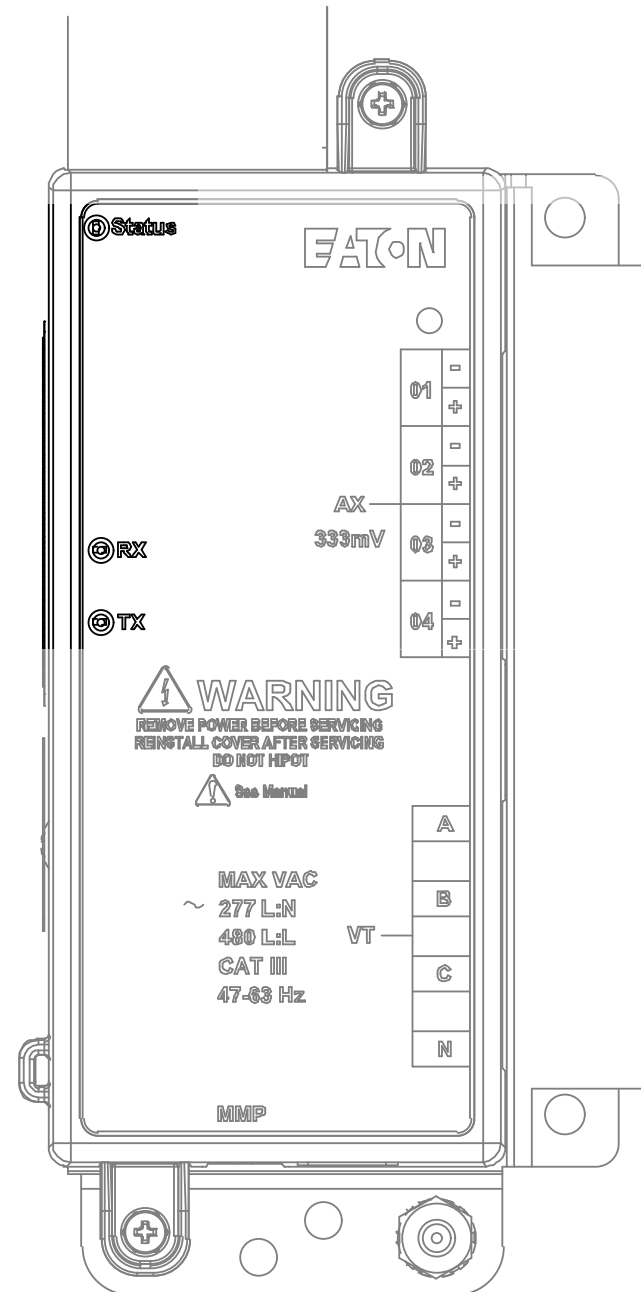



Indicators on the PXBCM-MME

The figure to the right shows the locations of the following indicators:

- MMP TX/RX: bicolor LED indicator (red/green) transmit/receive for the PXBCM-CBL $_{nn}$ connection to PXBCM-MB.
- Status: Green 1 Hz blink - Normal powered up operation.

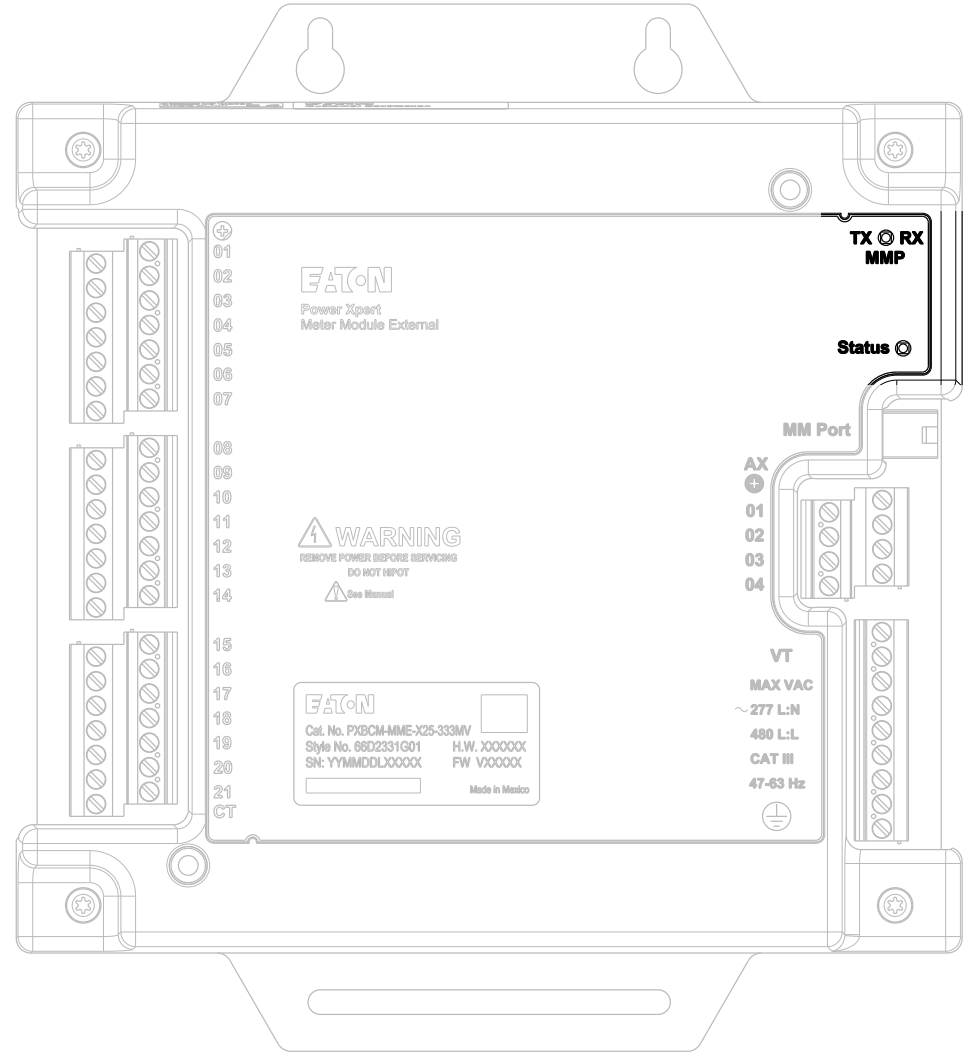



Reference: Mounting Dimensions

PXBCM-MB Mounting Dimensions

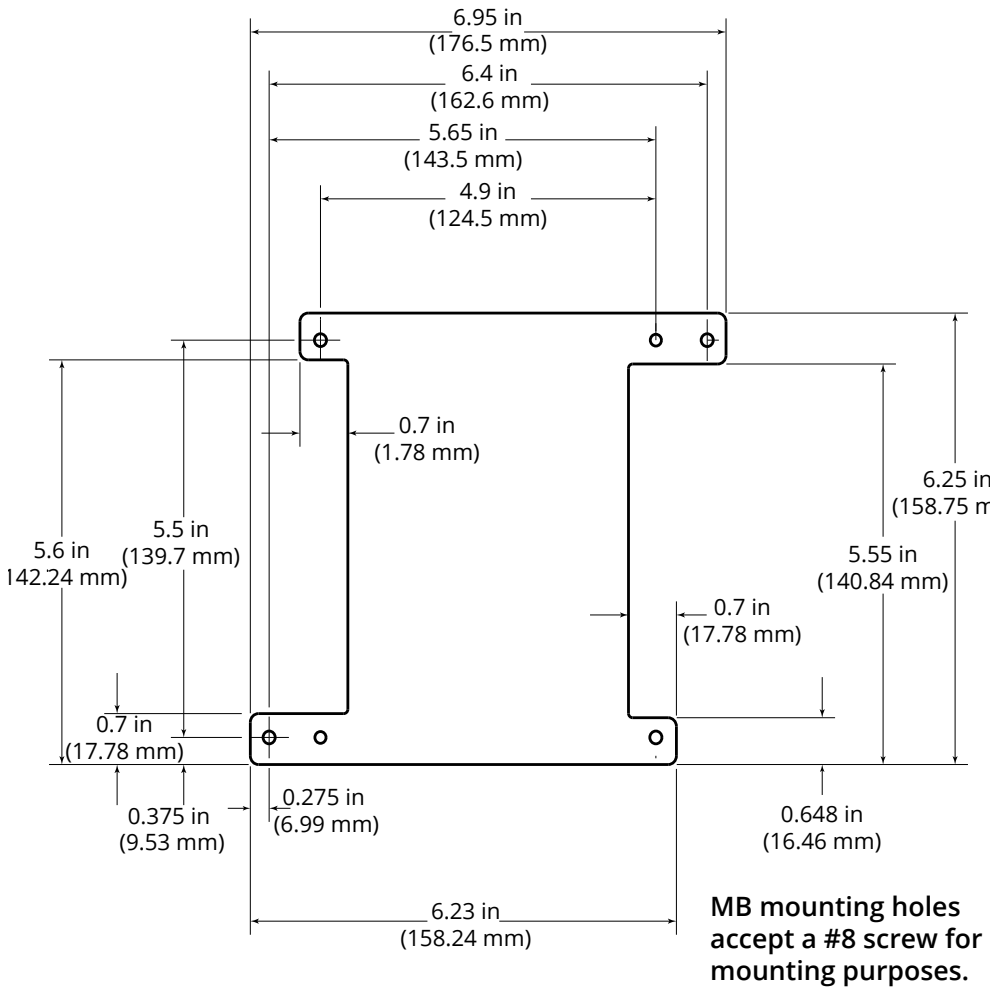

PXBCM-MMS Mounting Dimensions

While the following shows left-side units, right-side units are simply mirror images of these.

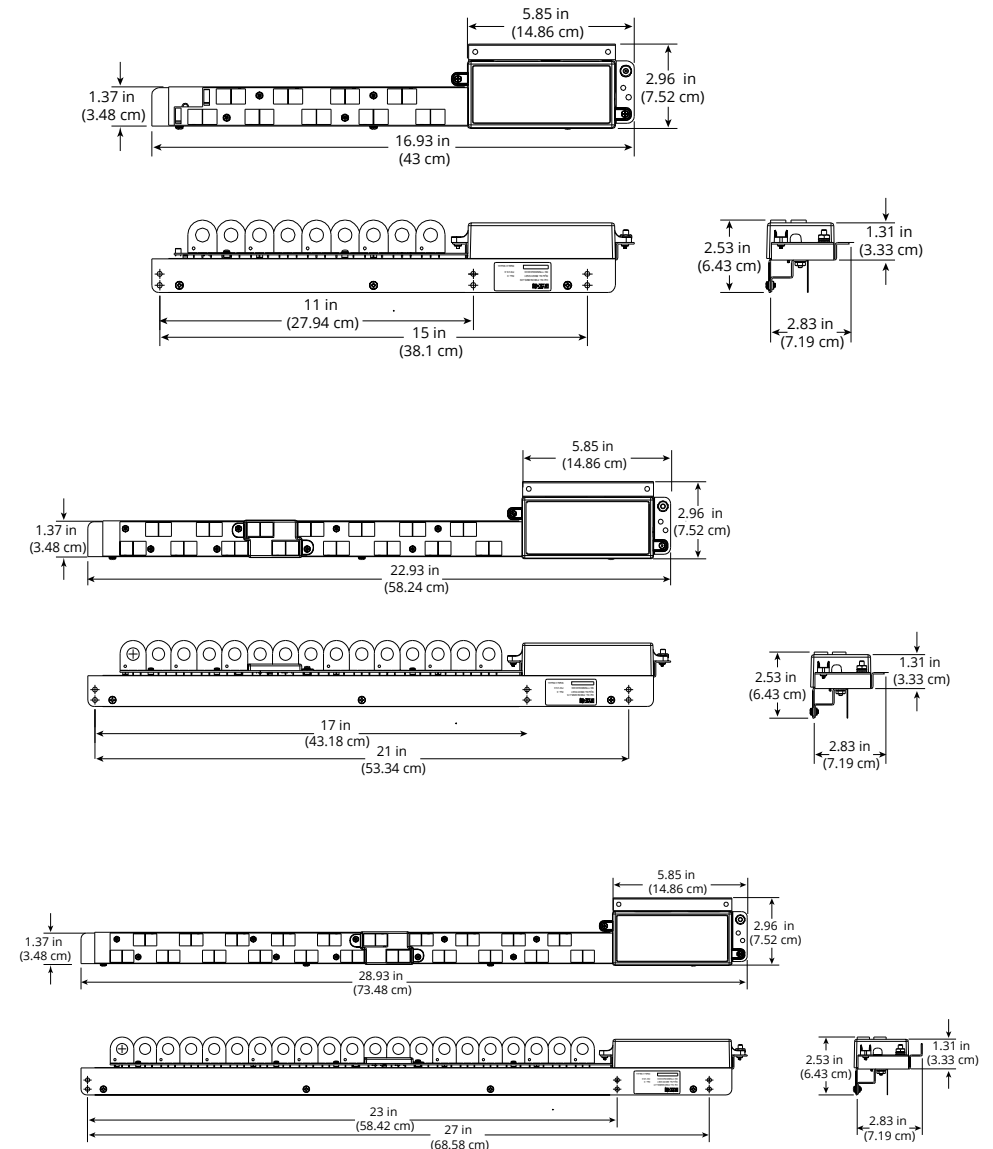



PXBCM-MME Mounting Dimensions

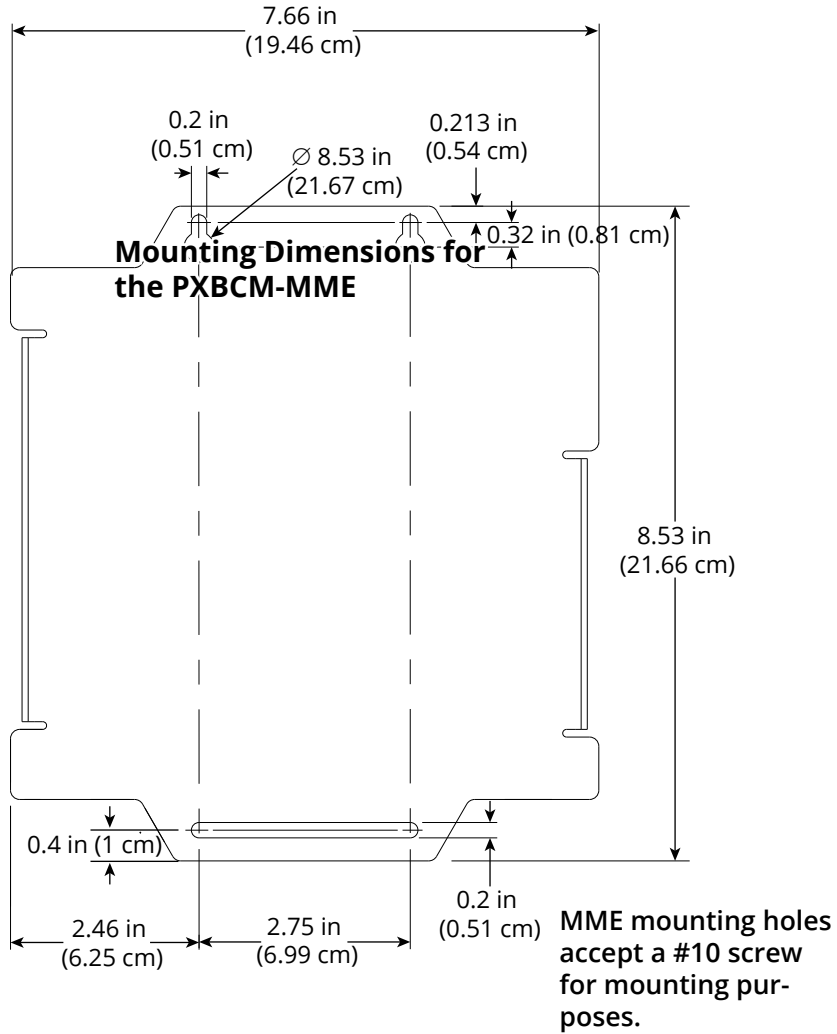



Specifications

Power Xpert Branch Circuit Monitor: General

The Power Xpert Branch Circuit Monitor (PXBCM) meter system must be mounted inside appropriate enclosure(s) that provide adequate internal environment and safety barrier.

Environmental

- Elevation: 0 – 9843 ft (0 – 3000M)
- Pollution degree: 2
- Ambient temperature range: -20°C – +70°C (-4° – +158°F)
- Storage temperature range: -40°C to +85°C (-40°F - +185°F)
- Humidity: 5% – 95% non condensing.
- Housing NEMA 1 rated
- Housing ingress protection: IP20

CE Mark

EMC (ElectroMagnetic Compatibility)

- IEC61326: EMI IEC61000-4-X level 3
- CISPR 11: Class B emissions, CISPR 22 (Ethernet) class B emissions
- FCC part 15 Class B emissions

Safety

- UL/cUL 61010-1 3rd, UL file E185559
- EN61010-1

Power Xpert Branch Circuit Monitor: Meter Base

Power Supply

- 100-277VAC L:N +/-10%, CAT III, 47-63 Hz , 6W
- Double insulated
- 320VAC Surge filter clamp L:N, L:G, N:G - **Do not high pot!**
- Provide external line fuse sized to protect wiring
- 3 position fixed terminal block 1/2/3 = PE/N/L, supporting 12 AWG (2.5mm) wire.

MMP1-4 Meter Module (MM) Port 1-4:

- 2 twisted-pairs source MM power and MB/MM communications link.
- Connector 2X2 square socket: requires mating PXBCM-MMP-CBLnn cable, maximum length 28 ft (8.53 M). Not isolated at Meter Module. Basic isolation only at Meter Base.
- MM load 1W maximum, short tolerant

COM 1 RS485 serial port

- Supports Modbus RTU 9600 to 115.2K baud (default is 115.2K baud).
- Basic isolation interface has field TVS diode clamp to ground at 300V, data lines short tolerant
- Internal 10K pull up/down data line bias, fail safe transceiver
- Cable: use low L:L capacitance, 100-120 ohm shielded cable designed for RS485 applications
- 32 slave transceivers per common RS485 cable, maximum distance 4,000 ft (1220 M) 9600-38.4K baud, 2,000 ft (610 M) 56-115.2 K baud
- 3 position removable terminal block plug D-, D+, shield/common



LAN Ethernet

- 10/100 base T/Tx
- Modbus TCP
- Web server: configuration/monitor port
- Connector: tab up, shielded/grounded RJ45
- Cable: CAT5 minimum, STP shielded twisted pair required for full EMI performance
- Cable run: maximum of 425 ft (130 M) from port
- 1KV pulse transformer isolation

User Controls/Indicators

- Mode switch: 2 position, function TBD (configuration lock +)
- Modbus address: 2 rotary switches 01-99
- Com reset button: Resets the Ethernet port. Also, allows the user to log in with default password for a short duration
- Status LED: red/green bicolor
 - Green 1 Hz blink = normal operation, power supply on
 - Red on Application Alarm TBD
- Com status LED: red/green bicolor
 - Green on/off = DHCP/Fixed IP
 - Red on = communications reset mode
- Ethernet connector LEDs: Green=link active, blink=Tx/Rx activity, amber on - speed = 100M, amber off - speed = 10M
- MMP1-4: One bicolor LED indicator red/green Tx/Rx per MMP
- Com 1: separate red/green Tx/Rx LEDs

Power Xpert Branch Circuit Monitor: Meter Module External

MMP - Meter Module Port

- 2 twisted pair sources Meter Module power from MB and MB/MM com link
- Connector 2X2 square socket: requires mating PXBCM-MMP-CBLnn cable, maximum length 28 ft (8.53 M)
- Not isolated at Meter Module, basic isolation at MB only
- MM load 1W maximum

VT - Voltage Terminal Metering

- 47 – 63 Hz., CAT III, 5 M ohm input impedance
- WYE 277VAC L:N(G) 480VL:L maximum nominal
- Floating delta, corner grounded delta, and high-impedance Wye not supported without the use of an interposing PT Potential Transformer.
- 5 Position fixed terminal block Va, Vb, Vc, Vn, PE

CT - Current Terminal - Branch Circuit Metering

- 21 total CT circuits, arranged in 3 terminal groups of 7 circuits
- Dual-tier terminal block, Back/high tier for positive input, front/lower tier for negative CT inputs
- 333mV secondary CT input to MME at maximum external CT Primary rating
 - Primary load rating determined by external CT
- External CT should provide basic Isolation between primary load cable to secondary, UL qualified to:
 - UL61010-1
 - UL2808
 - UL/ANSI C57.13



AX - Auxiliary Current Terminal - Auxiliary/Mains Metering

- 4 AX 333mV external current transformer circuits, arranged as one dual-tier terminal block
- AX ratings and circuit design identical to CT

User Interface

- Status LED - Bicolor red/green
 - Green 1 Hz blink - Normal powered up operation
 - Red - TBD
- MMP red/green bicolor: communications Tx/Rx

Power Xpert Branch Circuit Monitor: Meter Module Strip

For use in Panel boards where the MMS has been evaluated by UL as an approved accessory such as Eaton Pow-R-Line 1a, 2a, 3e

MMP - Meter Module Port

- 2 twisted-pair sources MM power from MB and MB/MM com link
- Connector 2X2 square socket: requires mating PXBCM-MMP-CBLnn cable, maximum length 28 ft (8.53 M)
- Not isolated at MM, basic isolation at MB only
- MM load 1W maximum

VT - Voltage Terminal Metering

- 47 – 63 Hz., CAT III, 5 M ohm input impedance
- Wye 277 VAC L:N 480VL:L maximum
- Floating delta, corner grounded delta, and high-impedance Wye not supported without the use of an interposing PT Potential Transformer.

- 5 Position fixed terminal block Va, Vb, Vc, Vn,
- PE - Protective Earth grounding stud at base of MMS bracket - #8 stud

Branch Circuit Current Metering - Integral mounted current transformers

- 9, 15 or 21 CTs spaced for 1" pitch
- Primary maximum rating 100A, 600V
- CT internal diameter 0.484"
- Current Input Rating: 100A
- kWh Accuracy: C12.20 0.5 Class performance

AX - Auxiliary Current Terminal - Auxiliary/Mains Metering

- Single-tier terminal block, arranged: + in four pairs AX1-4
- 333mV Secondary CT input to MMS at max external CT primary rating
 - Primary load rating determined by external CT
- External CT should provide basic isolation between primary load cable to secondary, UL qualified to:
 - UL61010-1
 - UL2808
 - UL/ANSI C57.13
- Current Input Rating : 333mV
- kWh Accuracy: ANSI C12.20 0.5 Class performance (excluding 333mV external sensors)

Indicators

- Status LED
 - Green 1 Hz blink - Normal powered up operation
- MMP com LED - separate red/green Tx/Rx



Glossary

Approved Panel Board - Application appropriate UL or NEMA approved electrical panel to enclose the PXBCM components, current sensors, and circuit breakers.

Branch Circuits - Monitored loads whose wiring is protected by circuit breakers within a panel.

Current Sensor - External current monitoring circuit. In the context of the PXBCM, the current sensor consists of a Current Transformer and burden resistor that results in a 333mV full-scale output when rated current is applied to the sensor.

CT - Current Transformer. Also, CT (Current Terminal) is labelled on a device terminal block.

Disconnect Switch - Load breaking switch or circuit breaker to safely separate equipment from line voltage for maintenance.

Enclosure - Box to safely mount and hold electrical circuits and hardware.

Main - Voltage source for one of more switchboard or panel-board circuits, commonly at the point of common coupling with an electrical utility.

Modbus RTU - RS485-based serial communications protocol with a single master and one or more Remote Terminal Unit (RTU) devices.

Modbus TCP - Ethernet-based implementation of the Modbus protocol.

Panel Board - Electrical power distribution assembly that sources power and provides over current protection to external loads. Panel boards are typically covered by UL67 for safety purposes. The PXBCM components are considered panel board accessories and must be approved for use within specific vendor panel board models.

Pollution Degree - Level of environmental exposure for expected applications.

PT - Potential Transformer (aka VT - Voltage Transformer).

RS485 - Serial communication hardware physical layer interface using differential transceivers on a single twisted wire pair and common.

Single-Phase - The voltage source is from one AC supply.

Single-Phase, Three Wire - The voltage source is split at a transformer so that two AC wires have opposite polarity (180 degrees out of phase with each other) and one neutral wire is common.

Single-Phase, Two Wire - The voltage source has one AC wire and one neutral.

Three-Phase - A voltage source with three AC wires that are out of phase with respect to each other

Three-Phase Four Wire Wye - A voltage source with a common neutral and three AC wires whose phases are 120 degrees apart with respect to each other.

Three-Phase Three Wire Delta - A voltage source with three AC wires whose phases are 120 degrees apart with respect to each other but without a wired neutral (Note: The PXBCM does not support a floating delta or a corner-grounded delta. The PXBCM specifically supports a delta circuit that comes from a Wye secondary transformer where the neutral is grounded but not made available to load circuits).

Three-Phase Center Tapped Delta - (aka high-leg delta, hot-leg delta, wild-leg delta) Three-phase circuit with a neutral that splits one of three line-to-line voltages. As a result two of three line-to-neutral voltages are of opposite polarity and a third voltage is $\sqrt{3}$ larger and 90 degrees out of phase with respect to the other two line-to-neutral voltages. (Note: The PXBCM specifically supports the circuit where phase B is the larger voltage.)



Virtual Meter – One, two, or three current sensors selected and configured as an energy meter. In the context of the PXBCM, all selected sensors must be from the same meter module (MMS/MME) for a given virtual meter.



Legal Statement

Power Xpert® is a registered trademark of Eaton Corporation.

DISCLAIMER OF WARRANTIES AND LIMITATION OF LIABILITY

This user manual is published solely for information purposes and should not be considered all-inclusive. If further information is required, you should consult an authorized Eaton sales representative. The sale of the product shown in this literature is subject to the terms and conditions outlined in appropriate Eaton selling policies or other contractual agreement between the parties. This literature is not intended to and does not enlarge or add to any such contract. The sole source governing the rights and remedies of any purchaser of this equipment is the contract between the purchaser and Eaton.

NO WARRANTIES, EXPRESSED OR IMPLIED, INCLUDING WARRANTIES OF FITNESS FOR A PARTICULAR PURPOSE OR MERCHANTABILITY, OR WARRANTIES ARISING FROM COURSE OF DEALING OR USAGE OF TRADE, ARE MADE REGARDING THE INFORMATION, RECOMMENDATIONS, AND DESCRIPTIONS CONTAINED HEREIN.

In no event will Eaton be responsible to the purchaser or user in contract, in tort (including negligence), strict liability or otherwise for any special, indirect, incidental or consequential damage or loss whatsoever, including but not limited to damage or loss of use of equipment, plant or power system, cost of capital, loss of power, additional expenses in the use of existing power facilities, or claims against the purchaser or user by its customers resulting from the use of the information, recommendations and description contained herein.

