

CLEAN TRAY™ STAINLESS STEEL CABLE TRAY, TYPE 1



INDUSTRY STANDARDS

UL Classified; File No. E263414
 This product is classified as to its suitability as an equipment grounding conductor only.

NEMA/EEMAC Type 1

APPLICATION

The CLEAN TRAY™ Stainless Steel Cable Tray is designed to protect rated cabling in applications that require frequent washdown. A variety of sloped-top fittings with front, inside or outside cover options allows for highly-customized runs using standard catalog product and supports directional control of washdown effluent.

FEATURES

- Adjustable dividers
- Tops and sides can completely open
- Flat cover and 20-degree sloped cover models available
- Perforated fittings and straight sections
- Elbows contain three cover options: front, inside and outside
- Connecting hardware is included with each model
- Quarter-turn latches

SPECIFICATIONS

- 18 gauge stainless steel

FINISH

Smooth brushed finish

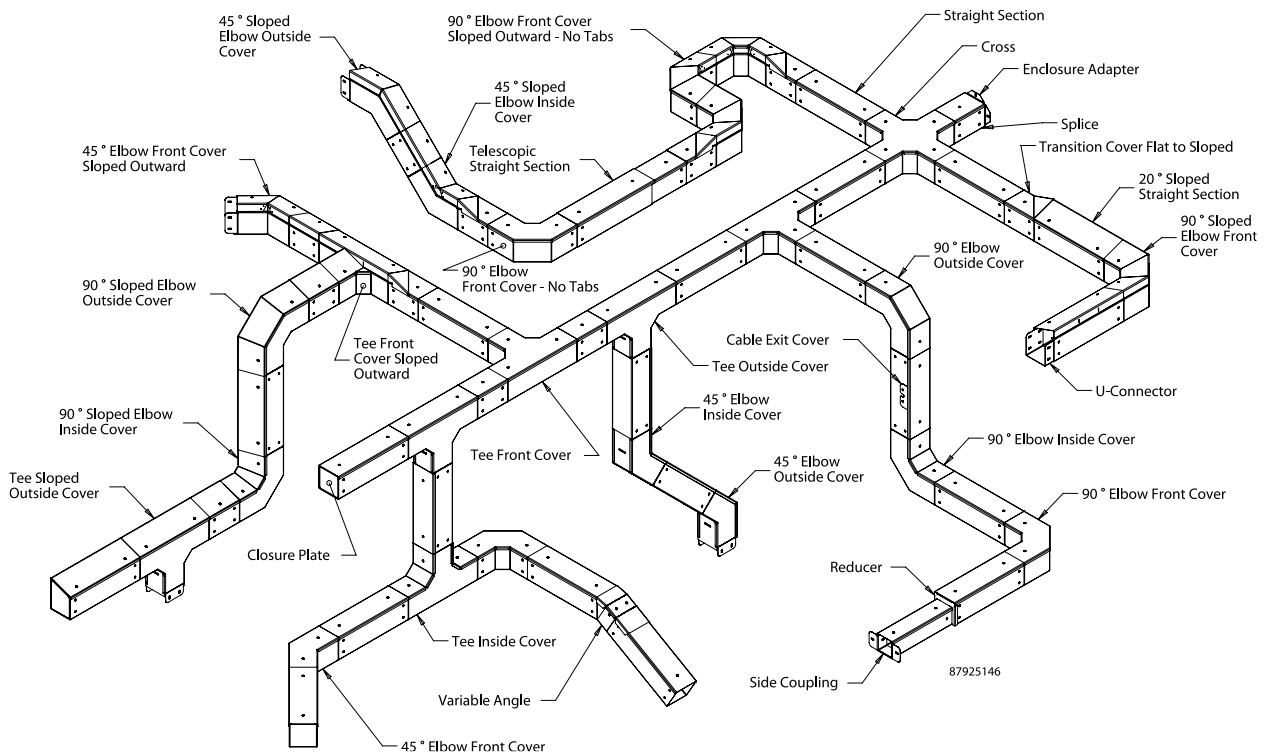

STRAIGHT SECTION



Straight sections are available in 10-ft. lengths with or without perforations. Available with a 20-degree sloped cover in some sizes. One U-connector and hardware is supplied with each straight section.

BULLETIN: F23

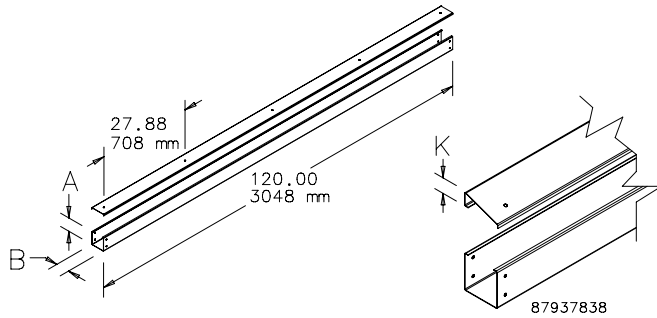

Catalog Number	AxB in./mm	Description	K in./mm
CT22120SS	2.00 x 2.00 51 x 51	Standard	—
CT33120SS	3.00 x 3.00 76 x 76	Standard	—
CT44120SS	4.00 x 4.00 102 x 102	Standard	—
CT46120SS	4.00 x 6.00 102 x 152	Standard	—
CT66120SS	6.00 x 6.00 152 x 152	Standard	—
CT22P120SS	2.00 x 2.00 51 x 51	Perforated	—
CT33P120SS	3.00 x 3.00 76 x 76	Perforated	—
CT44P120SS	4.00 x 4.00 102 x 102	Perforated	—
CT46P120SS	4.00 x 6.00 102 x 152	Perforated	—
CT66P120SS	6.00 x 6.00 152 x 152	Perforated	—
CTS33120SS	3.00 x 3.00 76 x 76	Sloped Top	1.06 24
CTS44120SS	4.00 x 4.00 102 x 102	Sloped Top	1.42 36
CTS46120SS	4.00 x 6.00 102 x 152	Sloped Top	2.16 55
CTS66120SS	6.00 x 6.00 152 x 152	Sloped Top	2.16 55
CTS33P120SS	3.00 x 3.00 76 x 76	Sloped Top Perforated	1.06 27
CTS44P120SS	4.00 x 4.00 102 x 102	Sloped Top Perforated	1.42 36
CTS46P120SS	4.00 x 6.00 102 x 152	Sloped Top Perforated	2.16 55
CTS66P120SS	6.00 x 6.00 152 x 152	Sloped Top Perforated	2.16 55

DIVIDER STRAIGHT SECTION

Used to divide one straight section into two sections.

BULLETIN: F23

Catalog Number	AxB in./mm	Fits Cable Tray Size in./mm	L in./mm
CT33DSS	3.00 x 3.00 76 x 76	4.00 x 4.00 102 x 102	2.13 54
CT44DSS	4.00 x 4.00 102 x 102	4.00 x 6.00 102 x 152	3.13 79
CT66DSS	6.00 x 6.00 152 x 152	6.00 x 6.00 152 x 152	5.13 130

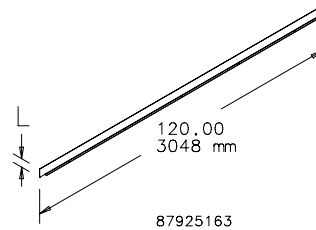

TELESCOPIC STRAIGHT SECTION



Adjusts from 18.74 in. to 30.61 in.

BULLETIN: F23

Catalog Number	AxB in.	AxB mm
CT22TSS	2.00 x 2.00	51 x 51
CT33TSS	3.00 x 3.00	76 x 76
CT44TSS	4.00 x 4.00	102 x 102
CT46TSS	4.00 x 6.00	102 x 152
CT66TSS	6.00 x 6.00	152 x 152

