

**SPECTRACOO<sup>TM</sup>**  
AIR CONDITIONER  
N28 MODEL

# INSTRUCTION MANUAL

DESIGN WITH CONFIDENCE<sup>®</sup>

# TABLE OF CONTENTS

RECEIVING THE AIR CONDITIONER.....	3
HANDLING AND TESTING THE AIR CONDITIONER.....	3
HOW TO READ MODEL NUMBERS.....	3
TECHNICAL INFORMATION.....	4
Sequence of Operation.....	4
Heating.....	4
Cooling.....	4
Standard and Optional Component Operation.....	4
Thermostat.....	4
Remote Access Control (optional).....	4
Head Pressure Control (optional).....	4
200V to 230V Transformer (N280425GXXX only).....	4
115V/230V to 10V Transformer (optional).....	4
115V/230V to 24V Transformer and Relay (optional).....	4
For cooling (75-100 F range).....	4
For heating (55-65 F range).....	4
Schematics and Wiring Diagrams for Thermostat Control.....	5
Generic 1-Phase Schematic Except 230V 50hz (actual unit options may vary).....	5
Generic 230V 50hz 1-Phase Schematic (actual unit options may vary).....	5
Generic 3-Phase Schematic (actual unit options may vary).....	6
Generic 1-Phase Wire Diagram Except 230V 50hz (actual unit options may vary).....	7
Generic 230V 50hz 1-Phase Wire Diagram (actual unit options may vary).....	8
Generic 3-Phase Wire Diagram (actual unit options may vary).....	9
DIMENSIONAL DRAWING.....	10
With Thermostats.....	10
INSTALLATION INSTRUCTIONS.....	11
REMOTE ACCESS CONTROL (optional).....	12
INTRODUCTION.....	12
ENERGIZING THE CONTROLLER.....	12
CONTROL STATUS INDICATION.....	12
DISPLAYING AND CHANGING PROGRAM VARIABLES.....	13
OPERATING PARAMETERS.....	13
ALARM PARAMETERS.....	13
DISPLAYING TEMPERATURE SENSOR #2.....	13
COMPRESSOR RESTART TIME DELAY.....	13
ALARM OUTPUT CONTACT.....	13
ALARM INPUT CONNECTION.....	14
ALARM CONDITION DISPLAY.....	14
AIR CONDITIONER UNIT COMMUNICATION FEATURES.....	14
USB Communication.....	14
Ethernet Communication.....	14
Software and MIB File Downloads.....	15
Using the PC Interface Tool.....	15
USB COMMUNICATION MODE.....	15
Viewing Air Conditioner Unit Values.....	15
Changing Air Conditioner Unit Values.....	15
Viewing and Changing Ethernet Information.....	15
ETHERNET COMMUNICATION MODE.....	16
Viewing Air Conditioner Unit Values.....	16
Changing Air Conditioner Unit Values.....	16
Viewing and Changing Ethernet Information.....	16
Alarm Log Accessible with SNMP.....	16
Remote Access Control Pin-out.....	17
Schematics and Wiring Diagrams for Remote Access Control.....	18
Generic 1-Phase Schematic Except 230V 50hz (actual unit options may vary).....	18
Generic 230V 50hz 1-Phase Schematic (actual unit options may vary).....	18
Generic 1-Phase Wire Diagram for Remote Access Control (actual unit options may vary).....	19
230V 50hz 1-Phase Wire Diagram for Remote Access Control (actual unit options may vary).....	20
DIMENSIONAL DRAWING.....	21
With Remote Access Control.....	21
INSTALLATION INSTRUCTIONS WITH REMOTE ACCESS CONTROL.....	22
MAINTENANCE.....	23
Compressor.....	23
Inlet Air Filter.....	23
How To Remove, Clean or Install a New Inlet Air Filter.....	23
Condenser and Evaporator Air Movers.....	24
Refrigerant Loss.....	24
Refrigerant Properties Chart (R134a).....	24
Unit Characteristics.....	25
Functional Data.....	25
SERVICE DATA.....	26
Components List.....	26
N28-0416-GXXX Pressure Tables.....	28
N28-0426-GXXX Pressure Tables.....	29
TROUBLE SHOOTING.....	30
Basic Air Conditioning Trouble Shooting Check List - Thermostat Version.....	30
Symptoms and Possible Causes - Thermostat Version.....	31
Basic Air Conditioning Trouble Shooting Check List - Remote Access Control Version.....	32
Symptoms and Possible Causes - Remote Access Control Version.....	33
WARRANTY.....	34
RETURN AND REPAIR POLICY.....	34
LIMITATION OF LIABILITY.....	35

## RECEIVING THE AIR CONDITIONER

Inspect the air conditioner. Check for concealed damage that may have occurred during shipment. Look for dents, scratches, loose assemblies, evidence of oil, etc. Damage evident upon receipt should be noted on the freight bill. Damage should be brought to the attention of the delivering carrier -- NOT to Pentair Equipment Protection -- within 15 days of delivery. Save the carton and packing material and request an inspection. Then file a claim with the delivering carrier.

Pentair Equipment Protection cannot accept responsibility for freight damages; however, we will assist you in any way possible.

 <b>CAUTION</b>
Do not attempt to operate the air conditioner while it is horizontal or on its side, back or front. The refrigeration compressor is filled with lubricating oil. This will cause permanent damage to the air conditioner and also voids the warranty.

## HANDLING AND TESTING THE AIR CONDITIONER

If the air conditioner has been in a horizontal position, be certain it is placed in an upright, vertical or mounting position for a minimum of five (5) minutes before operating.

### TEST FOR FUNCTIONALITY BEFORE MOUNTING THE AIR CONDITIONER TO THE ENCLOSURE.

Refer to the nameplate for proper electrical current requirements, and then wire the unit to a properly grounded power supply using copper conductors only. Power supply wiring should be restrained after field installation to ensure no contact with internal fan. Minimum circuit ampacity should be at least 125% of the amperage shown on the unit nameplate. No other equipment should be connected to this circuit to prevent overloading

Immediately after applying power, the evaporator blower (enclosure air) should start running. Operate the air conditioner with the compressor running for five (5) to ten (10) minutes. You will need to set the cooling thermostat or controller setpoint below the ambient temperature to operate the compressor.

Condenser air temperatures should be warmer than normal room temperatures within a few minutes after the condenser impellers start.

See Sequence of Operation on page 4 for specifics on how the unit operates when powered up.

## HOW TO READ MODEL NUMBERS

N28	04	2	6	G150
1	2	3	4	5

1. Identifies the type/family of air conditioner and the approximate height (i.e. G28 = Global family about 28 inch high).
2. This is the air conditioner's listed capacity in BTU/Hr. at rated conditions. (i.e. 06=6,000 BTU/Hr. at 131/131 F)
3. 1 = 115 Volt, 2 = 230 Volt, 4 = 460 Volt.
4. 6 = 50/60 Hz or 60 Hz only.
5. Unique set of numbers for each air conditioner which identifies the accessories on a model.

# TECHNICAL INFORMATION

## SEQUENCE OF OPERATION

The air conditioner comes standard with two internally mounted thermostats or remote access control. There are two modes of operation; heating and cooling. During heating and cooling modes the evaporator fan will be running.

### HEATING

When the enclosure temperature is below the heating thermostat setpoint, power is applied to the heaters. When the enclosure temperature is 10 degrees above the setpoint the heater is powered off.

### COOLING

When the enclosure temperature is above the cooling thermostat setpoint, power is applied through the thermostat. The compressor is then energized either directly or through a contactor if unit requires one. The condenser impellers will start immediately if the unit is not equipped with an optional head pressure control switch. If the unit is equipped with an optional head pressure control switch, the condenser impellers will start once the refrigerant pressure reaches the setting of the switch. Component specific information is listed below.

Operating the air conditioner below the minimum ambient temperature or above the maximum ambient temperatures indicated on the nameplate voids all warranties. DO NOT set the enclosure thermostat to a temperature lower than 70 F. Doing so can increase the likelihood of frost buildup on the evaporator coil.

The moisture that the enclosure air can contain is limited. If moisture flows from the drain tube continuously this can only mean that ambient air is entering the enclosure. Be aware that frequent opening of the enclosure's door admits humid air that the air conditioner must then dehumidify.

## STANDARD AND OPTIONAL COMPONENT OPERATION

### THERMOSTAT

The standard G28 air conditioner uses our standard 10-1061-16 thermostat. The thermostat setpoint equals the temperature that the air conditioner turns off. The thermostat has a 10 F differential from setpoint until it calls for cooling or heating. An example of operation is shown below.

#### FOR COOLING (75-100 F RANGE):

- Thermostat setpoint = 80 F
- Cooling turns on at 90 F
- Cooling turns off at 80 F

#### FOR HEATING (55-65 F RANGE):

- Thermostat setpoint = 55 F
- Heating turns on at 55 F
- Heating turns off at 65 F

**NOTE: For testing purposes only, the thermostat stop screw may be removed (on units so equipped) to allow settings below 70 F. After testing, replace the stop screw and verify that the thermostat cannot be set below 70 F. Extended operation below 70 F can cause coil freeze ups resulting in reduced load and/or unit damage.**

### REMOTE ACCESS CONTROL (OPTIONAL)

See REMOTE ACCESS CONTROL (optional) on page 12

### HEAD PRESSURE CONTROL (OPTIONAL)

Unit is set at the factory, no adjustment necessary.

At a saturated condenser temperature of 82 F (95 psig), the condenser fans will power off. At a saturated condenser temperature of 105 F (165 psig), the condenser fans will power on.

### 200V TO 230V TRANSFORMER (N280425GXXX ONLY)

The 230V from this transformer powers the compressor only.

### 115V/230V TO 10V TRANSFORMER (OPTIONAL)

This transformer powers the thermal display on thermostat controlled units only.

### 115V/230V TO 24V TRANSFORMER AND RELAY (OPTIONAL)

This transformer and relay are used to start/stop the unit thru a customer supplied, remote mounted door switch on thermostat controlled units only.

# SCHEMATICS AND WIRING DIAGRAMS FOR THERMOSTAT CONTROL

## GENERIC 1-PHASE SCHEMATIC EXCEPT 230V 50HZ (ACTUAL UNIT OPTIONS MAY VARY)

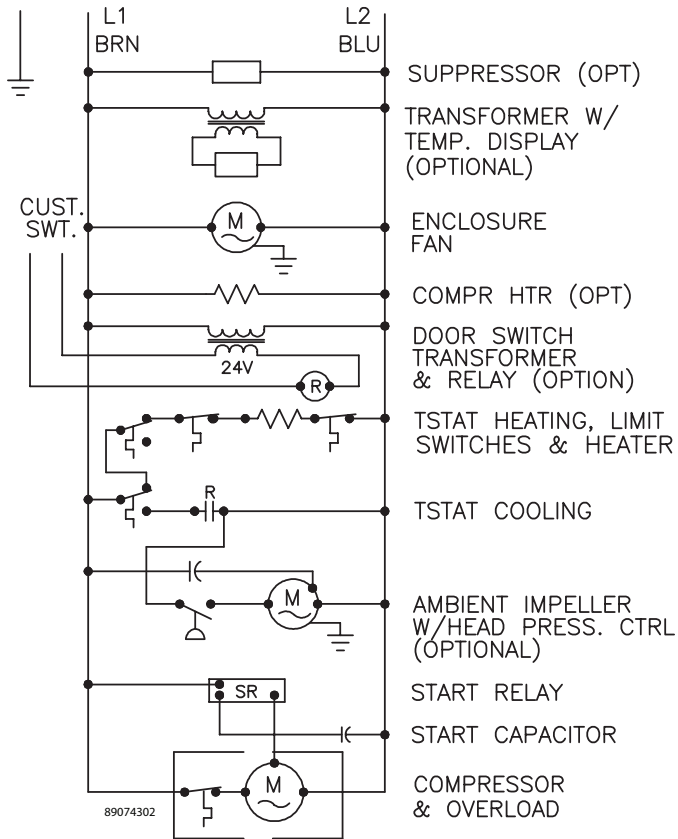

## GENERIC 230V 50HZ 1-PHASE SCHEMATIC (ACTUAL UNIT OPTIONS MAY VARY)

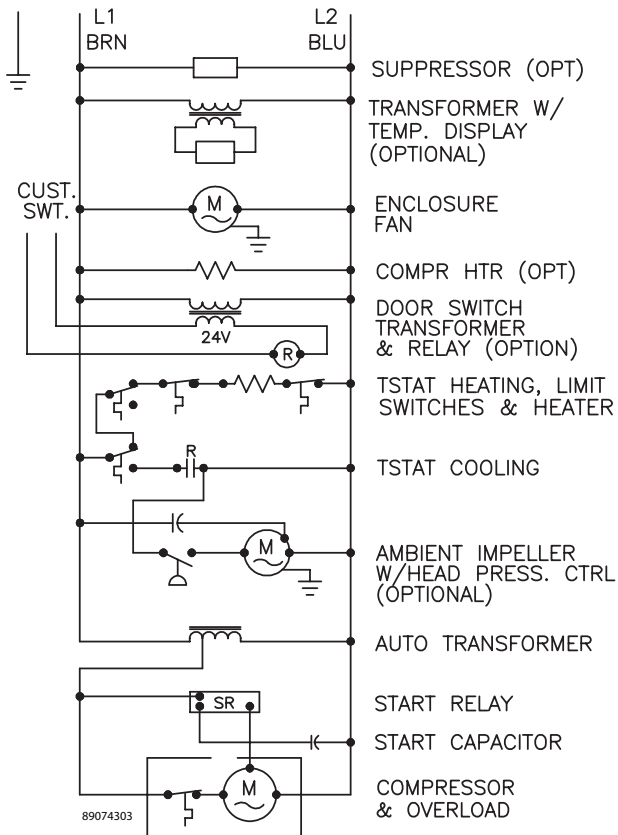

**GENERIC 3-PHASE SCHEMATIC (ACTUAL UNIT OPTIONS MAY VARY)**

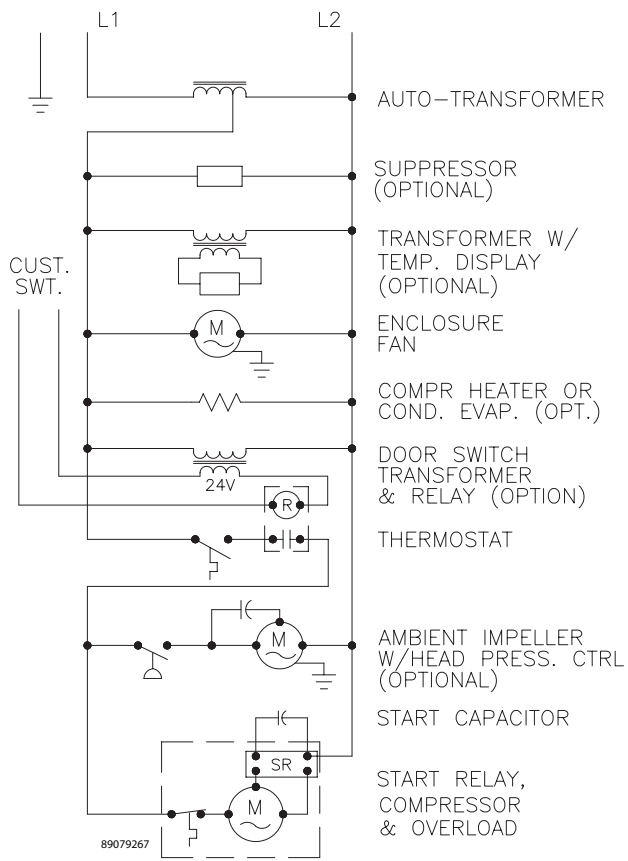

# GENERIC 1-PHASE WIRE DIAGRAM EXCEPT 230V 50HZ (ACTUAL UNIT OPTIONS MAY VARY)

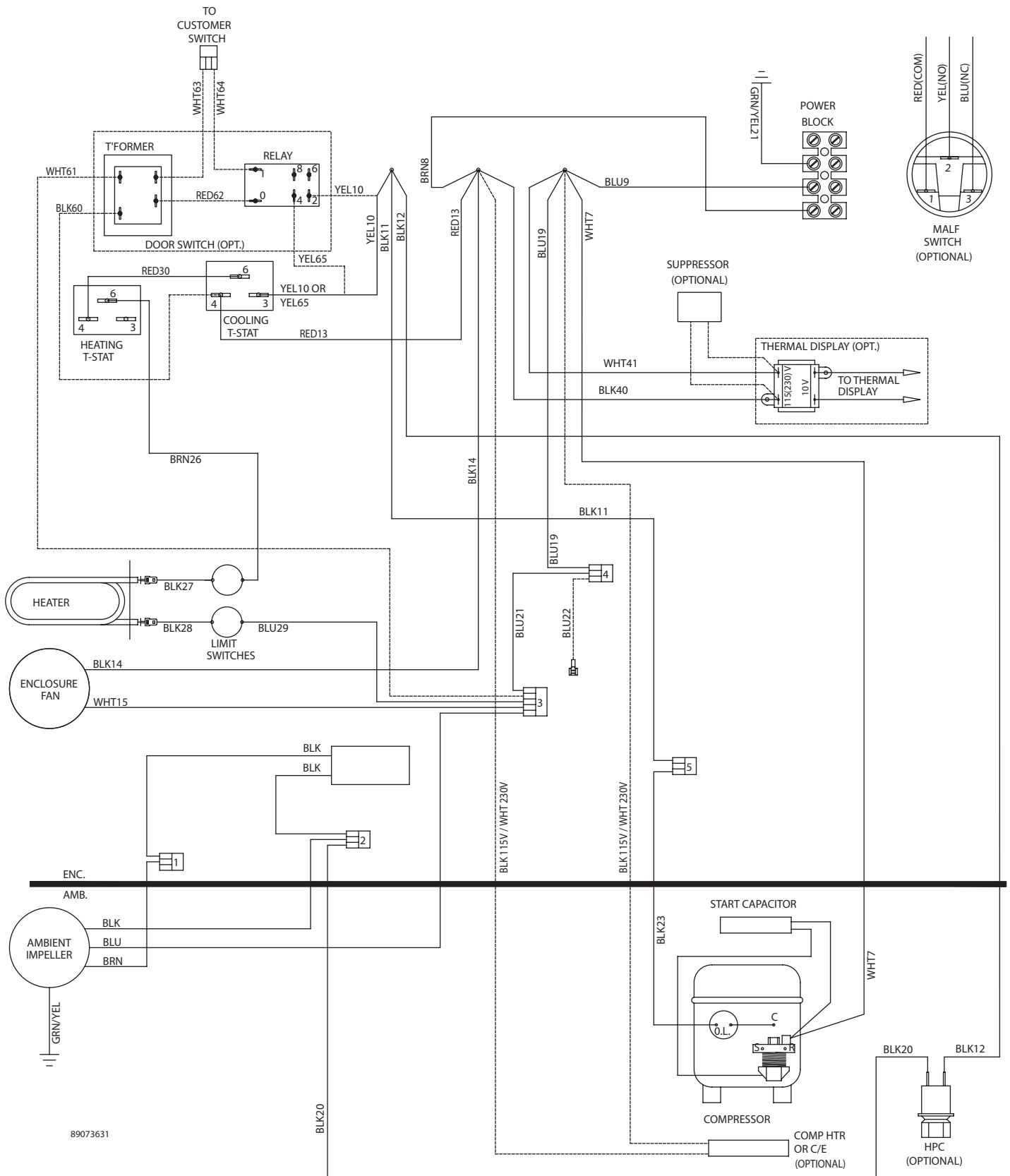

89073631

**GENERIC 230V 50HZ 1-PHASE WIRE DIAGRAM (ACTUAL UNIT OPTIONS MAY VARY)**

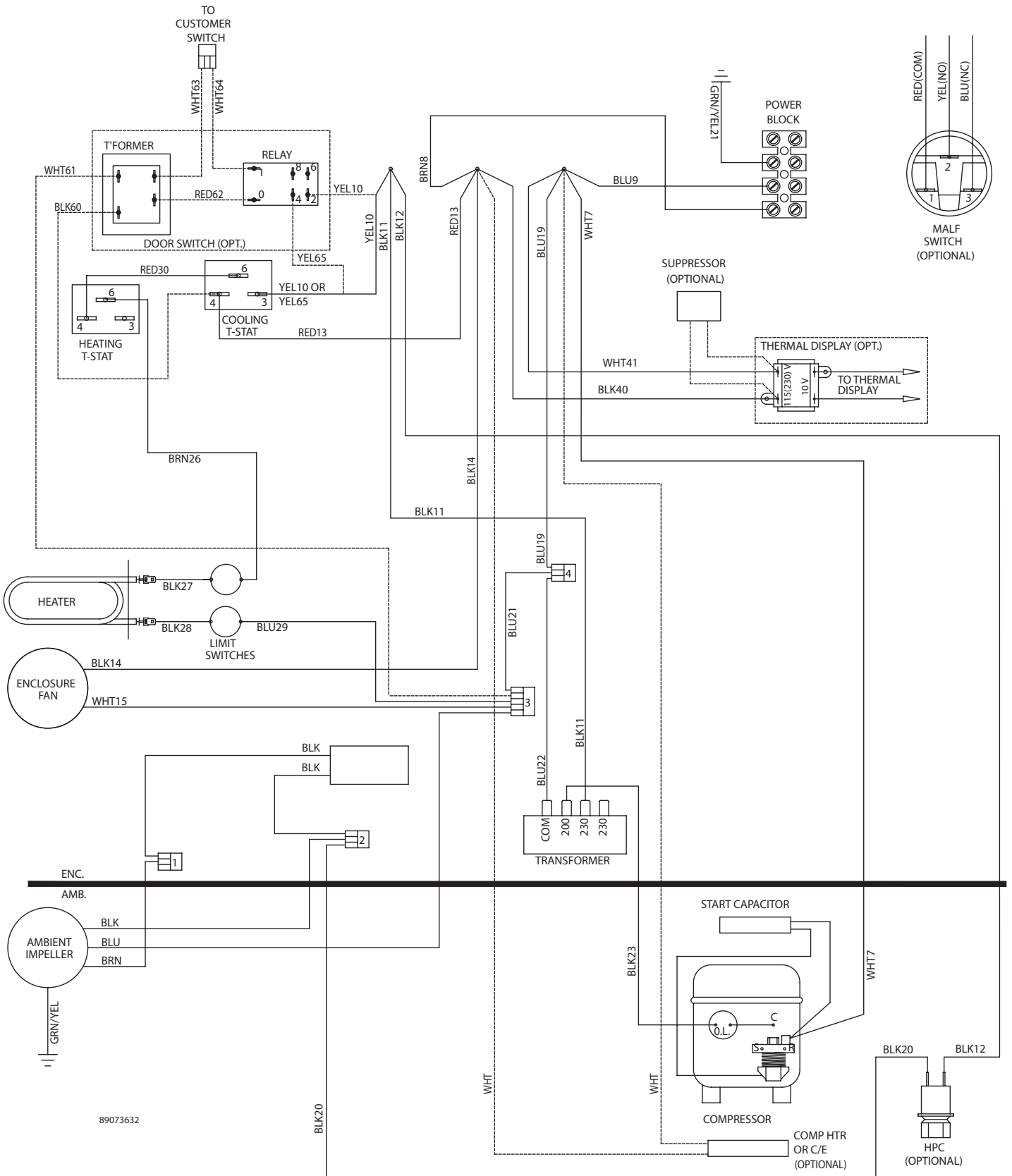



**GENERIC 3-PHASE WIRE DIAGRAM (ACTUAL UNIT OPTIONS MAY VARY)**

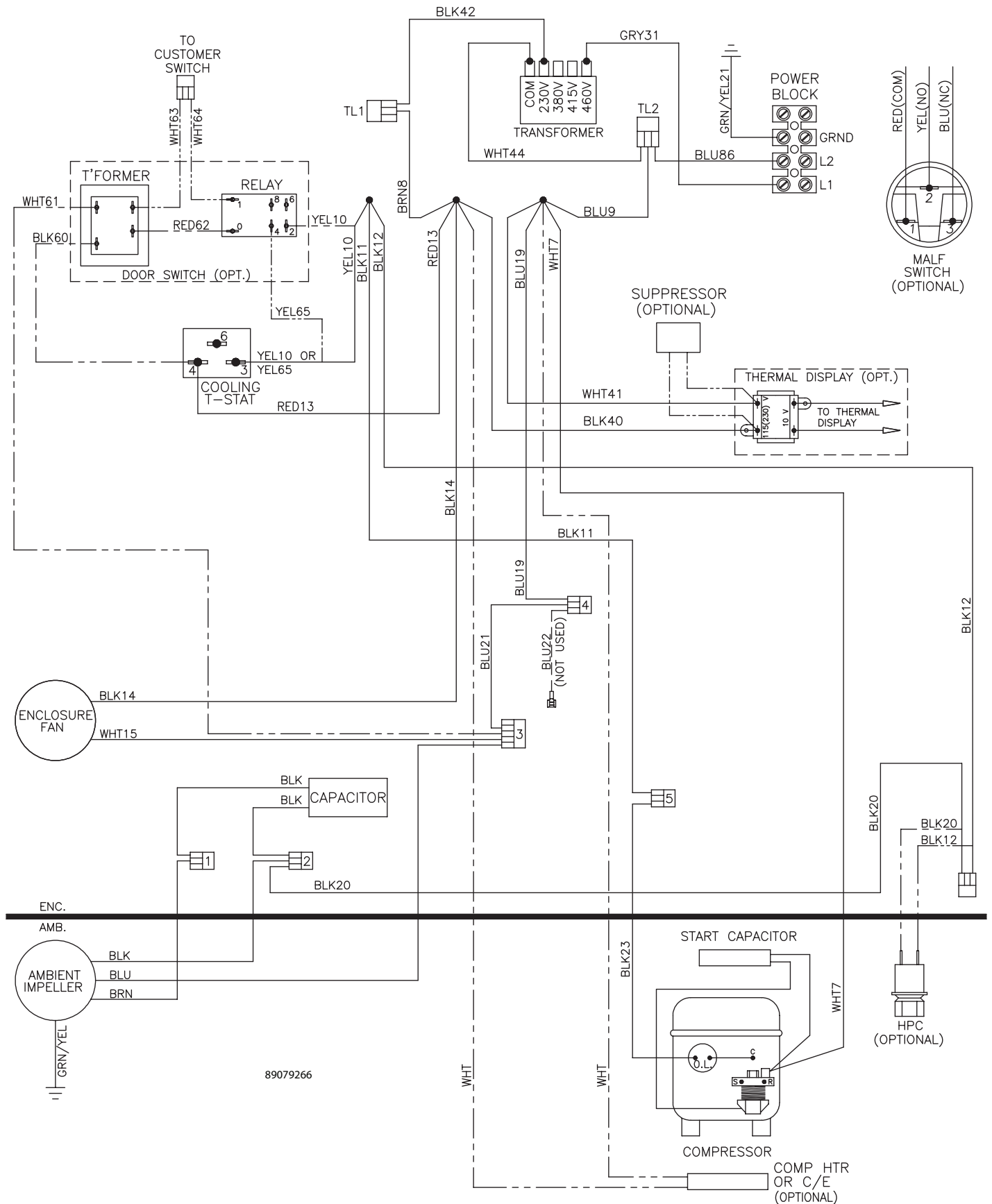

89079266

# DIMENSIONAL DRAWING

## WITH THERMOSTATS

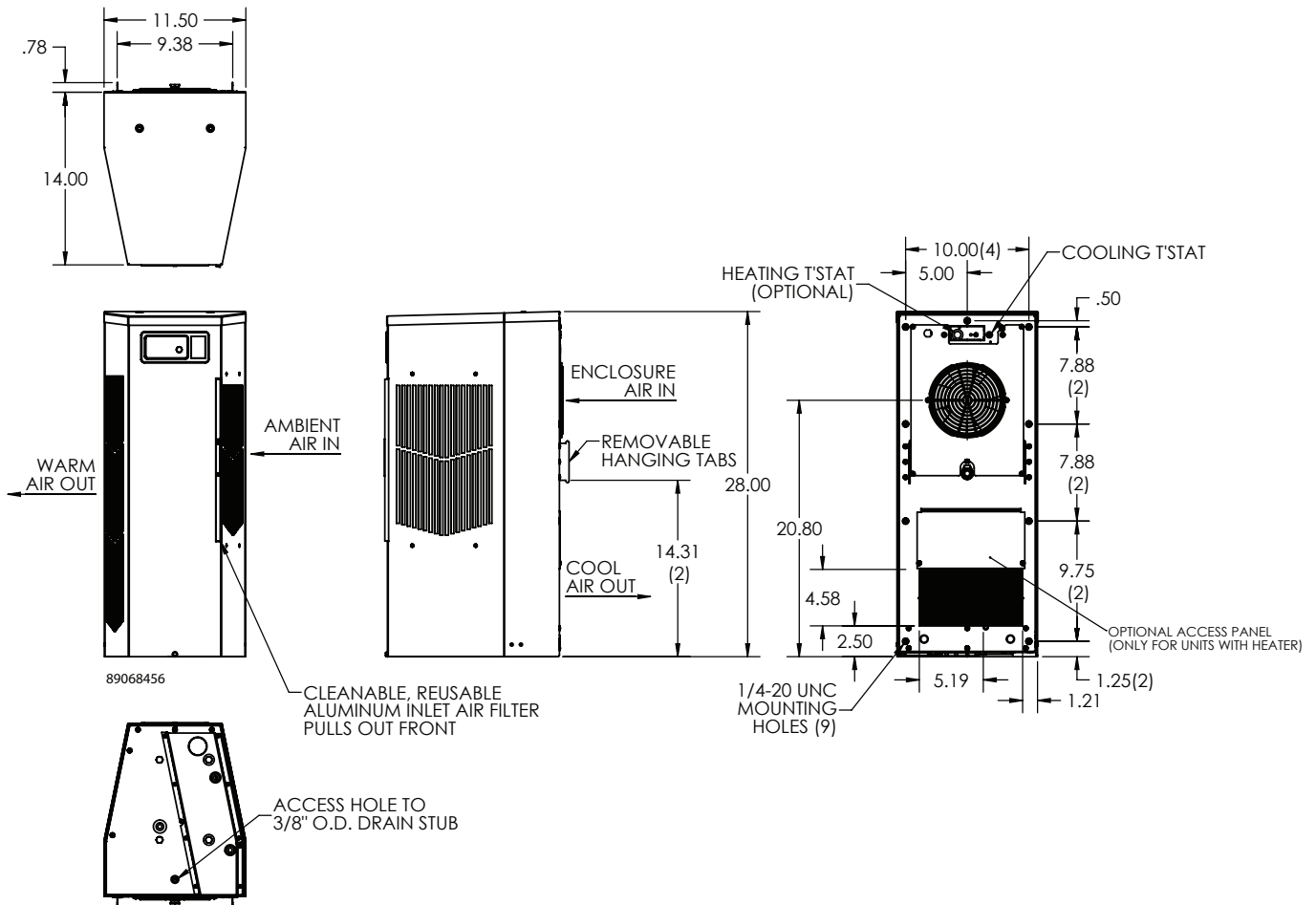

# INSTALLATION INSTRUCTIONS

1. Inspect the air conditioner and verify correct functionality before mounting the air conditioner. See HANDLING AND TESTING THE AIR CONDITIONER on page 3.
2. Using the mounting gasket kit provided with the unit, install gaskets to the air conditioner, see Figure 1.
3. Mount air conditioner on enclosure taking care not to damage the mounting gasket. The mounting gasket is the seal between the air conditioner and the enclosure. Avoid dragging the air conditioner on the enclosure with the mounting gasket attached as this could cause rips or tears in the gasket and risk losing the water tight seal.
4. Allow unit to remain upright for a minimum of five (5) minutes before starting. CAUTION! Air conditioner must be in upright position during operation.
5. Refer to the nameplate for electrical requirements. Wire the unit to a properly grounded power supply. Electrical circuit should be fused with slow blow or HACR circuit breaker.
6. Some air conditioners require a remote mounted thermostat. Wire the thermostat outputs to the appropriate terminals on the 24 VAC terminal strip by noting the locations on the correct wiring diagram.
7. Set thermostat for required cabinet temperature. Refer to Sequence of Operation on page 4 for thermostat adjustment and operation.

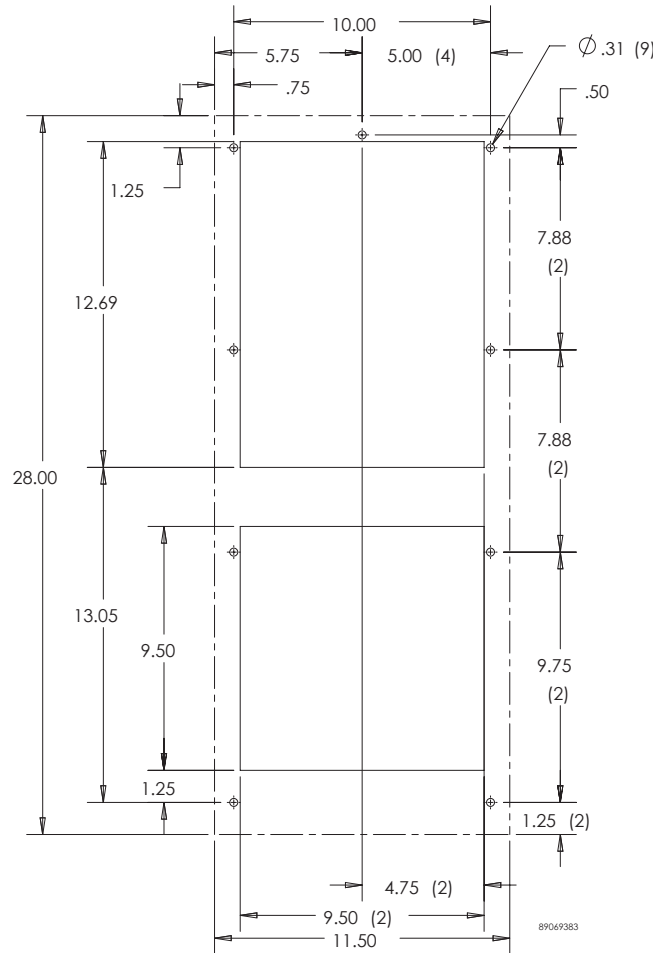

Surface Mount

Figure 1  
Cut-out Drawing

# REMOTE ACCESS CONTROL (OPTIONAL)

## INTRODUCTION

The Remote Access Control is a parametric controller for the complete management of air conditioners. All settings are pre-programmed at the factory. Cooling/heating set-points, cooling/heating differential and high /low temperature alarm set-points can be adjusted by the user. Alarms are outputted through a relay contact and also can be accessed through an Ethernet connection utilizing SNMP. A USB connection is also provided and can be used to interface with the controller utilizing ModBus.

## ENERGIZING THE CONTROLLER

The controller is wired and programmed at the factory to be energized when power is supplied to the air conditioner.

## CONTROL STATUS INDICATION

The display has numerous symbols that indicate if the controller is heating, cooling, alarming, if the compressor is enabled, and if the ambient fan is enabled. The 3 alpha-numeric characters further describe alarms and show the cabinet temperature by default.

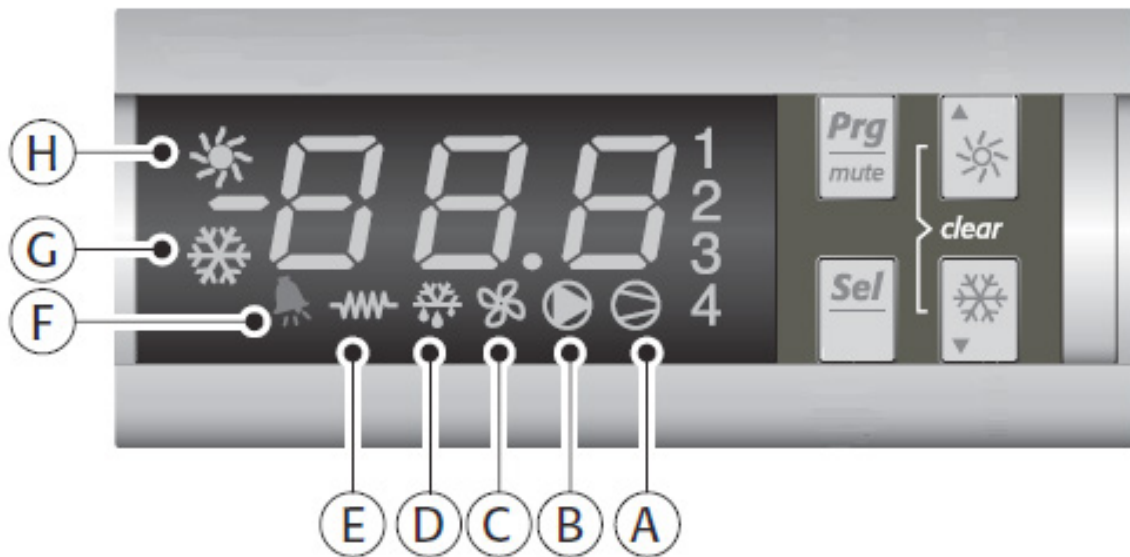

SYMBOL	COLOR	ICON ON	ICON FLASHING
1	AMBER	Compressor On	Start-up Request
2,3,4	AMBER	Not Used	Not Used
A	AMBER	Compressor On	Not Used
B	AMBER	Evaporator Fan On	Start-up Request
C	AMBER	Not Used	Not Used
D	AMBER	Not Used	Not Used
E	AMBER	Heater Active	Not Used
F	RED	Alarm Active	Not Used
G	AMBER	Controller Active	Not Used
H	AMBER	Not Used	Not Used

## DISPLAYING AND CHANGING PROGRAM VARIABLES

**Access:** To view and/or change parameters, press and hold the Prg and Sel buttons for greater than 5 seconds. Press the up or down arrow buttons until "22" is displayed, then press Sel button. When "S-P" is displayed, press Sel.

**Navigation:** Press up or down arrows to display sub-menus then press Sel to select the desired sub-menu. In the sub-menu, use up or down arrows to display parameters for viewing or changing and press Sel. Use Prg button to back out of menu levels as desired.

**Adjust:** Use the up or down arrows to change the parameter value then push Sel to save that setting. If Sel is not pressed, the change to the value will not be saved. Navigate to and change other parameters as desired. When finished, push Prg to back out of the sub-menus to the main menu.

**NOTE: The display will revert to normal temperature display mode if no buttons are pressed for 60 seconds.**

### OPERATING PARAMETERS

Parameter	Default Value	Range	Description
r01	80 F	72 F to 120 F	Cooling set-point
r02	7 F	-	Cooling differential
A04	50 F*	32 F to 60 F	Heating set-point*
A05	7 F*	-	Heating differential*

Cooling turns on at r01 + r02, and off at r01

Heating turns on at A04, and off at A04 + A05

\*Functional only on units with heater option

### ALARM PARAMETERS

Parameter	Default Value	Description
P16	125 F	High Temperature Alarm
P19	40 F	Low Temperature Alarm

## DISPLAYING TEMPERATURE SENSOR #2

Sensor number 2, the air outlet or condenser coil sensor, can be viewed at any time by pressing the up or down arrow button on the front panel of the controller display. The display will revert to displaying temperature sensor number 1 (the AC inlet temperature) after 60 seconds. Both sensors can also be read through the Ethernet and USB connections.

## COMPRESSOR RESTART TIME DELAY

A factory set 6 minute (360 second) restart delay exists to reduce residual back pressure before allowing the compressor to restart. The compressor will stay off for the entire restart duration after the compressor is disabled. A flashing "1" on the controller display will indicate the unit is in a compressor restart delay while calling for cooling.

## ALARM OUTPUT CONTACT

The Remote Access Control has a normally open dry contact alarm output with a resistive load rating of 250 VAC at 3 amps. Two yellow 18 AWG wires located at the back of the air conditioner provide a connection to this output.

## ALARM INPUT CONNECTION

The Remote Access Control can accept a dry contact/switch input via the two 18 AWG white wires located at the back of the air conditioner. This input is associated with the controller display alarm mnemonic TP (door open and/or smoke detected). [To use this feature, remove the splice connector connecting the two white wires and connect customer supplied enclosure door switch in its place.]

## ALARM CONDITION DISPLAY

There are seven possible non-latching alarm conditions detectable by the controller and are indicated on the controller display. All alarms can also be accessed through the Ethernet and USB connections.

Alarm Mnemonic	Description	Cause	Result	Alarm Relay
TP	General Alarm	Door open and/or smoke detected	Unit turns off for duration of alarm	Relay Contacts Close
LA	High Pressure Warning	MALF high pressure switch opens	No effect on function	N/A
E1	Air Inlet Temperature Sensor Alarm	Sensor Failure	Unit turns off for duration of alarm	Relay Contacts Close
E2	Air Outlet Temperature Sensor Alarm	Sensor Failure	Unit turns off for duration of alarm	Relay Contacts Close
Ht	High Temperature Alarm Default = 125 F	Cabinet over temperature Alarm clears at default setting -2 F	No effect on function	Relay Contacts Close
Lt	Low Temperature Alarm Default = 40 F	Cabinet under temperature Alarm clears at default setting +27 F	No effect on function	Relay Contacts Close
A1	Frost Alarm	Evaporator coil frozen Alarm clears at 59 F	Compressor and Evaporator fan off for duration of alarm	Relay Contacts Close

## AIR CONDITIONER UNIT COMMUNICATION FEATURES

Air conditioner units equipped with communication capabilities provide both SNMP protocol through Ethernet and ModBus protocol via USB. Pentair has a PC Interface Tool available for download that can utilize either mode to communicate with the air conditioner unit.

### USB COMMUNICATION

This communication mode allows direct connection of a PC to the air conditioner unit. The protocol supported is ModBus. Use the PC Interface Tool to communicate with the air conditioner unit. A MINI-b USB connection is provided.

### ETHERNET COMMUNICATION

This communication mode allows remote connection to the air conditioner unit protocol supported by SNMP. Customers can use their own software with the provided MIB file, or use the PC Interface Tool to communicate with the air conditioner unit. An RJ45 connection is provided.

**Note: ACU has a default IP Address of 192.168.1.2**

Both Ethernet and USB communication modes allow the ability to:

- Read ACU inlet and outlet air temperatures
- Read and change Cooling Set-point and Cooling Differential
- Read and change Heating Set-point, Heating Differential
- Read and change High and Low Temperature Alarm Settings
- Read and change Gateway IP Address, Device IP Address, Subnet Mask, Trap IP Address and Community
- Read and change Unit Identification
- Read and change the state of IP addressing (static or dynamic)
- Read current Alarm Status

## SOFTWARE AND MIB FILE DOWNLOADS

The PC Interface Tool and the SNMP MIB file can be downloaded from [www.hoffmanonline.com](http://www.hoffmanonline.com).

## USING THE PC INTERFACE TOOL

The PC Interface Tool gives the user the ability to communicate with the air conditioner unit to read/write parameters using either Ethernet or USB connections.

## USB COMMUNICATION MODE

**NOTE: Before connecting unit to the PC, make note of the comm ports present. After the unit is connected to the PC, a new comm port will be added to the list. Use this new comm port.**

- From **Tools** menu select **Use Ethernet**
- When **Use Ethernet** is unchecked, then **Comm Port** menu is enabled, **Device IP** and **Community** boxes are not shown, and USB communication can be used
- To set the comm port, choose **Comm Port** from the **Tools** menu and then select the comm port from the combo box

## VIEWING AIR CONDITIONER UNIT VALUES

To view Air Conditioner Unit values

- Select the **ACU Values** tab
- Select the **Enable Comm** button (the PC Interface will now be communicating with unit)
- To stop communication select the **Disable Comm** button

## CHANGING AIR CONDITIONER UNIT VALUES

To change **ACU Values**

- Select the **Settings** tab
- Select the value to change
- Make the change to the value
- Select the **Change Setting** button
- Change can be verified in **ACU Values** tab

## VIEWING AND CHANGING ETHERNET INFORMATION

To view and change Ethernet Information

- Select **Ethernet Info** tab

To view Ethernet Information

- Click **Read Ethernet Info** button

To change to dynamically assigning IP Address Mode

- Check **Use DHCP Server** checkbox
- Enter Trap IP Address and Community
- Click **Load Ethernet Info** button

To change to statically assigning IP Address Mode

- Uncheck **Use DHCP Server** checkbox
- Enter Device IP Address, Subnet Mask, Gateway IP Address, Trap IP Address and Community
- Click **Load Ethernet Info** button

## ETHERNET COMMUNICATION MODE

- From **Tools** menu select **Use Ethernet**
- When **Use Ethernet** is checked, **Comm Port** selection is disabled, **Device IP** and **Community** boxes are shown and Ethernet communication can be used.
- Enter unit's IP Address and Community string in **Device IP** and **Community** boxes at the bottom of the PC Interface Tool.

**Each unit has two community strings. One is a Read/Write community string (defaulted to 'private') that can be changed by the customer (must be 4 to 8 characters long). The other is a Read-Only community string ('public') and cannot be changed.**

### VIEWING AIR CONDITIONER UNIT VALUES

To view Air Conditioner Unit values

- Select the **ACU Values** tab
- Select the **Enable Comm** button (the PC Interface will now be communicating with unit)
- To stop communication select the **Disable Comm** button

### CHANGING AIR CONDITIONER UNIT VALUES

To change **ACU Values**

- Select the **Settings** tab
- Select the value to change
- Make the change to the value
- Select the **Change Setting** button
- Change can be verified in **ACU Values** tab

### VIEWING AND CHANGING ETHERNET INFORMATION

To view and change Ethernet Information

- Select **Ethernet Info** tab

To view Ethernet Information

- Click **Read Ethernet Info** button

To change to dynamically assigning IP Address Mode

- Check **Use DHCP Server** checkbox
- Enter Trap IP Address and Community
- Click **Load Ethernet Info** button

To change to statically assigning IP Address Mode

- Uncheck **Use DHCP Server** checkbox
- Enter Device IP Address, Subnet Mask, Gateway IP Address, Trap IP Address and Community
- Click **Load Ethernet Info** button

### ALARM LOG ACCESSIBLE WITH SNMP

- Using custom software with provided MIB file gives the ability to view a log of the last 25 alarms



### REMOTE ACCESS CONTROL PIN-OUT

	FUNCTION	NAME	PIN #	WIRE #
U1 OUTPUTS	COOL	No1	1	ORG78
		C1/2	2	BLK
	HEAT	No2	7	BRN76
		C1/2	3	BLK
	ENCL MI	No3	8	BLK77
		C3/4	4	BLK
	NA	No4 (na)	9	BLK
		C3/4	10	BLK
	ALARM RELAY OUTPUT	No5	12	YEL39
		C5	6	YEL38
	NA	x	5	NA
	NA	x	11	NA
U2 INPUTS	ALARM INPUT CONNECTION	ID1	8	WHT63
	MALFUNCTION NC SWITCH	ID2	1	BLU88
	NA	ID3 (na)	9	BLU
	NA	ID4 (na)	2	BLU
	NA	ID5 (na)	10	BLU
	DIGITAL INPUT GROUND	ID GND	3	BLU
	NA	Y (na)	4	NA
	NA	GND (na)	5	NA
	T1, EVAP IN THERMISTOR	B1	13	RED
	T2, EVAP OUT THERMISTOR	B2	12	RED
	T1, T2 GND	GND	6	WHT
	NA	B3	11	NA
	CONTROLLER POWER	G	7	BLK40
	CONTROLLER POWER	G0	14	WHT41
	U3 DATA	POWER		1
GROUND			2	BLACK
DIRECTION			3	GREEN
DATA			4	WHITE

# SCHEMATICS AND WIRING DIAGRAMS FOR REMOTE ACCESS CONTROL

## GENERIC 1-PHASE SCHEMATIC EXCEPT 230V 50HZ (ACTUAL UNIT OPTIONS MAY VARY)

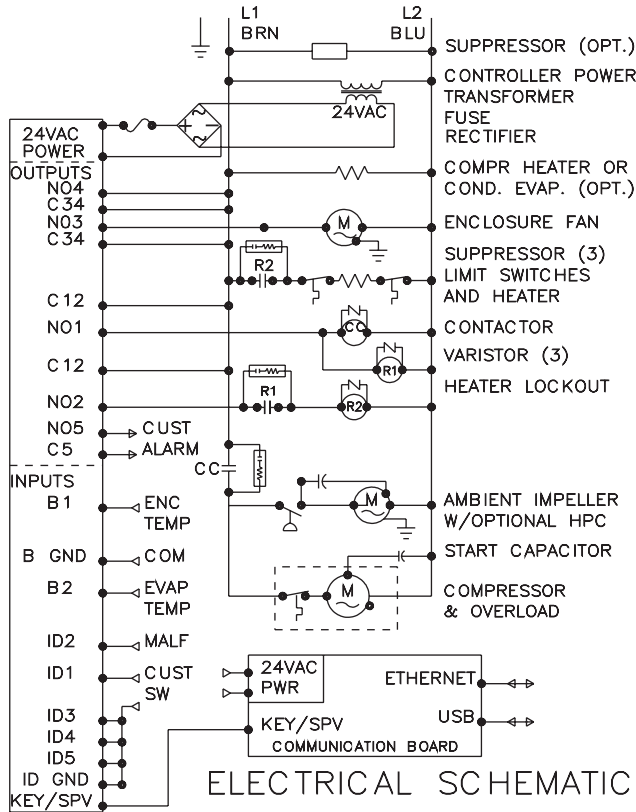

## GENERIC 230V 50HZ 1-PHASE SCHEMATIC (ACTUAL UNIT OPTIONS MAY VARY)

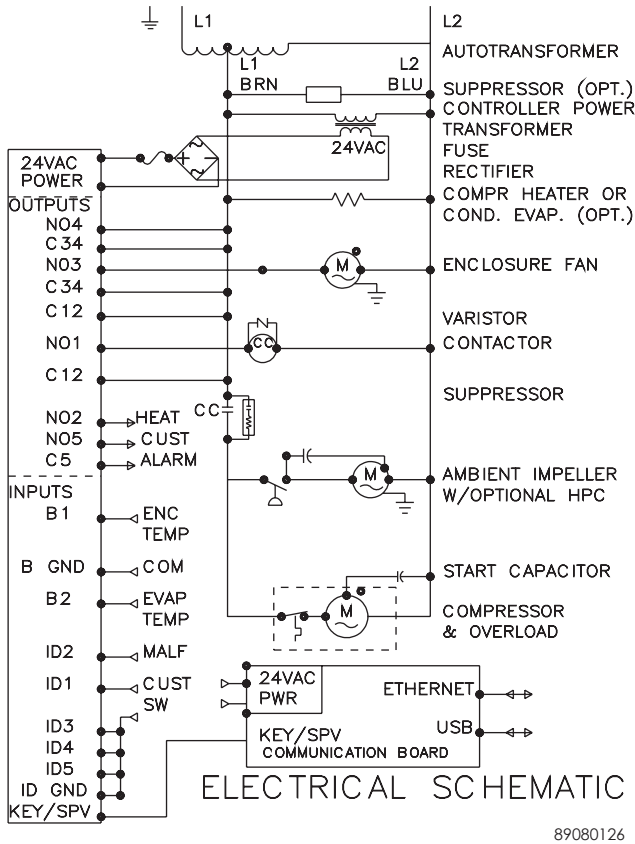

# GENERIC 1-PHASE WIRE DIAGRAM FOR REMOTE ACCESS CONTROL (ACTUAL UNIT OPTIONS MAY VARY)

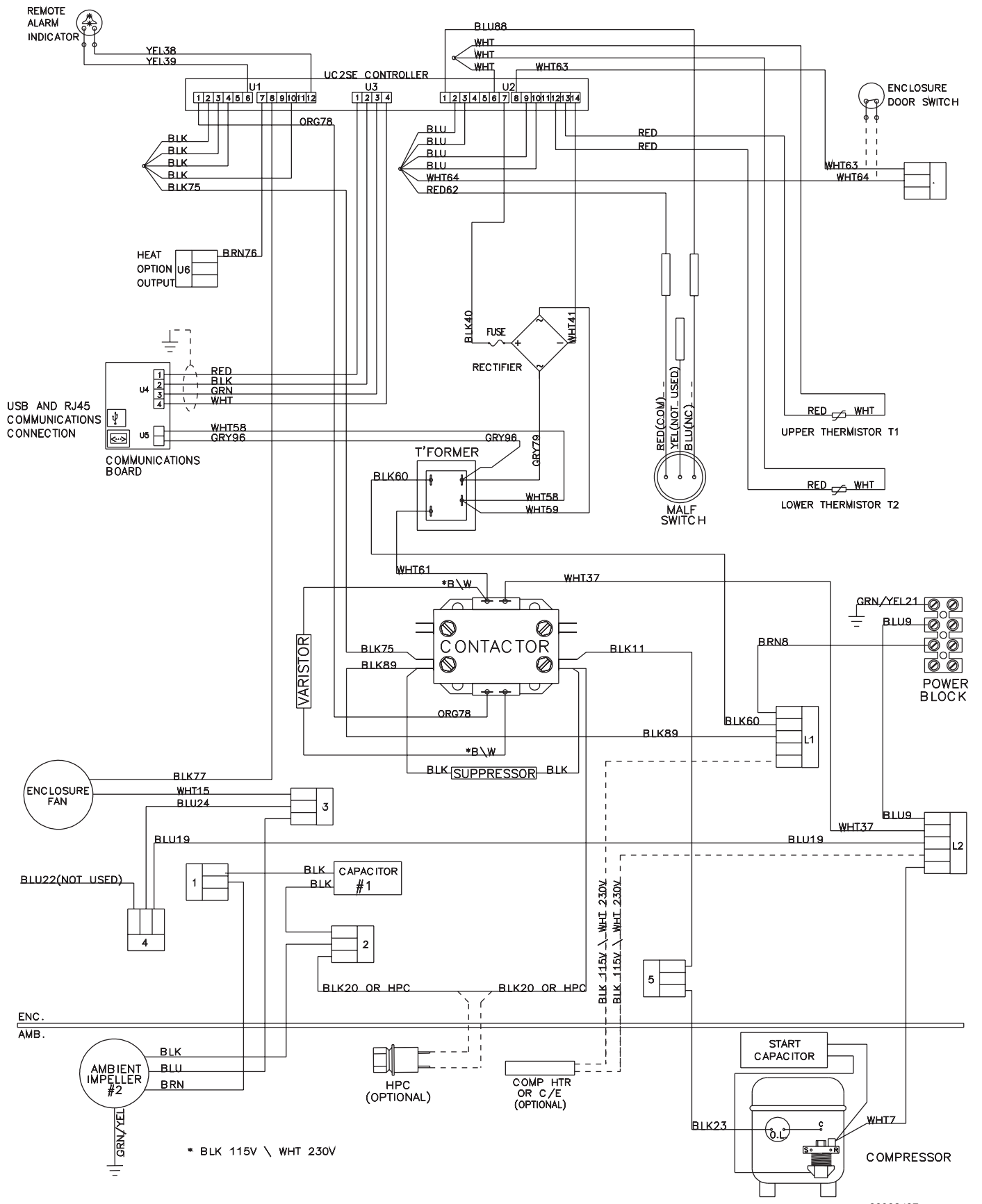

89082437

# 230V 50HZ 1-PHASE WIRE DIAGRAM FOR REMOTE ACCESS CONTROL (ACTUAL UNIT OPTIONS MAY VARY)

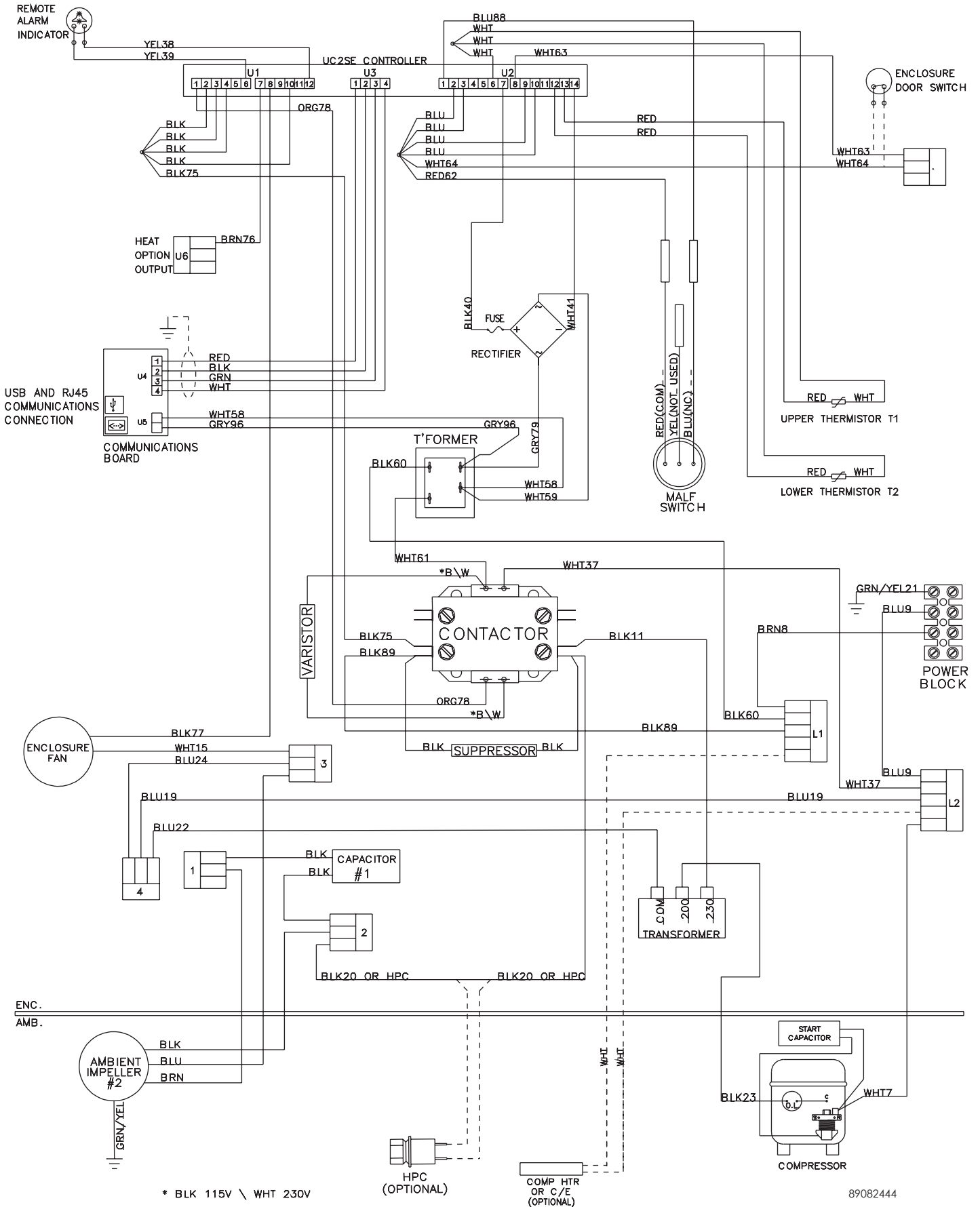

# DIMENSIONAL DRAWING WITH REMOTE ACCESS CONTROL

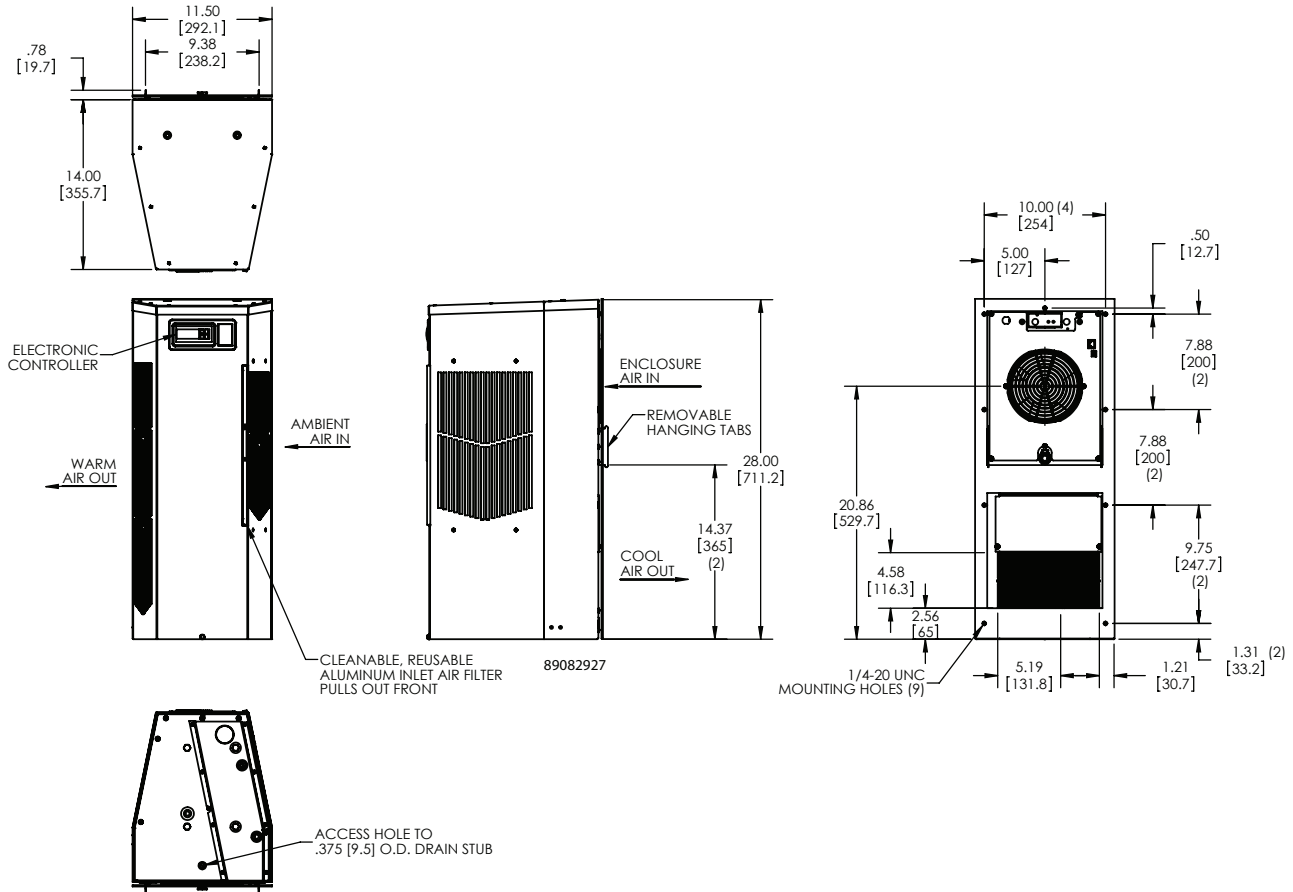

# INSTALLATION INSTRUCTIONS WITH REMOTE ACCESS CONTROL

1. Inspect the air conditioner and verify correct functionality before mounting the air conditioner. See HANDLING AND TESTING THE AIR CONDITIONER on page 3.
2. Using the mounting gasket kit provided with the unit, install gaskets to the air conditioner, see Figure 2.
3. Mount air conditioner on enclosure taking care not to damage the mounting gasket. The mounting gasket is the seal between the air conditioner and the enclosure. Avoid dragging the air conditioner on the enclosure with the mounting gasket attached as this could cause rips or tears in the gasket and risk losing the water tight seal.
4. Allow unit to remain upright for a minimum of five (5) minutes before starting. CAUTION! Air conditioner must be in upright position during operation.
5. Refer to the nameplate for electrical requirements. Wire the unit to a properly grounded power supply. Electrical circuit should be fused with slow blow or HACR circuit breaker.
6. Set controller setpoints for required cabinet temperature. Refer to DISPLAYING AND CHANGING PROGRAM VARIABLES on page 13 for setpoint adjustment and operation.

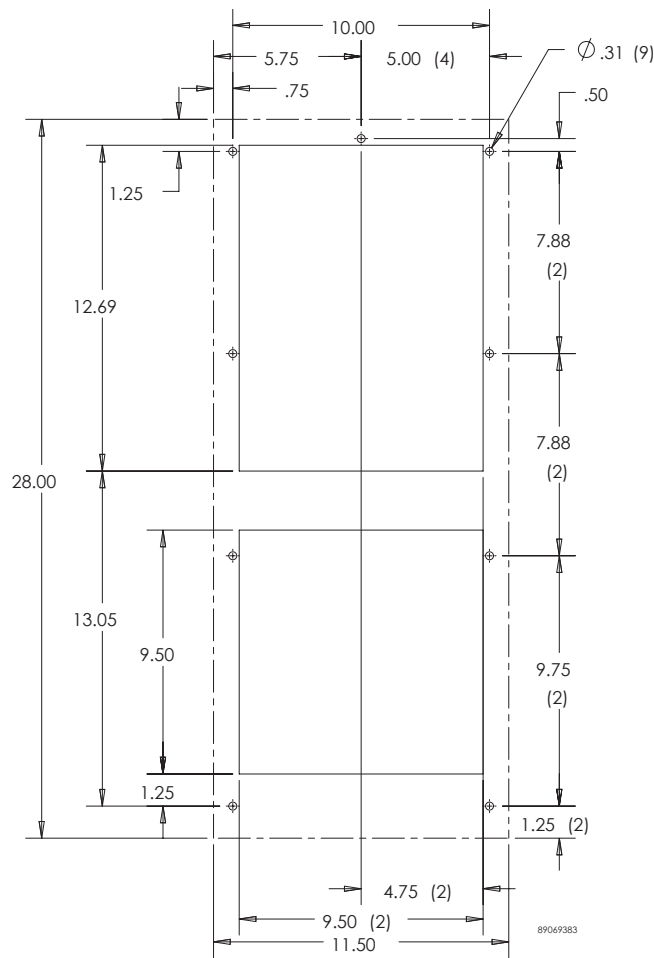

Surface Mount

Figure 2  
Cut-out Drawing

## **MAINTENANCE**

### **COMPRESSOR**

The compressor requires no maintenance. It is hermetically sealed, properly lubricated at the factory and should provide years of satisfactory operating service.

Under no circumstances should the access fitting covers be loosened, removed or tampered with.

Breaking of seals on compressor access fittings during warranty period will void warranty on hermetic system.

Recharging ports are provided for the ease and convenience of reputable refrigeration repair service personnel for recharging the air conditioner.

### **INLET AIR FILTER**

This air conditioner was designed with a dust resistant condenser coil. This allows it to be run filterless in most applications. The air conditioner is shipped with a filter in place for your convenience. For filterless operation, simply remove the filter. Should you decide the filter is necessary in your application, regular maintenance to clean this filter will assure normal operation of the air conditioner. The easily removable inlet air filter is located behind the front cover. If necessary filter maintenance is delayed or ignored, the maximum ambient temperatures under which the unit is designed to operate will be decreased.

If the compressor's operating temperature increases above designed conditions due to a dirty or clogged filter (or plugged condenser coil), the air conditioner's compressor will stop operating due to actuation of the thermal overload cut-out switch located on the compressor housing. As soon as the compressor temperature has dropped to within the switch's cut-in setting, the compressor will restart automatically. However the above condition will continue to take place until the filter or coil has been cleaned. It is recommended that power to the air conditioner be interrupted intentionally when abnormally high compressor operating temperature causes automatic shut-down of the unit. The above described shut-down is symptomatic of a clogged or dirty filter, thus causing a reduction in cooling air flow across the surface of the compressor and condenser coil.

### **HOW TO REMOVE, CLEAN OR INSTALL A NEW INLET AIR FILTER**

RP aluminum washable air filters are designed to provide excellent filtering efficiency with a high dust holding capacity and a minimum amount of resistance to air flow. Because they are constructed entirely of aluminum they are lightweight and easy to service. To achieve maximum performance from your air handling equipment, air filters should be cleaned on a regular basis.

The inlet air filter is located behind the front access cover. To access the filter, loosen the access-cover screw. Swing top edge of access cover forward. Slide air filter up and out of retaining tabs. The filter may now be cleaned or new filter installed.

Cleaning Instructions:

1. Flush the filter with warm water from the exhaust side to the intake side. **DO NOT USE CAUSTICS.**
2. After flushing, allow filter to drain. Placing it with a corner down will assure complete drainage.

## CONDENSER AND EVAPORATOR AIR MOVERS

Impeller motors require no maintenance. All bearings, shafts, etc. are lubricated during manufacturing for the life of the motor.

If one of the condenser impeller motors (ambient impellers) should fail, it is not necessary to remove the air conditioner from the cabinet or enclosure to replace the blower. The condenser blower is mounted on its own bulkhead and is easily accessible by removing the front cover.

 <b>CAUTION</b>
Operation of the air conditioner in areas containing airborne caustics or chemicals can rapidly deteriorate filters, condenser coils, blowers and motors, etc. Contact Pentair Equipment Protection for special recommendations.

## REFRIGERANT LOSS

Each air conditioner is thoroughly tested prior to leaving the factory to insure against refrigeration leaks. Shipping damage or microscopic leaks not found with sensitive electronic refrigerant leak detection equipment during manufacture may require repair or recharging of the system. This work should only be performed by qualified professionals, generally available through a local, reputable air conditioning repair or service company.

Should the refrigerant charge be lost, access ports on the suction and discharge sides of the compressor are provided for recharging and/or checking suction and discharge pressures.

Refer to the data on the nameplate which specifies the type of refrigerant and the charge size in ounces.

Before recharging, make sure there are no leaks and that the system has been properly evacuated into a deep vacuum.

### REFRIGERANT PROPERTIES CHART (R134A)

°F	°C	Pressure		°F	°C	Pressure
-40	-40	-14.7		60	15.6	58
-35	-37.2	-12.3		65	18.3	64
-30	-34.4	-9.7		70	21.1	71.5
-25	-31.7	-6.8		75	23.9	78
-20	-28.9	-4		80	26.7	86.7
-15	-26.1	0		85	29.4	95
-10	-23.3	2		90	32.2	105
-5	-20.6	4		95	35	113.3
0	-17.8	7.5		100	37.8	125
5	-15	9		105	40.6	135
10	-12.2	12		110	43.3	146.7
15	-9.4	15		115	46.1	157.5
20	-6.7	18.5		120	48.9	170
25	-3.9	22		125	51.7	185
30	-1.1	26				
35	1.7	30				
40	4.4	35				
45	7.2	40				
50	10	45.5				
55	12.8	51.5				



## UNIT CHARACTERISTICS

	Model			
	N280416GXXX	N280426GXXX	N280425GXXX	N280446GXXX
<b>Dimensional Data</b>				
Height	28" / 711.2 mm			
Width	11.5" / 292.1 mm			
Depth	14" / 355.6 mm			
Unit Weight	84 lbs / 38 kg	84 lbs / 38 kg	92 lbs / 42 kg	98 lbs / 44 kg
Unit Protection Rating	Type 12/4/4X/3R			
<b>Cooling Data</b>				
Refrigerant	R134a			
Refrigerant Charge	11 oz.			
Cooling Capacity at 95 F Enclosure 95 F Ambient (BTU/Hr.)	3589/3974	3690	3298	3690
Cooling Capacity at Max Conditions (BTU/Hr.)	3805/4162	4394	3818	4394
Maximum Ambient Temp	125 F / 52 C			
Minimum Ambient Temp	-40 F / -40 C			
Enclosure Airflow	143 CFM			
External Airflow	288 CFM			
Condensate Management	Hose discharge / Optional powered C/E			
<b>Heating Data</b>				
Capacity	1300 W			N/A
<b>Electrical Data</b>				
Rated Voltage (50/60 Hz)	115 V	230 V	230 V	460 V
Rated Frequency	50 / 60 Hz	60 Hz	50 Hz	60 Hz
Voltage Range	+/- 10% of rated			
Cooling Amps at Max Conditions	11.6/11.2	6.5	5.8	3.3
Heating Amps	12.2	6.2	6.2	N/A
Compressor RLA / LRA	8.1/40.0	24.5	5.3	24.5
Evaporator Fan RLA	.38/.36	.19	.18	.19
Condenser Fan RLA	.78/.93	.53	.39	.53

## FUNCTIONAL DATA

Unit	Evaporator Air In(°F)	Amps(A)	Condenser Delta(°F)	Evaporator Delta(°F)
N280416GXXX	65-80	7.3-8.9	15-23	22-31
	80-100	7.9-9.9	17-26	25-31
N280426GXXX	65-80	4.7-5.8	14-23	21-32
	80-100	4.8-6.3	17-28	26-38
N280425GXXX	65-80	3.2/4.5	14-22	19-29
	80-100	3.5/5.2	16-26	23-35
N280446GXXX	65-80	2.4-2.9	14-23	21-32
	80-100	2.4-3.2	17-28	26-38

# SERVICE DATA

## COMPONENTS LIST

Part Description	Part Number			
	115 V	230 V 60 Hz	230 V 50 Hz	460 V 60 Hz
Capacitor, Compressor, Start	89074579	89074578	89074578	89074578
Capacitor, Condenser Impeller	52-6032-13	52-6032-14	52-6032-14	52-6032-14
Coil, Condenser	89068416	89068416	89068416	89068416
Coil, Evaporator	89068414	89068414	89068414	89068414
Compressor	89069347	89069349	89069349	89069349
Filter, Air, Reusable	89068420	89068420	89068420	89068420
Filter/Dryer	52-6028-00	52-6028-00	52-6028-00	52-6028-00
Head Pressure Control Switch (option)	52-6104-26	52-6104-26	52-6104-26	52-6104-26
Impeller, Condenser	10-1091-123	10-1091-124	10-1091-124	10-1091-124
Fan, Evaporator	10-1012-01	10-1012-02	10-1012-02	10-1012-02
Relay, Compressor Start	89074581	89074580	89074580	89074580
Capillary Tube	99-0540-50	99-0640-55	99-0640-55	99-0640-55
Thermostat, SPDT, 55-100F	10-1061-16	10-1061-16	10-1061-16	10-1061-16
Transformer, Compressor Input Power	N/A	N/A	10-1006-134	N/A
Transformer, Input Power	N/A	N/A	N/A	10-1006-111
Controller, Basic	89075653			
Thermistor	89075654			
Bridge Rectifier	89087424			
Controller Wires with pins (24)	89083091			
Communication Board	89082033			
Communication Cable	89080313			
315 mA Fuse	89085115			

**NOTES**

## N28-0416-GXXX PRESSURE TABLES

N280416GXXX 50hz		L=SUCTION (± 5PSIG); H=HEAD (-10/+20PSIG)															
Ambient Temperature (°F)	ENCLOSURE TEMPERATURE (°F)																
	°F	70		80		90		95		100		113		120		125	
		L	H	L	H	L	H	L	H	L	H	L	H	L	H	L	H
70	25	120	27	124	29	127	30	129	31	131	34	136	35	138	36	140	
80	27	146	30	150	32	154	33	156	34	158	37	163	38	166	39	168	
90	30	172	32	176	34	181	36	183	37	185	40	191	41	194	43	197	
95	31	185	33	189	36	194	38	192	38	199	41	205	43	209	44	211	
100	32	197	35	202	37	208	38	210	40	213	43	219	45	223	46	225	
113	35	231	38	237	41	242	42	245	43	248	47	255	49	259	50	262	
120	37	249	40	255	42	261	44	264	45	267	49	275	51	279	52	282	
125	38	262	41	268	44	274	45	277	47	281	51	289	53	293	54	296	

N280416GXXX 60hz		L=SUCTION (± 5PSIG); H=HEAD (-10/+20PSIG)															
Ambient Temperature (°F)	ENCLOSURE TEMPERATURE (°F)																
	°F	70		80		90		95		100		113		120		125	
		L	H	L	H	L	H	L	H	L	H	L	H	L	H	L	H
70	21	123	22	125	24	128	24	129	25	130	26	133	27	135	28	136	
80	24	148	25	152	27	155	27	156	28	158	30	162	31	164	32	166	
90	26	174	28	178	30	182	31	184	31	186	34	191	35	194	36	196	
95	27	187	29	191	31	195	33	192	33	200	36	206	37	209	38	211	
100	29	199	31	204	33	209	34	211	35	214	38	220	39	224	40	226	
113	32	232	34	238	37	244	38	247	39	250	42	258	44	262	45	265	
120	34	250	36	257	39	263	40	267	42	270	45	278	47	283	48	286	
125	35	263	38	270	40	277	42	280	43	284	47	293	49	298	50	301	

## N28-0426-GXXX PRESSURE TABLES

N280426GXXX 50hz		L=SUCTION (± 5PSIG); H=HEAD (-10/+20PSIG)															
Ambient Temperature (°F)		ENCLOSURE TEMPERATURE (°F)															
		70		80		90		95		100		113		120		125	
		L	H	L	H	L	H	L	H	L	H	L	H	L	H	L	H
70	28	118	31	123	35	129	36	132	38	134	42	143	44	145	46	148	
80	31	144	35	150	38	156	40	160	42	163	46	172	48	175	50	178	
90	34	170	38	177	42	184	43	187	45	191	50	202	53	205	54	209	
95	36	183	39	190	43	198	44	191	47	205	52	216	55	220	56	224	
100	37	195	41	203	45	211	47	215	49	219	54	231	57	235	59	239	
113	41	229	45	238	50	247	52	252	54	256	59	270	62	274	64	279	
120	43	247	48	257	52	266	54	271	56	276	62	290	65	295	67	300	
125	45	260	49	270	54	280	56	285	58	290	64	305	67	310	69	315	

N280426GXXX 60hz		L=SUCTION (± 5PSIG); H=HEAD (-10/+20PSIG)															
Ambient Temperature (°F)		ENCLOSURE TEMPERATURE (°F)															
		70		80		90		95		100		113		120		125	
		L	H	L	H	L	H	L	H	L	H	L	H	L	H	L	H
70	27	125	30	131	33	136	35	139	36	142	41	149	42	153	44	156	
80	30	151	33	157	36	164	38	167	39	170	44	179	46	183	48	187	
90	32	177	36	184	39	192	41	195	43	199	48	209	50	214	51	217	
95	34	190	37	198	41	206	42	202	44	213	50	223	51	229	53	233	
100	35	203	39	211	42	219	44	224	46	228	51	238	53	244	55	248	
113	39	237	43	246	46	255	48	260	50	265	56	277	58	283	60	288	
120	41	255	45	265	48	275	50	280	52	285	58	298	60	305	62	310	
125	42	268	46	278	50	289	52	294	54	299	60	313	62	320	64	325	

# TROUBLE SHOOTING

## BASIC AIR CONDITIONING TROUBLE SHOOTING CHECK LIST - THERMOSTAT VERSION

1. Check manufacturer's nameplate located on the unit for correct power supply.
2. Turn on power to the unit. The evaporator (Enclosure or "COLD" air) impeller should come on. Is there airflow?

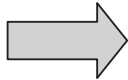
YES, proceed to step 3.
NO, possible problem: <ul style="list-style-type: none"><li>• Open motor winding</li><li>• Stuck impeller motor</li><li>• Obstructed wheel</li></ul>

<b>Repair or Replace defective part</b>

3. Check thermostat setting and adjust thermostat to the lowest setting. This should turn the condenser impellers and the compressor on. Did condenser impellers and compressor come on when the thermostat was turned on?

YES, proceed to step 4.
NO, possible problem: <ul style="list-style-type: none"><li>• Tripped customer door switch</li><li>• Defective thermostat</li></ul>

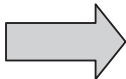
<b>Replace part</b>

4. Are all impellers and the compressor running? If not the unit will not cool properly.
5. Check condenser (Ambient or "HOT" air) impellers for airflow. Is there airflow?

YES, proceed to step 6.
NO, possible problem: <ul style="list-style-type: none"><li>• Defective thermostat</li><li>• Open motor winding</li><li>• Stuck impeller motor</li><li>• Obstructed wheel</li></ul>

<b>Repair or Replace defective part</b>

6. Carefully check the compressor for operation - motor should cause slight vibration, and the outer case of the compressor should be warm. Is the compressor showing signs of this?

YES, wait 5 minutes, then proceed to step 7.
NO, possible problem: <ul style="list-style-type: none"><li>• Defective thermostat</li><li>• Defective overload</li><li>• Defective relay</li></ul>

<b>Repair or Replace defective part</b>

7. Make sure the coils are clean. Then check evaporator "air in" and "air out" temperatures. If the temperatures are the same:

<ul style="list-style-type: none"><li>• Possible loss of refrigerant</li><li>• Possible bad valves in the compressor</li></ul>

<b>Repair or Replace defective part</b>

8. To check for a bad thermostat, turn power to the unit off. Remove the upper access panel and place both thermostat wires onto one terminal (replace upper access panel for safety). This will activate the switch in the thermostat. Turn the power on and if all impellers and the compressor come on, the thermostat needs to be replaced.

## SYMPTOMS AND POSSIBLE CAUSES - THERMOSTAT VERSION

SYMPTOM	POSSIBLE CAUSE
Unit won't cool	Clogged fins on coil(s)
	Dirty filter
	Impellers not running
	Compressor not running
	Compressor runs, but has bad valves
	Loss of refrigerant
Compressor tries to start but won't run	Low line voltage at start. Should be +/- 10% rated voltage.
	Compressor motor stuck
	Bad contactor
	Bad overload switch
	Bad run/start capacitor
Unit blows breakers	Undersized breaker/fuse or not time delayed
	Short in system
Getting water in enclosure	Drain plugged
	Drain tube kinked
	Enclosure not sealed (allowing humidity in)
	Mounting gasket damaged

**For additional technical support, contact Pentair Equipment Protection at 800-896-2665.**

# BASIC AIR CONDITIONING TROUBLE SHOOTING CHECK LIST - REMOTE ACCESS CONTROL VERSION

1. Check manufacturer's nameplate located on the unit for correct power supply.
2. Turn on power to the unit. The controller will display a start up sequence then revert to the normal temperature display mode. Is the correct enclosure temperature displayed?

**Note: The temperature may be alternating with an alarm code.**

YES, proceed to step 3.		
NO, possible problem:		
<ul style="list-style-type: none"> <li>• Open controller fuse</li> <li>• Controller in alarm condition. See ALARM CONDITION DISPLAY on page 14.</li> <li>• Defective controller</li> <li>• Defective thermistor - check by blowing warm air across the thermistor. If display temperature rises, thermistor is operable.</li> </ul>		<b>Replace part</b>

3. The cooling status indication (symbol G) should be on. Is the symbol on? If not, press and hold the lower right "snowflake" button for greater than five seconds. Is the cooling mode symbol now on?

YES, proceed to step 4.		
NO, possible problem:		
<ul style="list-style-type: none"> <li>• Defective controller</li> </ul>		<b>Replace part</b>

4. The evaporator (Enclosure or "COLD" air) fan/impeller should turn on. Is there airflow?

YES, proceed to step 5.		
NO, possible problem:		
<ul style="list-style-type: none"> <li>• Controller in alarm condition. See ALARM CONDITION DISPLAY on page 14.</li> <li>• Open motor winding</li> <li>• Stuck fan/impeller</li> <li>• Obstructed blades/wheel</li> <li>• Defective motor capacitor</li> </ul>		<b>Repair or Replace defective part</b>

5. Start the cooling cycle by changing the cooling setpoint parameter (r01) to the low limit of 72 F (22 C). Symbol 1 should be displayed indicating a call for cooling. If symbol 1 is flashing, the unit is in Restart Time Delay mode. Within 6 minutes, symbol 1 should display without flashing. Is symbol 1 displayed without flashing?

YES, proceed to step 8.		
NO, possible problem:		
<ul style="list-style-type: none"> <li>• Unit still in Recycle Time Delay mode</li> <li>• Enclosure temperature below cooling setpoint temperature</li> </ul>		<b>Wait and/or heat enclosure thermistor T1</b>

6. The compressor and the condenser (Ambient or "HOT" air) impeller(s) should turn on. Is there adequate airflow?



YES, proceed to step 7.
NO, possible problem: <ul style="list-style-type: none"> <li>• Open motor winding(s)</li> <li>• Stuck impeller(s)</li> <li>• Obstructed wheel(s)</li> <li>• Defective motor capacitor(s)</li> </ul>

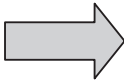

**Repair or Replace defective part**

7. Carefully check the compressor for proper operation - motor should cause slight vibration and the outer case of the compressor should be warm. Is the compressor showing signs of this?

YES, wait 5 minutes, proceed to step 8.
NO, possible problem: <ul style="list-style-type: none"> <li>• Defective start or run capacitor</li> <li>• Defective overload</li> <li>• Defective start relay</li> <li>• Defective contactor</li> <li>• Defective compressor</li> </ul>

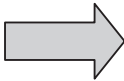

**Repair or Replace defective part**

8. Make sure the coils are clean then check the evaporator “air in” and “air out” temperatures. If the temperatures are the same:

<ul style="list-style-type: none"> <li>• Possible loss of refrigerant</li> <li>• Possible bad valves in compressor</li> </ul>
---

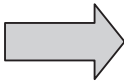

**Repair or Replace defective part**

## SYMPTOMS AND POSSIBLE CAUSES - REMOTE ACCESS CONTROL VERSION

SYMPTOM	POSSIBLE CAUSE
Unit won't cool	Clogged fins on coil(s)
	Dirty filter
	Impellers not running
	Compressor not running
	Compressor runs, but has bad valves
	Loss of refrigerant
Compressor tries to start but won't run	Low line voltage at start. Should be +/-10% rated voltage.
	Compressor motor stuck
	Bad contactor
	Bad overload switch
	Bad run/start capacitor
Unit blows breakers	Undersized breaker/fuse or not time delayed
	Short in system
Getting water in enclosure	Drain plugged
	Drain tube kinked
	Enclosure not sealed (allowing humidity in)
	Mounting gasket damaged

**For additional technical support, contact Pentair Equipment Protection at 800-896-2665.**

## WARRANTY

Pentair Equipment Protection warrants that the Goods manufactured by Pentair Equipment Protection will be free from defects in material and workmanship for a period of one (1) year from the date of shipment by Pentair Equipment Protection, subject to the following conditions and exclusions:

- A. Conditions. All Goods must be installed and operated according to the following specifications:
1. Maximum voltage variation no greater than plus or minus 10% of nameplate nominal rating;
  2. Maximum frequency variation no greater than plus or minus 3 Hz. of nameplate nominal rating;
  3. Must not exceed minimum and maximum stated temperatures on the nameplate;
  4. Must not exceed (BTU/Hr) rating, including any heat sink as indicated on the nameplate;
  5. Refrigerant bearing Goods must not be restarted for a period of one (1) minute after intentional or accidental shut-off;
  6. The filters (if applicable) must be cleaned regularly;
  7. The Goods and any parts thereof must not be modified, unless prior written authorization is received from Pentair Equipment Protection; and
  8. All Goods must be installed and grounded in accordance with all relevant electrical and safety codes, as well as the National Electric Code and OSHA rules and regulations.
  9. All Goods must be installed in a stationery application, free of vibration.

A violation of any one of these conditions shall render the warranty hereunder void and of no effect.

- B. Exclusions. This warranty shall be void if product is misapplied in any way or:
1. Buyer specified product is inappropriate for system or environment in which it is operating.
  2. Pentair Equipment Protection product modified in any way without prior written authorization from Pentair Equipment Protection.
  3. Removal or modification of Pentair Equipment Protection label affixed to product without written Pentair Equipment Protection approval.

Pentair Equipment Protection must be notified of a claim in writing not later than fourteen (14) days from the date when Buyer has become aware of such occurrence, or where the defect is such that it may cause damage, immediately, such notice containing a description of how the defect manifests itself. Failure to provide such prompt notice to Pentair Equipment Protection shall result in forfeiture of Buyer's rights under this warranty.

In the event of a warranty claim, Buyer is to return defective goods to Pentair Equipment Protection in accordance with Pentair Equipment Protection Return Policy. Warranty period for repaired goods remains at 1 year from shipment of original goods. Pentair Equipment Protection sole obligation to Buyer under this warranty will be, at Pentair Equipment Protection option:

- A. Repair or replace Pentair Equipment Protection products or parts found to be defective in material or workmanship.
- B. Issue credit for the purchase price paid by Buyer relating to such defective Goods or part.

**THIS WARRANTY CONSTITUTES THE ENTIRE WARRANTY WITH RESPECT TO THE GOODS AND IS IN LIEU OF ALL OTHER WARRANTIES, EXPRESSED OR IMPLIED, INCLUDING ANY IMPLIED WARRANTY OF MERCHANTABILITY AND IMPLIED WARRANTY OF FITNESS FOR A PARTICULAR PURPOSE.**

## RETURN AND REPAIR POLICY

Pentair Equipment Protection products that: (i) are made to order, (ii) have been modified by Buyer, (iii) have special finishes, or (iv) are determined by Pentair Equipment Protection to constitute "custom" products that cannot be returned to stock or resold to other Buyers, will not be accepted for return by Pentair Equipment Protection.

All returns require a Return Material Authorization number (RMA #), regardless of reason for return, whether it be for warranty or out of warranty repair. Returns without an RMA # will be refused by our Receiving Department. An RMA # is valid for 60 days.

- A. An RMA # will be issued by our Repair Department in Anoka, MN at 866-545-5252. Buyer should have following information available at time of RMA request:
1. Complete Model Number, Serial Number and description of damaged unit being returned.
  2. Original Buyer Purchase Order number and date product was received by Buyer.
  3. Quantity to be returned and a brief description of failure for each unit, if different.

4. Contact information of Buyer that must include: name of company, billing and shipping address, phone, number, fax number, freight carrier and the name and phone number of a Buyer contact who can elaborate on the claimed defect in detail.
  5. Buyer must provide a Repair Purchase Order number for both warranty and out of warranty repairs. The PO will not exceed 50% of a new unit. Buyer will be notified of repair charges that exceed approved PO amount.
- B. All returns to Pentair Equipment Protection must be securely packed, using original cartons if possible. All returns must have the RMA number visible on the outside of the carton. Pentair Equipment Protection is not responsible for material damaged in transit. Any refrigerant-bearing Goods must be shipped upright for return.
  - C. Shipping cost for all non-warranty repairs is the responsibility of the sender and must be shipped prepaid. Shipping costs for all warranty related repairs will be covered by Pentair Equipment Protection provided the goods are returned using a Pentair Equipment Protection approved carrier. If after diagnosis the product is determined by Pentair Equipment Protection not be covered under warranty, Buyer will be responsible for all shipping charges and will be billed accordingly.
  - D. Non-warranty repairs are subject to a \$75 minimum analysis fee. Analysis fee will be waived if Buyer approves repair work. If approval is not received within 30 days, material will be scrapped and all shipping expenses and corresponding analysis fees will be billed to Buyer.
  - E. At Buyer's request, Failure Analysis can be provided by Pentair Equipment Protection for warrantable goods at no charge. Failure analysis for non-warranty repairs are subject to a \$100 per hour Engineering charge plus any other incurred testing costs.
  - F. All returned merchandise must be sent to the following address: Pentair Equipment Protection, 2100 Hoffman Way, Anoka, MN 55303-1745.
  - G. Credit for accepted returns shall be at the original selling price or the current selling price, whichever is lower, less the restocking charge indicated as follows:
    1. Within 60 days of invoice date - 20% of applicable selling price.
    2. Within 61-120 days of invoice date - 30% of applicable selling price.
    3. Within 121-180 days of invoice date - 40% of applicable selling price.
    4. Beyond 180 days - subject to individual review by Pentair Equipment Protection.If product being returned for credit requires repair or modification, the cost of any labor or material necessary to bring product into saleable condition will be deducted from credit. Buyer may not take credit against returns without prior written Pentair Equipment Protection approval.

## LIMITATION OF LIABILITY

Pentair Equipment Protection WILL NOT BE LIABLE UNDER ANY CIRCUMSTANCES FOR ANY INCIDENTAL, CONSEQUENTIAL OR SPECIAL DAMAGES, INCLUDING WITHOUT LIMITATION ANY LOST PROFITS OR LABOR COSTS, ARISING FROM THE SALE, USE OR INSTALLATION OF THE GOODS, FROM THE GOODS BEING INCORPORATED INTO OR BECOMING A COMPONENT OF ANOTHER PRODUCT, FROM ANY BREACH OF THIS AGREEMENT OR FROM ANY OTHER CAUSE WHATSOEVER, WHETHER BASED ON WARRANTY (EXPRESSED OR IMPLIED) OR OTHERWISE BASED ON CONTRACT, OR ON TORT OR OTHER THEORY OF LIABILITY, AND REGARDLESS OF ANY ADVICE OR REPRESENTATIONS THAT MAY HAVE BEEN RENDERED BY Pentair Equipment Protection CONCERNING THE SALE, USE OR INSTALLATION OF THE GOODS



Pentair Equipment Protection  
2100 Hoffman Way  
Minneapolis, MN 55303 USA  
☎ +1.763.422.2211  
📠 +1.763.576.3200

**[PentairEquipmentProtection.com](http://PentairEquipmentProtection.com)**