

# 9410 series

## User manual

7EN05-0336-03  
11/2017



# Safety information

## Important information

Read these instructions carefully and look at the equipment to become familiar with the device before trying to install, operate, service or maintain it. The following special messages may appear throughout this bulletin or on the equipment to warn of potential hazards or to call attention to information that clarifies or simplifies a procedure.



The addition of either symbol to a “Danger” or “Warning” safety label indicates that an electrical hazard exists which will result in personal injury if the instructions are not followed.



This is the safety alert symbol. It is used to alert you to potential personal injury hazards. Obey all safety messages that follow this symbol to avoid possible injury or death.

### **DANGER**

**DANGER** indicates a hazardous situation which, if not avoided, **will result in** death or serious injury.

### **WARNING**

**WARNING** indicates a hazardous situation which, if not avoided, **could result in** death or serious injury.

### **CAUTION**

**CAUTION** indicates a hazardous situation which, if not avoided, **could result in** minor or moderate injury.

### **NOTICE**

**NOTICE** is used to address practices not related to physical injury.

## Please note

Electrical equipment should be installed, operated, serviced and maintained only by qualified personnel. No responsibility is assumed by Siemens Industry for any consequences arising out of the use of this material. A qualified person is one who has skills and knowledge related to the construction, installation, and operation of electrical equipment and has received safety training to recognize and avoid the hazards involved.

---

# Notices

## FCC

This equipment has been tested and found to comply with the limits for a Class B digital device, pursuant to part 15 of the FCC rules. These limits are designed to provide reasonable protection against harmful interference in a residential installation. This equipment generates, uses, and can radiate radio frequency energy and, if not installed and used in accordance with the instructions, may cause harmful interference to radio communications. However, there is no guarantee that the interference will not occur in a particular installation. If this equipment does cause harmful interference to radio or television reception, which can be determined by turning the equipment off and on, the user is encouraged to try to correct the interference by one or more of the following measures:

- Reorient or relocate the receiving antenna.
- Increase the separation between the equipment and receiver.
- Connect the equipment to an outlet on a circuit different from that to which the receiver is connected.
- Consult the dealer or an experienced radio/TV technician for help.

The user is cautioned that any changes or modifications not expressly approved by Siemens Industry could void the user's authority to operate the equipment.

This digital apparatus complies with CAN ICES-3 (B) /NMB-3(B).

## About this manual

This manual discusses features of the 9410 series power meter and provides installation and configuration instructions.

Throughout the manual, the term "meter" refers to all models of the 9410. All differences between the models, such as a feature specific to one model, are indicated with the appropriate model number or description.

This manual assumes you have an understanding of power metering and are familiar with the equipment and power system in which your meter is installed.

This manual does not provide configuration information for advanced features where an expert user would perform advanced configuration. It also does not include instructions on how to incorporate meter data or perform meter configuration using energy management systems or software, other than ION Setup.

ION Setup is a free configuration tool available for download from [www.usa.siemens.com/pds](http://www.usa.siemens.com/pds). It is recommended that you always upgrade to the latest version of ION Setup to help properly configure the features available on your meter.

Please contact your local Siemens Industry representative to learn what additional training opportunities are available regarding the 9410 meter.

Make sure you are using the most up-to-date version of your meter's firmware in order to access the latest features.

The most up-to-date documentation about your meter is available for download from [www.usa.siemens.com/pds](http://www.usa.siemens.com/pds).

**Related documents**

<b>Document</b>	<b>Number</b>
9410DC / 9410D24VDC installation sheet	NVE23944
9410TC and 9410T24VDC installation sheet	NVE23945
ION Reference	70005-0290
ION device template reference	—

# Table of Contents

Safety precautions.....	11
Meter overview.....	12
9410 overview .....	12
Your meter in an energy management system .....	12
Measured parameters .....	13
Localization .....	15
Data display and analysis tools .....	15
Supported protocols .....	16
ION Setup device configuration tool.....	16
Meter types.....	16
Mounting adaptors .....	17
Terminal covers.....	17
Replacement hardware.....	17
Basic setup .....	18
Default values for commissioning .....	18
Meter setup .....	18
Minimum configuration requirements for basic metering .....	19
Hardware reference .....	20
Supplemental information .....	20
Meter base .....	20
Remote meter display (RMD).....	21
Mounting adaptors .....	22
Terminal covers.....	22
Replacement hardware.....	22
LED locations .....	22
Energy pulsing LED behavior.....	23
Revenue lock LED behavior.....	23
Remote display connection LED behavior .....	23
Panel-mount meter and remote display mounting and wiring recommendations .....	24
Power system wiring .....	24
RS-485 wiring .....	24
Ethernet communications connections.....	25
Option modules overview.....	25
Maximum number of option modules .....	25
Meter display .....	27
Display overview .....	27
Display menu.....	30
Setup menu .....	34
Using the onscreen keyboard .....	37
Remote display troubleshooting icons.....	39
Creating custom displays using ION Setup.....	40
Security .....	42
Security overview .....	42

Security features on your device.....	42
Network port control.....	42
Enable/disable communication ports.....	42
Revenue and billing security features.....	43
Event logging.....	43
Syslog.....	43
Advanced security through the meter's display.....	43
NERC CIP.....	43
Security recommendations and best practices.....	44
Password best practices.....	44
Standard and advanced security features.....	45
Security configuration process.....	45
Communications protocol lockout overview.....	46
Password setup.....	47
Advanced security username and password through the display.....	47
Changing your meter's display password using the display.....	47
Configuring standard security using ION Setup.....	48
Configuring users and passwords using ION Setup (advanced security only).....	49
Loading an existing security configuration file (.scf) using ION Setup.....	50
<b>Communications.....</b>	<b>51</b>
Communications overview.....	51
ION.....	70
Modbus.....	71
Your meter as a Modbus slave.....	73
Your meter as a Modbus master.....	74
Ethernet gateway.....	79
FTP.....	83
IEC 61850.....	90
DNP.....	92
<b>Time and timekeeping.....</b>	<b>94</b>
Time overview.....	94
Internal clock temperature compensation.....	94
Internal clock temperature compensation parameters.....	94
Time synchronization overview.....	94
Supported time synchronization sources.....	95
GPS time quality flag.....	95
Configuring time information using your meter's display.....	96
Configuring time and time synchronization using ION Setup.....	97
<b>Maintenance.....</b>	<b>99</b>
Firmware and templates.....	99
Device-specific information.....	105
Troubleshooting.....	106
Technical assistance.....	106
<b>Meter webpages.....</b>	<b>107</b>
Webpage interface.....	107
Default meter webpages.....	108

Accessing the meter's webpages for data viewing and meter configuration .....	109
Viewing files using your meter's webpages .....	110
Creating custom webpages for your meter .....	110
Sample data viewing webpage .....	111
<b>Logging .....</b>	<b>119</b>
Logging overview .....	119
Data logging overview .....	119
Event log overview .....	120
User triggered event log entries .....	120
Assigning a designated reader for event log notification.....	120
Syslog overview .....	121
Waveform recording overview .....	122
Default logging framework .....	124
Advanced log setup and memory optimization .....	129
Viewing log configuration and memory usage information.....	129
Log depth configuration.....	130
Log interval configuration .....	130
Log mode configuration.....	130
Log buffer configuration .....	131
Changing log interval and depth settings using ION Setup .....	133
Data log memory calculations.....	134
Waveform record memory calculations.....	134
<b>Inputs / outputs .....</b>	<b>135</b>
I/O Overview.....	135
Input/output ION modules .....	135
Input/output ION modules, ports and labels .....	135
I/O option modules .....	136
Option I/O modules configuration.....	137
Analog inputs.....	138
Analog outputs.....	140
Digital inputs.....	141
IRIG-B time synchronization .....	141
WAGES monitoring .....	143
Input metering .....	144
Digital outputs.....	146
Energy pulsing.....	148
<b>Alarms and alerts.....</b>	<b>150</b>
Alarms overview.....	150
Alarm types .....	150
Relative setpoint .....	152
Alarm event priorities.....	152
Alarm indicators .....	153
Default alarms .....	154
Alarm information.....	154
Viewing and acknowledging alarms using the meter's display .....	155
Alarm configuration .....	155

Alerting.....	159
Setpoint learning overview .....	160
Learning installation mode and learning duration .....	160
<b>Resets .....</b>	<b>164</b>
Meter resets .....	164
Option module reset .....	164
Available resets .....	164
<b>Measurements .....</b>	<b>168</b>
Power and power factor .....	168
Power demand.....	170
WAGES monitoring .....	171
Incremental energy .....	172
Conditional energy .....	173
Trending and forecasting overview .....	174
<b>Power quality.....</b>	<b>176</b>
Power quality overview .....	176
Sag/swell overview.....	176
Harmonics overview.....	176
Voltage crest factor.....	177
Crest factor current.....	177
K-factor .....	177
Harmonic content calculations.....	178
TDD calculations.....	178
thd and TDD .....	178
Phasors.....	178
Disturbance direction detection overview .....	179
COMTRADE.....	180
COMTRADE implementation overview.....	180
Waveforms on your meter's webpages .....	181
<b>Verifying accuracy .....</b>	<b>184</b>
Overview of meter accuracy.....	184
Accuracy test requirements.....	184
Energy pulsing.....	185
Verifying accuracy test meter settings .....	185
Verifying accuracy test.....	186
Calculate the number of required pulses .....	187
Percentage error calculation for accuracy verification testing .....	188
Typical sources of test errors.....	188
Accuracy verification test points .....	188
<b>Revenue metering .....</b>	<b>190</b>
Revenue metering overview.....	190
Components of revenue metering.....	190
Revenue firmware security features.....	190
Protected features and settings .....	190
Revenue meter pre-installation procedure.....	190
Revenue locking .....	191
Revenue lock switch.....	191

---

Revenue locking your meter.....	192
PT/CT correction .....	192
Time of use.....	193
<b>Specifications overview .....</b>	<b>194</b>
Mechanical characteristics .....	194
Electrical characteristics .....	194
Environmental characteristics .....	196
LEDs.....	197
EMC (electromagnetic compatibility).....	197
Safety .....	198
Ethernet communications .....	198
RS-485 communications.....	198
Real-time clock .....	198
MID.....	198
Remote display .....	199
Option modules.....	199
Other.....	199



# Safety precautions

Installation, wiring, testing and service must be performed in accordance with all local and national electrical codes.

## **⚠ DANGER**

### **HAZARD OF ELECTRIC SHOCK, EXPLOSION, OR ARC FLASH**

**Failure to follow these instructions will result in death or serious injury.**

- Apply appropriate personal protective equipment (PPE) and follow safe electrical work practices. See NFPA 70E in the USA, CSA Z462 or applicable local standards.
- Turn off all power supplying this device and the equipment in which it is installed before working on the device or equipment.
- Always use a properly rated voltage sensing device to confirm that all power is off.
- Treat communications and I/O wiring connected to multiple devices as hazardous live until determined otherwise.
- Do not exceed the device's ratings for maximum limits.
- Never short the secondary of a potential/voltage transformer (PT/VT).
- Never open circuit a current transformer (CT).
- Always use grounded external CTs for current inputs.
- Do not use the data from the meter to confirm power is off.
- Replace all devices, doors and covers before turning on power to this equipment.

**NOTE:** See IEC 60950-1:2005, Annex W for more information on communications and I/O wiring connected to multiple devices.

## **⚠ WARNING**

### **UNINTENDED OPERATION**

**Failure to follow these instructions can result in death, serious injury, or equipment damage.**

Do not use this device for critical control or protection applications where human or equipment safety relies on the operation of the control circuit.

## **⚠ WARNING**

### **POTENTIAL COMPROMISE OF SYSTEM AVAILABILITY, INTEGRITY, AND CONFIDENTIALITY**

**Failure to follow these instructions can result in death, serious injury, or equipment damage.**

- Change default passwords to help prevent unauthorized access to device settings and information.
- Disable unused ports/services and default accounts, where possible, to minimize pathways for malicious attacks.
- Place networked devices behind multiple layers of cyber defenses (such as firewalls, network segmentation, and network intrusion detection and protection).
- Use cybersecurity best practices (for example: least privilege, separation of duties) to help prevent unauthorized exposure, loss, modification of data and logs, interruption of services, or unintended operation.

# Meter overview

## 9410 overview

The 9410 series power and energy meters help meet the needs of your energy monitoring and cost management applications.

All 9410 meters comply with international metering accuracy standards. You can customize your meter by loading specialized frameworks, and adding option modules and incorporating mounting accessories into the physical installation.

### Meter features

True RMS metering to the 63rd harmonic
Active (kW), reactive (kVAR) and apparent (kVA) power
600 V direct connection on voltage inputs
Minimum/maximum readings of metered data
Power quality readings (THD)
Downloadable firmware and template
Configuration through integrated or remote display
Modbus master, Ethernet gateway protocols supported
Web interface
Sag/Swell capture for voltage and currents
Time synchronization to 1 ms accuracy
Dual port Ethernet (two physical ports, one Ethernet IP address)
Water Air Gas Electricity Steam (WAGES) support
Time of use support
Trending and forecasting
Alarms (active and historic) display viewing and acknowledgment
Multiple languages supported
Advanced security
Variety of industry-standard communications protocols supported

## Your meter in an energy management system

As a key piece in your energy management system, the meter provides highly accurate measurements and calculations for a wide variety of power system values, performs analysis on collected data, alerts you of potential issues and integrates with a variety of display and analysis software.

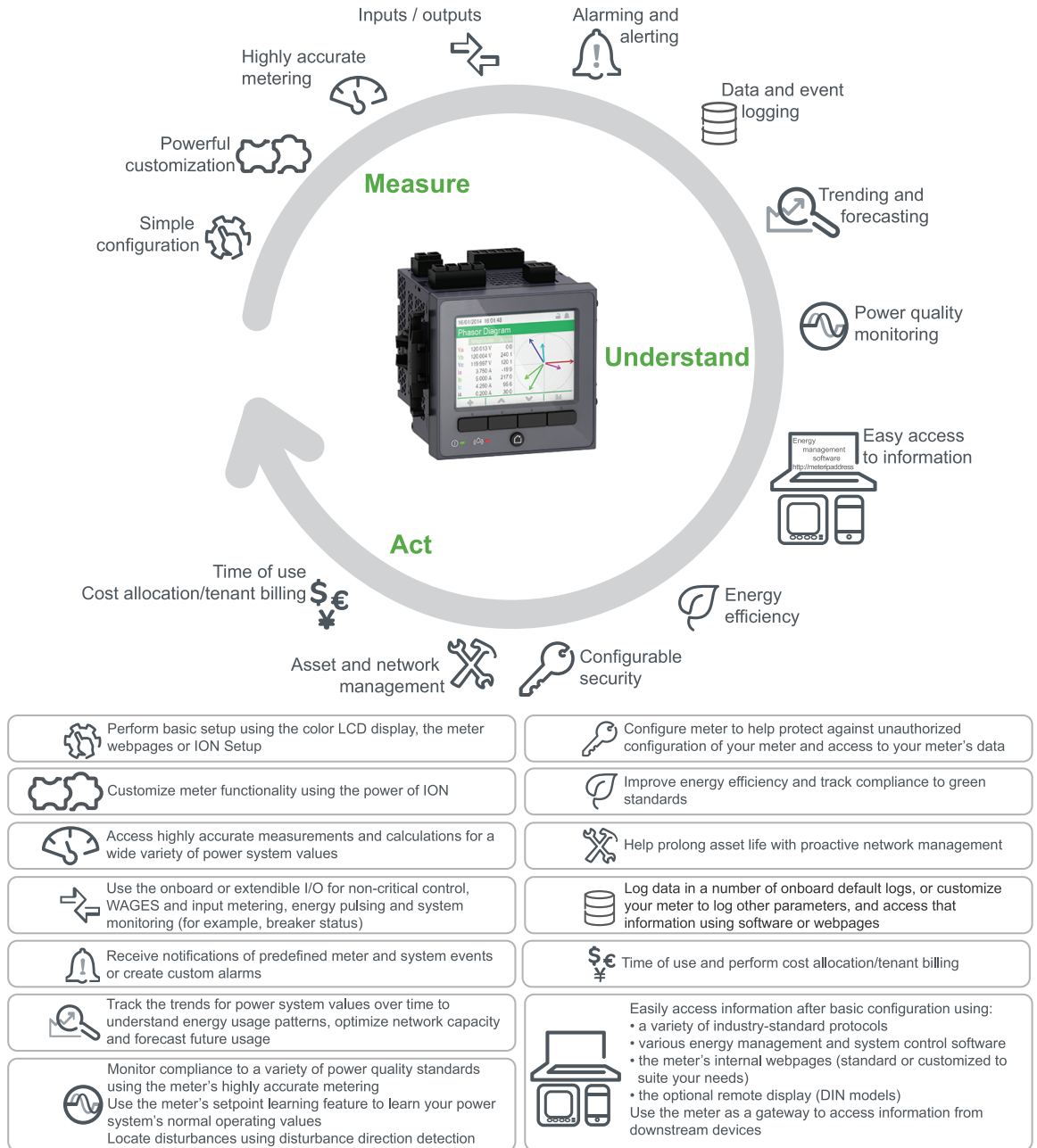

## Measured parameters

### Energy

Your meter provides bi-directional 4-quadrant energy metering.

Your meter provides active, reactive and apparent energy values.

- kWh, kVARh, kVAh delivered and received
- kWh, kVARh, kVAh net (delivered - received)
- kWh, kVARh, kVAh total (delivered + received)
- Volt-squared-hours and amp-squared-hours

Energy parameters can be logged automatically on a programmed schedule.

All energy values represent the total for all three phases.

## Demand

Your meter supports several demand calculation methods, including block, rolling block, synchronized and predicted demand.

It can measure demand on any instantaneous value and record peak (maximum) and minimum demand with time and date information.

- kW, kVAR, kVA demand
- kW, kVAR, kVA peak demand
- Amps, Volts demand

## Instantaneous

Your meter provides one second and half-cycle measurements, per phase and totals for many values.

- Voltage and current
- Apparent power (kVA), active power (kW) and reactive power (kVAR)
- Power factor and frequency
- Voltage and current unbalance

## Harmonics

Your meter provides harmonic distortion metering, recording and real-time values for all voltage and current inputs.

- Individual harmonics (including magnitude and phase angle) up to the 63<sup>rd</sup> harmonic
- Total even harmonic distortion (TEHD) and total odd harmonic distortion (TOHD)
- Total harmonic distortion (THD) or total demand distortion (TDD)
- K-factor, Crest factor

## Min/max recording

Your meter records new minimum and maximum data every recording interval for a variety of values.

- Voltage and current
- kW, kVAR and kVA
- Power factor
- Frequency
- Voltage unbalance
- Plus any measured value

## Power quality

Your meter measures and records voltage and current sags and swells.

Your meter also has many power quality related features.

- Disturbance direction detection: this allows the meter to analyze disturbance (sag/swell) information to help determine the direction of the disturbance relative to the meter.
- Setpoint learning: this allows the meter to learn the power quality characteristics of your system, to help identify what constitutes a sag or a swell.

- COMTRADE: this allows the meter to save waveform data in COMMon format for TRANsient Data Exchange (COMTRADE) on its internal FTP server.

Your meter includes the following power quality compliance:

- EN50160: Your meter measures and presents statistics for determining EN50160 compliance.
- IEC 61000-4-30: Your meter complies with the IEC 61000-4-30 power quality standard.
- IEC 62586: Your meter complies with the IEC 62586 power quality standard.

## Localization

The meter can be customized to use different regional settings.

Localization settings determine:

- The language used for the display and webpages
- Time, date and digit formats
- Displayed phase labels (123/ABC)
- IEEE (Institute of Electrical and Electronics Engineers) or IEC (International Electrotechnical Commission) conventions for power, power factor and energy

You can configure your meter's localization settings through the display or using ION Setup.

## Data display and analysis tools

### Display

Use the meter's display for local monitoring and standalone applications.

The color LCD display lets you view real-time values, events and alarms, and perform basic device configuration. Connect a remote display to a meter without an integrated display to view meter data and perform basic meter configuration.

### Active and historical alarms

The meter's display shows an alarm icon and the alarm LED flashes if your meter detects an active alarm condition.

Depending on the priority of the alarm, your meter's display also flashes. You can view and acknowledge active alarms and historic alarms and events through the display and software webpages. An active alarm becomes a historic alarm when the alarm condition no longer exists.

### Meter internal web server feature

Your meter's internal web server provides quick and easy access to real-time energy and basic power quality information without special software using an on-board web server combined with an Ethernet port.

The built-in web pages display selected energy and power quality information through the web-enabled device; these pages also support basic meter configuration.

## Email messaging feature

You can configure your meter to automatically email information, whether notification of a high-priority event or a regularly scheduled send of logged data, to an external email address.

Specify the type of event that triggers an email alert, such as a power quality disturbances or interval for logged data. Email messages from your meter are received like any other email message.

## Supported protocols

Your meter's fundamental protocol and architecture is ION.

You can integrate the meter into various industry-standard networks. Data that the meter measures can be made available to other devices using Modbus, DNP 3.0 and SNMP as well as the MV-90 translation system. You can configure the meter to import data from other devices on these networks. Your meter supports the IEC 61850 protocol and COMTRADE waveform data format.

Your meter also supports IPv6, DPWS and RSTP Ethernet protocols.

### Related Topics

- Protocols, ports and connections

## ION Setup device configuration tool

ION Setup is a free configuration tool for your meter that allows you to remotely configure your meter's features over Ethernet or serial communications.

- Use the setup screens to guide you through the process of configuring your meter.
- Use the real-time data screens to verify your meter's configuration.
- Use the data screens to view your meter's recorded data.
- Use the charting function to view your meter's recorded waveforms.

You can download ION Setup from [www.usa.siemens.com/pds](http://www.usa.siemens.com/pds).

See the online ION Setup help, available from [www.usa.siemens.com/pds](http://www.usa.siemens.com/pds), for instructions on connecting to your meter.

## Meter types

The 9410 series is available in two physical form factors, and has several accessories.

Model	Commercial reference	Description
9410DC	US2:9410DC	Panel-mounted meter with integrated display
9410D24VDC	US2:9410D24VDC	Same as the 9410DC, except with low-voltage DC control power
9410TC	US2:9410TC	DIN rail-mounted meter without display, which can be connected to a remote display
9410T24VDC	US2:9410T24VDC	Same as the 9410TC, except with low-voltage DC control power
9410RC	US2:9410RC	DIN rail-mounted meter packaged with a remote display

Model	Commercial reference	Description
9410RVDC	US2:9410R24VDC	Same as the 9410TC, except with low-voltage DC control power
948DISP96	US2:948DISP96	Remote display (for DIN meter only)
948M2DO6DI	US2:948M2DO6DI	Digital I/O option module (2 outputs, 6 inputs)
948M2AO4AI	US2:948M2AO4AI	Analog I/O option module (2 outputs, 4 inputs)
9410SK	US2:9410SK	Voltage and current sealing kit
94PMAK	94PMAK	Mounting adapter kit for remote display and DIN meter

## Mounting adaptors

There are different mounting adaptor accessories that can help when installing your meter in existing panels and cutouts where the default mounting hardware is not appropriate.

Mounting adaptor kits are ordered separately from the meter.

## Terminal covers

The voltage and current terminal covers help prevent tampering with the meter's voltage and current measurement inputs.

The terminal covers enclose the terminals, the conductor fixing screws and a length of the external conductors and their insulation. The terminal covers are secured by tamper-resistant meter seals.

These covers are included for meter models where sealable voltage and current covers are required to comply with revenue or regulatory standards.

The meter terminal covers must be installed by a qualified installer.

Refer to your meter's installation sheet or the instructions that came with your terminal covers for instructions on installing the terminal covers.

## Replacement hardware

You can order replacement mounting and installation hardware for your meter and accessories.

# Basic setup

## Default values for commissioning

Use these default settings for the first time you connect to and configure your meter.

Parameter	Default value
Display password (also for logging onto meter webpages)	0
Username (for logging onto meter webpages)	9410
IP address	169.254.0.10
Subnet mask	255.255.0.0
Gateway	0.0.0.0
Unit ID	1
Language	English

## Meter setup

You can configure your meter's basic metering parameters using the display.

### Volts mode

Parameter	Values	Description
Volts Mode	4W-Wye, Delta, 3W-Wye, Single, Demo	The power system's configuration
PhaseOrder	ABC, ACB	The power system's phase order

### PT/CT setup

Parameter	Values	Description
PT Primary	1 to 999,999.99	The potential transformer's primary winding voltage rating <b>NOTE:</b> PTs are also referred to as a VTs or voltage transformers.
PT Secondary	1 to 999,999.99	The potential transformer's secondary winding voltage rating <b>NOTE:</b> PTs are also referred to as a VTs or voltage transformers.
CT Primary	1 to 999,999.99	The current transformer's primary winding current rating
CT Secondary	1 to 999,999.99	The current transformer's secondary winding current rating
I4 Primary	1 to 999,999.99	The I4 current transformer's primary winding current rating
I4 Secondary	1 to 999,999.99	The I4 current transformer's secondary winding current rating

## Voltage polarity setup

Parameter	Values	Description
Va Polarity	Normal, Inverted	The polarity of the potential transformer on Va
Vb Polarity	Normal, Inverted	The polarity of the potential transformer on Vb
Vc Polarity	Normal, Inverted	The polarity of the potential transformer on Vc

## Current polarity setup

Parameter	Values	Description
Ia Polarity	Normal, Inverted	The polarity of the current transformer on Ia
Ib Polarity	Normal, Inverted	The polarity of the current transformer on Ib
Ic Polarity	Normal, Inverted	The polarity of the current transformer on Ic
I4 Polarity	Normal, Inverted	The polarity of the current transformer on I4

## Nominal values

Parameter	Values	Description
V Nominal	1 to 999,999	The nominal (normal) voltage of the power system
I Nominal	1 to 999,999	The nominal (normal) current of the power system
Nominal Frequency	50, 60	The nominal (normal) frequency of the power system

## Minimum configuration requirements for basic metering

At a minimum, you must configure some parameters to help your meter perform basic metering functions.

Setup screen	Screen	Minimum configuration
Meter Setup	Volts Mode	Volts mode
	PT/CT Setup	PT, CT and I4 CT primary and secondary
	Nominal values	V nominal, I nominal, Nominal frequency

**NOTE:** You must also configure all the parameters related to the meter features you are using, for example, you must configure the DNS server address if you are using the meter's DNS feature.

# Hardware reference

## Supplemental information

This document is intended to be used in conjunction with the installation sheet that ships in the box with your meter and accessories.

See your device's installation sheet for information related to installation.

See your product's catalog pages at [www.usa.siemens.com/pds](http://www.usa.siemens.com/pds) for information about your device, its options and accessories.

You can download updated documentation from [www.usa.siemens.com/pds](http://www.usa.siemens.com/pds) or contact your local Siemens Industry representative for the latest information about your product.

## Meter base

Your meter base has two form factors, panel mount and DIN mount.

### Panel meter

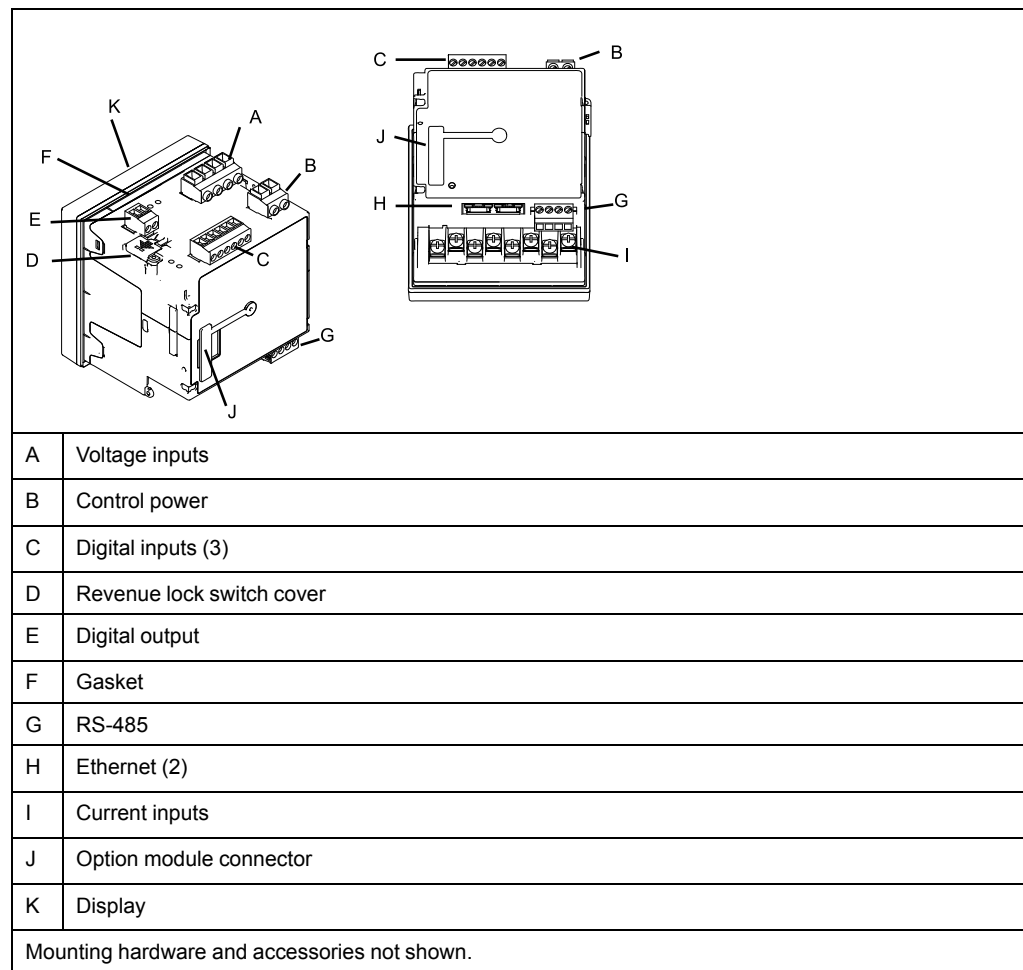

## DIN meter

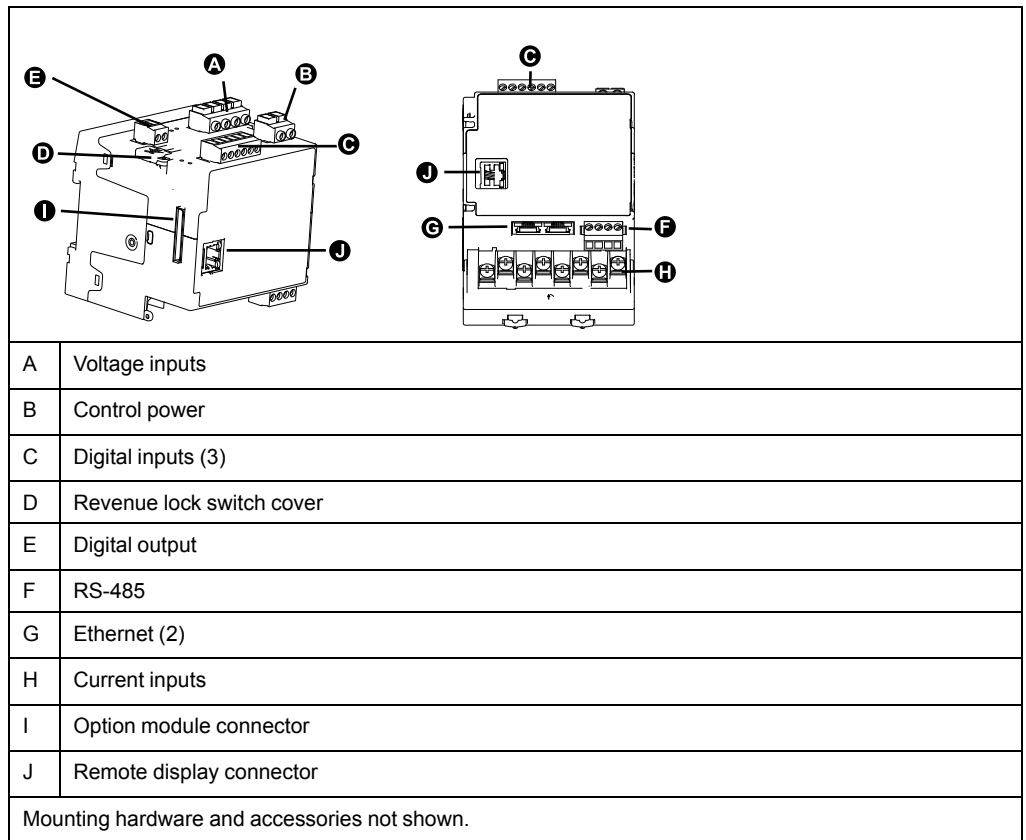

See the 9410 catalog pages, available from [www.usa.siemens.com/pds](http://www.usa.siemens.com/pds), or consult your local Siemens Industry representative for information about your device, its options and accessories.

## Remote meter display (RMD)

The remote meter display can be used with DIN meters.

It has the same buttons and icons as the display on a panel meter, and is powered by the connection to the meter. A remote display cannot be used with meters that have an integrated display

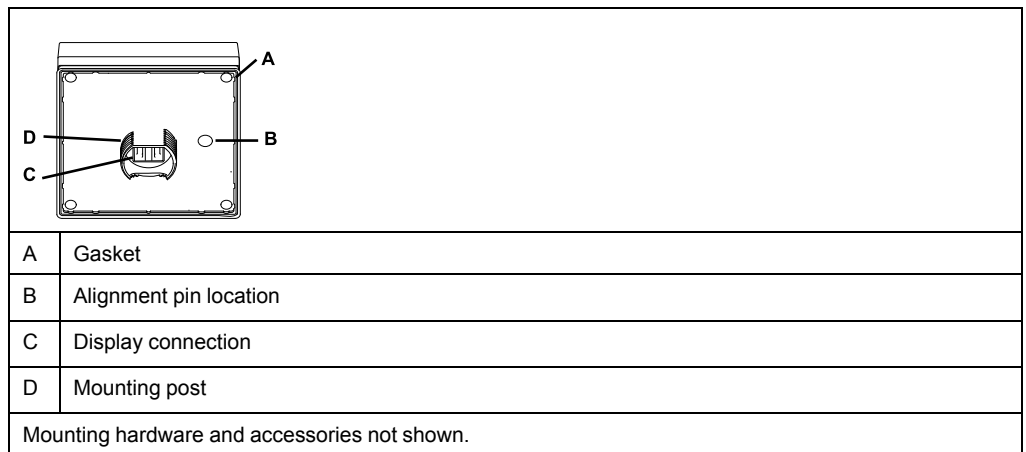

## Mounting adaptors

There are different mounting adaptor accessories that can help when installing your meter in existing panels and cutouts where the default mounting hardware is not appropriate.

Mounting adaptor kits are ordered separately from the meter.

## Terminal covers

The voltage and current terminal covers help prevent tampering with the meter's voltage and current measurement inputs.

The terminal covers enclose the terminals, the conductor fixing screws and a length of the external conductors and their insulation. The terminal covers are secured by tamper-resistant meter seals.

These covers are included for meter models where sealable voltage and current covers are required to comply with revenue or regulatory standards.

The meter terminal covers must be installed by a qualified installer.

Refer to your meter's installation sheet or the instructions that came with your terminal covers for instructions on installing the terminal covers.

## Replacement hardware

You can order replacement mounting and installation hardware for your meter and accessories.

## LED locations

The LED indicators alert or inform you of meter activity.

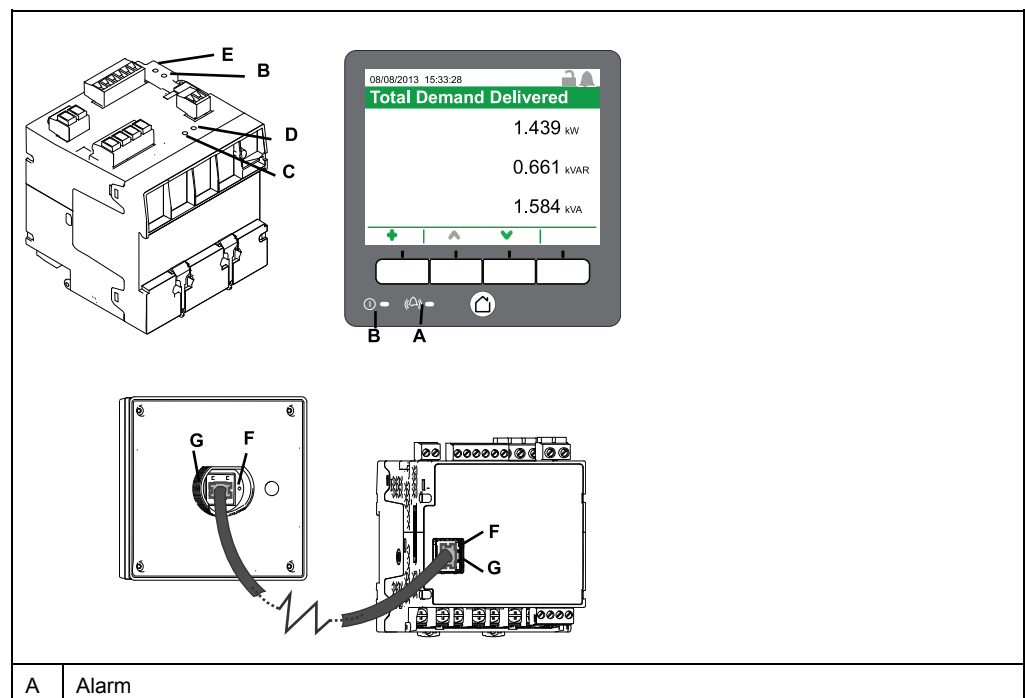

B	Status
C	Energy pulsing
D	Infrared energy pulsing
E	Revenue lock status
F	Remote display connection link
G	Remote display connection activity

### Related Topics

- Alarm and status LED indicators

## Energy pulsing LED behavior

The visible and infrared LEDs are configured by default to pulse based on energy measured by the meter.

You can configure the pulse weight (pulses per kWh) and the energy source.

Energy pulsing is used to help verify the energy measurement accuracy of your meter for revenue purposes.

### Related Topics

- Energy pulsing

## Revenue lock LED behavior

The revenue lock LED indicates the lock status of the meter.

State	Description
Off	The meter is not revenue locked.
On	The meter is revenue locked.
Flashing	New revenue lock state is pending; power cycle your meter to set the revenue lock to on or off.

## Remote display connection LED behavior

There are two LEDs in the remote display connector that indicate the state of communications between the meter and remote display.

LED	Description
Green (link)	On: link established. Off: no link established with the remote display. Check the connections to the remote display and DIN meter.
Yellow (activity)	Flashing: active communications between the meter and the remote display. Off: no communication activity. Check remote display and meter operation.

## Panel-mount meter and remote display mounting and wiring recommendations

There are supplemental mounting and wiring recommendations that apply to panel-mount meters and remote displays.

- The meter is intended to be mounted inside a ¼-DIN panel cutout.
- Inspect the gasket (installed around the perimeter of the display) and make sure it is secured properly and not damaged.
- The meter retainer clips, located on either side of the meter base and used to secure the meter in the panel, do not usually require any tools to install. If necessary, for panels with limited space, you can use a long-handled slot screwdriver to help install the meter retainer clips.
- The remote display can only be used with the DIN meter; it cannot be used by meters with an integrated display.
- The remote display's power and communications is provided through a single, direct, point-to-point connection from the remote display to the DIN meter.

## Power system wiring

You can connect the meter's voltage inputs directly to the phase voltage lines of the power system if the power system's line-to-line or line-to-neutral voltages do not exceed the meter's direct connect maximum voltage limits.

The maximum voltage allowed for direct connection may be lower than the manufacturer-specified limits, depending on the local electrical codes and regulations.

If your system voltage is greater than the specified direct connect maximum voltage, you must use voltage (potential) transformers (VTs/PTs) to step down the voltages.

## RS-485 wiring

Connect the devices on the RS-485 bus in a point-to-point configuration, with the (+) and (-) terminals from one device connected to the corresponding (+) and (-) terminals on the next device.

### RS-485 cable

Use a shielded 2 twisted pair or 1.5 twisted pair RS-485 cable to wire the devices. Use one twisted pair to connect the (+) and (-) terminals, and use the other insulated wire to connect the C terminals

The total distance for devices connected on an RS-485 bus should not exceed 1200 m (4000 ft).

### RS-485 terminals

C	Common. This provides the voltage reference (zero volts) for the data plus and data minus signals
	Shield. Connect the bare wire to this terminal to help suppress signal noise that may be present. Ground the shield wiring at one end only (either at the master or the last slave device, but not both).
-	Data minus. This transmits/receives the inverting data signals.
+	Data plus. This transmits/receives the non-inverting data signals.

**NOTE:** If some devices in your RS-485 network do not have the C terminal, use the bare wire in the RS-485 cable to connect the C terminal from the meter to the shield terminal on the devices that do not have the C terminal.

## Ethernet communications connections

Your meter's dual port Ethernet connections enable you to use straight-line or network loop (ring) topologies.

If local network loop Ethernet topologies are required, you must enable RSTP for your meter's Ethernet communications to function.

Only use CAT5/5e/6/6a Ethernet cables to wire your meter's Ethernet communications.

## Option modules overview

Option modules are ordered separately from your meter, and can be connected to your meter without specialized equipment.

Option modules are identified based on the physical order of the attached modules. The option module attached directly to the meter is module A, the module attached to module A is module B, and so on. The option module identifier is added to the ION module name and ION label to uniquely describe each possible combination of option modules.

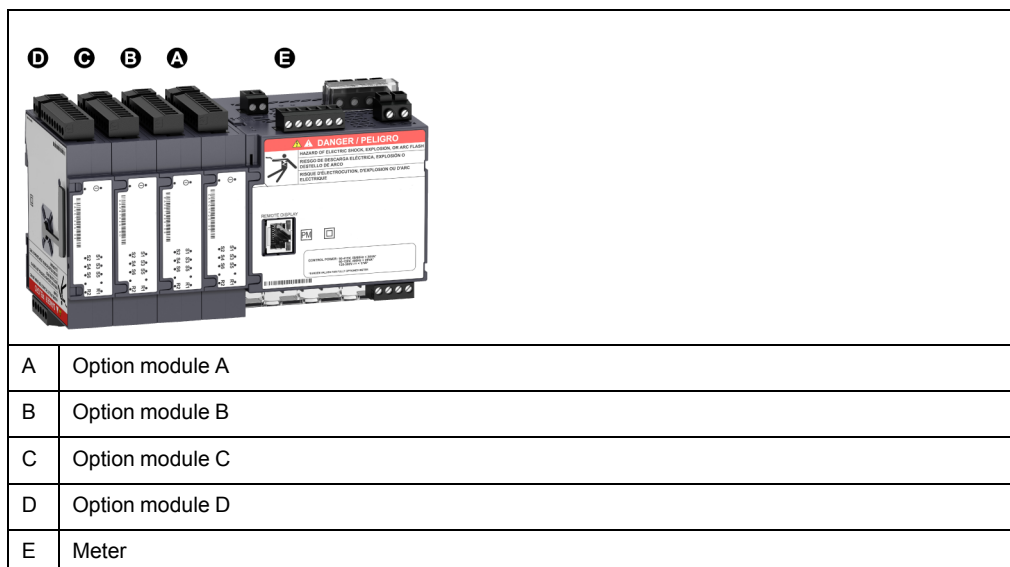

For example, a meter with two option modules, consisting of an analog option module directly attached to the meter (A) and a digital option module attached second (B), describes the Q2 analog output of module A as Port A Q2 and the S3 digital input of module B as Port B S3.

## Maximum number of option modules

The maximum number of option modules supported by the device is four. However, there are limitations.

Depending on the type and quantity of option modules attached to your meter, you may need to reduce your meter's maximum operating temperature or limit the number

of option modules. Refer to *Maximum operating temperature, page 197* for more information.

For a panel mount meter, one limitation on the number of modules that can be attached is the physical strength of the meter mounting hardware. If your meter is mounted in an area subject to vibration or other physical stresses, your meter's ability to physically support multiple option modules and maintain a seal against the mounting surface may be affected. Refer to *Mechanical characteristics, page 194* for more information.

## ***NOTICE***

### **EQUIPMENT DAMAGE**

**Failure to follow these instructions can result in equipment damage.**

Do not exceed the maximum number of option modules.

# Meter display

## Display overview

The display allows you to view meter data and perform basic configuration.

Your meter can have either an integrated or an optional remote display. The integrated and remote display screens have the same meter data and setup screens. Only meters without an integrated display can use the remote display.

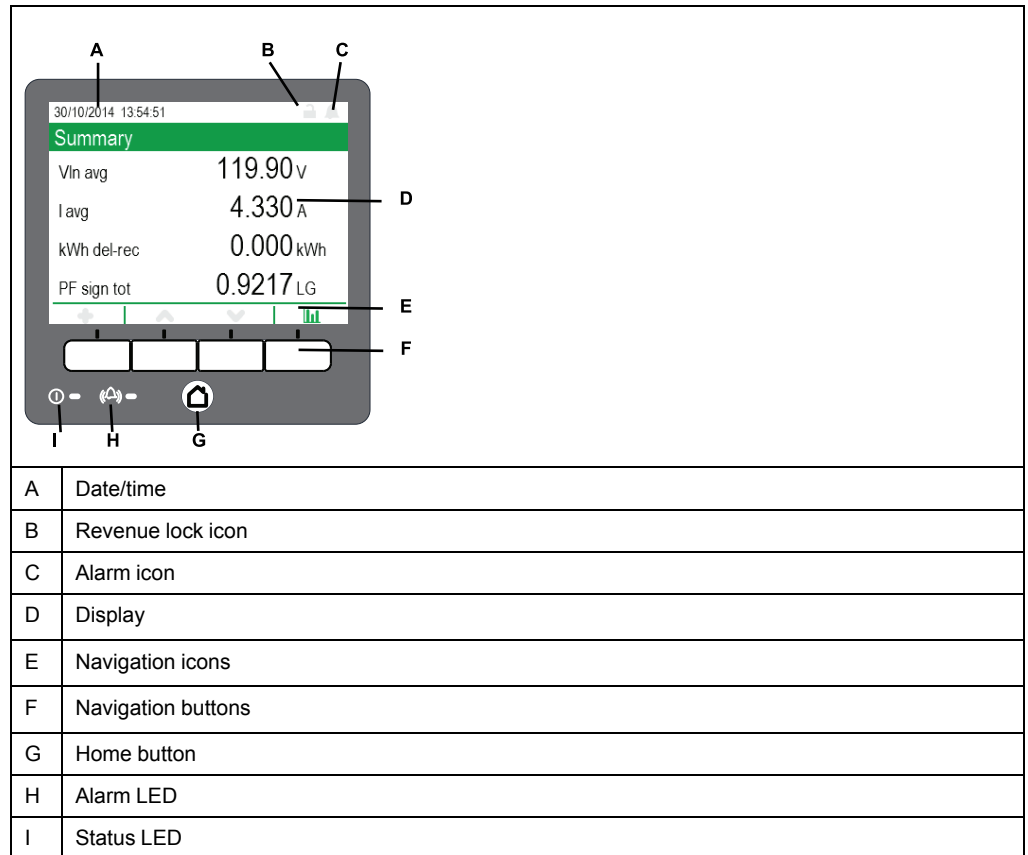

**NOTE:** Your meter's display backlight dims after a defined period of inactivity. When the meter detects an unacknowledged active high priority alarm, the display flashes until the alarm is acknowledged.

### Home button

Pressing the home button takes you to the associated menu screen. If you are in a data screen, pressing the home button takes you to the display menu, and pressing home twice takes you to the summary display screen. If you are in a setup screen, pressing home takes you to the setup menu, and pressing home again takes you to the display menu.

### Revenue lock icon

The revenue lock icon indicates the lock status of the meter.

When gray and open, the meter is unlocked. When green and closed, the meter is locked. You can lock and unlock your meter using the revenue lock switch located on the body of your meter.

## Related Topics



- Revenue locking

## Alarm icon

The alarm icon indicates the highest level and state of alarms detected by your meter.

For example, if the meter detects a low priority and a high priority active alarm, the alarm icon indicates a high priority active alarm.

**NOTE:** Alarms can only be viewed and acknowledged through your meter's display.

Icon	Description
	<p>Active alarm indicator:</p> <ul style="list-style-type: none"> <li>• Red: high priority alarm state detected</li> <li>• Yellow: medium priority alarm state detected</li> <li>• Blue: low priority alarm state detected</li> </ul> <p>The alarm indicator flashes until you acknowledge the alarm.</p> <p>The alarm indicator changes to the historic alarm indicator of the appropriate level when the alarm state is no longer detected by the meter.</p> <p><b>NOTE:</b> Your meter's display backlight flashes for unacknowledged high priority active alarms.</p>
	<p>Unacknowledged historic alarm indicator:</p> <ul style="list-style-type: none"> <li>• Red: unacknowledged high priority historic alarm</li> <li>• Yellow: unacknowledged medium priority historic alarm</li> </ul> <p><b>NOTE:</b> Low priority historical alarms are not indicated.</p> <p>The active alarm indicator changes to the historic alarm indicator of the appropriate level when the alarm state is no longer detected by the meter.</p>
	No active or unacknowledged high or medium priority historic alarms

## Related Topics

- Alarms overview

## Alarm and status LED indicators

Your meter has alarm and status LEDs on the display.

These LEDs cannot be configured for other uses.

LED	Description
Status	<p>Off: unpowered</p> <p>Steady green: normal operation</p> <p>Flashing red: no communications (remote display only)</p> <p>Steady red: firmware upgrade required (remote display only)</p> <p>Flashing red/green: startup or firmware upgrade sequence in progress</p>
Alarm	<p>Off: no active or unacknowledged historic alarms</p> <p>On: acknowledged active alarm</p> <p>Flashing: active alarm</p> <p><b>NOTE:</b> Your meter's display backlight flashes for unacknowledged high priority active alarms.</p>













## Related Topics

- LED locations

## Navigation symbols

Navigation symbols are displayed on the bottom of the screen above their corresponding navigation button.

**NOTE:** If the symbol is gray, that navigation function is not available.

Symbol	Description
	More Pressing this button displays additional screens.
	Left Pressing this button moves the displayed cursor one position to the left. If you are in a more or info screen, it returns you to the previous screen.
	Right Pressing this button moves the displayed cursor one position to the right.
	Up Pressing this button takes you to the previous screen or menu item.
	Down Pressing this button takes you to the next screen or menu item.
	Select Pressing this button selects or confirms the highlighted value.
	Cancel Pressing this button cancels the current selection and returns you to the previous screen.
	Graphic Pressing this button takes you to a graphical data display.
	Numeric Pressing this button takes you to a numeric data display.
	Info Pressing this button takes you to a detailed information screen.
	Edit Pressing this button allows you to edit the displayed parameter.
	Pressing these buttons allow you to navigate parameter tables in the setup screens.
	Pressing both buttons allows you to perform the described action.

## More screens access

You can access additional screens.

Pressing the navigation button associated with the more icon brings up a list of additional screens related to the displayed screen. Press cancel to remove the list. If you do not press any button, the list automatically disappears after a short period of time.

## Overrange indication

If any value measured by the meter is too large to fit on the meter’s display, the meter initially reduces the size of the text to try and make the value fit.

If the value is still too large to be displayed, the meter truncates the value starting with the least significant digit, and encloses the truncated value in a red box.

## Display menu

The display menu allows you to select data for viewing and to access the setup menu.

**NOTE:** Your meter’s menus may appear slightly different than shown depending on your display settings.

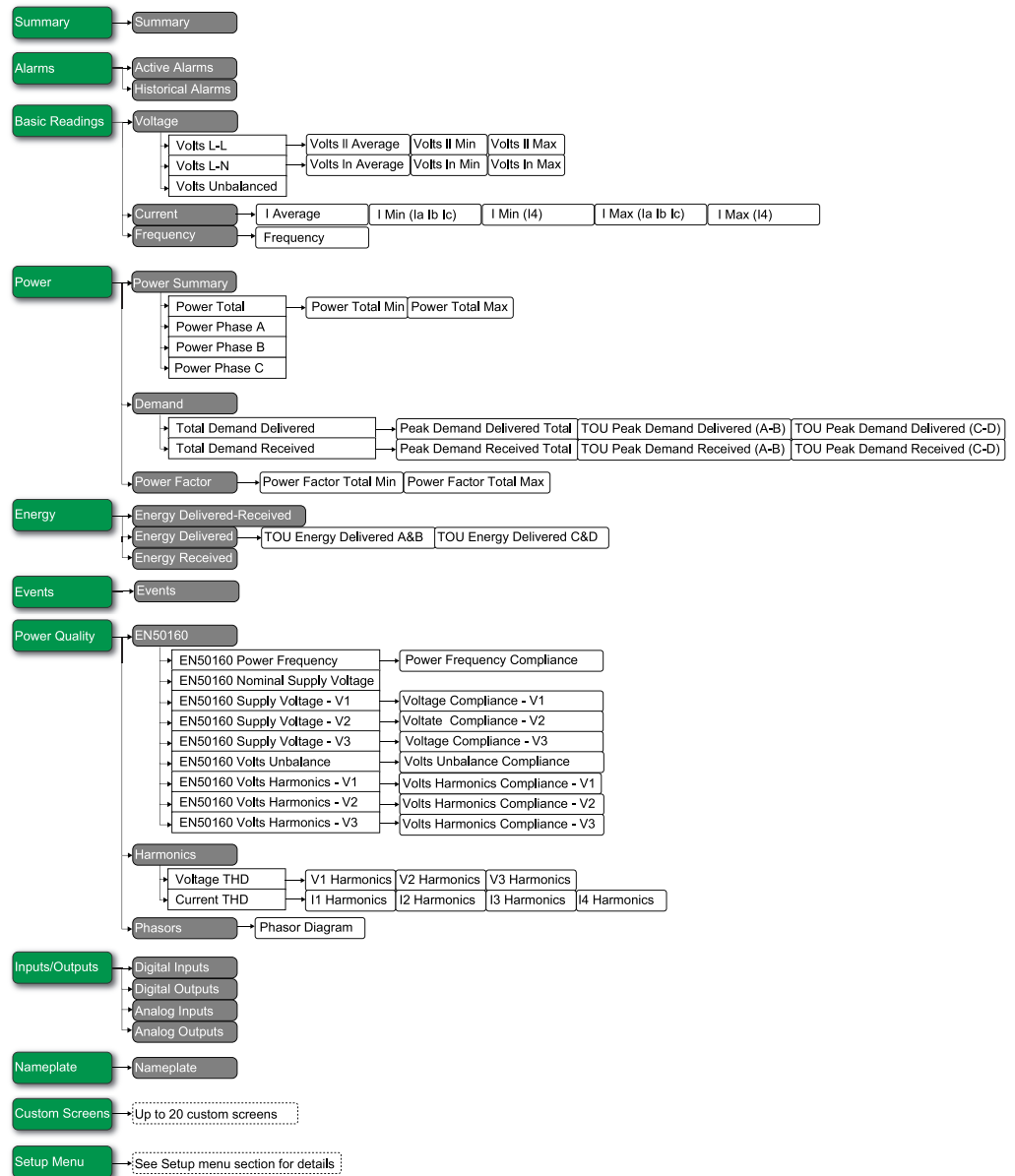

## Data display screens

Your meter’s default display screens show measured and calculated information about the power system being monitored.

Menu	Menu screens	Content
Summary	Summary	Power system summary
Alarms	Active alarms, historical alarms	Active and historical alarms can be viewed and acknowledged.
Basic readings	Voltage, current, frequency	<ul style="list-style-type: none"> <li>Power system voltage (line-to-line or line-to-neutral), current and frequency values.</li> <li>Average, minimum and maximum values are also provided.</li> </ul>
Power	Power summary, demand, power factor	<ul style="list-style-type: none"> <li>Per-phase and total kW, kVAR and kVA values, along with minimum and maximum values.</li> <li>Delivered and received demand values including peak demand.</li> <li>Per-phase and total power factor along with minimum and maximum values.</li> </ul>
Energy	Energy	Energy delivered-received, delivered and received.
Events	Events	Meter event log entries listing and details.
Power quality	EN50160, harmonics, phasors	<ul style="list-style-type: none"> <li>EN50160 values.</li> <li>Voltage and current harmonics, with individual and total harmonic values.</li> <li>Phasor diagram with magnitude and angle values.</li> </ul>
Inputs/outputs	Digital inputs, digital outputs, analog inputs, analog outputs	Digital and analog I/O values and counts.
Nameplate	Nameplate	Meter model, firmware version and serial number, along with owner and tag information.
	Nameplate (MID meter only)	Feature set, firmware version, firmware CRC, Pulse constant and template information
	Nameplate (MID meter only)	Volts mode, nominal voltage, nominal current, nominal frequency, PT ratio and CT ratio
Custom screens	—	Custom screens

## Data viewing using your meter's display

Use the navigation buttons to view data on your meter's display.







The following examples show how to use the navigation buttons to view data in numeric or graphical format, select and view additional menu screens, and view detailed information about alarms and acknowledge them.

**NOTE:** Your display may appear differently than shown, depending on your meter's power system and display settings.

**NOTE:** Your navigation icons change color depending on the type of screen being viewed. If an icon is gray, that navigation option is not available and nothing will happen when you press the button associated with that icon.

### Example: viewing the alarm screens

Use the display navigation buttons to access the alarm screens, display detailed information, and acknowledge active and historic alarms.

1. Press  to display the menu. Press  or  until **Alarms** is highlighted. Press  to display the alarm screens. Press  until **Active Alarms** is highlighted. Press  to display active alarms. The **Active Alarms** title lists, in brackets, the total number of active alarms.

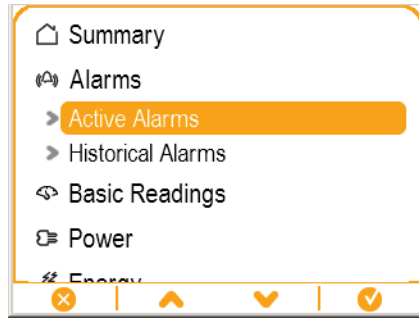

2. Press or to highlight a specific alarm, in this case an unbalanced currents alarm. Press to display detailed information about the highlighted alarm, and press to return to the **Active Alarms** screen. Press both and simultaneously to acknowledge all active alarms.

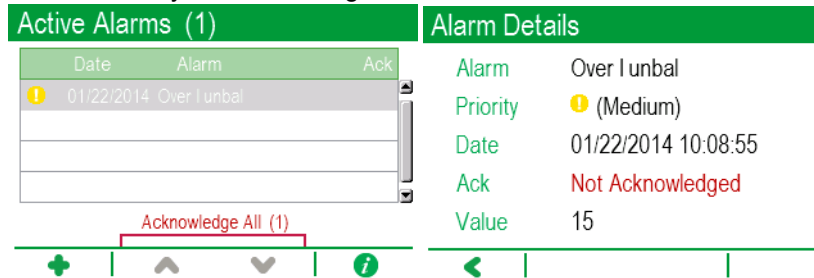

3. Press to display the menu. Press to highlight **Historical Alarms**. Press to display historical alarms. The **Historical Alarms** title lists, in brackets, the total number of historic alarms.
4. Press or to highlight a specific alarm, in this case a 4-30 voltage interruption alarm. Press to display detailed information about the highlighted alarm. Press both and simultaneously to acknowledge all historical alarms.

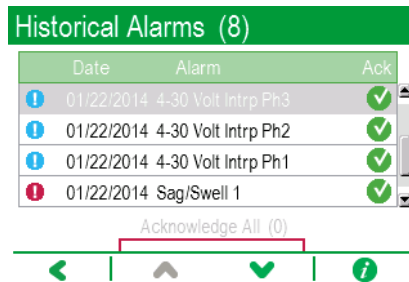

5. Press to return to the menu.

### Example: viewing the voltage screens

Use the display navigation buttons to view screens, display detailed information, and display graphical representations of measured voltage data.

1. Press to display the menu. Press or until **Basic Readings** is highlighted. Press to view the basic readings screens. Press until **Voltage** is highlighted. Press to view the voltage screens. Voltage line-to-line values are displayed.

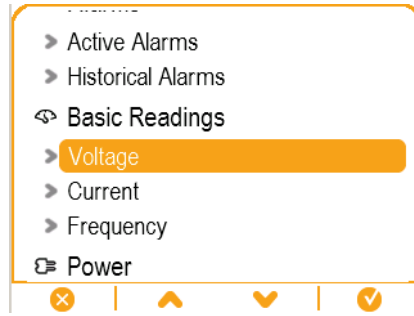

- Press to view a graphical display of historic voltage values, then press **888** to return to the numeric display. Press to show a list of additional screens.

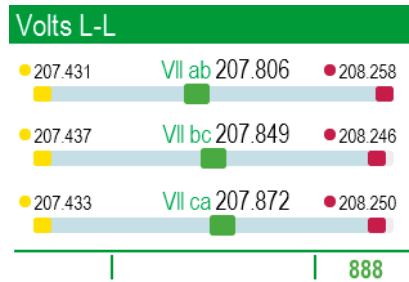
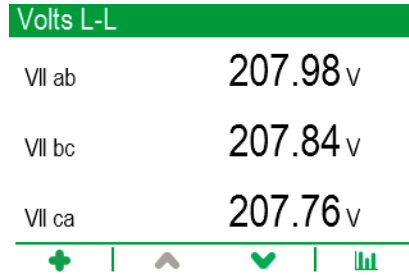

- Press or to highlight an additional screen, in this case, **Volts II Average**. Press to go to the highlighted screen. **Volts II Average** displays the average line-to-line voltage.

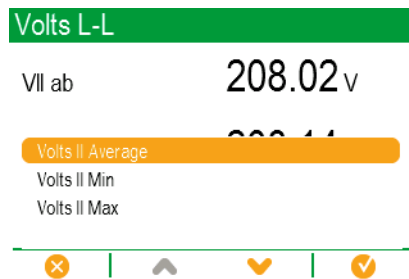

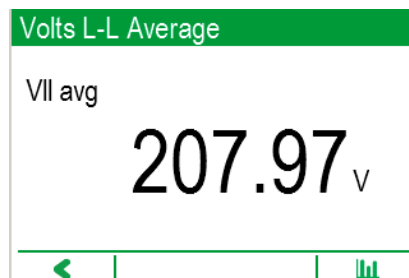

- Press to view a graphical display of average voltage values, then press **888** to return to the numeric display. Press to return to **Volts L-L**.

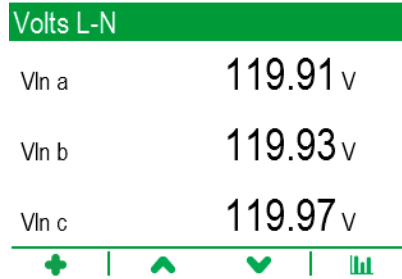

5. Press  to view **Volts L-N**, which also has additional screens and the ability to view the information in a graphical format.



6. Press  again to view **Volts Unbalanced**. This is the last voltage screen, so  is grayed out and unavailable. Press  to return to **Volts L-N**, and press again to return to **Volts L-L**.

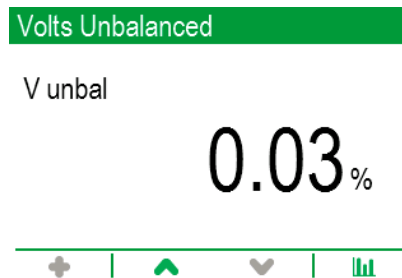

## Setup menu

Meter configuration can be performed through the display, using the meter's webpages or through software.

This section contains information on how to set up the meter using the display. You must have your meter's security settings configured to allow front panel (display) programming in order to set up the meter using the display.

**NOTE:** Your display may appear differently than shown, depending on your meter's power system, configuration and display settings.

**NOTE:** Some setup parameters cannot be configured when revenue security is enabled.

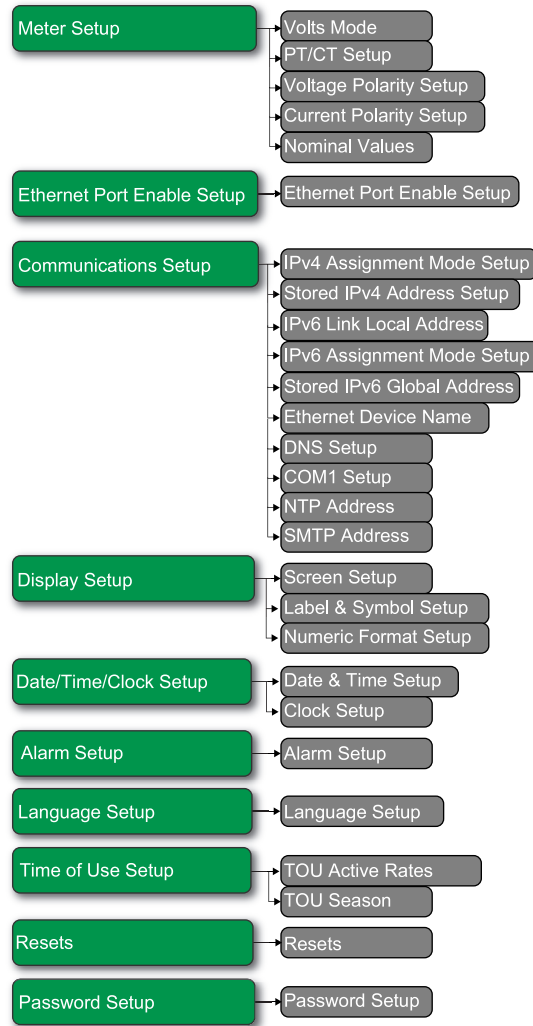

## Meter setup using your meter's display

Use the navigation buttons and displayed parameters to configure your meter.

The following example shows how to use the navigation buttons to select parameters, enter numeric information or select parameter values from lists.

**NOTE:** Your display may appear differently than those shown, depending on your meter's power system and display and localization settings.

**NOTE:** Your navigation icons change color depending on the type of screen being viewed. If an icon is gray, that navigation option is not available and nothing will happen when you press the button associated with that icon.

**NOTE:** Your meter goes back to displaying data after a period of inactivity in the setup menu screens.



**NOTE:** Your meter locks you out of display configuration after you have exceeded the maximum number of attempts to enter a password.

Your meter's default display password is 0 (zero).





### Example: setting volts mode and PT/CT ratios

Use the display navigation buttons to set your meter's volts mode and PT ratios.

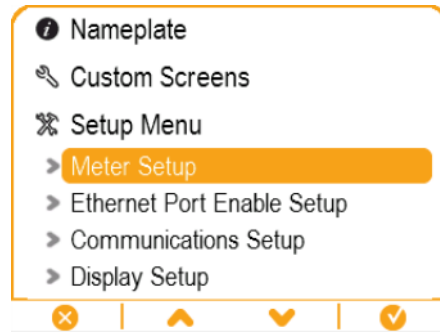

**NOTE:** Potential transformers (PT) are also known as voltage transformers (VT).

1. Press  to display the menu. Press  until **Setup Menu** is highlighted. Press  to display the **Setup Menu**. The **Setup Menu** lists the setup selections on your meter.



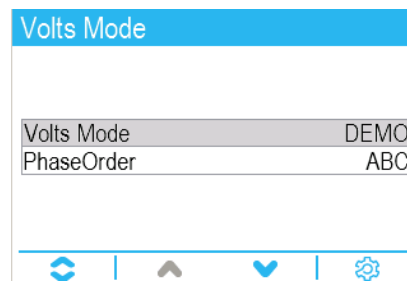

2. Press  or  to highlight the different setup menu selections. Highlight **Meter Setup** and press  to select the meter setup screens. The **Volts Mode** setup screen is displayed.
3. Press  to highlight **Volts Mode**. Press  to edit the volts mode. The **Enter Password** screen is displayed.



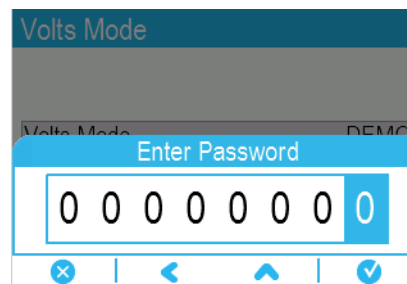

4. Press  to change the value of the highlighted digit (0 - 9). Press  to go to the next digit. Press  to enter your password. The **Volts Mode** configuration screen is displayed.



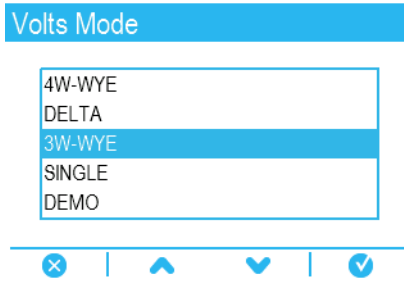



5. Press  or  to highlight the desired volts mode from the list, in this case, 3W-WYE. Press  to select the highlighted volts mode. A confirmation screen is displayed, showing your meter's previous setting and newly selected setting.

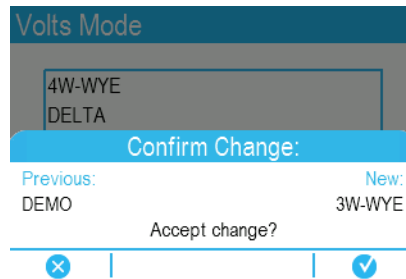







6. Press  to confirm, and the new setting is applied to your meter. Press  to cancel and maintain your meter's original setting.

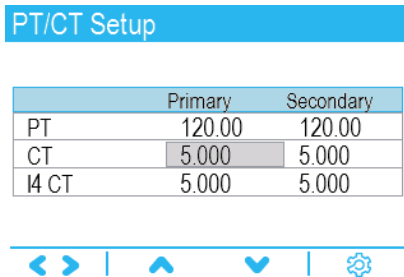

7. In the **Volts Mode** screen, press  to go to the **PT/CT Setup** screen.
8. In the **PT/CT Setup** screen, press   to highlight the potential transformer (PT) or current transformer (CT) value for editing. Press  to edit the highlighted value.

**NOTE:** If you have exceeded the password timeout period, you are prompted to enter your meter's display password.



9. Press  to change the value of the highlighted digit (0 - 9). Press  to go to the next digit. Press  to enter the new value. When the confirmation screen is displayed, press  to confirm the new value or  to revert to the original value.

## Related Topics

- Minimum configuration requirements for basic metering

## Using the onscreen keyboard

Use the onscreen keyboard to provide login credentials on your meter's display.

When advanced security has been enabled on your device through ION Setup, many functions require you to provide your advanced security username and password. Use the onscreen keyboard to provide these credentials.

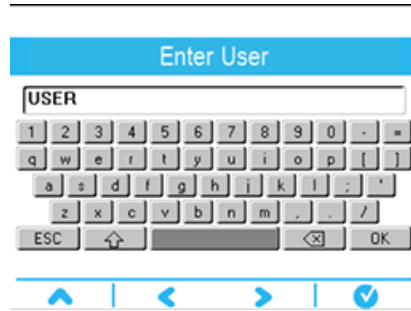

When you access a feature that requires your username and password, the onscreen keyboard appears.



1. Use the left, right and up buttons to move the highlighted key.

Pressing up from the top row returns the highlighted key to the bottom row and pressing left or right at the end of one side causes the highlighted key to wrap around to the opposite side.

2. Press select to input the highlighted key.

- Select  to switch to the uppercase keyboard characters and select  again to switch back.
- Use  to delete the last character entered.

3. Enter your username and select .

The Enter Password field appears.

**NOTE:** When entering your username, the meter ignores any leading zeros. For example, USER1, USER01 and USER001 are all recognized by the meter as USER1.

4. Enter your password and select .

If the username or password is not correct, a security message is displayed. All invalid access attempts are recorded in the event log.

## Display setup

You can configure your meter's basic display parameters using the display.

### Screen setup

Parameter	Values	Description
Backlight Timeout	0 to 720	Specifies how many seconds the display's backlight remains lit after the last button press

### Label & symbol setup

Parameter	Values	Description
Phase Lbls	ABC, 123	Sets the voltage and current phase labels
Measurement Symbols	IEEE, IEC	Specifies whether IEEE or IEC measurement symbols are applied to displayed values
PF Convention	IEEE, IEC	Specifies whether IEEE or IEC power factor conventions are applied to displayed values

### Numeric format setup

Parameter	Values	Description
Digit Grouping	1000.0, 1,000.0, 1 000,0	Specifies how digits are grouped for display
Volts Resolution	1., 1.X, 1.XX, 1.XXX, 1.XXXX	Specifies the number of decimal places displayed for voltages
Current Resolution	1., 1.X, 1.XX, 1.XXX, 1.XXXX	Specifies the number of decimal places displayed for currents
Power Resolution	1., 1.X, 1.XX, 1.XXX, 1.XXXX	Specifies the number of decimal places displayed for power and energy measurements

### Language setup

Select the language to be shown on the meter's display.

By default, your meter has the following languages:

- English
- Spanish
- French
- German
- Italian
- Portuguese
- Russian
- Chinese (simplified)

### Remote display troubleshooting icons

Your meter's remote display shows troubleshooting icons in addition to the meter's status LED information.

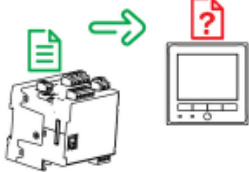
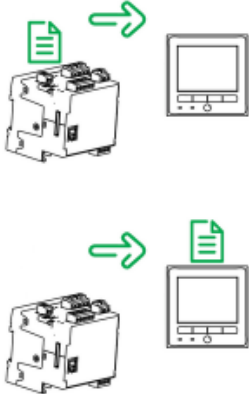
Icon	Description
	<p>Your remote display cannot communicate to your meter. Check the connection between your meter and the display. Check the meter's status LED to confirm that the meter is operating normally.</p>
	<p>Your remote display needs updated firmware for compatibility with your meter.</p>
	<p>Your remote display is undergoing a firmware upgrade. Do not disconnect your remote display from your meter.</p>

## Creating custom displays using ION Setup

You can use ION Setup to program new custom displays.

1. Start ION Setup.
2. Open the Setup Assistant for your meter.
3. Navigate to **Custom Displays**.
4. Select **Custom Displays** from the **Front Panel** tab and click **Edit**. ION Setup loads your meter's display information into the **Display Editor** screen.
5. Rename, delete, or change the order of custom displays through the **Display Editor** screen. Click **New** to add a new display. Click **Edit** to bring up the **Display setup** screen, where you can configure new or existing custom displays.
6. Configure your screen.
  - **Screen Type**: Specify the number of parameters displayed on the screen.
  - **Screen Title**: Enter the title to be shown at the top of your custom display.
7. Click **Edit** to select the displayed parameters. The number of parameters displayed is determined in the **Screen Type** selection described above.

8. Select your digit display properties.
  - **Resolution:** Specifies the number of decimal places displayed.
  - **Last Digit:** Enter the title to be shown at the top of your custom display.
9. Click **Send** to save the changes in the meter.

# Security

## Security overview

Your Siemens Industry product is equipped with security-enabling features.

These features arrive in a default state and can be configured for your installation needs. Please note that disabling or modifying settings within the scope of these individual features can impact the overall security robustness of the device and ultimately the security posture of your network in either positive or negative ways. Review the security intent and recommendations for the optimal use of your device's security features.

Products are hardened to increase security robustness. This is an ongoing process consisting of secure development practices, inclusion of security features and testing at our security test facilities. Following system hardening best practices is also necessary to help ensure your overall system security.

## Security features on your device

Your device comes with security features that you can configure to help protect against unauthorized configuration and access to your device's data through its user interfaces or communications.

### Network port control

This feature provides you with the ability to enable and disable individual network ports and to change port numbers from their default values.

Leaving unused ports open provides additional attack surfaces for a potential attacker. Minimizing the number of ports open on the device reduces the likelihood of unauthorized intrusions by providing fewer entry points.

Once your meter is configured, all network ports related to unused protocols should be placed in the OFF state/position. Minimize the number of open ports, temporarily opening ports for activities such as periodic firmware / software downloads when required.

Network ports that remain open should be changed from their default values wherever possible.

#### Related Topics

- Network protocol control
- Ethernet configuration

### Enable/disable communication ports

You can disable physical communication ports when they are not in use.

These can be disabled through the display, ION Setup or through the meter's webpages.

Leaving unused ports open provides additional attack surfaces for a potential attacker. Minimizing the number of ports open on the device reduces the likelihood of unauthorized intrusions by providing fewer entry points.

### Related Topics

- Disable the COM port using the meter webpages
- Disabling the COM port using the meter display
- Disabling the COM port using ION Setup

## Revenue and billing security features

Selected meter models support additional hardware and firmware locking to prevent unauthorized access to revenue-related parameters and settings.

### Related Topics

- Revenue metering

## Event logging

Your meter records meter functions, events and changes to meter parameters and logs them as entries in the event log.

Event logs entries are timestamped and user-related events are associated with the username that was logged into the meter. Security-related events such as resets, successful or unsuccessful login attempts, user lockout or meter configuration changes are also recorded in the event log along with a timestamp and the username associated with the event. The event log can be used to monitor system events, assist in confirming security compliance, or assist in tracking unauthorized intrusion attempts.

### Related Topics

- Event log overview
- User triggered event log entries

## Syslog

This feature allows you to push event log information to a centralized syslog server.

When the event log of a meter is full, new log entries can overwrite existing entries. By pushing the event log information to a syslog server, older event log information can be preserved and used as part of an information storage and retrieval strategy.

## Advanced security through the meter's display

Advanced security is available through the meter's display.

When advanced security is enabled on your meter, user privileges created through ION Setup are enforced through the meter's display. When advanced security is enabled, changes to meter configuration are associated with the username that is logged into the meter. The advanced security password used to access the meter uses an expanded character set, allowing for a more robust password.

## NERC CIP

North American Electric Reliability Corporation (NERC) Critical Infrastructure Protection (CIP) is a set of standards and requirements designed to help protect the North American power generation and transmission system and covers aspects such as critical cyber asset identification, electronic security perimeters, and systems security management.

This meter has incorporated security features that allow it to be part of NERC CIP compliant facility. For example, the security features of this meter include user accounts with configurable passwords and permissions; network port control configuration; security access and event log replication to an external server; and digitally signed firmware.

For more information about NERC or the CIP standards, go to the North American Electric Reliability Corporation's website at <http://www.nerc.com>.

## Security recommendations and best practices

### Recommended security configuration

Recommended security configuration settings help improve security on your meter.

- Ensure that your meter requires a password for configuration through the display or communications.
- Configure the protocol lockouts to help minimize access to your meter.
- Enable advanced security on your meter.
  - Configure users and passwords to help minimize access to your meter.
- Disable communications for all unused network ports and protocols.
- Change the connection ports from their default values wherever possible.
- Save a copy of your meter's ION Setup security configuration (\*.scf) file in a secure location for future reference or troubleshooting. Your meter's security configuration file can be loaded onto other meters of the same type to configure their security settings.
- For the highest level of security, use a revenue-locked meter with advanced security enabled and configured for minimum access.
- Set your meter's time synchronization source to a secure communications port, and disable time synchronization on all other ports.

### Password best practices

Recommended password best practices help to improve security on your meter.

- Change your meter's password from the default value.
- Make your meter's display and user-specific passwords as complex as possible.
  - NOTE:** Make sure that the user password you enter is compatible with the software used to communicate with your device.
- Schedule regular changes to your meter's display and user passwords.
- Record your meter's display and user passwords in a secure location.

Your meter's username and password cannot be retrieved if lost. If you lose your meter's user access information, you will not be able to change any settings or access any data that requires this login information.

### **NOTICE**

#### **LOSS OF ACCESS**

**Failure to follow these instructions can result in loss of access to the device.**

Record your device's user and password information in a secure location.

## Standard and advanced security features

Security settings allow you to configure security features on your meter.

Parameter	Standard/ advanced	Details
Meter password	Standard/ advanced	The meter's password is used to confirm user access when configuring the meter through the display or over communications. The default meter password is 0 (zero).
Active web server	Standard/ advanced	This option allows you to enable or disable your meter's webpages.
Allow web server programming	Standard/ advanced	This option allows you to enable or disable the ability to configure your meter using the meter's webpages. <b>NOTE:</b> To enable <b>Allow web server programming</b> , you must have active web server enabled.
Allow Modbus programming	Advanced only	This option can only be enabled in advanced security and is disabled for standard security.
Allow front panel programming	Standard/ advanced	This option allows you to enable or disable the ability to configure your device using the display.
Allow broadcasting time synchronization	Advanced only	This option can only be disabled in advanced security and is enabled for standard security.
Protocol lockout	Standard/ advanced	This option allows you to configure the number of access attempts before lockout, lockout duration and meter access event priorities.

### Advanced security user configuration

Advanced security allows you to configure users with specific access levels and passwords.

## Security configuration process

The security configuration process has four basic steps: review security recommendations, set basic security options, configure communications protocol lockout settings, and configure users.

1. Review security recommendations
2. Set basic security options
  - Change the display (front panel) password.
  - Disable broadcasting time synchronization (advanced security only).
  - Enable/disable display (front panel) and Webserver programming.
  - Enable/disable Modbus programming (advanced security only).
3. Configure communications protocol lockout options
  - a. Configure protocol-specific settings:
    - Set the number of attempts before the protocol is locked out.
    - Set the session timeout.
  - b. Configure global lockout settings:
    - Enter a lockout duration.
    - Set the priority of meter access events.
4. Configure users (advanced security only)
  - Determine user access.

- Set user passwords.

## Communications protocol lockout overview

The communications protocol lockout security feature allows you to set the number of invalid login attempts that each user can make using a particular protocol and communications method before being locked out (a user is defined as a user login and password combination).

For protocols that are not session-based (ION), you can configure how often the device registers invalid login attempts by configuring the session timeout. You can also configure the lockout duration for all configurable protocols.

Session timeout specifies the active duration for a protocol; during this time, repeated invalid login attempts using the same USER/password combination are not registered (repeated invalid attempts with different combinations are still registered). Session timeout only applies to protocols which are not session-based (ION) and send credentials with each packet, and should be configured to help prevent accidental lockouts and filling the meter's event log with protocol access events

**NOTE:** If protocol lockout is set to 0 (zero) there is no limit to the number of invalid login attempts and the protocol will never be locked out. However, the invalid login attempt events are recorded if the meter access events are configured to record invalid access attempts.

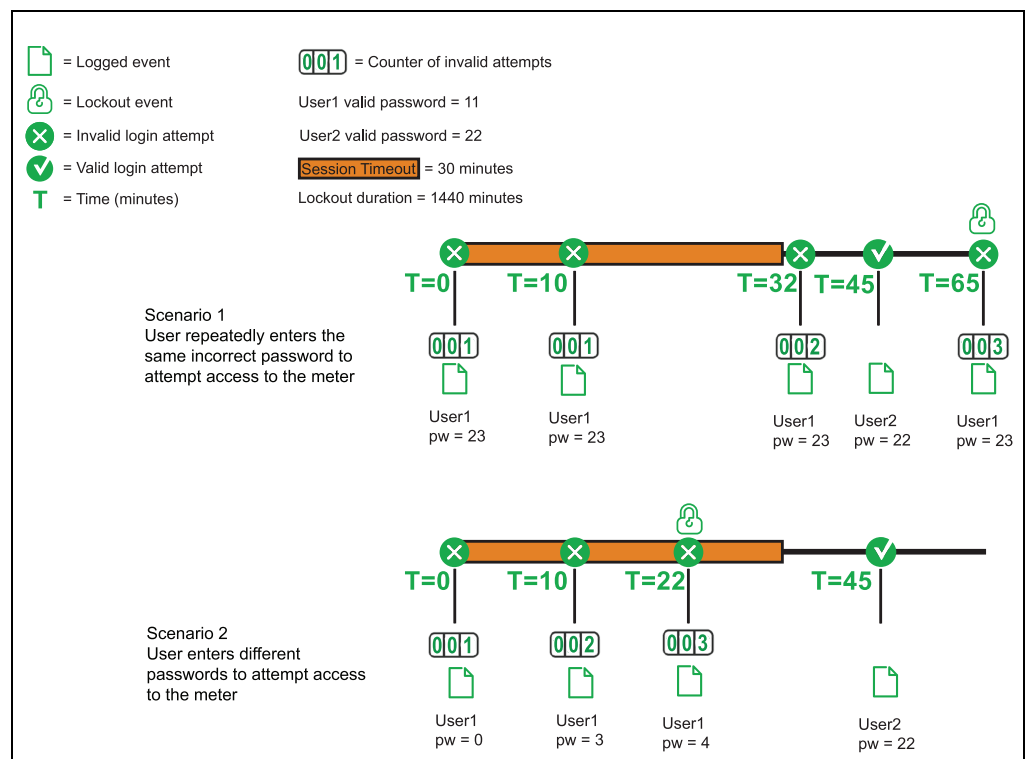

Once a user is locked out, the device will not accept login attempts from that user on that protocol and communications method until the lockout duration has passed. Invalid login attempts accumulate until the user has completed a valid login or is locked out. If the user enters the correct USER/password combination before being locked out, the invalid attempt counter is reset to zero. Even if the user is locked out using ION over Ethernet, that user can still access the device by entering the correct USER/password combination over a different protocol and communications method (for example, connecting to the device's RS-485 serial port using Modbus protocol).

## Related Topics

- Configuring standard security using ION Setup

## Password setup

It is strongly recommended that you change your meter's password from the default value of 0 (zero).

Your meter's username and password cannot be retrieved if lost. If you lose your meter's user access information, you will not be able to change any settings or access any data that requires this login information.

### **NOTICE**

#### **LOSS OF ACCESS**

**Failure to follow these instructions can result in loss of access to the device.**

Record your device's user and password information in a secure location.

Screen title	Parameter	Values	Description
Password Setup	Password	0 to 99999999	Sets the password that must be entered in order to configure parameters using the meter's display  <b>NOTE:</b> This is also the password used to access the meter's webpages when standard security is enabled

## Related Topics

- Using the onscreen keyboard

## Advanced security username and password through the display

You can enter your username and password on the meter's display when advanced security is enabled.

When you attempt to change a setting through the display of a device that has advanced security enabled, you are prompted to provide the username and password created using ION Setup. If the access level associated with the user is not sufficient to change the setting, you cannot modify the setting and the message `INVALID SECURITY LEVEL` is displayed.

**NOTE:** Only standard printable ASCII characters are allowed for passwords created in ION Setup.

## Changing your meter's display password using the display

You can change your display password using your meter's display.

**NOTE:** The display password is also used as the webpage password if standard security is enabled.

1. Go to **Setup Menu > Password Setup**.
2. Configure your meter's display password.

## Configuring standard security using ION Setup

You can fully configure standard and advanced security on your meter using ION Setup.

In order to change security settings, you must be logged into ION Setup with an appropriate ION Setup user level. You must also have the appropriate meter-level security access to configure meter security.

1. Start ION Setup.
2. Open the Setup Assistant for your meter.
3. Navigate to **Security**. Select Security Mode and click **Edit**. The open dialog box appears.
4. Select the appropriate security configuration file (\*.scf) to configure your meter:
  - Standard: allows you to configure basic security and communications protocol lockout.
  - Advanced: includes the standard security features and adds user access/password security settings.
5. The standard options or advanced options configuration screen appears. Configure the security parameters as required, some parameters can only be configured using advanced security.  
  
Click **Next** to configure protocol access information. The protocol lockout screen is displayed.
6. In the protocol lockout screen select the protocols that you want to be protected by the protocol lockout function. Select each protocol and click **Edit** to configure the protocol-specific parameters.
7. Enter the lockout duration (in minutes).
8. Click **Events** to configure user access event priorities. The Event Priorities screen appears.
9. Configure the user access event priorities.

- If you have selected standard security, click **Finish**. You are prompted to save your security configuration to a file which can be loaded onto other meters.

**NOTE:** If you chose to save your security file, enter a descriptive name and click **Save**. It is recommended that you do not overwrite the default security files.

If you have selected advanced security, click **Next** to configure user access and passwords.

### Security parameters available using ION Setup

Parameter	Standard/advanced	Details
Meter password	Standard/advanced	Default meter password is 0 (zero).
Active web server	Standard/advanced	This option allows you to enable or disable your meter's webpages.
Allow web server programming	Standard/advanced	This option allows you to enable or disable the ability to configure your meter using the meter's webpages. <b>NOTE:</b> To enable allow web server programming, you must have active web server enabled.
Allow Modbus programming	Advanced only	This option can only be enabled in advanced security and is disabled for standard security.
Allow front panel programming	Standard/advanced	This option allows you to enable or disable the ability to configure your device using the display.
Allow broadcasting time synchronization	Advanced only	This option can only be disabled in advanced security and is enabled for standard security.

### Protocol-specific security parameters available using ION Setup

Parameter	Values	Description
Protocol lockout	0 - 255	The number of invalid login attempts before access is denied. If protocol lockout = 0, there is no limit to the number of invalid login attempts and the protocol will never be locked out.
Session timeout	1 - 43200 minutes (30 days)	The interval between access checks for non-session based protocols.

### Related Topics

- Recommended security configuration
- Protocols, ports and connections

## Configuring users and passwords using ION Setup (advanced security only)

Use ION Setup to configure users and passwords.

In order to change security settings, you must be logged into ION Setup with an appropriate ION Setup user level. You must also have the appropriate meter-level security access to configure meter security.

You must have configured the standard security settings on your meter using ION Setup.

This task assumes that you are in the user configuration screen in the security wizard in ION Setup.

- In the user/passwords screen, select (check) the user that you want to configure to view the user access options.

2. Select the appropriate values to configure the user's access.

Some access levels require that multiple access options be selected. For example, if you enable Security Config Access, Full Meter Config Access is also enabled.

3. Select the user and click **Password**. The password entry screen appears.

The password entry screen appears.

4. Enter the desired password and click **OK**.

5. Continue configuring user access and passwords for each unique user of the meter.

**NOTE:** Select **Show password** when a user selected to display the password associated with that user. This feature is intended to help ensure that the correct password is entered for each user.

6. Click **Finish** to save your security configuration to the meter. You are prompted to save your security configuration to a file which can be loaded onto other meters.

**NOTE:** If you chose to save your security file, enter a descriptive name and click **Save**. It is recommended that you do not overwrite the default security files.

### Advanced security access levels

Access	Description
Time sync	The user can set the meter's time and time synchronization parameters.
Read	The user can view all parameters except the security configuration.
Peak demand reset	The user can reset peak demand values.
Comm config	The user can configure the communication settings.
Test mode	The user can put the meter into test mode (not applicable to all devices).
Full meter config	The user can configure all aspects of the meter except demand resets, test mode or security.
Security config	The user can configure security.

## Loading an existing security configuration file (.scf) using ION Setup

You can load an existing security configuration file (\*.scf) onto your meter using ION Setup.

The \*.scf file can be a configuration for either standard or advanced security and must be from the same model of meter.

In order to change security settings, you must be logged into ION Setup with an appropriate ION Setup user level. You must also have the appropriate meter-level security access to configure meter security.

1. Start ION Setup.
2. Open the Setup Assistant for your meter.
3. Navigate to **Security**. Select **Security Mode** and click **Send**. The **Open** dialog box appears.
4. Navigate to the location of the \*.scf file you want to load onto your meter. Select the \*.scf file and click **Open**. The \*.scf file is loaded onto your meter.

# Communications

## Communications overview

Your meter supports several different protocols over its Ethernet and serial connections.

Your meter's default protocol implementation meets the needs of most systems with only basic configuration. You can customize these implementations to meet your specific needs. These are advanced procedures that require an understanding of your meter's architecture, the supported protocols, and the communications network and power system that your meter is connected to.

## Ethernet communications

The meter supports a single IP address on both of its two physical Ethernet connections.

Your Ethernet connection source should be installed in a location that helps minimize the overall Ethernet cable routing length and complexity of your network.

Your device's second Ethernet port acts as an Ethernet switch to help simplify network connections and reduce installation time and costs, by having shorter Ethernet cable runs between devices without needing additional Ethernet routers or repeaters. You cannot connect your meter to two different Ethernet networks. The two Ethernet ports do not split the signal, so connecting both of the ports should not impact your communications speed.

The meter uses dual-stack IPv4/IPv6 routing technology to manage network communications and allow network hosts to communicate with the meter using either IPv4 or IPv6.

## Protocols, ports and connections

The Ethernet protocols supported by your device allow simultaneous connections through the IP service ports.

**NOTE:** Not all port numbers are configurable for all protocols.

Protocol	Port (default)	Number of connections
ION	7700	8 <sup>1</sup>
DNP	20000	
Modbus TCP <sup>3</sup>	502	
Modbus RTU over Ethernet <sup>3</sup>	7701	
Modbus TCP (dedicated) <sup>3</sup>	502	32
EtherGate <sup>4</sup>	7801	1
DHCP	67 (68)	1
FTP	21 (20)	2
Webserver (HTTP) <sup>2</sup>	80	10
SNMP	161	N/A
SMTP server (email) outgoing only	25	1
NTP	123	1

Protocol	Port (default)	Number of connections
IEC 61850	102	4

<sup>1</sup>These 8 simultaneous connections can be used by ION, Modbus TCP, Modbus RTU over Ethernet, or DNP. You can have a maximum of 3 DNP connections.

<sup>2</sup>This is used for the meter's webpages.

<sup>3</sup> These protocols must be enabled to allow Modbus Master and Modbus gateway functionality.

<sup>4</sup> This protocol must be enabled to allow EtherGate functionality.

By enabling or disabling TCP/IP protocols, you can control whether or not your meter accepts new socket connection requests from the TCP/IP protocols supported by the meter. Changing settings does not impact existing connections. Depending on the protocol, you can also change the port number.

## Related Topics

- Ethernet configuration

## Self-discovery over Ethernet

Your meter supports DPWS (devices profile for web services) which allows for self-discovery of the meter when it is connected to your local area network.

When you connect your meter to your network, your meter automatically appears in your network in Windows Explorer under Other Devices. By default, the meter is named <meter type>\_<last six digits of MAC address>. For example, a meter with a MAC address of 0060784173393 appears on the network as <meter type>\_173393.

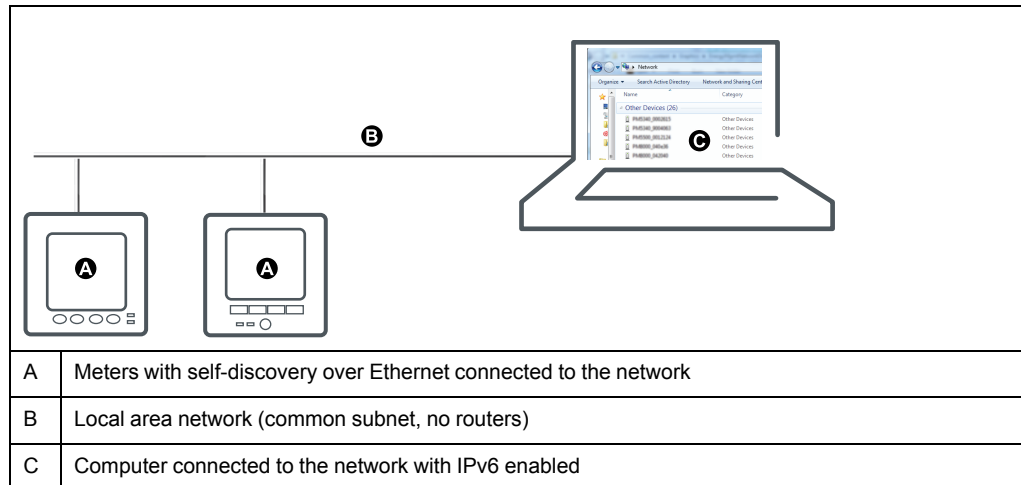

### Considerations for using self-discovery over Ethernet

- For self-discovery, the meter must be connected directly to the network using only a cable or switches, and not going through a router.
- You must use a computer running Windows 7 or later with IPv6 enabled in order to use self-discovery over Ethernet.
- The computer and the meter must be on the same subnet.
- You do not need to configure your meter's IP address for self-discovery over Ethernet; an IPv6 address is automatically generated from your meter's MAC address and self-discovery takes place over IPv6.

### Accessing the meter through self-discovery

You can use Microsoft® Windows Explorer to locate and access the meter on your local network.

**NOTE:** Some networks restrict device self-discovery over a wireless connection. If this is the case, make sure your computer is connected to the network using an Ethernet cable.

1. Connect the meter's Ethernet port to the local area network (LAN).
2. Start Windows Explorer.
3. Click Network.  
The connected network devices display.
4. Locate your meter with the name <Device Name>\_<Last 6 digits of MAC address>.
5. Double-click the icon to open the meter webpages.

## Ethernet configuration

In order to use Ethernet communications, you must configure your device's IP settings.

You need to enter network information for any Ethernet servers used by the device (for example, a DNS or email server). Contact your network system administrator for your IP address and other Ethernet network configuration values.

**NOTE:** For meters that do not have a display, you must connect your meter directly to your computer to set a unique IP address for each device or configure the meter to use a DHCP server to acquire IP addresses.

It is recommended that you test your communications with the meter after changing any communications-related settings (for example, communicating with the meter using the fully-qualified domain name if using DNS or with assigned addresses after these are provided by the DHCP server). In addition, make sure that any software or other devices communicating with the meter are using the new settings.

### Initial Ethernet configuration versus changing existing Ethernet settings

There are two scenarios when configuring your meter's Ethernet communications settings: initial configuration and changing the existing addresses when the meter is in use.

- Initial configuration: Configure your device's Ethernet settings manually using the display or by connecting your meter directly to your computer and using a web browser to access the device's webpages. Alternately, you can connect your meter to the network and configure it to use a DHCP server to acquire an IP address.

**NOTE:** It is recommended during initial configuration that you use a connection method other than the one you are trying to configure. For example, if you are configuring DHCP IPv4 settings, connect to the meter using the IPv6 LinkLocal address or a serial connection. This allows you to configure the meter without being disconnected.

- Changing existing IP settings: After the meter's Ethernet port is configured and connected to the LAN, you can use ION Setup to configure meter settings, in addition to using the display or meter webpages.

In either case, modify your meter's Ethernet settings to those provided by your network system administrator before connecting the device to your local area network (LAN).

### IP address format and ranges

When you set your meter's IPv4 or IPv6 addresses, make sure you use the correct format and valid ranges.

Protocol	Format
IPv4	0.0.0.0 to 255.255.255.255
IPv6	:: to FFFF:FFFF:FFFF:FFFF:FFFF:FFFF:FFFF:FFFF:FFFF:FFFF The double colon indicates that gaps are filled with zeroes to make the IPv6 address the correct length (32 hexadecimal numbers)

All meters ship from the factory with the IPv6 global address and IPv6 gateway undefined (set to “:”). To communicate with the meter using IPv6 outside the local network, you must configure these settings manually or use DHCP to assign the addresses to the meter. Within the local network, you can use the meter’s IPv6 Link Local address.

### IP addresses and network port numbers

To specify a port for an outgoing IP address, append a colon (:) then the port number to the end of the IP address. For IPv6 addresses, make sure the address is enclosed in square brackets then append the port number. For example, to specify the default port for ftp (port 21), the format of the address is as follows:

- IPv4: 169.254.0.10:21
- IPv6: [FE80::260:78FF:FE04:5943]:21

### Configurable Ethernet settings

‘W’ indicates the setting can be configured (written) while ‘R’ indicates it is read-only.

**NOTE:** Some additional Ethernet settings are available in the Advanced Ethernet menu in ION Setup and on the meter webpages.

Setting	Display	ION Setup	Webpages
IPv4 address	W	W	W
IPv4 Subnet mask	W	W	W
IPv4 Default gateway	W	W	W
IPv4 Assignment Mode (DHCP/Stored)	W	W	W
IPv6 Assignment Mode (DHCP/Stored)	W	W	W
Ethernet Device name	R	W	W
Domain name	R	W	W
IPv6 enabled	—	W	W
IPv6 Link Local Address	R	R	R
IPv6 global address	R	W	W
IPv6 gateway	R	W	W
Ethernet Rx timeout	—	W	W
Modbus TCP timeout	—	W	W
Modbus gateway	—	W	—
MAC address	R	R	R
Ethernet primary DNS	R	W	W
Ethernet secondary DNS	R	W	W

### Configuring Ethernet communications settings using the display

You can configure basic Ethernet communications settings using the display.

Obtain your meter’s IP address and other network information from your network administrator or IT department before you begin.

You can use the display to select the IP address assignment mode for IPv4 and IPv6, configure stored IPv4 addresses, and view other settings. To configure the Ethernet settings that are not available on the display or are read-only, use the meter’s webpages or ION Setup.

1. Go to **Setup Menu > Communications Setup**.
2. Scroll through the screens until you reach the setting you want to configure then press the edit icon.
3. Select the IPv4 or IPv6 **Assignment Mode**, if required.

Option	Description
Stored	The meter uses the IP addresses that you manually enter for IPv4 (address, subnet mask and gateway) and IPv6 (Global address, gateway address).
DHCP / DHCPv6	The meter acquires its IP addresses from your network’s DHCP server.

You can have different assignment modes for IPv4 and for IPv6.

If you set the **IPv4 Assignment Mode** to **Stored**, continue with the remaining steps to configure stored IPv4 addresses. If you are using addresses acquired from a DHCP server, press the down arrow to view the assigned addresses.

4. Go to the **Stored IPv4 Address Setup** screen and press the edit icon.
5. Configure your meter’s stored IPv4 Addresses, as required.

#### Stored IPv4 address settings available using the display

Parameter	Values	Description
IP Address	Contact your local network administrator for parameter values.	Sets the IP address for the meter Your meter’s default IP address is 169.254.0.10
Subnet Mask	Contact your local network administrator for parameter values.	Used if subnetting applies to your network Your meter’s default subnet address is 250.240.0.0
Gateway	Contact your local network administrator for parameter values.	Used in networks with multiple segments Your meter’s default gateway address is 0.0.0.0
MAC Address	Read-only	Your meter’s media access control (MAC) address

### Configuring basic Ethernet settings using the meter webpages

You can use the meter webpages to configure the IPv4, IPv6 and TCP/IP settings for the meter.

When configuring communications parameters, ensure you maintain at least one communication path that allows full access to your device; otherwise you may permanently lose the ability to change your device’s configuration and access to additional data.

## **NOTICE**

### **LOSS OF ACCESS**

**Failure to follow these instructions can result in loss of access to the device.**

Ensure you maintain sufficient access to communicate with and configure your device.

Contact your network system administrator for your IP addresses and other Ethernet network configuration values.

1. Connect to your meter's webpages.

Until you configure other Ethernet connection settings, you can connect to the meter using its default IPv4 address or its IPv6 link local address, or by using self-discovery over Ethernet then double-clicking the meter's network icon.

2. Navigate to **Setup > Ethernet**.
3. Enter the appropriate value for the settings.
4. Click **Advanced Settings** to configure additional Advanced Ethernet settings, such as timeouts and enabling/disabling certain protocols over Ethernet, if needed.
5. Click **Apply**.

**NOTE:** If you are changing the address you used to access the webpages, you will need to reconnect to the webpages after you click **Apply**.

### **Ethernet settings available using the webpages**

<b>Parameter</b>	<b>Value</b>	<b>Description</b>
MAC address	Read-only	The media access control (MAC) address is factory set and is for reference only.
Ethernet device name	configurable	The Ethernet device name is used by DPWS for self-discovery over Ethernet and as the hostname to uniquely identify your meter for DHCP and DNS.  By default, this is set to the meter model plus the last six-digits of the MAC address.
Domain name	Contact your local network administrator for parameter values.	The Ethernet domain name for the network that the meter resides on.
Primary DNS	Contact your local network administrator for parameter values.	The IP address of your network's primary DNS server, if your network uses DNS.
Secondary DNS	Contact your local network administrator for parameter values.	The IP address of your network's secondary DNS server, if your network uses DNS.

### IPv4 settings available using the webpages

Parameter	Value	Description
IPv4 Assignment mode	Stored DHCP	Stored: The meter uses the IP addresses that you manually enter for IPv4 (address, subnet mask and gateway). DHCP: The meter acquires its IP addresses from your network's DHCP server.
Stored IPv4 address	Contact your local network administrator for parameter values.	The Internet protocol address of your device.
Stored IPv4 Subnet Mask	Contact your local network administrator for parameter values.	The Ethernet IP subnetwork address of your network.
Stored IPv4 Gateway	Contact your local network administrator for parameter values.	The Ethernet IP gateway address of your network.
The webpage also displays the acquired IPv4 settings if the Assignment mode is set to DHCP. <b>NOTE:</b> To disable communications using IPv4, set the Assignment mode to Stored and the IPv4 Address to 0.0.0.0.		

### IPv6 settings available using the webpages

Parameter	Value	Description
IPv6 Assignment Mode	Stored DHCPv6	Stored: The meter uses the IP addresses that you manually enter for IPv6 (Global address, gateway address). DHCPv6: The meter acquires its IP addresses from your network's DHCP server.
IPv6 Link Local Address	Read-only	The IPv6 Link Local address is factory set and is read-only.
Stored IPv6 Global Address	Contact your local network administrator for parameter values.	The Internet protocol address of your device.
Stored IPv6 Gateway	Contact your local network administrator for parameter values.	The address the meter uses to route communications to a different network or subnet. If you do not set this or the address is incorrect, you may see slow communications or communications errors.
The webpage also displays the acquired IPv6 settings if the Assignment mode is set to DHCP. <b>NOTE:</b> To disable communications over IPv6, set <b>Enable IPv6</b> in <b>Advanced Settings</b> to "No". <b>NOTE:</b> You must enclose an IPv6 address in square brackets when typing it in a web browser, for example: "http://[fe80::260:78ff:fe04:5943]".		

### Configuring IPv4 / IPv6 communications settings using ION Setup

You can configure your device's IPv4 and IPv6 address settings, such as stored addresses or address assignment mode, using ION Setup.

When configuring communications parameters, ensure you maintain at least one communication path that allows full access to your device; otherwise you may permanently lose the ability to change your device's configuration and access additional data.

## NOTICE

### LOSS OF ACCESS

**Failure to follow these instructions can result in loss of access to the device.**

Ensure you maintain sufficient access to communicate with and configure your device.

Contact your network system administrator for your IP addresses and other Ethernet network configuration values.

1. Start ION Setup.
2. Open the **Setup Assistant** for your device.
3. Select **Communications > Basic Ethernet** and click the **IPv4** or **IPv6** tab.
4. Select the IP address then click **Edit**.

For IPv6, select the **IPv6 Enabled** checkbox to enable IPv6 communications or clear it to disable IPv6 communications.

**NOTE:** The IPv6 Link Local address itself is factory set and is read-only.

5. Select your IP address assignment mode.

Selection	Mode	Description
Use DHCP to obtain an IPv4 address	DHCP	The meter acquires its IP addresses from your network's DHCP server.
Use the following IP address	Stored	The meter uses the IP addresses that you manually enter for IPv4 (address, subnet mask and gateway) or IPv6 (global address and default gateway).

You can have different assignment modes for IPv4 and for IPv6.

6. Configure the settings for the selected mode then click **OK**.  
The changes are saved to the meter. If ION Setup detects that the connection information is already in use, you are prompted to confirm the change.
7. Click **Yes** to confirm the change or **No** to cancel.

An example of an instance where you might want to confirm the change is if you are programming the meter to replace another meter already in service.

### DHCP settings available using ION Setup

Parameter	Value	Description
Device name	Contact your local network administrator for parameter values.	The Ethernet device name is used by DPWS for self-discovery over Ethernet and as the hostname to uniquely identify your meter for DHCP and DNS. By default, this is set to the meter model plus the last six-digits of the MAC address.
Domain name	Contact your local network administrator for parameter values.	The Ethernet domain name for the network that the meter resides on.

**Stored IPv4 settings available using ION Setup**

Parameter	Value	Description
IP address	Contact your local network administrator for parameter values.	The IP address of your device.
Subnet Mask	Contact your local network administrator for parameter values.	The subnet IP address of your network.
Gateway	Contact your local network administrator for parameter values.	The gateway IP address of your network.

**Stored IPv6 address settings available using ION Setup**

Parameter	Value	Description
Global Address	Contact your local network administrator for parameter values.	The Internet protocol address of your device.
Default Gateway	Contact your local network administrator for parameter values.	The address the meter uses to route communications to a different network or subnet.  If you do not set this or the address is incorrect, you may see slow communications or communications errors.

**ION Setup reconnection**

If you change the settings for the Ethernet connection method you are currently using to connect to the meter, ION Setup tries to reconnect to the meter using the updated information. You can view the process in the **Device reconnection** dialog box that appears.

- If ION Setup can successfully communicate using the new setting, this setting appears in the **IP Address** dropdown list and the checkbox is selected. Click **OK** to copy this information into the **IP address** field in the **Device Properties**. ION Setup will now use this address to communicate with the device.
- If ION Setup cannot successfully communicate using the new setting, the new address appears in the **IP Address** but the checkbox is not selected. Either select the checkbox and click **OK** (for example, you may want to use the new setting if you are replacing a meter in service) OR select another address option from the dropdown list. Click **Test** to check that ION Setup can communicate with the meter using the new address, select the checkbox, then click **OK**.

**Configuring IPv6 communications using ION Setup**

You can use ION Setup to configure the IPv6 communications for the meter.

Contact your network administrator to obtain the IPv6 address information for your meter.

All meters ship from the factory with the IPv6 global address and IPv6 gateway undefined (set to “:”). To communicate with the meter using IPv6 outside the local network, you must configure these settings manually or use DHCP to assign the addresses to the meter. Within the local network, you can use the meter’s IPv6 Link Local address.

When configuring communications parameters, ensure you maintain at least one communication path that allows full access to your device; otherwise you may permanently lose the ability to change your device’s configuration and access to additional data.

## **NOTICE**

### **LOSS OF ACCESS**

**Failure to follow these instructions can result in loss of access to the device.**

Ensure you maintain sufficient access to communicate with and configure your device.

1. Start ION Setup.
2. Open the **Setup Assistant** for your device.
3. Select **Communications > Basic Ethernet**, then click the **IPv6** tab.
4. Select the Link Local address then click **Edit**.
 

**NOTE:** The IPv6 Link Local address itself is factory set and is read-only.
5. Select the **IPv6 Enabled** checkbox to enable IPv6 communications or clear it to disable IPv6 communications.
6. Select your IP address assignment mode.

<b>Selection</b>	<b>Mode</b>	<b>Description</b>
Use DHCP to obtain an IPv6 address	DHCP	The meter acquires its IP addresses from your network's IPv6 DHCP server.
Use the following IP address	Stored	The meter uses the IP addresses that you manually enter for IPv6 (global address and gateway).

You can have different assignment modes for IPv4 and for IPv6.

7. Configure the settings for the selected mode then click **OK**.  
The changes are saved to the meter. If ION Setup detects that the connection information is already in use, you are prompted to confirm the change.

8. Click **Yes** to confirm the change or **No** to cancel.

An example of an instance where you might want to confirm the change is if you are programming the meter to replace another meter already in service.

**DHCP IPv6 settings available using ION Setup**

Parameter	Value	Description
Device name	Contact your local network administrator for parameter values.	The Ethernet device name is used by DPWS for self-discovery over Ethernet and as the hostname to uniquely identify your meter for DHCP and DNS.  By default, this is set to the meter model plus the last six-digits of the MAC address.
Domain name	Contact your local network administrator for parameter values.	The Ethernet domain name for the network that the meter resides on.

**Stored IPv6 address settings available using ION Setup**

Parameter	Value	Description
Global Address	Contact your local network administrator for parameter values.	The Internet protocol address of your device.
Default Gateway	Contact your local network administrator for parameter values.	The address the meter uses to route communications to a different network or subnet.  If you do not set this or the address is incorrect, you may see slow communications or communications errors.

**ION Setup reconnection**

After you change your Ethernet communications settings, ION Setup tries to reconnect to the meter using the updated information. You can view the process in the **Device reconnection** dialog box that appears.

- If ION Setup can successfully communicate using the new setting, this setting appears in the **IP Address** dropdown list and the checkbox is selected. Click **OK** to copy this information into the **IP address** field in the ION Setup **Device Properties** dialog box. ION Setup will now use this address to communicate with the device.
- If ION Setup cannot successfully communicate using the new setting, the **IP Address** dropdown provides a list of connection options, but the checkbox is NOT selected. Select an option from the list then click **Test** to check that ION Setup can communicate with the meter using the new address. Select the checkbox, then click **OK**.

**Configuring general Ethernet settings using ION Setup**

You can configure your device’s general Ethernet settings using ION Setup.

1. Start ION Setup.
2. Open the **Setup Assistant** for your device.
3. Select **Communications > Basic Ethernet** and click the **TCP/IP** tab.

4. Select a setting and then click **Edit**.

**NOTE:** Contact your network system administrator for the appropriate values.

#### General Ethernet settings available using ION Setup

Parameter	Value	Description
Ethernet device name	configurable	This name is associated with your meter when using DPWS. By default, it is the meter type and the last 6 characters of its MAC address.
Rx timeout	configurable	Specifies the number of seconds the meter waits for communication acknowledgments.
Modbus TCP Timeout	configurable	Specify number of seconds the meter waits before disconnecting an idle Modbus TCP connection.
Modbus Gateway	Disabled/COM1	Specify the port on which Modbus Gateway sends/ receives Modbus TCP requests.  <b>NOTE:</b> For Modbus gateway to function properly, the serial port protocol must be set to Modbus Master.
MAC address	Read-only	The media access control (MAC) address is factory set and is for reference only.

## DHCP

The meter can function as a DHCP (Dynamic Host Configuration Protocol) client, allowing a DHCP server to assign IP addresses to the meter.

The meter supports assignment of the following addresses by a DHCP server when the Assignment Mode is set to DHCP:

- IPv4 IP Address
- IPv4 Subnet mask
- IPv4 Gateway
- IPv6 Global Address
- IPv6 Gateway

#### Considerations for using DHCP

- It is recommended that you also set up a DNS server and configure software and other devices to use the meter's name to communicate with it. Alternatively, you can configure the DHCP server to always provide the same address to the meter.
- When you switch the assignment mode from DHCP to Stored, the meter reverts to using its default IP addresses as the Stored addresses.
- When you switch the assignment mode from Stored to DHCP, the acquired addresses display as **None** until the meter receives addresses from the DHCP server.
- When using IPv6, the meter's fully-qualified domain name (FQDN) is not sent to the DHCP server. It is important that you make sure what is configured on the meter matches what is configured on your network.
- If the meter is not able to communicate to the DHCP server:

- When using IPv4, the meter will try to connect to the DHCP server for approximately one minute. If the meter cannot connect to the DHCP server, it will revert to the default IP address, but the Assignment Mode will remain DHCP.
- When using IPv6, the meter will continue to try to connect to the DHCP server, even if it does not receive an address.
- For IPv4, if the meter's fully-qualified domain name (FQDN) is not found on the DHCP server, an event is logged in the event log. For IPv6, if the meter's fully-qualified domain name (FQDN) is not found on the DHCP server, no event is logged; this is important to keep in mind when troubleshooting communications issues in a system using DHCP.

## The meter's domain name

You can configure the meter as a DNS client in systems using a DNS server.

### Domain name resolution (DNS)

A DNS (domain name system) server maps domain names to IP addresses. If you configure the meter to use a DNS server, the meter can communicate with other network resources using their domain names, rather than their IP addresses, and vice versa. For example, if your network has an SMTP server with the domain name of smtp.company.com, you can enter smtp.company.com as the SMTP Server address in the meter's communications settings.

### The meter's fully-qualified domain name (FQDN)

To allow other network resources to communicate to the meter using its domain name, you must configure the meter's Ethernet Device Name setting to match that used by the DNS server. The meter's fully-qualified domain name is its Ethernet name plus its Domain name. For example, if the meter's Ethernet name is ElectricityHQ and its Domain name is companyXYZ.com, the FQDN will be ElectricityHQ.companyXYZ.com.

**NOTE:** This domain name is used for both IPv4 and IPv6 communications. It is used to identify the meter in a system using DNS and to identify the meter when using DPWS for self-discovery over Ethernet.

## Ethernet topologies

When wiring your meter's Ethernet communications, it is recommended to only use straight-line topology.

If local network loop or ring Ethernet topologies are required, you must enable RSTP (rapid spanning tree protocol) for your meter's Ethernet communications to function.

## Network protocol control

The network protocol control feature allows you to enable, disable or change the port number of the network protocols supported on your meter.

Disabling unused ports is considered a cybersecurity best practice to help minimize unauthorized access to your meter.

**NOTE:** The protocol port number may not be configurable on all protocols.

### Configuring network protocol control using the meter display

The Ethernet Port Enable Setup allows you to enable or disable your network protocols through your meter's display.

When configuring communications parameters, ensure you maintain at least one communication path that allows full access to your device; otherwise you may permanently lose the ability to change your device's configuration and access to additional data.

## **NOTICE**

### **LOSS OF ACCESS**

**Failure to follow these instructions can result in loss of access to the device.**

Ensure you maintain sufficient access to communicate with and configure your device.

**NOTE:** You cannot change the Ethernet port number assignments through your meter's display.

1. Press the home button to display your meter's data screen menu.
2. Navigate to **Setup Menu > Ethernet Port Enable Setup**.

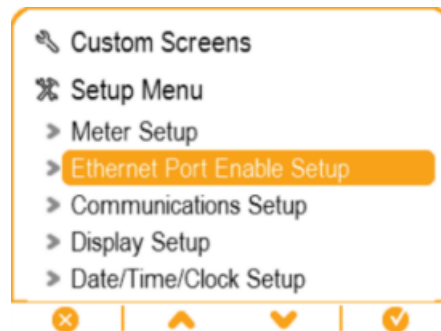

3. Use the up and down arrows to scroll through the Ethernet ports available on your meter. Enabled ports have a  beside them.
4. Press the edit button and provide security credentials if required.

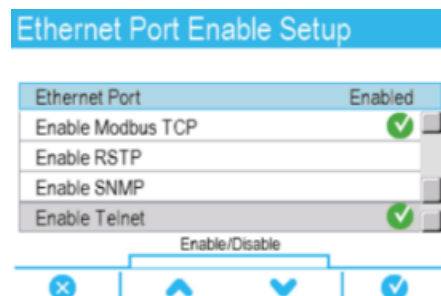

5. Use the up and down buttons to highlight the different Ethernet ports.
6. Press the up and down buttons simultaneously to enable or disable the port.
7. Press the select button when you are finished. Press the select button again at the prompt to accept the changes.

### **Network protocol control using ION Setup**

Use ION Setup to enable, disable or change the port number of the network protocols supported on your meter.

When configuring communications parameters, ensure you maintain at least one communication path that allows full access to your device; otherwise you may

permanently lose the ability to change your device's configuration and access to additional data.

## **NOTICE**

### **LOSS OF ACCESS**

**Failure to follow these instructions can result in loss of access to the device.**

Ensure you maintain sufficient access to communicate with and configure your device.

1. Open the Setup Assistant for your meter.  
See the ION Setup Help for instructions.
2. Select **Communications > Advanced Ethernet** and click the **Protocols** tab.  
Enter your login credentials as required.
3. Select a protocol from the list and click **Edit**.
4. Select the **Enabled** checkbox to enable the port. Clear the checkbox to disable the port.  
**NOTE:** The IEC61850 port is enabled when a valid CID file is uploaded to the meter. The port is disabled by removing the CID file.  
**NOTE:** For EtherGate functionality, the EtherGate protocol must be enabled and the applicable serial port set to **EtherGate**.
5. Select a port number from the **Port Number** dropdown list or by clicking in the **Port Number** field and entering a port number.
6. Click **OK**.

If multiple ports are set to the same number, ION Setup responds with a message indicating that the port is already in use by another protocol.

**NOTE:** When configuring the FTP ports, the data connection port is automatically assigned to the command connection port number minus 1. For example, if the command connection port number is 21, the data connection port number is automatically set to 20.

### **Network protocol control using the meter webpages**

Use the meter webpage to enable, disable or change the port number of the network protocols supported on your meter.

The Setup tab contains configurable elements for enabling, disabling and changing the port numbers for your network protocols.

When configuring communications parameters, ensure you maintain at least one communication path that allows full access to your device; otherwise you may permanently lose the ability to change your device's configuration and access to additional data.

## **NOTICE**

### **LOSS OF ACCESS**

**Failure to follow these instructions can result in loss of access to the device.**

Ensure you maintain sufficient access to communicate with and configure your device.

1. Open a web browser and enter your meter's IP address in the address box.  
The webpage login is displayed.
2. Enter your login credentials.
3. Navigate to **Setup > Ethernet**.
4. Click **Advanced Settings** at the bottom of the screen.
5. Select YES or NO to enable or disable each configurable protocol.
6. Enter the port number for each configurable protocol.
7. Click **Apply** to send these settings to your meter.

## Serial communications

The meter supports serial communication through the RS-485 port.

In an RS-485 network, there is one master device, typically an Ethernet to RS-485 gateway. It provides the means for RS-485 communications with multiple slave devices (for example, meters). For applications that require only one dedicated computer to communicate with the slave devices, a USB to RS-485 converter can be used to connect to the master device.

Up to 32 devices can be connected on a single RS-485 bus.

## RS-485 configuration

Before connecting your device to the RS-485 bus, use the meter's display, webpages or ION Setup to configure your meter's default RS-485 settings.

Your meter has one RS-485 connection.

Your meter must have a unique unit identifier (address) and have the following settings match the rest of the devices on the RS-485 bus:

- Protocol
- Baud rate
- Parity and stop bits

You can configure the following settings to help optimize communications performance:

- RTS delay
- RS-485 bias

You can use a communications converter (USB to RS-485 or RS-232 to RS-485) or an Ethernet gateway device to connect to your meter.

### Serial protocols and ports

Your meter supports serial communications protocols on its RS-485 port.

- ION
- Modbus RTU
- Modbus Master
- DNP 3.0
- EtherGate
- GPS: Truetime/Datum (this protocol setting is for connecting to a GPS receiver communicating in serial ASCII format)

- GPS: Arbiter (this protocol setting is for connecting to a GPS receiver communicating in serial ASCII format)
- GPS: Arbiter-Vorne (this protocol setting is for connecting to a GPS receiver communicating in serial ASCII format)
- None — this protocol setting stops communications using this port

**Related Topics**

- Protocols, ports and connections

**RS-485 Bias**

You can use the RS-485 bias setting to fine tune communications.

Turn on the RS-485 bias when the meter is acting as a master over RS-485 communications and turn off the RS-485 bias when the meter is acting as a slave. You can configure RS-485 biasing through the meter’s display or ION Setup.

**Configuring serial communications using the display**

You can configure your meter’s basic serial communications settings using the display.

Before configuring serial parameters, make sure you have a unique unit ID for your meter and know the serial network settings (protocol, baud rate, parity and stop bits).

1. Go to **Setup Menu > Communications Setup > COM1 Setup**.
2. Configure your meter’s serial settings as required.

**Serial communications settings**

Parameter	Values	Description
Protocol	ION, Modbus RTU, Modbus Master, DNP v3.00, EtherGate, GPS: Truetime/Datum, GPS: Arbiter, GPS: Arbiter-Vorne, Factory, None	Sets the communications protocol for your meter’s RS-485 port  <b>NOTE:</b> the NONE setting stops communications using this port.
Baud Rate	2400, 4800, 9600, 19200, 38400, 57600, 115200	Sets the data rate, in bits per second
Rx Timeout	0 to 1	Sets the transmit delay in seconds
Unit ID	1 to 9999	Sets the meter’s unique ID on the RS-485 network  <b>NOTE:</b> Modbus serial device range 1 to 247
Serial Port	8N1, 8N2, 8E1, 8E2, 8O1, 8O2	Sets the parity and stop bits for the port
RS485 Bias	Off, On	Turns on biasing when mastering devices over the RS-485 port

**Configuring serial communications settings using ION Setup**

You can use ION Setup to configure your meter’s serial communications settings.

Before configuring serial parameters, make sure you have a unique unit ID for your meter and know the serial network settings (protocol, baud rate, parity and stop bits).

1. Start ION Setup.
2. Open the **Setup Assistant** for your device.

3. Select **Communications > Serial Settings** .
4. Select a setting and then click **Edit** to configure the setting to match your communications system.

### Serial communications settings available using ION Setup

Parameter	Values	Description
Protocol	ION, Modbus RTU, Modbus Master, DNP v3.00, EtherGate, GPS: Truetime/Datum, GPS: Arbiter, GPS: Arbiter-Vorne, Factory, None	Sets the communications protocol for your meter's RS-485 port <b>NOTE:</b> the NONE setting stops communications using this port.
Baud Rate	2400, 4800, 9600, 19200, 38400, 57600, 115200	Sets the data rate, in bits per second
Rx Timeout	0.1–15	Sets the transmit delay (timeout for receiving an entire message from a device) in seconds <sup>1</sup>
Unit ID	1 to 9999	Sets the meter's unique ID on the RS-485 network <b>NOTE:</b> Modbus serial device range 1 to 247
Serial Port	8N1, 8N2, 8E1, 8E2, 8O1, 8O2	Sets the parity and stop bits for the port
RS485 Bias	Off, On	Turns on biasing when mastering devices over the RS-485 port

<sup>1</sup>Only applies to a subset of protocols

### Configuring serial communications settings using the webpages

You can use the meter's webpages to configure your serial communications settings.

Before configuring serial parameters, make sure you have a unique unit ID for your meter and know the serial network settings (protocol, baud rate, parity and stop bits).

1. Connect to your meter's webpages using the meter's IPv4 address or its IPv6 link local address, or use self-discovery then double-clicking the meter's network icon.
2. Navigate to **Setup > Serial Port**.
3. Enter the appropriate value for the settings.

- Click **Advanced Settings** to configure additional settings, if needed (for example, RS485 biasing or Rx Timeout).

**Basic serial communications settings available using the webpages**

Parameter	Values	Description
Protocol	ION, Modbus RTU, Modbus Master, DNP v3.00, EtherGate, GPS: Truetime/Datum, GPS: Arbiter, GPS: Arbiter-Vorne, Factory, None	Sets the communications protocol for your meter's RS-485 port <b>NOTE:</b> the NONE setting stops communications using this port.
Baud Rate	2400, 4800, 9600, 19200, 38400, 57600, 115200	Sets the data rate, in bits per second
Unit ID	1 to 9999	Sets the meter's unique ID on the RS-485 network <b>NOTE:</b> Modbus serial device range 0 to 247

**Advanced serial communications settings available using the webpages**

Parameter	Values	Description
RTS Delay	0–1	The delay in seconds before the transmission of the packet.
Rx Timeout	0.1–15	Sets the transmit delay (timeout for receiving an entire message from a device) in seconds <sup>1</sup>
Serial Port	8N1, 8N2, 8E1, 8E2, 8O1, 8O2	Sets the parity and stop bits for the port
RS485 Bias	Off, On	Turns on biasing when mastering devices over the RS-485 port

<sup>1</sup>Only applies to a subset of protocols

**Disabling serial communications to the meter**

**Disabling the COM port using the meter display**

You have the option of disabling the serial communications (COM) port through the meter display when the port is not being used.

Disabling unused ports is considered a cybersecurity best practice to help minimize unauthorized access to your meter.

- Go to **Setup Menu > Communications Setup > COM1 Setup**.
- Press the navigation button to scroll to the **Protocol** entry.

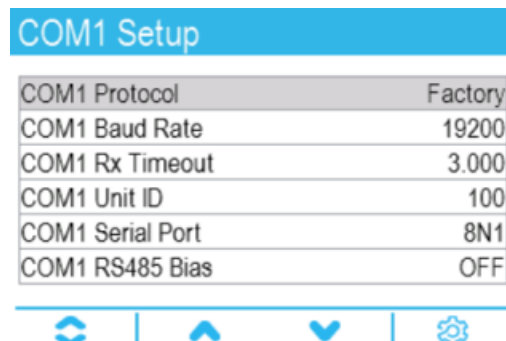

- Press the edit button and provide security credentials if required.

4. Press up or down button and select **None** to disable the port.



5. Press the select button when you are finished. Press the select button again at the prompt to accept the changes.

### Disabling the COM port using ION Setup

You have the option of disabling the serial communications (COM) port through ION Setup when the port is not being used.

Disabling unused ports is considered a cybersecurity best practice to help minimize unauthorized access to your meter.

1. Open the Setup Assistant for your meter. See the ION Setup Help for instructions.
2. Select **Communications > Serial Settings**.
3. Click the **COM** tab for the port you want to disable.
4. Select **Protocol** and click **Edit**.
5. Select **None** from the dropdown list and click **OK**.

### Disable the COM port using the meter webpages

You have the option of disabling the COM port through your meter's webpages when the port is not being used.

Disabling unused ports is considered a cybersecurity best practice to help minimize unauthorized access to your meter.

1. Open a web browser and enter your meter's IP address in the address box. The webpage login prompt is displayed.
2. Enter your login credentials.
3. Navigate to **Setup > Serial Port** and expand the **Basic Settings** section.
4. Select **None** from the **COM Protocol** dropdown list and click **Apply**.

## ION

ION is the native protocol and architecture of your meter.

The basic building blocks of ION architecture are the ION modules, each of which is specialized to perform a specific task and contains data and instructions on how to manage that data. ION modules are combined (linked) together to create the meter's functions and features. ION modules that are linked together to perform a specialized task are called a framework, such as the Power Quality framework. These different

functional frameworks are then grouped together to define the entire meter, and are collectively referred to as the device template.

Your meter ships with a default device template which provides extensive capabilities. You can also configure your meter's template to modify your meter's existing functions or to create new functions.

See the ION Reference, available from [www.usa.siemens.com/pds](http://www.usa.siemens.com/pds) for further information about ION architecture and a detailed description of the different ION modules. See the ION Device Template Reference, available from [www.usa.siemens.com/pds](http://www.usa.siemens.com/pds), for details on the modules and their configuration in your meter's default template.

## Modbus

Modbus is a master/slave communications protocol where the master initiates transactions and the slave(s) responds with the requested information or action.

Your device can function as a Modbus slave or Modbus master, depending on how it is configured. Your device comes with Modbus slave functionality configured and ready to use. You can add custom Modbus information to the default Modbus slave data provided by your device.

### Key terms

Term	Definition
Modbus gateway	A communications method that lets you communicate through an Ethernet gateway device to a Modbus serial network connected to that device.
Modbus master	A device that issues commands and receives responses from Modbus slave devices. Serial Modbus networks can only have one Modbus master per network.
Modbus RTU	Serial Modbus protocol format; Modbus RTU transmits data using binary. Master and slave devices must use the same format.
Modbus register/address	Identifies the data to read/write. Modbus register maps are available for Modbus slave devices and detail the information available from the slave device. More than one register may be used to store a single value.
Modbus slave	A device that responds to Modbus commands and performs actions or provides information back to the Modbus master. Most Modbus networks contain multiple slave devices.
Modbus TCP	The Ethernet Modbus protocol format.
Modbus unit ID	The identifier for a slave Modbus device.

You can download your device's Modbus map from [www.usa.siemens.com/pds](http://www.usa.siemens.com/pds) and get additional information about the Modbus protocol from [www.modbus.org](http://www.modbus.org).

### Modbus best practices for serial

In order for your meter to operate as a serial Modbus device, you must complete some prerequisite configuration.

Prerequisite	Description
Wiring	The device's serial connection must be wired correctly. The Modbus slave devices must have communications wiring to the Modbus master.
Protocol	Slave: for your meter to be a serial Modbus slave, the meter's protocol must be set to Modbus RTU. Master and slave devices must use the same format.

Prerequisite	Description
	Master: for your meter to be a serial Modbus master, the meter's protocol must be set to Modbus Master.
Baud rate	The baud rate must be the same for all devices on the serial Modbus network.
Stop bits and parity	The communication stop bits and parity (for example, 8N1) must be the same for all devices on the serial Modbus network.
Unit ID	Each device on the serial Modbus network must have a unique unit ID (also called the device address).

## Modbus best practices for Ethernet

In order for your meter to operate as an Ethernet Modbus device, you must complete some prerequisite configuration.

**NOTE:** You do not need to perform any Modbus-specific configuration for your meter to function as a Modbus slave device over Ethernet.

Prerequisite	Description
Ethernet	All devices must have a working Ethernet connection.
IP address	All devices must have a unique IP address.
Port	All devices must be communicating over Ethernet port 502 for Modbus TCP.

**NOTE:** Devices supporting multiple simultaneous Modbus TCP connections can have communications delays. Adjust your network timeout settings to accommodate this.

## Configuring your meter for Modbus using the display

You can use the display to configure your meter as a Modbus slave or partially configure your meter for Modbus mastering.

**NOTE:** Your meter's communications must be wired and configured before you begin this procedure.

Your meter does not require any Modbus-specific configuration to act as a Modbus slave device over Ethernet.

1. Navigate to **Setup Menu > Communications Setup** and select the serial communications setup screen.
2. Configure the serial port's Modbus parameters as required.

Parameter	Setting
Protocol	Modbus RTU or Modbus master
RS485 Bias	<ul style="list-style-type: none"> <li>• Off if the meter is a Modbus slave</li> <li>• On if the meter is a Modbus master</li> </ul>

3. Configure the meter's other serial port parameters as required.

For Modbus master, you must add the Modbus slave devices using ION Setup.

### Related Topics

- Meter setup using your meter’s display

## Your meter as a Modbus slave

### Your meter as a Modbus slave on a serial network

Your meter can function as a Modbus slave on a serial network.

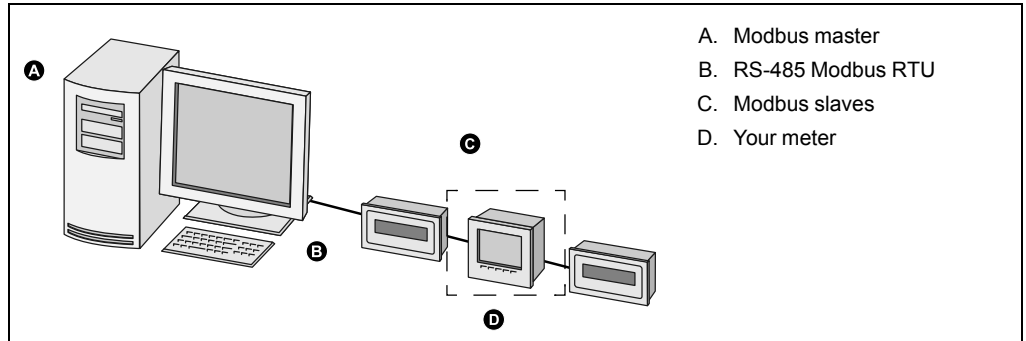

### Your meter as a Modbus slave over Ethernet

Your meter can function as a Modbus slave over Ethernet.

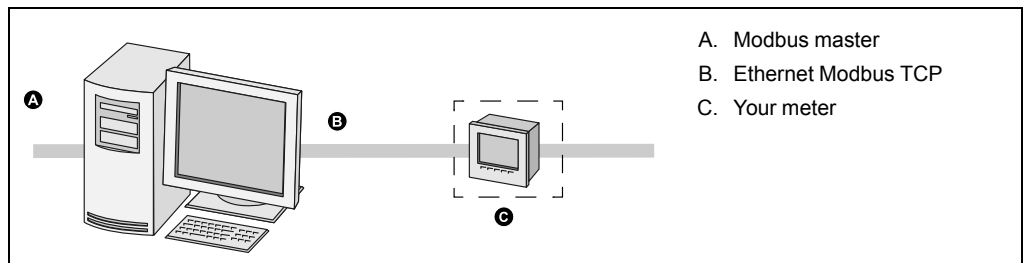

### Configuring your meter as a Modbus slave using ION Setup

You can configure your meter as a Modbus slave using ION Setup.

Your meter’s serial connection must be wired and configured correctly. The same mode of serial communication must be used for all devices on the network.

Your meter does not require any Modbus-specific configuration to act as a Modbus slave device over Ethernet.

1. Start ION Setup.
2. Open the Setup Assistant for your meter.
3. Navigate to **Communications > Serial settings**. Select the tab for the serial port you want to configure.
4. Highlight the parameter and click **Edit** to configure the serial port’s Modbus parameters as required.

Parameter	Setting
Protocol	Modbus RTU or Modbus master
RS485 bias	<ul style="list-style-type: none"> <li>• Off if the meter is a Modbus slave</li> <li>• On if the meter is a Modbus master</li> </ul>

5. Configure the meter’s other serial port parameters as required.

See your device’s Modbus map, available from [www.usa.siemens.com/pds](http://www.usa.siemens.com/pds) for Modbus register information.

## Your meter as a Modbus master

### Your meter as a Modbus master with serial Modbus slave devices

Your meter can function as a Modbus master with serial Modbus slave devices.

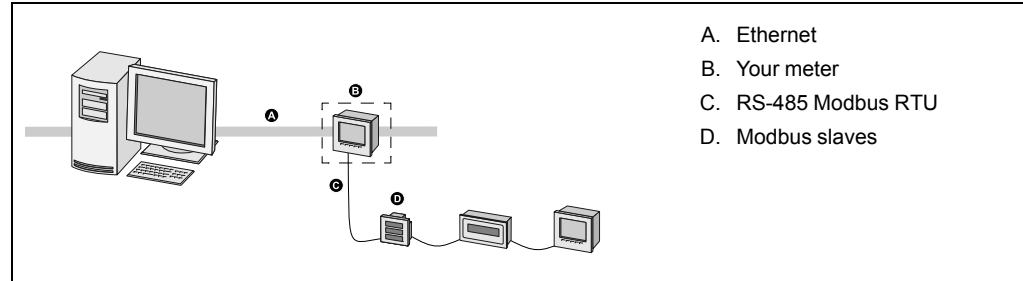

### Your meter as a Modbus master with Ethernet Modbus slave devices

Your meter can function as a Modbus master with Ethernet Modbus slave devices.

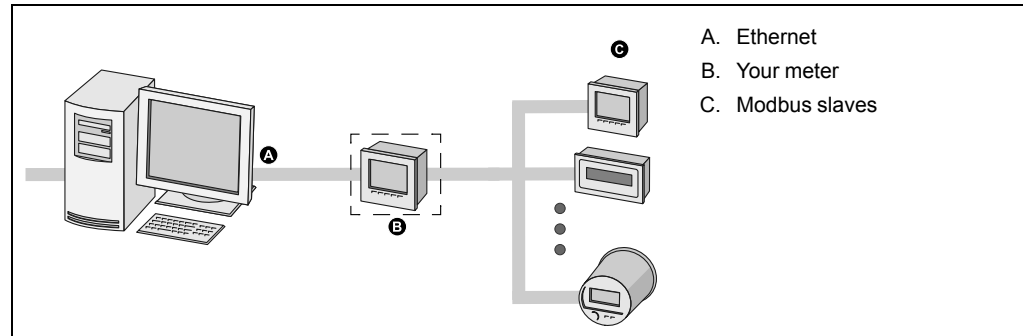

## Modbus master best practices

In order for your meter to operate as a Modbus master, you must complete some prerequisite configuration.

**NOTE:** These settings are required in addition to the serial or Ethernet Modbus prerequisites.

Prerequisite	Description
Modbus slave devices	All Modbus slave devices must be communicating and appropriately configured.
Protocol	<ul style="list-style-type: none"> <li>Modbus mastering serial devices: the master’s serial port protocol must be set to Modbus master.</li> <li>Modbus mastering Ethernet devices: the master must be communicating to the slave devices over Ethernet port 502.</li> </ul> <p><b>NOTE:</b> Having more than one Modbus master on a serial Modbus network may cause communication conflicts.</p>
Mastered devices	The Modbus master device must have the slave device information entered for mastering.

## Configuring your meter as a Modbus master using ION Setup

You can configure your device to Modbus master slave devices over serial or Ethernet.

Make sure your master and slave devices have the prerequisite communications wiring and configuration before configuring your meter as a Modbus master.

If the meter is a Modbus master over TCP/IP, the Modbus TCP/IP and Modbus RTU protocols must be enabled.

**NOTE:** Devices supporting multiple simultaneous Modbus TCP connections can have communications delays. Adjust your network timeout settings to accommodate this.

The meter as a Modbus master over TCP/IP attempts to communicate with a slave device for up to 100 seconds (as per the RFC1122 standard) before moving on to the next slave device.

1. Start ION Setup.
2. Open the Setup Assistant for your meter.
3. Navigate to **Communications > 3rd Party Protocols** and click on the **Modbus Master** tab.
4. Click **Add** to add a Modbus slave device. The Modbus Device dialog appears.
5. Enter the Modbus slave information:
  - Enter the Modbus slave device’s name and a label suffix (if applicable).
  - Select the device type of the slave device from **Device Type**.
  - Enter the unit ID of the Modbus slave device into **Slave ID**.
  - Select the serial or TCP connection from **Connected via**. This is the connection from the Modbus master to the slave device.
6. Click **Connections**. The Modbus Master Connections dialog appears.
7. Select the tab that corresponds to the connection you are configuring (for example, if you selected TCP Connection 1 from **Connected via**, select the TCP 1 tab) and configure it based on the connection type.

Connection type	Configuration
Serial connection	Select the serial communications port that is connected to the Modbus slave devices from the Assigned Port list.
TCP connection	Enter the IP address of the Modbus slave device, making sure that the IP port is set to 502. Make sure that the Modbus RTU and Modbus TCP/IP protocols are enabled.

8. Click **OK** to return to the Modbus Device dialog.
9. Click **OK** to add the slave device. The device now appears on the list. Repeat these steps to add all of your Modbus slave devices.

## Supported Modbus features

Your meter supports specific Modbus data classes, data formats, function codes and commands.

### Modbus data classes

Class	Description
Coils	Digital bits that can be read and written to
Input status	Digital bits that can be read
Input registers	16-bit integers that can be read
Holding registers	16-bit integers that can be read and written to

### Modbus data formats

Format	Type	# of Modbus registers used
Unsigned 16-bit	Integer	1
Signed 16-bit	Integer	1
Unsigned 32-bit	Integer	2
Signed 32-bit	Integer	2
Unsigned 32B-M10K	Integer	2
Signed 32B-M10K	Integer	2
IEEE float <sup>1</sup>	Floating point	2
Packed Boolean for inputs	Integer	1
Packed Boolean for coils	Integer	1
Unsigned 16-bit read/write	Integer	1
Signed 64 bit	Integer	4

<sup>1</sup> Meters acting as Modbus masters support two versions of IEEE float with different word orders: high/low = Big Endian, low/high = Little Endian.

16-bit data (one word) is transmitted with most-significant byte first and least-significant byte second.

32-bit data (two words) is transmitted with the most-significant word first and the least-significant word second.

### Modbus function codes

Function	Description	Master/slave
1	Read coil status	Master and slave
2	Read input status	Master and slave
3	Read holding registers	Master and slave
4	Read input registers	Master
5	Write to a coil	Master
6	Write to a holding register	Master and slave
15	Write to multiple coils	Master
16	Write to multiple holding registers	Master and slave
17	Report slave ID (serial only)	Master and slave
43 (subcode 14)	Read device identification	Master and slave
100	Read scattered holding registers	Master and slave

### Modbus commands

A Modbus master command to unit ID 0 is broadcast (sent to) all Modbus slave devices. The only supported broadcast command is preset multiple registers.

For serial Modbus networks with only one slave device, the master can send commands using the single connection, one-to-one address of unit ID 248, regardless of the slave device's actual unit ID.

## Modbus implementation

Your meter's Modbus implementation includes exception codes, invalid register responses, fixed and configurable register maps, and security.

### Modbus exception codes

Code	Name	Description
01	Illegal function	The requested command is invalid.
02	Illegal address	This code indicates one of the following: <ul style="list-style-type: none"> <li>The requested address is invalid for that function.</li> <li>The requested address is not within the valid register range for this device.</li> <li>The requested address is protected by device security.</li> </ul>
03	Illegal value	This code indicates one of the following: <ul style="list-style-type: none"> <li>The requested value is not allowed for that register in the device.</li> <li>The requested register is part of a multi-word value.</li> </ul>

### Modbus invalid read registers responses

Invalid type	Read response
Unmapped (unused) <sup>1</sup> register	0x8000
Reserved <sup>1</sup> register responses by type	
Signed integer 16-bit	0x8000
Unsigned integer 16-bit	0xFFFF
Signed integer 32-bits	0x80000000
Unsigned integer 32-bits	0xFFFFFFFF
Signed integer 64-bits	0x8000000000000000
Float32	0xFFC00000 (NaN = Not a number)

<sup>1</sup> IRIG-B can only be connected to one of the digital inputs located on the meter base, not an option module. Unmapped (unused) registers are registers that will never be used by the meter, and therefore have no defined format. Reserved registers have a defined format and are intended for use by the meter, its options or its variants.

### Modbus invalid write registers response

If the meter receives a write command to a Modbus register address that does not have a register mapped, the meter does not respond. No data is written or stored, and the meter does not send back a rejection to the request.

If the meter receives a write command to a read-only Modbus register address, exception code 3 (illegal value) is returned.

### Fixed and configurable Modbus map

Your device has a fixed (static) register map for meter data and a flexible, user-configured register map.

### Modbus security

Your meter's onboard security options include Modbus-specific settings. These security settings may need to be configured in order to write Modbus data to the meter.

## Modbus map

Your meter's default Modbus register information (map) is available for download from [www.usa.siemens.com/pds](http://www.usa.siemens.com/pds).

The Modbus register information includes:

- registers and mapped values
- formats and scaling
- additional details where applicable

**NOTE:** Your meter's Modbus registers are specified differently than previous devices using ION architecture. If you are configuring Modbus slave information on your meter, confirm you are using the appropriate Modbus register addressing. Refer to your meter's Modbus map for more information.

Your meter has a fixed (static) register map which contains the most common metering values. This map is defined by a series of Data Mapping modules, which also determine the values shown on your device's display and webpages. The Data Mapping modules are named based on the type of information they map to Modbus:

Data Mapping module	Description
Data Mapping Dmd Modules	Maps kW, kVA and kVAR demand data such as kW sd del (sliding demand kilowatts delivered) as well as current demand such as I a sd (sliding demand phase A current).
Data Mapping Egy Modules	Maps kWh, kVAh and kVARh delivered and received data, including conditional, quadrant and incremental energies.
Data Mapping EN Modules	Maps present interval EN50160 power quality compliance data.
Data Mapping EN Prev Modules	Maps previous interval EN50160 power quality compliance data.
Data Mapping I/O Modules	Maps input metering data, alarms, resets and reset counts.
Data Mapping Meas Modules	Maps measured data from the standard and high-speed Power Meter module. The Cfg Modbus Map Enable setup register may exist in this module.
Data Mapping PQ Modules	Maps power quality data such as Crest Factor, K Factor and total harmonic distortion, including IEC 61000-4-30 power quality compliance data.
Data Mapping Stats Modules	Maps statistical low, mean and high data values, such as I a mean (phase A current average value).
Data Mapping TOU Modules	Maps time-of-use (TOU) data, such as seasons, rates, and per-season demand such as kW sd rec A (sliding demand kilowatts received in season A).

You can add extra Modbus information or duplicate information that is already in the fixed map to different Modbus registers using Modbus Slave modules.

See the ION Reference available from [www.usa.siemens.com/pds](http://www.usa.siemens.com/pds) for detailed information about Data Mapping modules and Modbus Slave modules.

## Configuring custom Modbus data using ION Setup

You can add custom data to your meter's default Modbus map, completely customize your meter's Modbus map, or revert your meter's Modbus map back to its default configuration using ION Setup.

You can download your meter's Modbus map information from [www.usa.siemens.com/pds](http://www.usa.siemens.com/pds).

1. Start ION Setup.
2. Open the Setup Assistant for your meter.
3. Navigate to **Communications > 3rd party protocols** and click on the **Modbus Slave** tab.  
The name of the meter's current Modbus map is displayed, along with the quantity of custom registers and their start and end addresses.
4. Select the map name and click **Edit**.  
The **Modbus Slave Mode Setup** screen is displayed.
5. Select your meter's method of Modbus slave mapping. If you select **Default** or **Disabled**, click **Finish** to configure your meter and return to the Setup Assistant, otherwise select **Next** to access the **Modbus Slave Map Setup** screen.

Option	Description
Default	Sets your meter to use the default Modbus map. Any custom Modbus slave data is removed. <b>NOTE:</b> You can download your meter's Modbus map information from <a href="http://www.usa.siemens.com/pds">www.usa.siemens.com/pds</a> .
Modified	Add Modbus information in addition to the meter's default Modbus map.
Custom	Removes the meter's default Modbus map so that all registers are available so you can create a completely custom Modbus map. <b>NOTE:</b> Use this option if you want to make your meter's Modbus map identical to a device that it is replacing, for example in a retrofit application.
Disabled	Removes your meter's Modbus data map. Modbus functions are unaffected but no meter Modbus data is available.

6. In the **Modbus Slave Map Setup** screen, you can modify parameters by clicking **Edit**, or add parameters by clicking **Add**.  
The **Modbus Register** screen is displayed.
7. Configure the Modbus register information and click **OK** to return to the **Modbus Slave Map Setup** screen.
  - a. **Source:** click **Select** and chose a source from the **Parameter Selection** screen. Select **Show all available registers** to see a complete list of the parameters available on your meter. Click **OK**.
  - b. **Address:** enter the Modbus address that will hold the Source data.  
**NOTE:** If you hover your mouse over the Address field, a tooltip indicates the Modbus function code and start address to send for retrieving the data.
  - c. **Format:** select the Modbus data format from the list.
  - d. **Scaling:** select the scaling value from the list, or select **Custom** and click **Scales** to configure custom scaling.
8. In the **Modbus Slave Map Setup** screen you can click **Delete** to remove a Modbus register, **Set Name** to create a new name for the set of additional data mapped to Modbus, or **Save As** to save the additional data you have mapped to Modbus as a separate file.
9. Click **Finish** to complete your meter's Modbus slave configuration and return to the Setup Assistant.

## Ethernet gateway

Ethernet gateway is a communications method that allows you to communicate through a gateway device to a serial network.

When a meter with gateway capabilities is installed on an Ethernet network, a master device (such as an energy management system) can communicate through the gateway meter to a serial network of devices connected to the gateway meter's serial port(s). The maximum number of devices on the serial network is determined by the limitations of the gateway meter's serial port.

There are two types of Ethernet gateways that you can configure on your meter:

- EtherGate: a single TCP connection communicates through the gateway meter to a serial network of devices.
- Modbus gateway: up to a maximum of 32 Modbus master TCP connections communicate through the gateway meter to a serial network of Modbus devices.

## Related Topics

- Ethernet communications

## EtherGate

The meter can function as an Ethernet gateway (EtherGate).

EtherGate is a protocol-agnostic communications method that lets you communicate through a gateway meter to a serial network of devices letting ION or other RTU over TCP data pass through the gateway meter to other networks, including third party systems. When a meter installed on the Ethernet network has EtherGate enabled, a master device (such as an energy management system) can communicate through the gateway meter to a serial network of devices wired to the gateway meter's COM port. You must create an additional communications connection to the gateway meter in order to read its information.

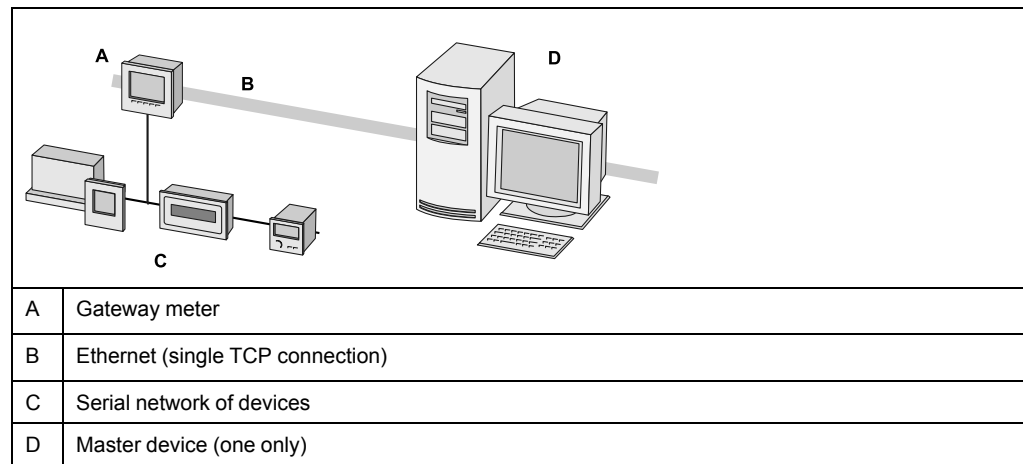

For EtherGate, you must install the serial devices, configure them and connect them to your Ethernet-connected gateway meter. Ensure that each serial device is configured with the same protocol and baud rate and has a unique unit ID. Configure the gateway meter's serial port to use the EtherGate protocol, create the EtherGate site in ION Setup or an energy management system, and add the serial devices to the EtherGate site.

**NOTE:** EtherGate supports only one master device.

### Configuring EtherGate using the display

Use the meter's display to configure a serial port to use the EtherGate protocol.

The Ethergate Ethernet protocol must be enabled for EtherGate operation.

1. Navigate to **Setup Menu > Communications Setup** and go to the serial communications setup screen.

- Set the serial port's protocol to EtherGate. Configure the other serial port parameters as required.

### Configuring an EtherGate gateway using ION Setup

You can configure EtherGate on your meter using ION Setup.

Before you begin, make sure you have completed the following tasks:

- Confirm the serial network of devices are wired and configured to have the same baud rate, serial port settings (for example, 8N1), and protocol (ION).
- Confirm each serial device has a unique unit identifier.
- Confirm the serial network of devices are connected to the gateway meter's serial communication port.
- Confirm your gateway meter is communicating over Ethernet.
- Confirm that the EtherGate Ethernet protocol is enabled on your gateway meter.

- Start ION Setup.
- Open the Setup Assistant for your meter.
- Navigate to **Communications > Serial settings** and select the tab for the communications port that the serial network is connected to.
- Select **Protocol** and click **Edit**. The protocol selection screen appears.
- Set the protocol to **EtherGate**.
- Create an Ethernet gateway site to access the serial network of devices through your gateway meter.

### Modbus Ethernet gateway

The meter's Ethernet gateway feature extends the meter's functionality by allowing Ethernet access to serial devices connected to the meter's RS-485 serial communications port.

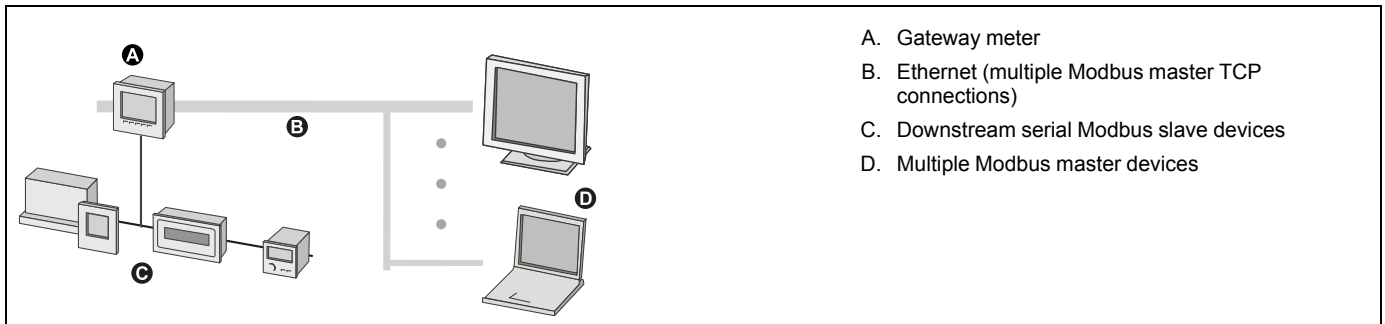

- A. Gateway meter
- B. Ethernet (multiple Modbus master TCP connections)
- C. Downstream serial Modbus slave devices
- D. Multiple Modbus master devices

A Modbus master device (such as an energy management system) can communicate through the gateway meter to a serial network of devices connected to the gateway meter's serial port(s). The meter receives Modbus TCP/IP data on TCP port 502, translates it to Modbus RTU then forwards it to the addressed slave device.

This functionality allows the use of monitoring software to access information from slave devices for data collection, trending, alarm/event management, analysis, and other functions.

### Modbus Ethernet gateway implementation

There are some specific aspects to your meter's Modbus Ethernet gateway implementation.

A Modbus request is sent through Ethernet using Modbus/TCP to the gateway meter. If this request is addressed with the slave ID of one of the downstream serial devices, the meter forwards the message to that device using Modbus RTU. When the downstream device responds, the gateway meter forwards the response back to the Modbus master. In addition to Modbus slave addresses 1 - 247, the Modbus gateway supports slave address 255, which sends a Modbus request to the gateway meter only.

For Modbus gateway, you must install the serial Modbus slave devices, configure them and connect them to your Ethernet-connected Modbus gateway meter. Ensure that each serial device is configured to communicate over Modbus with the same baud rate and has a unique unit ID. Configure the gateway meter's serial port to use the Modbus master protocol and enable the Modbus gateway feature, create a Modbus gateway site in ION Setup or an energy management system, and add the serial devices to the Modbus gateway site.

**NOTE:** Modbus Ethernet gateway supports up to 32 Modbus TCP connections.

### Configuring a Modbus gateway using ION Setup

You can configure Modbus gateway on your meter using ION Setup.

Before you begin, make sure you have completed the following tasks:

- Confirm the serial network of devices are wired and configured to have the same baud rate, serial port settings (for example, 8N1), and protocol (Modbus).
- Confirm each serial device has a unique unit identifier.
- Confirm the serial network of devices are connected to the gateway meter's serial communication port.
- Confirm your gateway meter is communicating over Ethernet.
- Confirm that the Modbus RTU and Modbus TCP/IP Ethernet protocols are enabled on your gateway meter.

1. Start ION Setup.
2. Open the Setup Assistant for your meter.
3. Navigate to **Communications > Serial settings** and select the tab for the communications port that the serial network is connected to.
4. Select **Protocol** and click **Edit**.  
The protocol selection screen appears.
5. Set the protocol to **Modbus Master**.
6. Navigate to **Communications > Basic Ethernet** and select the **TCP/IP** tab.
7. Select **Modbus Gateway** and click **Edit**.  
The Modbus gateway selection screen is displayed.
8. Select the communications port that the serial network is connected to (and you just set to use the Modbus master protocol) and click **OK**. The Modbus gateway connection is created.
9. Create an Ethernet gateway site to access the serial network of devices through your gateway meter.

### Creating an Ethernet gateway site using ION Setup

You can create an EtherGate or Modbus gateway site in ION Setup to view serial devices connected to your meter when it is functioning as an Ethernet gateway.

You must have Ethernet gateway communications configured and your gateway and serial devices connected and communicating.

1. Start ION Setup.
2. Right-click on your workstation icon and select **Insert Item**.  
The **New Network Item** dialog appears.
3. Select **Site** and click **OK**.  
The **New Site** dialog appears.
4. Select the **General** tab and configure the site.

Parameter	Values/Options	Description
Name	-	Ethernet gateway site name
Comm Link	Ethernet	Ethernet communications
Ethernet options	Gateway	Ethernet gateway communications
Gateway Info: IP Addr	—	IP address of the Ethernet gateway meter
Gateway Info: Port	7801, 502	<ul style="list-style-type: none"> <li>• 7801 for EtherGate</li> <li>• 502 for Modbus gateway</li> </ul>

5. Click **OK** to create the site.
6. Right-click on your newly created site and select **Insert Item**.  
The **New Network Item** dialog appears.
7. Make sure your newly created Ethernet gateway site is selected in **Attach to**.
8. Select **Device** and click **OK**.  
The **New Device** dialog appears.
9. Enter the details of your serial device. Click **OK** to add the serial device to your Ethernet gateway site.
10. Repeat for all the serial devices on the gateway meter.

**NOTE:** Use a separate standard Ethernet connection in ION Setup to connect to and read data from your Ethernet gateway meter.

## FTP

Your meter has an internal FTP server that you can use to load files, such as custom webpages, and upgrade your meter and meter accessories.

File transfer protocol (FTP) is a standard, client-server network protocol used to transfer files over TCP (Ethernet) networks.

### Accessing your meter’s FTP server

You must have FTP software such as Filezilla, WinSCP or Windows Explorer running on a Windows-based machine to transfer files to and from your meter’s internal FTP server.

1. Start your FTP software.
2. Connect to your meter via FTP by entering your meter’s IP address. Depending on your FTP software and meter security settings, you may be prompted for login credentials.

**NOTE:** With standard meter security (no user configured), enter login credentials of 9410 and the meter password to connect to the meter. For advanced meter security, enter a valid user and password.

3. Navigate to the appropriate folder on your meter.
4. Close your FTP software to disconnect from the meter. The FTP connection automatically disconnects once the FTP timeout period has elapsed.

## FTP memory allocation

Your meter's FTP memory usage changes when you copy a file to the meter's internal FTP site or modify a feature that uses the meter's FTP site.

If you attempt to load a file onto your meter's FTP site that is too large, your FTP program displays an error, and you must delete files from your meter's internal FTP site to free up memory before loading the file.

If you modify a meter feature which uses FTP memory, such as increasing the number of COMTRADE waveform records, the meter checks to confirm sufficient space is available on its internal FTP site before enabling the modified feature. If there is insufficient space, the feature is disabled, and you must delete files from your meter's FTP site to increase the available space before enabling the feature.

## FTP file structure and permissions

Your meter has an FTP folder structure.

- COMTRADE: you can read COMTRADE files from these folders, but you cannot delete or add files to these folders.
- IEC61850: you can add an IEC 61850 configuration (CID) file to this folder to activate the IEC 61850 protocol functions of your meter.
- optionModuleUpg and rmdUpg: you can load firmware update files for your meter's remote display or option modules into these folders.
- documents: this folder is intended for user storage. You can read, write and delete any type of files in this folder.
- web: this folder is where the meter's default webpages are stored and where you can add custom webpages to the meter by copying them into the appropriate subfolders.

## FTP filename requirements

FTP filenames are limited to standard ASCII characters.

This means that they cannot contain a blank space, quotation marks or \, /, \*, ?, < or >, and are limited to 68 characters in length, including the file extension. The "/" character is only used as part of the FTP file directory information.

## Simple Network Management Protocol (SNMP)

Your meter supports SNMP once you have enabled SNMP on your meter. You need to upload the meter's MIB file (available from [www.usa.siemens.com/pds](http://www.usa.siemens.com/pds)) into the NMS managing your meter.

Simple Network Management Protocol (SNMP) is part of the Transmission Control Protocol/Internet Protocol (TCP/IP) protocol suite. SNMP is an application layer protocol that enables the exchange of network management information between devices, allowing you to manage network performance and to identify and solve problems on networks with devices of various types.

SNMP configuration assumes that you have an advanced understanding of SNMP and the communications network and power system that your meter is connected to.

## Key terms

Term	Definition
Agent	Software resident on the managed device which interfaces between the device and the NMS.
Managed device	Your meter in the SNMP network.
Community name/string	A text string that helps authenticate requests between the managed device and the NMS.
Managed object	Any parameter referenced in the MIB file.
MIB	A management information base which organizes the OIDs in a hierarchical tree.
NMS	A network management station, manager or client that executes applications to monitor and control devices. An NMS must have the standard and custom MIB files and SNMP manager software.
OID	An object identifier that uniquely identifies and labels a managed object in the MIB.
Trap receiver	An NMS that is configured to receive traps and whose IP address is an SNMP trap destination.

## The meter in an SNMP system

Your meter is a managed device with an SNMP agent in an SNMP network.

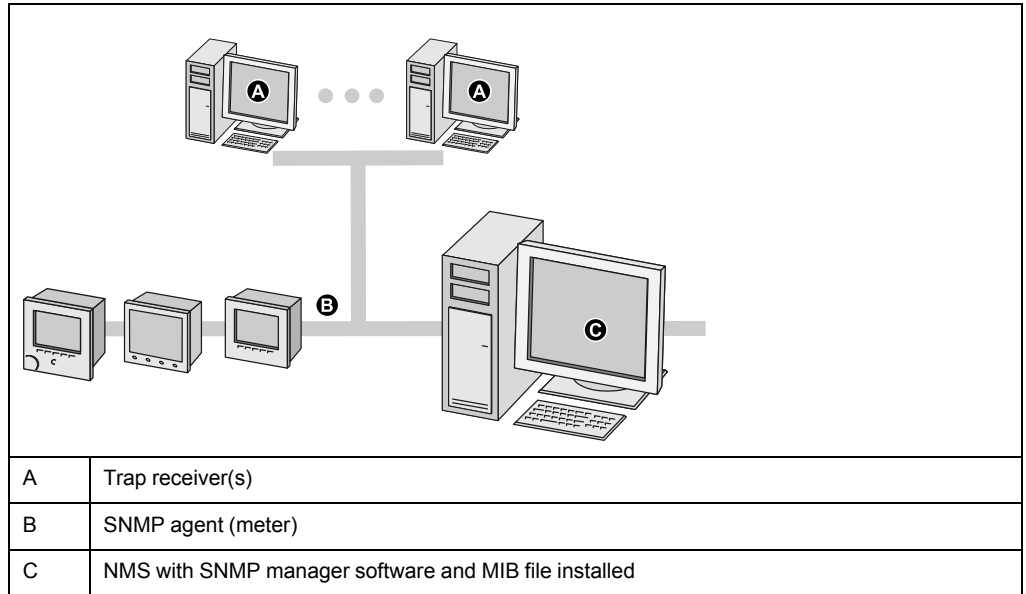

**NOTE:** The NMS computer can also function as a trap receiver.

## SNMP trapping

SNMP trapping allows your meter’s agent to notify the NMS of events with an unsolicited SNMP message (a “trap” of the meter’s alarm event).

You can enter up to four IP addresses for SNMP trap notification for generic and enterprise-specific traps. For enterprise traps, you must also define the number of events or maximum time delay before SNMP traps are sent to the NMS.

SNMP trapping is only supported on SNMP v2.

## Configuring SNMP using ION Setup

You can enable SNMP and configure SNMP trapping using ION Setup.

You must download the ION MIB file from [www.usa.siemens.com/pds](http://www.usa.siemens.com/pds)

1. Start ION Setup.
2. Open the Setup Assistant for your meter.
3. Navigate to **Communications > Advanced Ethernet** and select the **SNMP** tab.
4. Configure your meter's SNMP parameters by selecting the parameter and clicking **Edit**. Click **OK** in the editing screen to set the parameter value.

Parameter	Description
Enable SNMP	Enables or disables SNMP on your meter.
Enable Traps	Enables or disables SNMP trapping on your meter.
Trap Rcvr Addr1 — Trap Recvr Add4	Enter up to four trap receiver IP addresses where trap messages will be sent.
Read only community	Enter the community string used for SNMP get (read-only) requests.
Read write community	Enter the community string used for SNMP set (read/write) requests. <b>NOTE:</b> You can use the read/write community string for SNMP get (read-only) requests.
System contact	Enter the name of your SNMP system administrator.
System name	Enter a descriptive name for your meter.
System location	Enter your meter's location.

5. Review the rest of the SNMP information and modify if necessary.

## Configuring SNMP using your meter's webpages

You can configure SNMP trapping using your meter's webpages.

You must download the ION MIB file from [www.usa.siemens.com/pds](http://www.usa.siemens.com/pds).

1. Connect to your meter's webpages.
2. Go to **Setup > SNMP Parameters**.

### 3. Configure your meter's SNMP parameters by selecting the parameter value.

Parameter	Range	Description
Enable SNMP .	Yes/no	Enables or disables SNMP on your meter.
SNMP Port Number	161 (default)	Enter your meter's SNMP port number.
System contact	—	Enter the name of your SNMP system administrator.
System name	—	Enter a descriptive name for your meter.
System location	—	Enter your meter's location.
Read-only Community Name	—	Enter the community string used for SNMP get (read-only) requests.
Read-write Community Name	—	Enter the community string used for SNMP set (read/write) requests. NOTE: You can use the read/write community string for SNMP get (read-only) requests.
Enable SNMP Traps	Enable/disable	Enables or disables SNMP trapping on your meter.
Enable High Priority Alarms	Yes/no	Enables trapping of events that create high priority alarms.
Enable Med Priority Alarms	Yes/no	Enables trapping of events that create medium priority alarms.
Enable Low Priority Alarms	Yes/no	Enables trapping of events that create low priority alarms.
Report Buffer Size	1 - 30	Enter the maximum number of trap messages to be stored before the trap messages are sent. Traps are sent when the number of trap messages is equal to or greater than this value.
Report Hold Time	1 - 300 seconds	Enter the maximum duration for trap messages to be held. Trap messages are sent when the time after a trap event has occurred is equal to or greater than this value.
Trap Rcvr1 Addr - Trap Rcvr4 Addr	—	Enter up to four trap receiver IP addresses, where trap messages will be sent.

### 4. Click **Apply** to configure the meter's SNMP parameters.

## SNMP implementation

### MIB files

Your meter is compliant with MIB-II as defined by the standard MIB file RFC 1213.

SNMP requires that you load your meter's ION MIB file (available for download from [www.usa.siemens.com/pds](http://www.usa.siemens.com/pds)) into the NMS.

You must install RFC 1213, which is required to read basic network information for the meter (for example, TCP/IP traffic or number of packets received), if it is not included with your SNMP manager software.

### Community strings

A community string is a text string which acts to help authenticate requests from the NMS to your meter.

There are two community strings on your meter:

- **Read Only Community:** this community string is used by SNMP get (read-only) requests. The read only community string's initial factory-set value is **public**.
- **Read Write Community:** this community string is used by SNMP set (read/write) requests. The read write community string's initial factory-set value is **private**.

**NOTE:** You can also use the read write community string for SNMP get (read-only) requests.

If your meter receives an incorrect community string, it generates an AuthenticationFailure trap.

## System strings

A system string is a text string which can be configured to provide information about your meter.

There are three system strings on your meter:

- System contact: enter the name of the SNMP system administrator.
- System name: enter a descriptive name for your meter.
- System location: enter a description of your meter's location.

## SNMP trapping implementation

Generic SNMP traps supported by your meter are:

- Coldstart: the meter (SNMP agent) is starting.
- Linkup: the SNMP agent is enabled.
- AuthenticationFailure: the meter (SNMP agent) has received an incorrect community value.

Enterprise-specific SNMP traps supported by your meter are:

- Low: trap of events with a low event priority.
- Medium: trap of events with a medium event priority.
- High: trap of events with a high event priority.

Trap	Event priority range
Low	64–127
Medium	128–191
High	192–255

**NOTE:** The number of events or maximum time delay settings only apply to enterprise SNMP traps.

See the ION Reference, available from [www.usa.siemens.com/pds](http://www.usa.siemens.com/pds), for detailed information on the SNMP Mapping, SNMP Options and Alarm Options modules.

## Default SNMP mapping

Enabling SNMP provides SNMP access to the meter values linked to the SNMP Mapping module.

You can configure the SNMP Mapping module to link to different meter values. By default, the following meter values are linked to the SNMP Mapping module:

I a	kVAR tot	VII ca	VIn avg	Ib mean	kW sd mx del-rec
I b	kVA tot	VII avg	Freq	Ic mx	kW sd del
I c	PF sign tot	VIn a	Ia mx	Ic mean	kW sd rec
I avg	VII ab	VIn b	Ia mean	kW sd mx del	kW sd del-rec
kW tot	VII bc	VIn c	Ib mx	kW sd mx rec	kVAR sd mx del
kVAR sd mx rec	kVAR sd mx del-rec	kVAR sd del	kVAR sd rec	kVAR sd del-rec	kVA sd mx del

kVA sd mx rec	kVA sd mx del-rec	kVA sd del	kVA sd rec	kVA sd del-rec	kWh del
kWh rec	kWh del-rec	kVARh del	kVARh rec	kVARh del-rec	kVAh del
kVAh rec	kVAh del-rec				

The following meter information is always provided by default and cannot be configured:

Voltsmode	Model number
Serial number	Device name
Firmware version	MIB version

If you change your meter’s default values you must modify the custom MIB file to reflect the new values.

Changing your meter’s default SNMP configuration assumes that you have an advanced understanding of ION architecture, SNMP, and the communications network and power system that your meter is connected to.

See the ION Reference, available from [www.usa.siemens.com/pds](http://www.usa.siemens.com/pds), for detailed information on the SNMP Mapping module.

## Configuring your SNMP MIB file

You must configure your MIB file if you have modified the default SNMP information provided by the meter in order for the MIB file labels to reflect the modified values.

Download the ION MIB file from [www.usa.siemens.com/pds](http://www.usa.siemens.com/pds).

**NOTE:** You should only configure the variable name and description. Changing other fields in your MIB file may cause the client software to report problems or return errors when trying to retrieve or view parameters.

The variable name must conform to the following rules:

- The first character must be a letter.
- The first character must be lower case.
- The name must not contain any special characters such as \*, ?, &.
- The name must not contain spaces.

1. Open your meter’s MIB file in a text editing program (such as Notepad).
2. Update the variable name and description so they match the meter values connected to the SNMP Mapping module.
3. Save your meter’s MIB file. Make sure you keep the original file extension of .MIB.

This example shows an original and an updated OID entry in an MIB file, where the default meter value of voltage line-to-neutral phase A is modified in the meter’s SNMP Mapping module and is now connected to voltage line-toneutral phase C.

Original OID entry
Vln_a OBJECT-TYPE SYNTAX DisplayString (SIZE (0 . 255)) ACCESS read-only STATUS mandatory DESCRIPTION "Host Meter Voltage Line A to Neutral Units = V (Volts)" ::= { Siemens Industry 34 }

You must update the variable name and description to match the meter values connected to the SNMP Mapping module:

Value	Original	Updated
Variable name	VIn_a	VIn_c
Description	"Host Meter Voltage Line A to Neutral Units = V (Volts)" ::= { Siemens Industry 34 }	Host Meter Voltage Line C to Neutral Units = V (Volts)" ::= { Siemens Industry 34 }

The SNMP client software reads the original and updated file as follows:

Original	Updated
variable name: VIn_a Description: "SNM1 Input 1 - Voltage (line-to-neutral) phase A"	variable name: VIn_c Description: "SNM1 Input 1 - Voltage (line-to-neutral) phase C"

## IEC 61850

IEC 61850 is an Ethernet-based protocol designed for electrical substations.

It is a standardized method of communications, developed to support integrated systems composed of multi-vendor, self-describing IEDs (intelligent electronic devices) that are networked together.

Your meter can be integrated into an IEC 61850 system as an IED (or server) supporting concurrent IEC 61850 client connections and an FTP connection (used for transferring data or configuration files).

You can go to the IEC (International Electrotechnical Commission) website at [www.iec.ch](http://www.iec.ch) for information about the IEC 61850 protocol. For more information on how IEC 61850 is implemented on your meter, see the *IEC 61850 and ION Technology* protocol document.

### IEC 61850 implementation

Your meter comes configured with a default set of meter data available to IEC 61850.

This default set of meter data is used in the default data sets and reports in the ICD file (s) available for download from [www.usa.siemens.com/pds](http://www.usa.siemens.com/pds).

**NOTE:** Select the ICD file that matches your meter's option module configuration.

You must load a valid IEC 61850 configuration (CID) file into the meter's internal FTP site in order to activate the IEC 61850 features of your meter. Your meter can have only one IEC 61850 configuration (CID) file loaded onto its internal FTP storage. If additional CID files are loaded, IEC 61850 functions are deactivated until the additional files are removed.

**NOTE:** IEC 61850 is not supported over IPv6.

You can load the IEC 61850 configuration file and configure the IEC 61850 custom modules using ION Setup.

### Related Topics

- FTP

### Loading an IEC 61850 configuration file using ION Setup

You can load an IEC 61850 configuration (CID) file using ION Setup over an Ethernet connection.

You must have:

- The IEC 61850 configuration file stored in a location accessible by ION Setup. The configuration file is created by customizing the IEC 61850 device (ICD) file, which can be downloaded from [www.usa.siemens.com/pds](http://www.usa.siemens.com/pds).
- FTP access to your meter from the computer running ION Setup.

**NOTE:** Your meter can have only one IEC 61850 configuration (CID) file loaded onto its internal FTP site. If additional CID files are loaded, IEC 61850 functions are deactivated until the additional files are removed.

1. Start ION Setup.
2. Open the Setup Assistant for your meter.
3. Navigate to **Communications > 3rd Party Protocols** and select the **IEC 61850** tab.
4. Highlight a parameter and click **Upload**. Navigate to where you stored your meter's CID file, select the file, and click **Open**.

Your meter reviews the CID file to determine if it is valid. This process may take several minutes.

The CID status indicates whether the meter has received and validated an IEC 61850 CID file and is operating as an IEC 61850 server.

## Configuring additional data for IEC 61850 using ION Setup

You can map additional data to IEC 61850 using ION Setup.

You must have a valid IEC 61850 configuration file loaded onto your meter for IEC 61850 functionality, but it is not necessary for configuring additional data.

**NOTE:** You can configure additional data at any time, whether or not IEC 61850 is operating on your meter.

1. Start ION Setup.
2. Open the Setup Assistant for your meter.
3. Navigate to **Communications > 3rd Party Protocols** and select the **IEC 61850** tab.
4. Select the information type that corresponds to the type of meter information that you want to add to your IEC 61850 data. Select analog for numeric information and digital for boolean or binary information. Click **Edit**. The custom configuration screen is displayed.
5. Select the desired meter value from those available. If the value you want is not shown, select **Show all available registers**.
6. Select an IEC 61850 leaf to associate with the meter data, and click **>>** to map the value. Click **<<** to unmap values. Click **OK** to send and save your changes to the meter.

## Configuring digital outputs for IEC 61850 control using ION Setup

You can configure your digital outputs so that they can be used for non-critical control via IEC 61850.

Your meter has a comprehensive default implementation of IEC 61850 which meets the needs of most systems with only basic configuration. You can customize this implementation so that IEC 61850 can be used to control your meter's digital outputs;

this is an advanced procedure that requires in-depth knowledge of your meter, its underlying architecture, and the system in which it is installed.

## ▲ WARNING

### UNINTENDED OPERATION

**Failure to follow these instructions can result in death, serious injury, or equipment damage.**

Do not use this device for critical control or protection applications where human or equipment safety relies on the operation of the control circuit.

1. Start ION Setup.
2. Connect to your meter in advanced mode.
3. Navigate to the GGIO Onboard folder and double-click on the module in the righthand pane.
4. Select the **Setup Registers** tab.
5. Select the *SPCS Control Mode* register that corresponds to the digital output you want to control through IEC 61850 and click **Edit**. A dialog appears.
6. Select IEC 61850 CTLVAL from the dropdown list and click **OK**.
7. Select the **Inputs** tab.
8. Select the digital output Status register for the digital output that you want to control through IEC 61850. Click **Delete**.
 

**NOTE:** This digital input register must be deleted in order to prevent a circular reference that will cause the affected modules to go offline.
9. Click **Send** to send your changes to the meter.
10. Select the **Setup Registers** tab and confirm that the Digital Output module's setup registers are appropriately configured.
11. Select the **Inputs** tab.
12. Select the *Source* register and click **Edit**.
13. Navigate to the IEC 61850 GGIO Onboard folder and select the *SPCS.stVal* output register that corresponds to the digital output.
14. Click **OK** and **Send** to save your changes to the meter.

See the ION Reference, available from [www.usa.siemens.com/pds](http://www.usa.siemens.com/pds), for information about the IEC 61850 GGIO and Digital output modules.

## DNP

Your meter can be integrated into a DNP network as a DNP slave.

The Distributed Network Protocol Version 3.0 (DNP 3.0) is an open protocol used in the electric utility industry for communications and interoperability among substation computers, Remote Terminal Units (RTUs), Intelligent Electronic Devices (IEDs, e.g. meters), and master stations.

### DNP supported features and default implementation

Your meter is pre-configured for basic DNP Slave functionality.

Your meter supports a maximum of three concurrent connections (sessions) using the DNP 3.0 protocol; one for each serial port, up to three using Ethernet, or a combination of both. Combinations available depend on the meter's communications options. A session consists of all incoming and outgoing DNP Master/Slave traffic on one of the meter's communications ports.

For serial DNP communications, you must assign the DNP protocol to the appropriate serial communication port on your meter; you do not have to configure your meter's Ethernet port(s).

You can modify your meter's default DNP map using configuration software.

Data can be imported into the meter from a DNP control relay or analog output device. This is an advanced feature intended for users with an in-depth understanding of the DNP 3.0 and ION protocols.

See the online ION Setup help for instructions on connecting to your meter and accessing the Setup Assistant, which can be used to modify your meter's DNP port settings and default DNP map. Go to [www.usa.siemens.com/pds](http://www.usa.siemens.com/pds) to download your meter's DNP 3.0 device profile document for detailed information on your meter's default DNP map and implementation and the *Multiport DNP 3.0 and ION technology* technical note for more information on how your meter supports DNP 3.0.

# Time and timekeeping

## Time overview

Your meter supports different time types and time synchronization methods to adjust its internal clock.

Your meter's internal clock is used for keeping time, timestamping data and determining intervals for time-based measurements. The meter's clock does not affect externally logged data.

Your meter monitors the passage of time using the frequency of an internal oscillator or the frequency of the line power being measured. You can view your meter's time and date information using the display or through software. To improve your meter clock's accuracy, you can use an external time reference, such as a Global Positioning System (GPS) signal.

Your meter's battery maintains the internal clock when the meter is unpowered.

Your meter displays local time based on the meter's time sync source and settings for timezone and daylight savings time. You can configure your meter's date and time format.

Go to [www.usa.siemens.com/pds](http://www.usa.siemens.com/pds) and download the *Time synchronization and timekeeping* technical note for more information about time formats and settings and the *ION Reference* for a detailed description of the Clock module and its operation.

## Internal clock temperature compensation

The time accuracy of the meter has been improved by compensating for clock drift if the meter's operating temperature falls outside the optimum temperature range.

Your meter's internal clock is adjusted based on the internal clock temperature compensation parameters.

### Internal clock temperature compensation parameters

Your meter's internal clock is adjusted based on the temperature profile of its components.

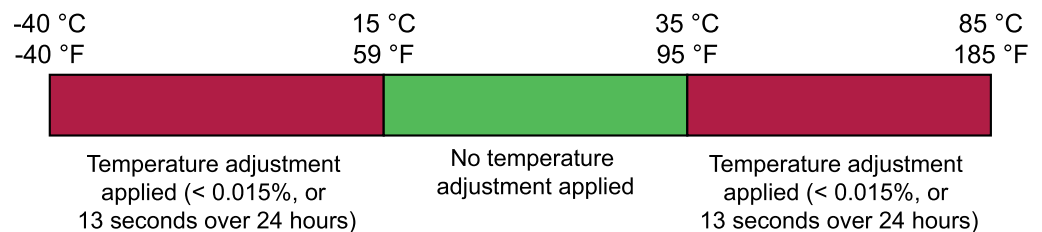

## Time synchronization overview

The time synchronization source and the duration between time synchronization messages determines the accuracy of the meter's clock.

The clock is adjusted by synchronizing the meter's time with another time source. Time synchronization messages can be automatically generated and sent to your meter from your energy management system software or other time source such as an SNTP/NTP server or GPS receiver. You can also manually trigger a time

synchronization message from your energy management system or configuration software.

**NOTE:** To help maintain data integrity, some energy management systems impose a blackout rule where time synchronization messages near energy interval boundaries are ignored.

## Supported time synchronization sources

Several time synchronization sources are available to your meter.

Time sync source	Description
Meter configuration software (ION Setup)	Configuration software can manually synchronize the time of your meter based on the clock of the computer running the configuration software. Configuration software synchronization is usually performed when the meter is initially commissioned.
Energy management system	Energy management systems can synchronize the time of your meter to be consistent with other meters on the network.
Simple Network Time Protocol (SNTP)	SNTP can synchronize the time of your meter up to $\pm 1$ second of other meters on an Ethernet network. For SNTP time synchronization, your meter must be connected to an Ethernet network that has an active SNTP server and be configured with the server's information.
GPS receiver (IRIG-B) <sup>1</sup>	A GPS receiver using IRIG-B can synchronize the time of a meter up to $\pm 1$ ms of Coordinated Universal Time (UTC). A dedicated serial network is required to implement a GPS scheme. For IRIG-B, one of your meter's digital inputs must be connected to the IRIG-B network, and the digital input must be configured for IRIG-B time synchronization in addition to configuring your meter's clock.
GPS over serial	A GPS receiver can synchronize the time of a meter up to $\pm 1$ ms of Coordinated Universal Time (UTC). For GPS over serial, your meter's serial port must be connected to a GPS receiver, and the serial port communications must be configured with the correct protocol setting.
Network Time Protocol (NTP)	NTP can typically synchronize the time of a meter to $\pm 10$ to 100 ms, depending on network configuration. To implement NTP time synchronization, your meter must be connected to an Ethernet network that has an active NTP server and be configured with the server's information.

<sup>1</sup> Use the digital inputs located on the meter base for IRIG-B time synchronization and other high-accuracy applications.

## GPS time quality flag

The meter's GPS time quality flag is primarily used to report time quality information for digital input events, such as status alarms, in Sequence-of-Events Recording (SER) applications.

The meter keeps track of the time difference between the meter's internal clock and the GPS time sync source. When the meter's Clock module's *Use GPS Quality Flag* is set to `USE_FLAG`, the Diagnostics module's *GPS Receiver Status* output register is set to:

- `LOCKED` if the time difference between the GPS time sync source and meter clock is within  $\pm 1$  ms of each other

- UNLOCKED if the time difference between the GPS time sync source and meter clock is greater than  $\pm 1$  ms of each other

## Configuring time information using your meter's display

Use the meter's display to configure a variety of time parameters.

1. Go to **Setup Menu > Date/Time/Clock Setup > Date & Time Setup**.
2. Configure your time and date formats, time zone offset, and daylight savings time offset. Press the down button to access the **Clock Setup** screen.
3. Configure the clock and time synchronization source, and the time synchronization time format.

### Date & time setup

Parameter	Values	Description
Time Format	12 H, 24 H	Specifies how the time is displayed
Date Format	MM/DD/YYYY, DD/MM/YYYY, YYYY/MM/DD	Specifies how the date is displayed
TZ Offset	-12:00:00 to 12:00:00	Sets the time zone of the meter's location, relative to UTC
DST Offset	-3:00:00 to 3:00:00	Sets the daylight savings time offset of the meter's location

### Clock setup

Parameter	Values	Description
Clock Source	Internal, Line Freq, COMM	Specifies the time synchronization source
Time Sync Source	COM1, Ethernet, Ethernet - ION, Ethernet - DNP, IRIG-B	Specifies the port to receive time synchronization signals
Time Sync Type	UTC, Local	Specifies whether time synchronization signals are received in local time or UTC

## Date/Time/Clock setup

You can configure your meter's date, time and clock parameters using the display.

### Date & time setup

Parameter	Values	Description
Time Format	12 H, 24 H	Specifies how the time is displayed
Date Format	MM/DD/YYYY, DD/MM/YYYY, YYYY/MM/DD	Specifies how the date is displayed
TZ Offset	-12:00:00 to 12:00:00	Sets the time zone of the meter's location, relative to UTC
DST Offset	-3:00:00 to 3:00:00	Sets the daylight savings time offset of the meter's location

### Clock setup

Parameter	Values	Description
Clock Source	Internal, Line Freq, COMM	Specifies the time synchronization source
Time Sync Source	COM1, Ethernet, Ethernet - ION, Ethernet - DNP, IRIG-B	Specifies the port to receive time synchronization signals
Time Sync Type	UTC, Local	Specifies whether time synchronization signals are received in local time or UTC

## Configuring time and time synchronization using ION Setup

You can set the time and date and configure the time synchronization settings using ION Setup.

**NOTE:** The clock screen is where you set the start day of the week for the time of use feature.

**NOTE:** You must manually adjust the date and time information if the device is installed in a different time zone location from the computer running ION Setup.

1. Start ION Setup.
2. Open the Setup Assistant for your device.
3. Navigate to **Clock** and select the **Timezone** tab.
4. Select any parameter and click **TimeSync** to synchronize your device's date and time with the computer that is running ION Setup.
5. Click the **DST Settings** tab to modify your meter's daylight savings time start and end dates, if required.

6. Select the parameter that you want to configure and click **Edit**. Enter the password if prompted.

Parameter	Value	Description
Timezone	–	Sets the timezone based on the timezones available from the computer's operating system. <b>NOTE:</b> This is also where you can synchronize your meter's DST settings with the computer's.
Time sync type	Local time or UTC	Specifies the time format of the time sync message: <ul style="list-style-type: none"> <li>UTC: Coordinated Universal time: for the purposes of meter configuration, it is equivalent to Greenwich Mean Time (GMT).</li> <li>Local time: the local time, with DST and timezone information applied.</li> </ul>
Time sync source	COM1, Ethernet, Ethernet - ION, Ethernet - DNP, IRIG-B	Sets which device port accepts time synchronization messages. Time synchronization messages on other ports are ignored.
Clock Source	Internal, Line frequency, COMM	Sets the source for the clock: <ul style="list-style-type: none"> <li>Internal: the meter's internal clock.</li> <li>Line frequency: the frequency of the measured power system as the clock source.</li> <li>COMM: the meter's communication port (used by the GPS time sync source).</li> </ul>
DST Offset	Numeric Bounded Format/ Elapsed Interval Format	Specifies the amount of time the meter clock is moved forward when entering Daylight Savings. A value of zero disables this feature and clock does not adjust for DST.
Start of the Week	Monday - Sunday	Specifies the start day of the week used for Trending and Forecasting. <b>NOTE:</b> Changing the start day of the week clears all trending and forecasting data.

For SNTP/NTP time synchronization, you must set the **Time sync type** to **UTC** and the **Time sync source** to **Ethernet**.

For GPS/IRIG-B time synchronization, you must set the **Time sync source** to **IRIGB** and the **Clock Source** to **COMM**.

7. For SNTP/NTP time synchronization, you must also enter the following information under **Communications > Advanced Ethernet > NTP**:

Parameter	Value	Description
Enable NTP Time Sync	NTP, SNTP, No	NTP: specifies NTP time synchronization. SNTP: specifies SNTP time synchronization. <b>NOTE:</b> SNTP is recommended for revenue-related applications. No: neither NTP nor SNTP time synchronization are used.
NTP Time Sync Interval	Numeric value or elapsed interval value	Specifies how often the meter synchronizes over SNTP. <b>NOTE:</b> This parameter is not used for NTP.
NTP Event Logging Threshold (NTP only)	1000 to 1000000	Specifies the minimum time difference (in milliseconds) for a time synchronization to be logged as an event. This parameter can be configured to help prevent the meter's event log from being flooded with time synchronization events.
NTP Server	Server IP address or domain name	Specifies the IP address (or fully qualified domain name if DNS is active) of the SNTP or NTP server.

8. For serial GPS time synchronization, you must also enter the following information under **Communications > Serial** settings:

Parameter	Description
Protocol	Select the GPS setting that matches your GPS receiver.
Baud rate	The recommended baud rate for GPS time synchronization is 9600 bps.
Serial port	The recommended stop bits/parity for GPS time synchronization is 8N1.

# Maintenance

## Firmware and templates

### Firmware and template overview

You can load different firmware versions and templates onto your meter.

Firmware is your meter's operating system that enables the functions of your meter. Your meter's template defines the meter's features such as its power measurement and analyzing functionality. Your meter ships from the factory with a default template, or you can customize your meter's template to create features specific to your meter's application. You can save your customized template and upload it to other meters of the same type.

You can view your meter's firmware version on your meter's display, webpages and through ION Setup.

You can upgrade your meter's firmware and template using ION Setup. Firmware updates and new factory templates are available for download from [www.usa.siemens.com/pds](http://www.usa.siemens.com/pds).

### Firmware overview

Firmware is your meter's operating system.

When new firmware is available for your meter, you can upgrade to the latest version to get the added features and functionality. The firmware version loaded on your meter is shown on your meter's display. You can use ION Setup to upgrade the firmware on your meter.

You must load a meter template as part of the firmware upgrade process. You can save your meter's existing framework before performing a firmware upgrade and then reload it back onto the meter if you do not want to change your meter's template.

Your meter's remote display and option module use firmware information from the meter, but they may also need to have their internal firmware updated if internal components change. To load and update to your meter's remote display firmware, you need to copy the file to your meter's internal FTP server. You can download firmware files from [www.usa.siemens.com/pds](http://www.usa.siemens.com/pds)

See the online ION Setup help, available from [www.usa.siemens.com/pds](http://www.usa.siemens.com/pds), for more information on downloading, saving and loading your meter's template.

### Typical workflows

To update your meter to the latest available firmware and factory template:

- Download the latest firmware and template for your meter.
- Load the firmware onto your meter; the firmware upgrade process includes upgrading the meter template.

To take an existing meter out of service and replace it with a new meter:

- Save the template from the existing meter
- Load the existing meter's template onto the new meter; the new meter will now have the customized features from the existing meter.

To update your meter's firmware without updating your meter's template:

- Save your meter's template.
- Download the latest firmware.

- Load the firmware onto your meter. When prompted for a template file, select the template you saved from your meter.

To update the firmware on your meter's remote display:

- Download the display firmware.
- Load the firmware onto the meter's internal FTP site using either an FTP program or ION Setup. The results of the firmware update are stored in the meter's event log.

To update the firmware on your meter's option module(s):

- Download the option module firmware; make sure that the firmware matches the option module type.
- Load the firmware onto the meter's internal FTP site using either an FTP program or ION Setup.
- Power cycle or perform an option bus reset to start the option module firmware

**NOTE:** If the meter is power cycled or an option module reset is performed while there are option module firmware upgrade files loaded on the meter's FTP site, the option module firmware is upgraded.

Visit the company website at [www.usa.siemens.com/pds](http://www.usa.siemens.com/pds) and search for your meter type to see the available firmware and templates.

See the online ION Setup help for instructions on how to load meter templates.

## Laptop computer upgrade considerations

The connection between the laptop and the device must be maintained in order for the upgrade to proceed.

Laptop computers generally have different default power properties than desktop computers.

If the laptop's hard disk shuts down or the laptop enters system standby mode, this connection is broken and the upgrade procedure must be restarted.

If you are upgrading your meter's firmware using a laptop computer, follow these guidelines:

- Plug the laptop computer into a wall outlet. Do not run the laptop on its battery.
- Configure the laptop's hard disks so that they do not shut down after a certain period of time (for example, set to "never").
- Turn off the laptop's power suspension (for example, system stand-by) and hibernate options.
- Disable the laptop's option to power down when it is closed. This prevents a shut down if the laptop is accidentally closed.
- Disable the laptop's screen saver as they can burden the CPU.

## Firmware upgrade considerations

Ensure that the firmware version you are upgrading to is compatible with your meter, and that the version number is greater than your existing firmware (or else you will downgrade your meter).

Your meter's existing template may not work with different firmware versions if significant meter features have been added or modified.

Your firmware upgrade files have digital signature confirmation to help ensure your firmware's authenticity. Once you have upgraded your firmware to a version that uses digital signature confirmation, you cannot downgrade to an earlier firmware version that did not use digital signature authentication.

### Remote display (RMD) upgrade behavior

Your meter's remote display will upgrade as soon as the upgrade file is put in the remote display upgrade folder on your meter's internal FTP site. It is deleted as part of the upgrade process.

**NOTE:** If your meter's remote display loses power during firmware upload, the display will revert to its original firmware and you will have to reload the firmware file.

The results of your remote display firmware upgrade are stored in your meter's event log. Detailed information about your remote display, such as serial number and firmware version is provided in the Factory module.

See the *ION Reference*, available from [www.usa.siemens.com/pds](http://www.usa.siemens.com/pds), for more information about the Factory module.

### Option module(s) upgrade behavior

To upgrade option modules, you must load the upgrade file into the appropriate folder on the meter's internal FTP site. The upgrade is triggered by either a power cycle or option module reset. After the upgrade is performed, the upgrade file is deleted from the meter's internal FTP site before the option module is reset to run the new firmware. The option module firmware will not upgrade if more than one upgrade file is in the folder. The upgrade file must be the correct file type and match the type of module being upgraded.

All option modules do not perform their regular functions during firmware upgrade. If more than one option module is being upgraded, the firmware on the option module closest to the meter is done first, then the next closest, proceeding to the furthest module from the meter base requiring upgrading. A single option module firmware upgrade should not take more than five minutes.

The option module upgrade results are stored in your meter's event log. Detailed information about the option module, such as serial number and firmware version is provided in the Factory module. Information about the option module type and details of the option module's state is provided in the Diagnostics module.

See the *ION Reference*, available from [www.usa.siemens.com/pds](http://www.usa.siemens.com/pds), for more information about the Factory and Diagnostic modules.

## Loading meter firmware using ION Setup

You can load firmware onto your meter using ION Setup.

You can download firmware for your meter from [www.usa.siemens.com/pds](http://www.usa.siemens.com/pds).

You must load a meter template as part of the firmware upgrade process. You can save your meter's existing template by navigating to **Template > Save to PC** in the ION Setup Assistant and clicking **Save** to save your meter's template as a .DCF file. You can also use a template that you have saved from another meter of the same type, or download a factory template from [www.usa.siemens.com/pds](http://www.usa.siemens.com/pds).

Ensure that you record your meter's user and password information in a secure location before upgrading the meter's firmware. If your meter's user and password information is lost, you must return the meter for factory reconfiguration, which resets your meter to its factory defaults and destroys all logged data.

Any digital and analog outputs associated with your device may change state during a firmware upgrade.

## ▲ WARNING

### UNINTENDED OPERATION

**Failure to follow these instructions can result in death, serious injury, or equipment damage.**

Do not use this device for critical control or protection applications where human or equipment safety relies on the operation of the control circuit.

Loading firmware or template onto your meter clears the meter's recorded data.

## NOTICE

### DATA LOSS

**Failure to follow these instructions can result in data loss.**

Ensure that all important data has been recorded before uploading firmware or a template to your device.

1. Obtain the meter firmware (.UPG) and framework (.DCF) that you want to load onto your meter. Save the files where they can be accessed by the computer running ION Setup.
2. Start ION Setup.
3. Open the Setup Assistant for your meter.
4. Select the **Template** screen.
5. Click the **Firmware Upgrade** tab, then click **Upgrade**. Enter your meter's password (if prompted) and click **OK**.
 

**NOTE:** If you want to retain customized meter template settings, other than those listed in the Template Paste Options dialog box (see Step 8), click on the **Save to PC** tab and click **Save**. Save your template as a .DCF file. Select this file in Step 7 instead of the file obtained from the website.
6. Navigate to the meter firmware (.UPG) file and click **Open**. Enter your ION Setup password when prompted and click **OK**.
7. Navigate to the meter framework (.DCF) file and click **OK**. The Template Paste Options dialog box appears.
8. Select the check boxes for the settings you want to retain (not overwrite) and click **OK**.

A dialog box describes the template upload and firmware upgrade progress, verifies the firmware, and finishes with an overview stating whether the firmware and framework were successfully uploaded onto your meter.

#### Post-requisite:

After upgrading your meter's firmware or template, make sure that the meter's settings, either for existing functionality or new features, are appropriate for your system.

## Loading option module firmware using ION Setup

You can upload firmware to your meter's option modules using ION Setup over an Ethernet connection.

You can only upload firmware to the same type of module; if you have different types of option modules connected to your meter, you must perform the upload process for each module type.

You must have:

- Your meter's option module firmware upgrade (.SI9) file. You can download upgrade files from [www.usa.siemens.com/pds](http://www.usa.siemens.com/pds).
- The option module connected to your meter, and have access to your meter's internal FTP site.
- FTP access to your meter from the computer running ION Setup.

All option modules do not perform their regular functions during firmware upgrade; they will not communicate to the meter and the outputs may change state during the upgrade process.

## **▲ WARNING**

### **UNINTENDED OPERATION**

**Failure to follow these instructions can result in death, serious injury, or equipment damage.**

Do not use this device for critical control or protection applications where human or equipment safety relies on the operation of the control circuit.

1. Obtain the option module firmware (.SI9) files that you want to load onto your option module(s). Save the files where they can be accessed by the computer running ION Setup.
2. Start ION Setup.
3. Open the Setup Assistant for your meter.
4. Select the **Template** screen.
5. Click the **Firmware Upgrade** tab, then click **Upgrade**. Enter your meter's password (if prompted) and click **OK**.
6. Navigate to where you have stored the option module firmware. Select the Option Module firmware file (\*.SI9) as the file type.
7. Select the option module firmware (.SI9) file and click **Open**.
8. Enter your ION Setup password when prompted and click **OK**.

A dialog box describes the firmware upgrade progress, verifies the firmware, and finishes with an overview stating whether the firmware was successfully uploaded.

## **Loading remote display firmware using ION Setup**

This procedure is specific to the DIN meters with a remote display, and cannot be performed on meters with an integrated display.

You can load updates to your meter's remote display firmware using ION Setup over an Ethernet connection.

You must have:

- Your meter's remote display firmware update (.BIN) file. You can download update files from [www.usa.siemens.com/pds](http://www.usa.siemens.com/pds).
- The remote display connected to your meter.
- FTP access to your meter from the computer running ION Setup.

**NOTE:** If your meter's remote display loses power during firmware upload, the display will revert to its original firmware and you will have to reload the firmware file.

1. Obtain the remote display firmware (.BIN) that you want to load onto your display. Save the files where they can be accessed by the computer running ION Setup.
2. Start ION Setup.
3. Open the Setup Assistant for your meter.
4. Select the Template screen.
5. Click the **Firmware Upgrade** tab, then click **Upgrade**. Enter your meter's password (if prompted) and click **OK**.
6. Navigate to where you have stored the remote display firmware. Select the remote display firmware file (\*.BIN) as the file type.
7. Select the remote display firmware (.BIN) file and click **Open**.
8. Enter your ION Setup password when prompted and click **OK**.

A dialog box describes the firmware upgrade progress, verifies the firmware, and finishes with an overview stating whether the firmware was successfully uploaded.

## Loading option module firmware using FTP

You can upload firmware to your meter's option modules by loading the firmware upgrade file onto your meter's internal FTP site.

You must have:

- Your meter's option module firmware upgrade (.SI9) file(s). You can download upgrade files from [www.usa.siemens.com/pds](http://www.usa.siemens.com/pds).
- The option module connected to your meter, and have access to your meter's internal FTP site.

Your meter's digital and analog outputs may change state during a firmware upgrade. Option modules are offline during an option module firmware upgrade; they will not communicate to the meter and the outputs may change state during the upgrade process.

<b>▲ WARNING</b>
<p><b>UNINTENDED OPERATION</b></p> <p><b>Failure to follow these instructions can result in death, serious injury, or equipment damage.</b></p> <p>Do not use this device for critical control or protection applications where human or equipment safety relies on the operation of the control circuit.</p>

**NOTE:** If your meter's option module loses power during firmware upload, the option module will revert to its original firmware and you will have to reload the firmware file.

1. Connect to your meter's internal FTP site. Open the option module upgrade (optionModuleUpg) folder.
2. Drag the option module firmware file into the option module upgrade folder. The file is immediately transferred to the option module, and is not stored on the meter.

3. Review the option module firmware upgrade details stored in the meter's event log to confirm that the upload was successful.

### Related Topics

- Event log overview
- Accessing your meter's FTP server

## Loading remote display firmware using FTP

You can upload firmware to your meter's remote display by loading the firmware upgrade file onto your meter's internal FTP site.

You must have:

- Your meter's remote display firmware upgrade (.BIN) file. You can download upgrade files from [www.usa.siemens.com/pds](http://www.usa.siemens.com/pds).
  - The remote display connected to your meter, and have access to your meter's internal FTP site.
1. Connect to your meter's internal FTP site.
  2. Open the remote display upgrade (rmdUpg) folder.
  3. Drag the remote display firmware file into the remote display upgrade folder. The file is immediately transferred to the remote display, and is not stored on the meter.
  4. Watch your meter's display to confirm the firmware upgrade is taking place.
  5. Review the remote display firmware upgrade details stored in the meter's event log to confirm that the upload was successful.

### Related Topics

- Event log overview
- Remote display troubleshooting icons
- Accessing your meter's FTP server

## Device-specific information

Manufacturing-related information about the meter is available from the Factory module or through Modbus commands.

The meter's Factory module stores meter details such as device type, serial number and vendor name. You can use ION Setup in advanced mode to view the contents of the Factory module's setup registers. Similarly, you can use Modbus commands to read the Modbus registers mapped to the corresponding Factory module's registers.

**NOTE:** Not all ION device setup registers are mapped to Modbus registers by default.

Other device-specific details, such as Product Code, are not stored in the Factory module. Product Code (also known as Modbus Product ID) is a number that the manufacturer assigned to a product to uniquely identify it, for use by systems that specifically require this information. You can use the device's Modbus map and Modbus commands to read the Modbus Product ID.

The *ION Reference* describes the Factory module in detail. You can download the *ION Reference* and your device's Modbus map from [www.usa.siemens.com/pds](http://www.usa.siemens.com/pds).

# Troubleshooting

## Technical assistance

Visit [www.usa.siemens.com/pds](http://www.usa.siemens.com/pds) for support and assistance technical problems with the meter.

Make sure you include your meter's model, serial number and firmware version in your email or have it readily available if calling Technical Support.

## Option module troubleshooting

Your meter's option modules operate sequentially; if one module is non-functional all downstream modules may be affected.

If your meter cannot communicate with an option module, by default it cycles power to that module and all downstream modules, making multiple attempts to communicate. After the maximum number of communication attempts has been exceeded the meter will remove power to that module and all downstream modules.

When troubleshooting option modules, attach each option module directly to the meter and verify its operation. If each option module operates when directly connected, use combinations of modules or known good modules to help identify the issue.

Events related to option module initialization and operation are stored in your meter's onboard event log. Perform an option bus reset to restart the option bus and re-initialize the option modules attached to your meter.

Information about your option module's type, serial number, firmware version and present status is available in the Factory and Diagnostics modules.

See the ION Reference, available from [www.usa.siemens.com/pds](http://www.usa.siemens.com/pds), for more information about the Factory and Diagnostics modules.

# Meter webpages

The meter's Ethernet connection allows you to access the meter so you can view data and perform trending and forecasting and some basic configuration using a web browser.

You can also view standard file types through the meter's webpages and create custom webpages for your meter.

## ⚠ WARNING

### INACCURATE DATA RESULTS

**Failure to follow these instructions can result in death, serious injury, or equipment damage.**

- Do not rely solely on data displayed on the display or in software to determine if this device is functioning correctly or complying with all applicable standards.
- Do not use data displayed on the display or in software as a substitute for proper workplace practices or equipment maintenance.

## Webpage interface

Your meter comes with default webpages that contain typical elements.

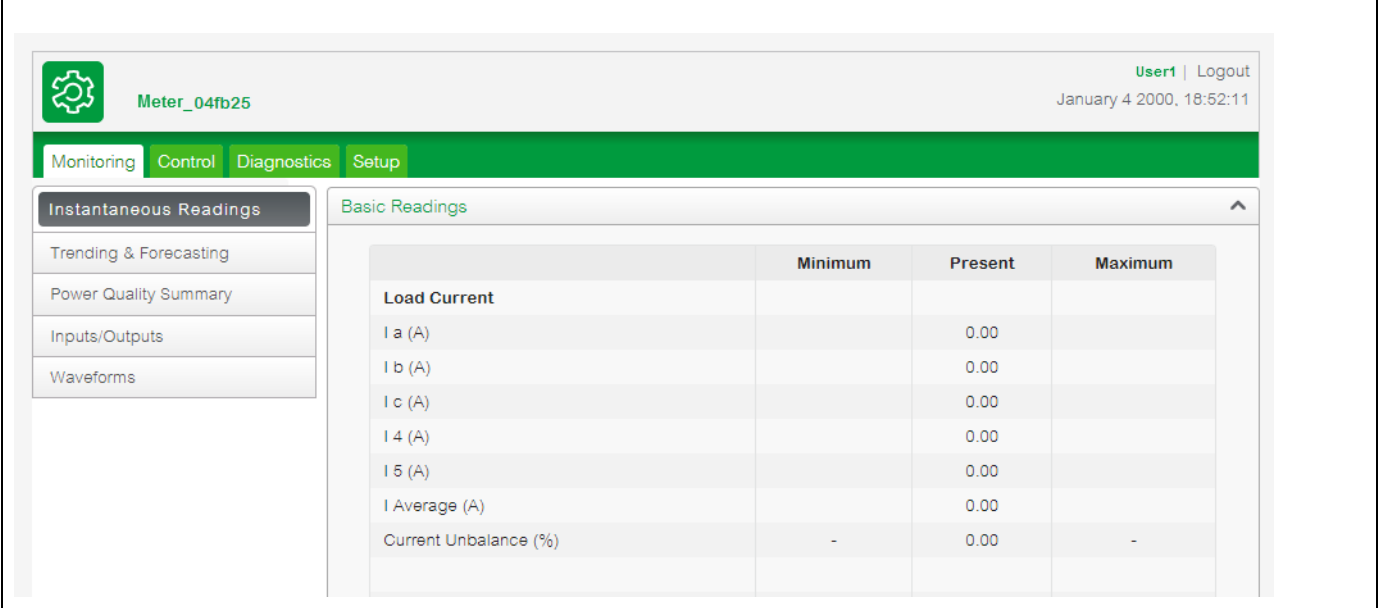

The screenshot shows the meter's web interface. At the top, there is a header with a gear icon, the meter name 'Meter\_04fb25', and user information 'User1 | Logout' with a timestamp 'January 4 2000, 18:52:11'. Below the header is a main menu with tabs for 'Monitoring', 'Control', 'Diagnostics', and 'Setup'. A sidebar menu on the left includes 'Instantaneous Readings', 'Trending & Forecasting', 'Power Quality Summary', 'Inputs/Outputs', and 'Waveforms'. The main content area displays 'Basic Readings' with a table of current measurements.

	Minimum	Present	Maximum
<b>Load Current</b>			
I a (A)		0.00	
I b (A)		0.00	
I c (A)		0.00	
I 4 (A)		0.00	
I 5 (A)		0.00	
I Average (A)		0.00	
Current Unbalance (%)	-	0.00	-

A	Meter type and model, device name
B	Username
C	Main menu
D	Webpage menu
E	Webpage content

**NOTE:** This graphic is representative only, and your meter's webpages may appear differently than shown.

## Default meter webpages

Default webpages are available on your meter.

### Monitoring

Webpage menu	Webpage content
Instantaneous Readings	<ul style="list-style-type: none"> <li>Basic readings</li> <li>Energy readings</li> <li>Demand readings</li> <li>Voltage readings</li> <li>Power Quality</li> </ul>
Trending & Forecasting	Select the target and interval for trending and forecasting and view the results.
Power Quality Summary	<ul style="list-style-type: none"> <li>Harmonics</li> <li>ITI (CBEMA)-SEMI</li> <li>NEMA Motor Derating Curve</li> <li>EN50160</li> </ul>
Inputs/Outputs	<ul style="list-style-type: none"> <li>Digital inputs</li> <li>Digital outputs</li> <li>Analog inputs</li> <li>Analog outputs</li> </ul>
Waveforms	View waveforms from your meter, using the meter's COMTRADE files

### Control

Webpage menu	Webpage content
Resets	Perform resets, and view when previous resets were performed.

### Diagnostics

Webpage menu	Webpage content
Statistics	<ul style="list-style-type: none"> <li>Communications</li> <li>Ethernet</li> <li>Serial port</li> <li>Meter - Basic</li> <li>Meter - Advanced</li> </ul>
Phasor diagram	View the phasor diagram and numeric values.

### Setup

Webpage menu	Webpage content
Ethernet	<ul style="list-style-type: none"> <li>Basic Settings</li> <li>Advanced settings</li> </ul>
Serial Port	<ul style="list-style-type: none"> <li>Basic Settings</li> <li>Advanced settings</li> </ul>
SNMP Parameters	Configure your meter's SNMP parameters.
NTP	Configure your meter's NTP parameters.
SMTP	Configure your meter's SMTP parameters.
Date & Time	Configure your meter's time and time synchronization.

Webpage menu	Webpage content
Preferences	Enter your meter's nameplate information.
Metering	Configure the parameters that impact metered data.

## Maintenance

Webpage menu	Webpage content
—	Custom. No default content. By default the Maintenance menu is empty, and the menu is not displayed until information is added to it.

## Accessing the meter's webpages for data viewing and meter configuration

You can access the meter's webpages through the meter's Ethernet connection using a web browser.

You must have cookies enabled in order to access your meter's webpages.

You must configure your meter's security settings in order to view webpages and configure your meter using webpages.

On a hardware-locked meter you cannot add, delete or modify any webpage files.

When configuring communications parameters, ensure you maintain at least one communication path that allows full access to your device; otherwise you may permanently lose the ability to change your device's configuration and access to additional data.

### **NOTICE**

#### **LOSS OF ACCESS**

**Failure to follow these instructions can result in loss of access to the device.**

Ensure you maintain sufficient access to communicate with and configure your device.

1. Open a web browser and enter your meter's IP address in the address box.

The webpage login prompt is displayed.

2. Enter a valid username and password.

**NOTE:** The username and password are defined by your meter's security configuration; if standard security is enabled, the password is the same as the display password with a default username of 9410. The default display password is 0 (zero). To help increase the security of your meter's configuration and data, configure your meter's username and passwords to be different from the default values.

3. Select your desired **Language** from the drop-down list, and click **Log In**.

Your meter's webpages are displayed. The default page is the **Monitoring** webpage, showing real-time data.

4. Select the main menu tab that corresponds to the category of information you want to view, and select the webpage menu from the list on the left.

The webpage content is displayed.

5. Click the webpage content headings to expand and view the meter's data.

6. Select **Setup** to view and edit your meter's configuration.

## Viewing files using your meter's webpages

You can load files of a variety of standard formats, such as \*.pdf, \*.jpg and \*.png into the webpage folders on your meter's internal FTP site where they can be viewed using your meter's webpages.

Videos in \*.mp4 format can be played in most browsers. The filenames must be compatible with your meter's FTP filename requirements.

**NOTE:** Image files are shown at full-size (100%). Scale images to the desired size before loading them onto your meter's internal FTP site.

1. Access your meter's internal FTP site.
2. Open the web folder. Copy your file into the subfolder that corresponds to the webpage main menu tab you want to access your file from.
3. Connect to your meter's webpages. Select the main menu item that corresponds to the folder where you stored your file in step 2. Your file is listed in the webpage menu.
4. Select your file from the webpage menu to view.

### Example

To view a schematic diagram (online.pdf) of your power system from the Monitoring menu of your meter's webpages:

1. Access your meter's internal FTP site.
2. Copy online.pdf into **web > monitoring**.
3. Access your meter's internal webpages and select the **Monitoring** menu.
4. In the webpage menu click online.pdf to view your power system schematic.

### Related Topics

- FTP
- FTP filename requirements

## Creating custom webpages for your meter

You can create custom webpages to view data or access configuration parameters from your meter.

Download the your meter's Modbus registers map from [www.usa.siemens.com/pds](http://www.usa.siemens.com/pds).

1. Connect to your meter's internal FTP site.
2. Go to **web > examples**. Select `samplerreadings.html` to create a data value webpage, or select `sampleconfiguration.html` to create a configuration parameters webpage.
3. Save a copy of the sample file. This filename is the webpage name.
4. Open your webpage in an HTML or webpage editor program.
5. Modify the webpage to reference the desired meter data or parameters from the Modbus registers map, and update the other fields where required.

6. Save your custom webpage.  
The meter will display translated content if it exists in the meter’s memory. If translated content is not available, English is displayed.
7. Connect to your meter’s internal FTP site.
  - If you have created a data viewing webpage, copy your custom webpage to **web > monitoring**.
  - If you have created a configuration webpage, copy your custom webpage to **web > setup**.
8. Login to your meter’s webpages.

Your custom webpage is available from the webpage menu under the monitoring (data viewing) or setup (configuration) tab.

### Related Topics

- FTP

## Sample data viewing webpage

You can create custom data viewing webpages using the sample webpage stored on your meter.

The sample webpages are stored in the documents folder on your meter’s internal FTP site.

Your meter’s Modbus register map is available from [www.usa.siemens.com/pds](http://www.usa.siemens.com/pds).

If required, your meter’s ION handles document is packaged with the meter firmware file which is available for download from [www.usa.siemens.com/pds](http://www.usa.siemens.com/pds).

The data viewing webpage must be stored on your meter’s internal FTP site in the folder for Monitoring. The custom webpage is viewed by selecting the Monitoring main menu tab on your meter’s webpage.

Configuring the HTML code other than where described is an advanced procedure and should only be performed by those with an advanced understanding of webpages and how your meter processes them.

### Sample webpage data viewing result

**NOTE:** This graphic is representative only, and your meter’s webpages may appear different than shown.

	Minimum	Present	Maximum
I a (A)	0.00	3.76	3.76
I b (A)	0.00	5.01	5.01

A	HTML filename
B	Content pane title
C	Row heading
D	Units
E	Column heading

F	Named register instantaneous value
G	Second content pane A title

## Sample HTML code for data viewing webpage content

Content and formatting of a data viewing webpage is controlled by its HTML code.

### Sample data viewing webpage content

Line #	Sample HTML
1	SampleMonitorPane.html
2	<div class="content-fit">
3	<div class="accordion">
4	<h3 target="sample-readings">\${%localizedString (Basic Readings) #\$/h3>
5	<div id="sample-readings">
6	<table class="datatable">
7	<tr>
8	<th>&nbsp;</th>
9	<th>\${%localizedString (Minimum) #\$/th>
10	<th>\${%localizedString (Present) #\$/th>
11	<th>\${%localizedString (Maximum) #\$/th>
12	</tr>
13	<tr class="minor">
14	<td>\${%localizedString (I a) # \$ <span unitsreg="I a"></span></td>
15	<td regname="I a mn"></td>
16	<td regname="I a"></td>
17	<td regname="I a mx"></td>
18	</tr>
19	<tr class="minor">
20	<td>\${%localizedString (I b) # \$ <span unitsreg="I b"></span></td>
21	<td regname="I b mn"></td>
22	<td regname="I b"></td>
23	<td regname="I b mx"></td>
24	</tr>
25	</table>
26	</div>
27	<h3 target="sample-energy">\${%localizedString (Energy Readings) #\$/h3>
28	<div id="sample-energy">
29	<table class="datatable">
30	<tr>
31	<th>&nbsp;</th>
32	<th>\${%localizedString (Present) #\$/th>
33	</tr>
34	<tr>

Line #	Sample HTML
35	<td>\${%localizedString (Active Energy) # \$ <span unitsreg="kWh del-rec"></span></td>
36	<td regname="kWh del-rec"></td>
37	</tr>
38	<tr>
39	<td>\${%localizedString (Reactive Energy) # \$ <span unitsreg="kVARh del-rec"></span></td>
40	<td regname="kVARh del-rec"></td>
41	</tr>
42	</table>
43	</div>
44	</div>
45	
46	
47	<script type="text/javascript">
48	
49	instantaneousReadings.initInstantaneousReadings ('sample-readings');
50	
51	</script>
52	</div>

### Sample webpage data viewing content description

Line #	Description
1	SampleMonitorPane.html The HTML filename, including the HTML extension (.html). This filename must comply with FTP filename conventions (no spaces or special characters). The filename (without the HTML extension) is the name shown on the webpage menu.
4	<h3 target="sample-readings"> This creates the first webpage content pane. "sample-readings" is the name of the webpage content. This name must be unique. \${%localizedString (Basic Readings) # \$</h3> Basic Readings is the title of the webpage content pane. This title is translated if possible.
5	<div id="sample-readings"> This must match the name of the webpage content in line 4.
9	<th>\${%localizedString (Minimum) # \$</th> Minimum is the heading for the first column. This heading is translated if possible.
10	<th>\${%localizedString (Present) # \$</th> Present is the heading for the second column. This heading is translated if possible.
11	<th>\${%localizedString (Maximum) # \$</th> Maximum is the heading for the last column. This heading is translated if possible.
14	<td>\${%localizedString (I a) # \$ I a is the row heading. This heading is translated if possible. <span unitsreg="I a"></span></td> This displays the units that the meter has defined for the named register I a.
15	<td regname="I a mn"></td> This displays the instantaneous value of the named register I a mn.
16	<td regname="I a"></td> This displays the instantaneous value of the named register I a.
17	<td regname="I a mx"></td> This displays the instantaneous value of the named register I a mx.
20	<td>\${%localizedString (I b) # \$ I b is the second row heading. This heading is translated if possible. <span unitsreg="I b"></span></td> This displays the units that the meter has defined for the named register I b.

Line #	Description
21	<code>&lt;td regname="I b mn"&gt;&lt;/td&gt;</code> This displays the instantaneous value of the named register I b mn.
22	<code>&lt;td regname="I b"&gt;&lt;/td&gt;</code> This displays the instantaneous value of the named register I b.
23	<code>&lt;td regname="I b mx"&gt;&lt;/td&gt;</code> This displays the instantaneous value of the named register I bmx.
27	<code>&lt;h3 target="sample-energy"&gt;</code> This creates the second webpage content pane. Sample-energy is the name of the webpage content. This name must be unique. <code>\$\$LocalizedString(Energy Readings) #&lt;/h3&gt;</code> Energy Readings is the title of the webpage content pane. This title is translated if possible.
28	<code>&lt;div id="sample-energy"&gt;</code> This must match the name of the webpage content in line 27.
32	<code>&lt;th&gt;\$\$LocalizedString(Present) #&lt;/th&gt;</code> Present is the heading for the last column. This heading is translated if possible.
35	<code>&lt;td&gt;\$\$LocalizedString(Active Energy) #&lt;/td&gt;</code> Active Energy is the row heading. This heading is translated if possible. <code>&lt;span unitsreg="kWh del-rec"&gt;&lt;/span&gt;&lt;/td&gt;</code> This displays the units that the meter has defined for the named register kWh del-rec.
36	<code>&lt;td regname="kWh del-rec"&gt;&lt;/td&gt;</code> This displays the instantaneous value of the named register kWh del-rec. <sup>1</sup>
39	<code>&lt;td&gt;\$\$LocalizedString(Reactive Energy) #&lt;/td&gt;</code> Reactive Energy is the row heading. This heading is translated if possible. <code>&lt;span unitsreg="kVARh del-rec"&gt;&lt;/span&gt;&lt;/td&gt;</code> This displays the units that the meter has defined for the named register kVARh del-rec.
40	<code>&lt;td regname="kVARh del-rec"&gt;&lt;/td&gt;</code> This displays the instantaneous value of the named register kVARh del-rec. <sup>1</sup>
49	<code>instantaneousReadings.initInstantaneousReadings('sample-readings');</code> Sample-readings is the unique name of the first webpage content name. This HTML code updates all of the webpage's values.

<sup>1</sup>Named registers are listed in the Modbus registers map. If the desired value is not listed, you can reference the value by its ION handle, using the following format: `<td regname="_0x####"></td>`, where #### is the hexadecimal value of the ION handle.

## Sample setup webpage

You can create custom setup webpages using the sample webpage stored on your meter.

Sample webpages are stored in the documents folder on your meter's internal FTP site.

Your meter's Modbus register map is available from Siemens Industry.

If required, your meter's ION handles document is packaged with the meter firmware file which is available for download from [www.usa.siemens.com/pds](http://www.usa.siemens.com/pds).

Custom setup webpages must be stored on your meter's internal FTP site in the folder for Setup. The custom webpage is viewed by selecting the Setup main menu tab on your meter's webpage.

Configuring the HTML code other than where described is an advanced procedure and should only be performed by those with an advanced understanding of webpages and how your meter processes them.

### Sample webpage setup result

**NOTE:** This graphic is representative only, and your meter's webpages may appear different than shown.

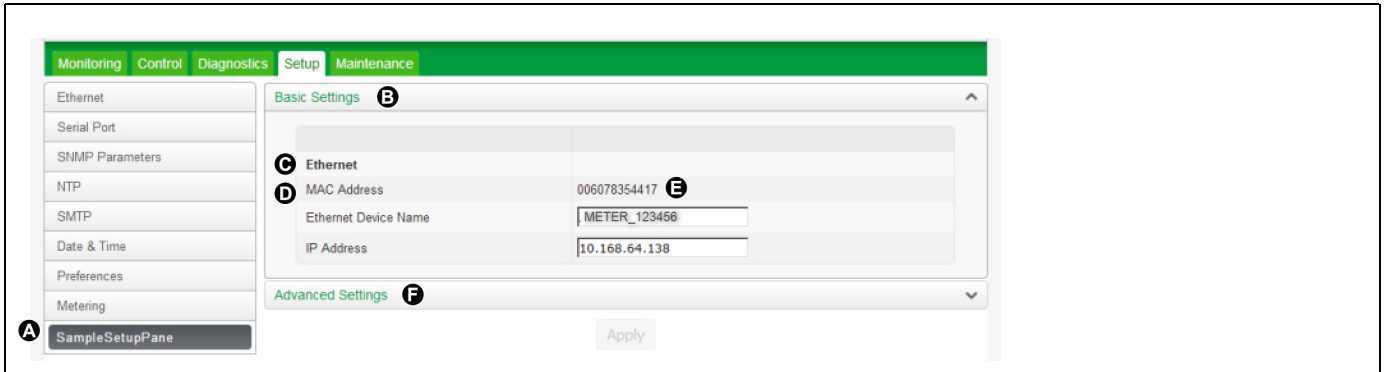

A	HTML filename
B	Content pane title
C	Sub-heading
D	Row heading
E	Named register value
F	Second content pane title

### Sample HTML code for setup webpage content

Content and formatting of a setup webpage is controlled by its HTML code.

#### Sample setup webpage content

Line #	Sample HTML
1	SampleSetupPane.html
2	
3	<div class="content-fit">
4	<form id="formSampleSettings">
5	
6	<div class="accordion">
7	<h3 target="sample-basic">\${localizedString(Basic Settings) #}\$</h3>
8	<div id="sample-basic">
9	<table class="formtable">
10	<tr>
11	<th>&nbsp;</th>
12	<th>&nbsp;</th>
13	</tr>
14	<tr>
15	<td>\${localizedString(Ethernet) #}\$</td>
16	<td>&nbsp;</td>
17	</tr>
18	<tr class="minor">
19	<td>\${localizedString(MAC Address) #}\$</td>
20	<td regname="MAC Address"></td>
21	</tr>
22	<tr class="minor">

Line #	Sample HTML
23	<td>\${%localizedString(Ethernet Device Name) #}\$</td>
24	<td><input name="Ethernet Device Name" type="text" /></td>
25	</tr>
26	<tr class="minor">
27	<td>\${%localizedString(IP Address) #}\$</td>
28	<td><input name="IP Address" type="text" /></td>
29	</tr>
30	</table>
31	
32	</div>
33	
34	<h3 target="sample-advanced">\${%localizedString(Advanced Settings) #}\$</h3>
35	<div id="sample-advanced">
36	<table class="formtable" id="frameFormatDropdownContainer">
37	<tr>
38	<th>&nbsp;</th>
39	<th>&nbsp;</th>
40	</tr>
41	<tr>
42	<td>\${%localizedString(TCP Keep Alive Minutes) #}\$</td>
43	<td><input type="text" name="TCP Keep Alive Minutes" class="small" /> <span unitsreg="TCP Keep Alive Minutes"></span></td>
44	</tr>
45	<tr>
46	<td>\${%localizedString(Enable Web Server) #}\$</td>
47	<td><select name="Enable Web Server"></select> </td>
48	</tr>
49	</table>
50	
51	</div>
52	</div>
53	
54	<input type="submit" class="apply" value='\${%localizedString(Apply) #}\$' />
55	
56	</form>
57	
58	
59	<script type="text/javascript">
60	
61	SetupPane.init('formSampleSettings');
62	formChangeDetection.initFormChangeDetection('#formSampleSettings', '#dialogFormChanges');
63	

Line #	Sample HTML
64	</script>
65	</div>

### Sample setup webpage content description

Line #	Description
1	SampleSetupPane.html The HTML filename, including the HTML extension (.html). This filename must comply with FTP filename conventions (no spaces or special characters). The filename (without the HTML extension) is the name shown on the webpage menu.
4	<form id="formSampleSettings"> "formSampleSettings" is the name of the webpage content. This name must be unique
7	<h3 target="sample-basic"> This creates the first webpage content pane. "sample-basic" is the name of the webpage content. This name must be unique. \${localizedString(Basic Settings) #}\$</h3> Basic Settings is the title of the webpage content pane. This title is translated if possible.
8	<div id="sample-basic"> This must match the name of the webpage content in line 7.
15	<td>\${localizedString(Ethernet) #}\$</td> Ethernet is the subheading. This heading is translated if possible.
19	<td>\${localizedString(MAC Address) #}\$</td> MAC Address is the row heading. This heading is translated if possible.
20	<td regname="MAC Address"></td> This displays the value of the read-only named register MAC Address.
23	<td>\${localizedString(Ethernet Device Name) #}\$</td> Ethernet Device Name is the row heading. This heading is translated if possible.
24	<td><input name="Ethernet Device Name" type="text" /></td> This displays the instantaneous value of the configurable named register Ethernet Device Name in a text-edit field. The type must match the named register type, in this case, an alphanumeric string.
27	<td>\${localizedString(IP Address) #}\$</td> IP Address is the row heading. This heading is translated if possible.
28	<td><input name="IP Address" type="text" /></td> This displays the instantaneous value of the configurable named register IP Address in a text-edit field. The type must match the named register type, in this case, an alphanumeric string.
34	<h3 target="sample-advanced"> This creates the second webpage content pane. Sample-advanced is the name of the webpage content. This name must be unique. \${localizedString(Advanced Settings) #}\$</h3> Advanced Settings is the title of the webpage content pane. This title is translated if possible.
35	<div id="sample-advanced"> This must match the name of the webpage content in line 34.
42	<td>\${localizedString(TCP Keep Alive Minutes) #}\$</td> TCP Keep Alive Minutes is the row heading. This heading is translated if possible.
43	<td><input type="text" name="TCP Keep Alive Minutes" class="small" /> This displays the instantaneous value of the configurable named register TCP Keep Alive Minutes in a text-edit field. The type must match the named register type, in this case, an alphanumeric string. <span unitsreg="TCP Keep Alive Minutes"></span></td> This displays the units that the meter has defined for the named register TCP Keep Alive Minutes. NOTE: There are no defined units for TCP Keep Alive Minutes, so no units are displayed.
46	<td>\${localizedString(Enable Web Server) #}\$</td>

Line #	Description
	Enable Web Server is the row heading. This heading is translated if possible.
47	<pre data-bbox="277 226 906 254">&lt;td&gt;&lt;select name="Enable Web Server"&gt;&lt;/select&gt; &lt;/td&gt;</pre> Enable Web Server is the named register that is displayed. Named registers are listed in the meter's registers map. The type must match the named register type, in this case, an enumerated value that is displayed as a drop-down list.
61	<pre data-bbox="277 338 743 365">SetupPane.init('formSampleSettings');</pre> This must match the webpage content name from line 4.
62	<pre data-bbox="277 417 1398 445">formChangeDetection.initFormChangeDetection('#formSampleSettings', '#dialogFormChanges');</pre> This must match the webpage content name from line 4. This HTML code updates all of the webpage's values.

# Logging

## Logging overview

The meter is equipped with data recorders, waveform recorders and event logs that enable you to log and monitor various metering functions and features.

Your meter has a number of onboard default logs (also called data recorders) that are used to store data related to:

- Power quality and compliance
- Trending and forecasting
- Energy/revenue metering
- Meter events

Your meter also logs voltage and current waveform data when a sag or swell is detected. You must enter your power system's nominal values and configure your meter so that it can identify sags and swells; and you can enable current waveform recording if it is required for your system. You can configure your meter's setpoint learning feature to learn your power system's normal operating values and use that information to help identify voltage sags and swells.

Logged data can be retrieved by energy management software.

### Related Topics

- Minimum configuration requirements for basic metering

## Data logging overview

Your meter has data logging capabilities, including a special type of data log which is an event log, which logs prioritized events.

Data logs are recorded by your meter and stored in the meter's memory inside configurable data logs. Your meter's data logs are retained if the meter loses power.

Logged data can be used by energy management software. Logs can be configured to either overwrite the oldest data when full (circular), or to stop writing data to the log when the number of logged records reaches the maximum log depth (stop-when-full).

Your meter ships with a comprehensive data-logging configuration consisting of data logs set up to record values at specific intervals or on conditions. Your meter's default data logging configuration should be sufficient for most applications, but you can also reconfigure existing logs or create new logs for custom applications if needed.

Your meter can also be configured to email data log information.

**NOTE:** Adding or deleting data logs or their parameters outside of the ION Setup Assistant should only be undertaken by those with an advanced understanding of ION architecture and their meter's template.

See the *Internal email client feature* technical note, available from [www.usa.siemens.com/pds](http://www.usa.siemens.com/pds), for instructions on how to configure your meter to email logged data.

See the *ION Reference*, available from [www.usa.siemens.com/pds](http://www.usa.siemens.com/pds), for more information about ION architecture and ION modules.

## Event log overview

Your meter records events produced by the meter's ION modules or external meter events.

Meter events, such as meter configuration or changes to I/O state, have priority values associated with them, so you can control what events are logged. Each event has a priority based on its type and severity, and for most events you can configure the priority. The event log records the date and time of the event, along with relevant details about the event.

Your meter's event log can be viewed through the meter's display and ION Setup.

Event log data example:

Date/Time	Cause	Value	Effect	Value
11/10/2014 11:21:13.577 AM	Ethernet	FTP	Front Panel	Auth FAIL
11/10/2014 11:21:43.000 AM	Front Panel	Remote Display	Front Panel	File received on RMD
11/10/2014 11:24:45.000 AM	Front Panel	Remote Display	Front Panel	RMD firmware upgrade successful
11/10/2014 11:24:48.135 AM	Front Panel	Remote Display	Front Panel	RMD disconnected
11/10/2014 11:25:15.820 AM	Front Panel	Remote Display	Front Panel	RMD connected
11/10/2014 11:29:27.316 AM	Ethernet	FTP	Front Panel	Auth FAIL

**NOTE:** This example is representative only, and your meter's event log may appear different than shown.

See the ION Reference, available from [www.usa.siemens.com/pds](http://www.usa.siemens.com/pds), for more information about the Event Log Controller module and other ION modules.

### Related Topics

- Event logging
- Data viewing using your meter's display

### User triggered event log entries

The Event Log includes an association between security-related events and the username that was logged in to the meter during the event.

When a user produces an event, such as a reset, successful or unsuccessful login attempts, user lockout or setup change, it is written to the event log. Events created in standard security through the meter's display have the username USER0. Events created in advanced security through the display or ION Setup are associated with the username that was logged into the meter (USER1 - USER50).

Date/Time	Cause	Value	Effect	Value	User
10/17/2016 4:07:46.022 PM	Ethernet	Changed Setup	SOP1 Enable Advanced Security	Value Changed	USER0
10/18/2016 9:26:26.044 AM	Ethernet	HTTP	Front Panel	Auth FAIL	USER0
10/20/2016 11:06:07.503 AM	Ethernet	Changed Setup	ETH1 Enable Telnet	No	USER1
10/20/2016 11:06:07.520 AM	Ethernet	Changed Setup	ETH1 Telnet Port Number	23	USER1
10/20/2016 11:06:24.042 AM	Ethernet	Changed Setup	ETH1 Enable Telnet	Yes	USER1
10/20/2016 11:06:24.054 AM	Ethernet	Changed Setup	ETH1 Telnet Port Number	23	USER1

### Assigning a designated reader for event log notification

A user can be assigned the role of designated reader for the event log.

When the *Designated Reader* is configured, an entry in the event log is considered unread until it has been reviewed or backed up to external storage by the designated reader. When the designated reader is informed that the event log is nearly full, an event log review or backup strategy can be implemented before older entries are overwritten. This feature can assist in ensuring that event log entries are not overwritten before they can be reviewed. Use ION Setup to select a user to be the designated reader.

1. Open advanced configuration mode for your meter. See the ION Setup Help for instructions.
2. Open the EventLogCtl Modules folder and double click **EventLogCtl**.
3. Enter login credentials as necessary.
4. Click the **Setup Registers** tab
5. Select *Designated Reader* and click **Edit**.
6. Set *Designated Reader* to the user that reviews the event log (USER0 - USER50) and click **OK**.

## Syslog overview

Syslog uses the User Datagram Protocol (UDP) to transport event log information from the meter directly to a centralized syslog server.

The syslog server can receive logs from multiple devices, including meters, then store and filter the log information as needed. You can use ION Setup to modify the syslog network settings for your device. Syslog is a useful feature to help maintain meter log information for extended periods of time.

**NOTE:** Ethernet is required to use the syslog feature.

Syslog is an open standard allowing you to use any one of a number of syslog server applications currently available. The decision regarding which syslog server solution to use can be based on budget and your technical requirements. See the individual syslog server's documentation for more information.

### Configuring Syslog network settings using ION Setup

You can configure your syslog settings using ION Setup.

1. Open the Setup Assistant for your meter. See the ION Setup Help for instructions.
2. Select **Communications > Advanced Ethernet** and click the **SysLog** tab.
3. Select **Enable Syslog** and click **Edit**.
4. Select **Yes** to enable the syslog server feature or select **No** to disable it.
5. Click **OK**.
6. Select **Syslog Server** and click **Edit**.
7. Enter the IPv4 address or an IPv6 address for the syslog server.

You must enter the IP address for the syslog server, not the server's fully-qualified domain name.

8. Click **OK**.
9. Verify that the Syslog server is receiving log information from the meter.

**NOTE:** If the *Enable Syslog* register is enabled but the *Syslog Server* register does not contain an IP address, an event is generated in the event log to indicate that syslog is enabled with no server IP.

### Syslog severity to event log priority mapping

Syslog severities map to ION event priorities (0-255).

Only four of the syslog severities are used in the mapping.

Syslog severity	ION event priority name	ION event priority range
2 - Critical condition	High	192-255
4 - Warning condition	Medium	128-191
5 - Normal but significant condition	Low	64-127
6 - Informational	None	0-63

## Waveform recording overview

Your meter is able to record voltage and current waveform information.

Waveform information is used to help identify power system disturbances, which are an increasing concern for industrial plants, hospitals, data centers and other facilities where the equipment is sensitive to voltage or current sags, swells, and momentary interruptions. Waveform information is also used to help ensure compliance with power quality standards.

In addition to measuring and recording numerical values for voltage and current, your meter can also capture the sinusoidal waveform data. The current and voltage waveform data provides additional information for analysis of the system's power quality or a power quality event.

You can manually trigger waveform recordings or configure them to trigger automatically when there is a power quality or power system event. For waveform recording to trigger automatically, you must enter your system's nominal (normal) voltage and current values, and then the amount of deviation from the nominal required to trigger waveform recording.

## Waveform data storage format

Your meter's waveform data storage format is defined by:

- Cycles: the number of cycles (based on your power system's frequency) included in the waveform (its duration).
- Samples: samples per cycle, which is the number of waveform data points collected in each cycle.

This gives you the option to record a lot of information for a very short duration or less information over a longer duration. You can also configure a delay in starting waveform recording which allows you to record pre- and post-event data.

## Types of waveform data

You can use your meter to detect ITI (CBEMA) - type disturbances, and can determine information regarding the magnitude and duration of each disturbance. This information can be used by your energy management system to plot the disturbance on a CBEMA curve.

COMTRADE waveform data is available from your meter.

**NOTE:** If you are generating COMTRADE waveform information, the associated waveform recorders cannot be modified unless COMTRADE is disabled. If the waveform recorders are not configured identically, COMTRADE waveform information will not be generated.

## Key terms

Term	Definition
COMTRADE	COMMon format for TRAnsient Data Exchange (COMTRADE) is a common format for waveform data.
ITI (CBEMA)	A curve that graphically describes an AC input voltage envelope which can be typically tolerated by information technology equipment. Meter waveform information is plotted on this curve to help evaluate power quality.
Nominal	The normal or usual parameter value. For example, the nominal voltage for many power systems is 120 V.
Sag	A power event where the voltage or current drops below the nominal value.
Swell	A power event where the voltage or current rises above the nominal value.

See the ION Reference, available from [www.usa.siemens.com/pds](http://www.usa.siemens.com/pds), for more information on the Waveform Recorder module and its settings.

### Related Topics

- Setpoint learning overview
- COMTRADE
- Minimum configuration requirements for basic metering

## Configuring sag/swell logging and waveform recording using ION Setup

You can configure your meter to record sag/swell data and to capture waveforms when it experiences a sag or swell event, and to export the waveform data to COMTRADE files.

**NOTE:** For waveform recording to trigger automatically, enter your system's nominal (normal) voltage and current values and the amount of deviation from the nominal that is considered a sag or a swell using the **Alarming** screen.

Changing your meter's waveform recording configuration clears your meter's existing waveform records, including its COMTRADE files.

### **NOTICE**

#### **DATA LOSS**

**Failure to follow these instructions can result in data loss.**

Ensure that all important data has been recorded before configuring waveform recording.

1. Start ION Setup.
2. Open the Setup Assistant for your meter.
3. Navigate to **Power Quality** and click the **Sag/Swell Logging** tab.
4. Select the data log and click **Edit** to configure your meter's sag/swell logging and waveform recording parameters.  
The **Sag/Swell Log Setup wizard** appears.
5. Set the **Log Depth** on the **Data Logging Setup** screen to specify the number of records the sag/swell data log can hold.

6. Configure the waveform recording settings on the **Waveform Log Setup** screen:
  - a. Set the **Waveform Depth** to specify the maximum number of waveform records stored on the meter.
  - b. Set the **Waveform Format** to specify the number of samples per cycle and the number of cycles that are stored in a waveform record.
  - c. Set the **Trigger Position** to specify the number of cycles to capture before the waveform versus after the waveform, using the pre-cycle arrows or the slider

**NOTE:** The maximum number of cycles (pre-event + post-event) cannot exceed the total number of cycles in the waveform format.

7. Configure your meter's COMTRADE settings:
  - a. Select or clear the **Generate COMTRADE files** checkbox to enable or disable the creation of COMTRADE records.
 

**NOTE:** The waveform viewer on your meter's webpages uses the meter's COMTRADE files. If you want to view waveforms on the meter's webpages, make sure you select **Generate COMTRADE files**.
  - b. Set the **Log depth** for the COMTRADE files to specify the number of records stored on your meter's FTP site.

8. Click **Finish**.

You are returned to the Sag/Swell screen and the entry shows your new configuration.

If nothing happens when you click **Finish**, check the log depths and buffer depths for all your other data logs to make sure that the meter has enough memory for these changes. Adjust the log depth and buffer depth of the data and waveform recorders if needed.

## Related Topics

- COMTRADE implementation overview
- Configuring sag/swell alarms using ION Setup
- Changing log interval and depth settings using ION Setup

## Default logging framework

Your meter comes with a default logging framework, configured to record data and events at pre-defined intervals or conditions, that should be sufficient for most applications.

Data recorder number	Log name	Depth	Interval
1	Revenue Log	3360 (35 days)	900 seconds (15 minutes)
9	Loss Log	3360 (35 days)	900 seconds (15 minutes)
2, 3, 4	Historic Logs	3360 (35 days)	900 seconds (15 minutes)
39	Daily Nominal Log	450	Triggered on demand
7, 8	Harmonics Logs	840 (35 days)	3600 seconds (1 hour)
N/A	Waveform recorders (6 total)	30	Triggered on demand
N/A	COMTRADE records	10	Triggered by waveform recording (if COMTRADE logging is enabled)

Data recorder number	Log name	Depth	Interval
10	Energy/Demand (EgyDmd Log)	3360 (35 days)	900 seconds (15 minutes)
5	Sag/Swell Log	100	Triggered on demand
N/A	Event Log	500	Triggered on demand
11, 12, 17, 19 - 26, 28, 29, 32, 35	EN50160 Logs	varies	EN50160 intervals
6, 16, 37, 38, 40	4-30 Logs	varies	IEC61000-4-30 intervals

Your meter can support up to 50 data logs (data recorders) which can each record up to 16 different parameters.

## Default data logging configuration

Your meter is equipped with preconfigured data logs which you can modify.

The default data logging configuration might be used by other components of your power monitoring system. Do not change the default configuration of any of the logs, unless you understand the impact of the change on these power monitoring system components and the data they use and on your meter's memory.

### Revenue log

The Revenue Log is configured for use with UTS MV-90 billing software. The default values logged by the Revenue Log are as follows:

Parameter	Description
kWh del int	Interval kWh delivered
kWh rec int	Interval kWh received
kVARh del int	Interval kVARh delivered
kVARh rec int	Interval kVARh received

### Historic data logs

Three historic data logs are used to record standard power system quantities, such as phase current, phase voltage and power factor. These logs are labeled Hist Mean Log, Hist High Log, and Hist Low Log. By default, they log the following values:

Hist Mean Log	
Vll ab mean	I avg mean
Vll bc mean	I 4 mean
Vll ca mean	kW tot mean
Vll avg mean	kVAR tot mean
V unbal mean	kVA tot mean
Ia mean	PF lag mean
Ib mean	PF lead mean
Ic mean	Freq mean

Hist High Log	
Vll ab high	I avg high
Vll bc high	I 4 high

Hist High Log	
Vll ca high	kW tot high
Vll avg high	kVAR tot high
V unbal high	kVA tot high
Ia high	PF lag high
Ib high	PF lead high
Ic high	Freq high

Hist Low Log	
Vll ab low	I avg low
Vll bc low	I 4 low
Vll ca low	kW tot low
Vll avg low	kVAR tot low
V unbal low	kVA tot low
Ia low	PF lag low
Ib low	PF lead low
Ic low	Freq low

### Loss log

The Loss Log is configured to record loss values. By default, it logs the following values:

Parameter	Description
MU Ia <sup>2</sup> h int	Phase A interval current squared hours
MU Ib <sup>2</sup> h int	Phase B interval current squared hours
MU Ic <sup>2</sup> h int	Phase C interval current squared hours
MU Vllab <sup>2</sup> h int	Phase A interval voltage Line-to-Line squared hours
MU Vllbc <sup>2</sup> h int	Phase B interval voltage Line-to-Line squared hours
MU Vllca <sup>2</sup> h int	Phase C interval voltage Line-to-Line squared hours
MU Vln a <sup>2</sup> h int	Phase A interval voltage Line-to-Neutral squared hours
MU Vln b <sup>2</sup> h int	Phase B interval voltage Line-to-Neutral squared hours
MU Vln c <sup>2</sup> h int	Phase C interval voltage Line-to-Neutral squared hours

### Harmonics logs

Two harmonics logs record various harmonics data, including K-factor and Total Harmonic Distortion (THD). These recorders are labeled Harm Mean Log and Harm High Log. By default, they log the following values:

Harm Mean Log	
V1 THD mean	I1 K Fac mean
V2 THD mean	I2 K Fac mean
V3 THD mean	I3 K Fac mean
I1 THD mean	

Harm Mean Log	
I2 THD mean	
I3 THD mean	

Harm High Log	
V1 THD high	I1 K Fac high
V2 THD high	I2 K Fac high
V3 THD high	I3 K Fac high
I1 THD high	
I2 THD high	
I3 THD high	

### Energy/Demand log

The Energy/Demand log records energy and demand data used by energy management software to generate reports. Changing the logged data can prevent the generation of reports that use this data.

### Sag/swell log

The Sag/swell Log provides details of power quality events. By default, it logs the following values:

SS1 DistDur	SS1 DistV1Min	SS1 DistV1Max	SS1 DistV1Avg
SS1 DistV1Engy	SS1 DistV2Min	SS1 DistV2Max	SS1 DistV2Avg
SS1 DistV2Engy	SS1 DistV3Min	SS1 DistV3Max	SS1 DistV3Avg
SS1 DistV3Engy	SS1 DistNominal	SS1 Swell Lim	SS1 Sag Lim

### EN50160 compliance logs

The EN50160 compliance logs are used to record EN50160 compliance parameters:

Data recorder	EN50160 component logged
EN50160 Frq/Mg	Power frequency and supply magnitude
EN50160 Hrm Vlt	Harmonics
EN50160 Intrp	Short/log interruptions
EN50160 Ovrvt1	Temporary overvoltage
EN50160 Ovrvt2	Temporary overvoltage
EN50160 Prm-f/V	Parameter data (disabled by default)
EN50160 Prm-Vlr	Parameter data (disabled by default)
EN50160 Vunbal	Voltage unbalance
EN50160 PrmHrm1	Parameter data (disabled by default)
EN50160 PrmHrm2	Parameter data (disabled by default)
EN50160 Vlt Dp1	Supply voltage dips
EN50160 Vlt Dp2	Supply voltage dips
EN50160 Vlt Dp3	Supply voltage dips

Data recorder	EN50160 component logged
EN50160 Vlt Dp4	Supply voltage dips
EN50160 Vlt Dp5	Supply voltage dips

The meter logs EN50160 counter data for present and previous observation periods as well as EN51060 events.

See the *EN50160 2010 compliance and ION meters* technical note, available from [www.usa.siemens.com/pds](http://www.usa.siemens.com/pds), for more information about your meter's EN50160 compliance.

#### 4-30 compliance logs

The 4-30 compliance logs are used to log parameters related to the International Electrotechnical Commission's IEC 61000-4-30 standards' power quality compliance and to create reports.

Data recorders: 4-30 10m log, 4-30 2hr log and 4-30 3s log		
PqFlag	V1 THD (Total Harmonic Distortion)	NegSeqComp (Vneg/Vpos)
V1	V2 THD	ZeroSeqComp (Vzero/Vpos)
V2	V3 THD	Power Freq 10m and 2hr logs only)
V3		

Data recorder: 4-30 10s Freq	
Power Frequency	PqFlag

Data recorder: 4-30 Intrp
Voltage interruption duration (all voltages)

See the *4-30 Compliance and ION Meters* technical note, available from [www.usa.siemens.com/pds](http://www.usa.siemens.com/pds), for more information about your meter's 4-30 compliance.

## Default event log configuration

Your meter logs all configuration changes, meter access events, and power system events.

You can configure certain features, such as the digital inputs, so an event is logged when the feature changes state (for example, the digital input changes from off to on).

Your meter's event log might be used by other components of your power monitoring system. Do not change the default event log configuration unless you understand the impact of the change on the power monitoring system components and the data they use and on your meter's memory.

Changing the default event log configuration should only be undertaken by those with an advanced understanding of ION architecture and their meter's template.

The event log is controlled by the Event Log Controller module, which allows you to set a priority cutoff for event logging. Events with a priority number greater than the cutoff value are logged, and events with lower priorities are discarded. By default, this value is set so that all relevant events are recorded in the meter's event log. Event priority values range from 0 to 255 with a typical cutoff value of 5.

**NOTE:** Alarms are generated by events from certain ION modules. The alarm level is determined by the priority of the associated event. To disable the alarm but still

record the associated event, set the alarm priority to **Info Only**. To disable the alarm and the event, set the alarm priority to **None**.

See the ION Reference, available from [www.usa.siemens.com/pds](http://www.usa.siemens.com/pds), for more information about the Event Log Controller module and event priorities for specific ION modules.

## Related Topics

- Alarms overview

## Default waveform recording configuration

Your meter's waveform recording operates once your nominal values are configured.

Your meter has the following default waveform recorders:

Waveform recorder	Description
Wfm Rc V1-Sg/Sw	V1 voltage waveforms recorded during a defined sag or swell event.
Wfm Rc V2-Sg/Sw	V2 voltage waveforms recorded during a defined sag or swell event.
Wfm Rc V3-Sg/Sw	V3 voltage waveforms recorded during a defined sag or swell event.
Wfm Rc I1-Sg/Sw	I1 current waveforms recorded during a defined sag or swell event.
Wfm Rc I2-Sg/Sw	I2 current waveforms recorded during a defined sag or swell event.
Wfm Rc I3-Sg/Sw	I3 current waveforms recorded during a defined sag or swell event.

## Advanced log setup and memory optimization

You can configure your meter's logs to help ensure the integrity of critical data and to optimize the meter's memory usage.

Before you configure your meter's logs, it is important to understand how logging functions and how the settings work together.

**NOTE:** Configuring your meter's logs requires an in-depth understanding of the meter's memory, how the logs function and the data you are capturing.

## Viewing log configuration and memory usage information

You can use ION Setup to view log settings and memory usage information for your meter's default logs.

This information can help you understand your log usage and how to optimize your logging configuration for your situation.

1. Start ION Setup.
2. Open the Setup Assistant for your meter.
3. Navigate to the **Logging > Memory** screen.

The **Status** tab:

- lists the default logs, their interval (**Duration**) and depth (**Records**), if applicable, and the percentage of available memory used by the log.
- provides information on how much of the meter's memory is used for system tasks in the System Resources list item.
- displays the total meter memory and the percentage of memory in use versus memory available.

## Log depth configuration

You can change the number of records (depth) stored in the log.

Use ION Setup to change the maximum number of records (depth) stored in the log in the meter's long-term memory.

Data logs and circular-format waveform recorders have a minimum depth of 2 records. The maximum depth is dependent on your meter's memory and the configuration of your other logs.

## Log interval configuration

You can configure the logging interval, which is how frequently records are logged.

For example, a 15-minute interval results in records being logged at 1:00, 1:15, 1:30, 1:45, and so on

You can change the logging intervals for most logs using the ION Setup Assistant **Logging > Memory** screen.

Changing the interval for other logs (for example, logs that are related to standards or triggered by disturbances) is an advanced procedure that involves using the Advanced mode of ION Setup to modify settings in the module that is linked to the log's *Record* input. See the ION Setup help and the *ION Reference* for more information.

Programming your meter to write to any data recorder at continuous intervals shorter than 60 seconds (heavy logging configuration) can cause loss of data in the event of a power failure.

### NOTICE

#### DATA LOSS

**Failure to follow these instructions can result in data loss.**

Use an uninterruptible power supply (UPS) if you program your meter for heavy logging.

## Log mode configuration

You can configure the log record mode, or how the log behaves when full.

Changing how the log records information (circular or stop-when-full) is an advanced procedure that requires changing the *RecordMode* setup register in the Data Recorder and Waveform Recorder modules.

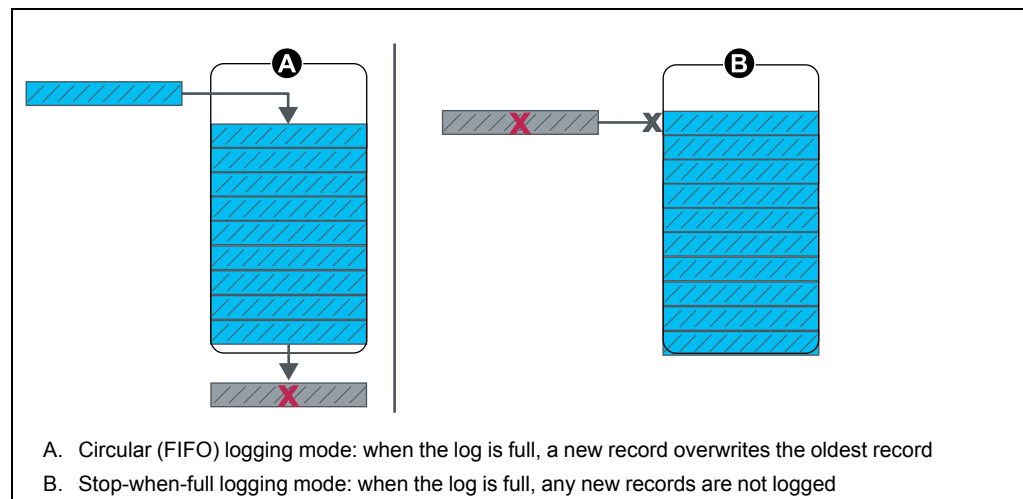

## Log buffer configuration

The log buffer depth is the maximum number of records that can be stored in the meter's short-term memory (RAM) for a particular log.

After records are captured in the log buffer in the meter's short-term memory, they are replicated to the long-term memory. Because of inherent differences between short-term (volatile) and long-term (non-volatile) memory, records can be added more quickly to the short-term memory than they can be copied to long-term memory.

The logs in the default logging framework have their log buffer depths pre-configured to a value suitable for most applications. But you can configure the log buffer depth for your applications, if required (for example, to help ensure the continuity of critical data in high-speed logging scenarios or to optimize usage of your meter's memory for your particular logging configuration).

If you are logging data at high speeds, it is important to review your logging needs, and find the right balance between data retention and memory optimization for your particular situation.

**NOTE:** If you get a message that you do not have sufficient memory when you try to create a new log or change the configuration of an existing log, you may need to reduce the log buffer depths of other logs in order to make memory available for the new log.

### Fully buffered logs

A fully buffered log (e.g., a Data Recorder or Waveform Recorder module) is one where the value of the Buffer Depth setup register is the same as the Depth setup register. This means the buffer (short-term memory) is set up to use all the available long-term memory allocated for that log. This ensures the buffer does not run out of space before all the records are replicated to the long-term memory, regardless of the recording speed (i.e., the rate of record captures).

You may want to use this configuration if you are logging critical data (for example, revenue logs) or logging data at frequent intervals (for example, intervals less than 60 seconds). However, it is important to note that this configuration uses the most short-term memory, or RAM (the meter has a maximum 10 MB of RAM available for the log buffer depth).

### Partially buffered logs

A partially buffered log (e.g., for a Data Recorder or Waveform Recorder module) is one where the value of the Buffer Depth setup register is less than the Depth setup register. This means the buffer (short-term memory) is set up to use only a portion of the available long-term memory allocated for that log. This configuration allows for a much larger log size (i.e., number of records). However this does not ensure that the buffer does not run out before all the records are replicated to the long-term memory (e.g., in the case of high-speed recording).

You may want to use this configuration for logs with intervals greater than 60 seconds or with less critical data. Because the records are partially replicated, this configuration uses less of the meter's short-term memory, or RAM, in a log that is otherwise configured the same. This allows you to make more RAM available for other logs with a higher logging frequency or more critical data.

However, depending on your configuration, there may be instances where the log buffer fills up faster than it can replicate records to long-term memory. In this case, you may lose records and see gaps in your data.

**NOTE:** The *Insert Outage Records* functionality does not work if the data recorder is configured as partially buffered. In order to use this functionality, you must configure the data recorder to be fully buffered. See the Data Recorder module description in the *ION Reference*, available for download from [www.usa.siemens.com/pds](http://www.usa.siemens.com/pds), for more information on *Insert Outage Records* functionality.

### Example: fully buffered log records replicated from short-term to long-term memory

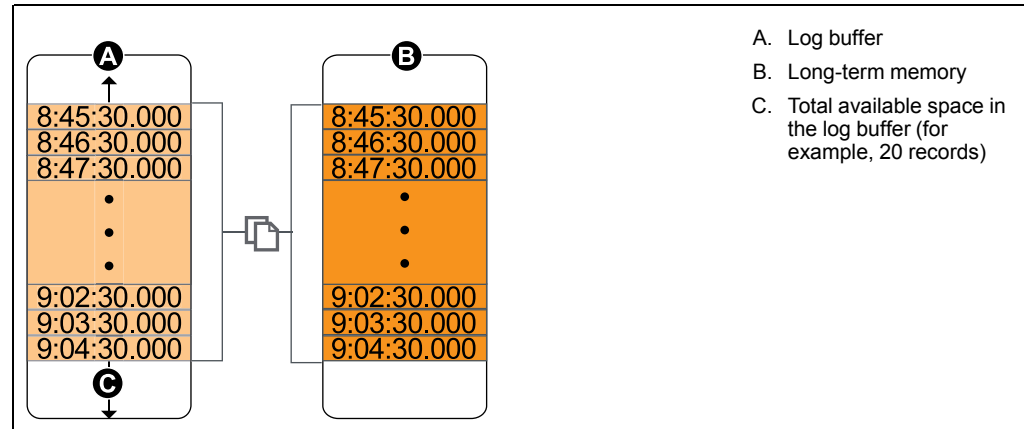

In this example, the log buffer equals the log depth and all the records are replicated in both the short-term memory and the long-term memory.

### Example: Partially buffered log records replicated from short-term memory to long-term memory

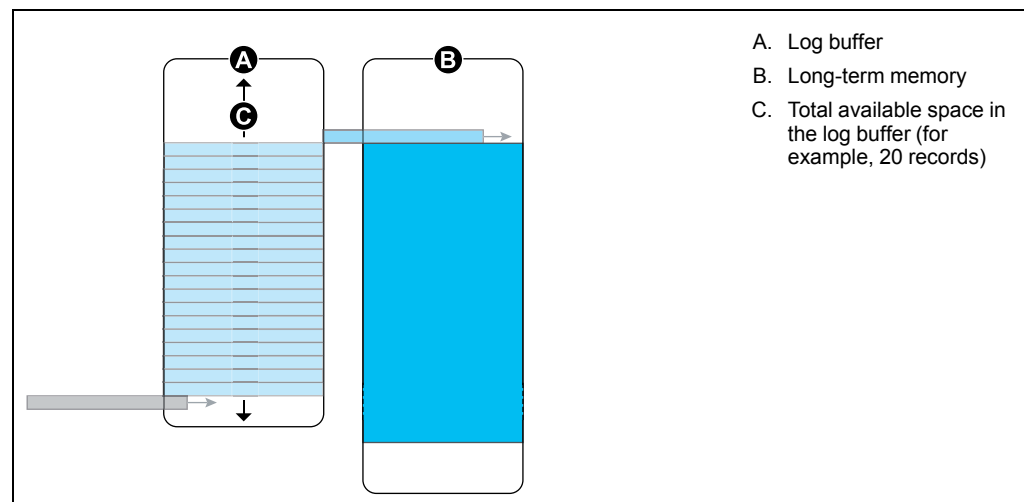

In this example, the buffer depth equals 20. The first record has already replicated to the long-term memory, making room in the log buffer for the new records (including the newest record, in gray).

### Example: Resulting gaps in data when a partially buffered log is full

However, depending on your configuration, there may be instances where the log buffer fills up faster than it can replicate records to long-term memory. In this case, you may lose records and see gaps in your data.

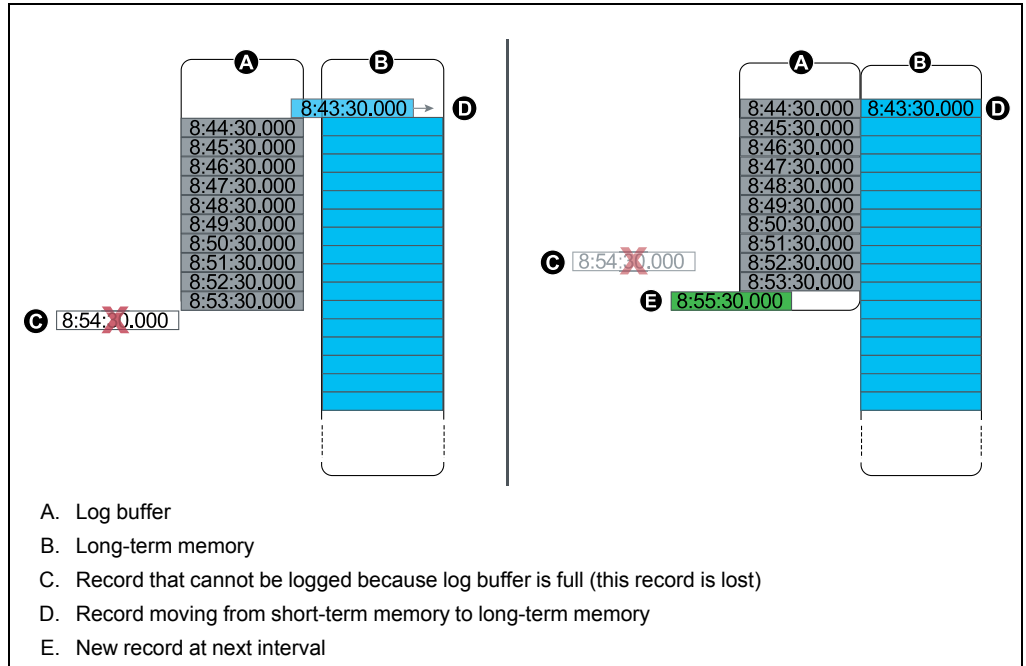

In the graphic on the left, the log buffer (A) is full, and the oldest record has not replicated to the long-term memory yet. This means that the new record (C) is not logged, and is permanently lost. In the graphic on the right, the oldest record (D) has been replicated to long-term memory, making space in the buffer. The new record at the next interval (E) is logged but there is a gap in the data for the lost record (C).

### Changing log interval and depth settings using ION Setup

You can configure log intervals, log depths and buffer depths to optimize your memory usage.

Before you begin, make sure you understand:

- the structure of the meter’s logging framework
- the meter’s existing logging configuration
- your data logging requirements

Changing your meter’s log configuration deletes all existing records from that log.

<b>NOTICE</b>
<p><b>DATA LOSS</b></p> <p><b>Failure to follow these instructions can result in data loss.</b></p> <p>Ensure that all important data has been recorded before configuring a log.</p>

The default log settings are designed to meet the needs of most users.

This procedure provides the steps for configuring settings for a subset of data logs using the ION Setup Assistant. Configuring these settings for custom logs, and logs not listed in the **Logging > Memory** screen, is an advanced procedure; see the ION Setup help for more information.

1. Start ION Setup.
2. Open the Setup Assistant for your meter.
3. Navigate to the **Logging > Memory** screen.

4. Select the log you want to edit and click **Edit**.
5. Set the log depth and log interval as required for your logging needs.
  - **Log Interval:** you can change the interval units to seconds, minutes, hours or days.
  - **Log Depth:** You can set the depth in time (seconds, hours, days, etc.) or the number of records.

**NOTE:** For some log types, you only set the log depth (for example, waveform recorders).

**Log Memory** shows the estimated impact of the changes on the total size of the log and **Log Storage** displays the estimated available log memory on the meter.

**NOTE:** If you receive a message stating that there is not enough memory when you change a log's configuration, check the configuration of your meter's other logs. You may not have enough RAM, or short-term memory, to allow for the new configuration. You may need to use ION Setup Advanced mode to check the detailed configuration of your logs.

6. Click **Finish**.

In some case, you may see a **Next** button instead of **Finish**. In this case, the next screen allows you to configure the buffer depth for the log. The screen displays the overall log depth and a field for setting the log buffer depth. It also shows the impact of the **Buffer Depth** setting to your meter's short-term memory (RAM).

## Data log memory calculations

The amount of memory required to store data and event logs depends on the number of parameters being logged and the frequency with which these parameters are logged.

You can use the following calculation to estimate the approximate amount of memory required for a data log:

Memory consumption for each record (in Bytes) = [(number of parameters x 5) + 8]

For example, a data log recording three parameters consumes 23 Bytes of data. If the data is recorded every 15 minutes for 35 days, the data log requires approximately 80 kiloBytes of logging memory.

See the ION Setup online help for more information about the logging memory allocations and other meter logging memory information displayed by the ION Setup Assistant.

## Waveform record memory calculations

The meter can simultaneously capture waveforms triggered by events on all channels to a maximum of 96 cycles for each waveform record.

You can use the following calculation to estimate the approximate amount of memory required for a waveform record:

Memory consumption for each waveform (in Bytes) = [2 x number of samples per cycle + 12] x [number of cycles in waveform x 2] + 32.

A single waveform record requires approximately 8 kB of memory.

See the ION Setup online help for more information about the logging memory allocations and other meter logging memory information displayed by the ION Setup Assistant.

# Inputs / outputs

## I/O Overview

Your meter has onboard digital I/O which can be increased by adding optional digital and analog I/O modules to expand your meter's I/O capabilities.

Your meter base has:

- 3 digital inputs
- 1 form A digital output
- 2 energy pulsing LEDs (one visible, one infrared)

You can view information about your meter's I/O through the display and webpages, and configure your meter's I/O using ION Setup.

**NOTE:** The digital outputs can handle voltages less than their specified maximum. For higher voltage applications, use an external relay in the switching circuit.

## Input/output ION modules

ION modules are used to configure your meter's digital or analog inputs/outputs (I/O).

You need to configure the following ION modules in order to use the meter's digital or analog I/O.

- Digital input: uses the Digital Input module, which tells the meter how to interpret incoming signals.
- Digital output: uses one of three ION modules depending on the application.
  - Digital Output module: monitors a change of state to control relay operation via a hardware output device.
  - Pulser module: transfers high-speed pulses to a hardware pulse counting device that is used to track energy usage.
  - Calibration Pulser module: integrates instantaneous power inputs, then outputs high-speed pulses to an LED that can be monitored for energy accuracy verification.

**NOTE:** All of these modules can act as intermediaries between the physical hardware port and the other modules in the meter. They define the characteristics of the outgoing signals.

- Analog input: uses the Analog Input module, which tells the meter how to interpret an incoming analog voltage or current signal from transducers.
- Analog output: uses the Analog Output module to deliver a continuous direct voltage or current analog signal to transducers.

## Input/output ION modules, ports and labels

You can configure the Digital Output, Digital Input, Analog Input, Analog Output, Pulser and Calibration Pulser ION modules to specify which port handles the outgoing or incoming signals.

To assign a port to one of these modules, simply modify the Port setup register by picking a port from the enumerated list.

The following tables describe the ports that can be configured to handle outgoing or incoming signals:

**Onboard input and output ports**

ION module type	ION module name	Hardware port (device label)	Port name (ION label)	Description
Digital Output	Port D1	D1	Port D1	Form A output
Calibration Pulser	Wh Pulser -LED	N/A	kWh Pulse LED	Energy pulsing
Digital Input	Port S1	S1	Port S1	Externally excited
	Port S2	S2	Port S2	Externally excited
	Port S3	S3	Port S3	Externally excited

**Option module(s) input and output ports**

ION module type	ION module name	Hardware port (device label)	Port name (ION label)	Description
Digital Input	Port A/B/C/D-S1 - S6	S1 - S6	Port A S1 - S6 Port B S1 - S6 Port C S1 - S6 Port D S1 - S6	Option module digital inputs
Digital Output	Port A/B/C/D D1 - D2	Relay 1 - Relay 2	Port A D1 - D2 Port B D1 - D2 Port C D1 - D2 Port D D1 - D2	Option module digital output
Analog Input	Port A/B/C/D A1 - A4	A1 - A4	Port A A1 - A4 Port B A1 - A4 Port C A1 - A4 Port D A1 - A4	Option module analog input
Analog Output	Port A/B/C/D Q1 - Q2	S1 - S6	Port A Q1 - Q2 Port B Q1 - Q2 Port C Q1 - Q2 Port D Q1 - Q2	Option module analog output

**NOTE:** When configuring your meter, the configuration interface may show all of the possible ports, regardless of what is physically available on your meter.

**Related Topics**

- Option modules overview

**I/O option modules**

I/O option modules provide increased digital and analog input/output (I/O) capabilities for your meter.

<b>⚠ WARNING</b>
<p><b>UNINTENDED OPERATION</b></p> <p><b>Failure to follow these instructions can result in death, serious injury or equipment damage.</b></p> <p>Do not use the meter for critical control or protection applications where human or equipment safety relies on the operation of the control circuit.</p>

These I/O modules can be used to monitor the status of breakers, control analog or digital transducers, or receive signals that can be interpreted to provide WAGES data

for your energy system. For applications requiring high accuracy, such as energy pulsing to verify accuracy, the digital output on the meter base is recommended.

Your meter's digital and analog outputs may change state during a firmware upgrade. Option modules are offline during an option module firmware upgrade; they will not communicate to the meter and the outputs may change state during the upgrade process.

Your meter's analog I/O option modules can measure and output either low voltage or current using standard analog transducers such as 4 - 20 mA current transducers.

## Analog I/O option module data viewing

View analog I/O option module data from the webpages and display.

To view analog option module data on your meter's display, go to **Inputs/Outputs** and select either **Analog Inputs** or **Analog Outputs**. If there are no I/O of the specified type, an informative message is displayed.

To view analog option module data on your meter's webpages, connect to your meter's webpages, go to **Monitoring > Inputs/Outputs** and select either **Analog Inputs** or **Analog Outputs**. If there are no I/O of the specified type, an informative message is displayed.

## Digital I/O option module data viewing

View digital I/O option module data from the webpages and display.

To view digital option module data on your meter's display, go to **Inputs/Outputs** and select either **Digital Inputs** or **Digital Outputs**. If there are no I/O of the specified type, an informative message is displayed.

To view digital option module data on your meter's webpages, connect to your meter's webpages, go to **Monitoring > Inputs/Outputs** and select either **Digital Inputs** or **Digital Outputs**. If there are no I/O of the specified type, an informative message is displayed.

## Option I/O modules configuration

You can configure your meter's I/O option modules using ION Setup.

The I/O option module screen has tabs corresponding to the possible option modules, which are identified based on how the option modules are connected to the meter. Each tab indicates the module's type and status, and has an area where the module's ports are listed for viewing and configuration. You can also reset your meter's option modules using ION Setup.

Status examples	Description
None	No option module detected
Normal	The option module is operating normally
Option module added	A new option module is detected
Option module removed	The option module has been removed
Invalid SI9	The option module's firmware is not supported
Invalid card	The option module type is not supported

## Related Topics

- Configuring option module analog inputs using ION Setup
- Configuring option module analog outputs using ION Setup
- Configuring option module digital inputs using ION Setup
- Configuring option module digital outputs using ION Setup

## Analog inputs

### Analog input applications

You can use an analog input to monitor an analog flowmeter to monitor how much water flows through a pipe.

For analog input operation, your meter takes an analog input signal and provides the resulting scaled value.

Your meter's analog I/O option modules can measure either low voltage or current using standard analog transducers such as 4 - 20 mA current transducers.

## Related Topics

- Option modules

### Analog input voltage and current mode

You can set the analog input's mode for voltage or current sensing.

In current mode, the analog inputs have a low input resistance while the meter is powered on, and a high input resistance when the meter is powered off. In voltage mode, the analog inputs have a high input resistance regardless of whether the meter is powered or not.

**NOTE:** When unpowered, your meter's analog inputs act like they are in voltage mode (high input resistance).

When connected to a current output transducer, this high resistance can create a high voltage. Standard (i.e., 4 to 20 mA) current transducers have open circuit protection and are able to handle a high input resistance; however, if non-standard transducers are used high voltages may be generated. Your meter's analog input has circuitry to limit this voltage, but it may not be sufficient with a very high-power current source.

## **NOTICE**

### **EQUIPMENT DAMAGE**

**Failure to follow these instructions will result in equipment damage.**

- Ensure the analog input is configured for the correct voltage or current mode before connecting or activating the current transducer.
- Do not exceed the device's ratings for maximum limits.

## Related Topics

- Specifications overview

### Analog input behavior

Analog inputs may show a value below zero scale if an open circuit is detected on the input port.

## Analog input zero scale and full scale values

Configure your analog input's zero and full scale values.

In most cases the output range of the sensor feeding the analog input matches the hardware limits of your meter's analog input port. In that case, the analog input's zero scale and full scale values are the same as the sensor's represented range. For example:

Analog sensor	Meter's analog input	Analog input values
0 - 50 psi represented by a 4 - 20 mA signal	4 - 20 mA analog input range	Full scale = 50 (psi) Zero scale = 0 (psi)

If the sensor's output range does not match your meter's hardware limits, you must calculate the full scale and/or zero scale values by analyzing the system.

See the ION Reference, available from [www.usa.siemens.com/pds](http://www.usa.siemens.com/pds), for detailed information about the Analog Input module and full scale and zero scale calculations.

## Configuring option module analog inputs using ION Setup

You can configure analog inputs using ION Setup.

Analog inputs are available on the optional I/O modules you can connect to the base of your meter.

Calculate your zero scale and full scale values based on the analog source and the input range of your meter.

Make sure that the analog input port that you want to use is properly configured and connected to a valid external analog signal source.

1. Start ION Setup.
2. Open the Setup Assistant for your meter.
3. Navigate to **Expansion Module > Option I/O Modules** and select the module tab that corresponds to the option module with the analog input you want to configure.
4. Select the analog input channel and click **Edit**. The setup screen for that analog input is displayed.
5. Configure the analog input by selecting the parameter and clicking **Edit**.

Parameter	Value/Range	Description
Zero scale	0 to $\pm 10^9$	The minimum source value that matches the minimum analog input signal.
Full scale	0 to $\pm 10^9$	The maximum source value that matches the maximum analog input signal.
Port	–	The physical analog input port connection.
Mode	Voltage, current	Determines whether the analog input is monitoring voltage or current.

## Related Topics

- Option I/O modules configuration

## Analog outputs

### Analog output applications

You can use an analog output to send a signal to an analog-controlled valve to modify a water pipe's valve position in order to change the flow rate.

For analog output operation, your meter takes an input value and scales it to the appropriate signal value to send out the physical analog output port.

Your meter's analog I/O option modules can output either low voltage or current using standard analog transducers such as 4 - 20 mA current transducers.

## Related Topics

- Option modules

### Analog output behavior

Your meter's analog output, once configured, outputs voltage or current signals. If your meter's analog output source becomes unavailable (N/A) the analog output level should go to zero (0 V / 0 mA) under most conditions.

When your meter is powered off or configured to send voltage, the meter registers as a high impedance.

The electrical signal on the analog output is DC; make sure proper polarity is observed when wiring external devices to the analog output ports.

An unexpected change of state of the analog outputs can result when the supply power to the meter is interrupted, during an upgrade of the meter's firmware or framework or option module firmware or a during an option module reset.

## ▲ WARNING

### UNINTENDED OPERATION

**Failure to follow these instructions can result in death, serious injury, or equipment damage.**

Do not use this device for critical control or protection applications where human or equipment safety relies on the operation of the control circuit.

### Analog output zero scale and full scale values

Configure your analog output's zero and full scale values.

In most cases your meter's analog output range matches the range of the analog sensors that your meter's outputs are connected to. In that case, your meter's analog output zero scale and full scale values are the maximum and minimum values of the source driving your meter's analog output. These values are used to normalize the source value to a value between 0 and 1 which is applied to the operating range of the analog output port to determine the analog output current or voltage. For example:

Source value	Analog output values	Meter's analog output	Analog sensor
0 to 120 kW range 100 kW	Full scale = 120 (kW) Zero scale = 0 (kW) Normalized: 0.83	4 - 20 mA range Output: 17.28 mA	4 - 20 mA range

If your meter's analog output range does not match the range of the connected analog sensor, you must calculate the full scale and zero scale values by analyzing the system.

See the ION Reference, available from [www.usa.siemens.com/pds](http://www.usa.siemens.com/pds) for detailed information about the Analog Output module and full scale and zero scale calculations.

## Configuring option module analog outputs using ION Setup

You can configure option module analog outputs using ION Setup.

Analog outputs are available on the optional I/O modules you can connect to the base of your meter.

Calculate your zero scale and full scale values based on the measured value and the analog output range of your meter.

Make sure that the analog output port that you want to use is properly connected to an analog receiver.

1. Start ION Setup.
2. Open the Setup Assistant for your meter.
3. Navigate to **Expansion Module > Option I/O Modules** and select the module tab that corresponds to the option module with the analog output you want to configure.
4. Select the analog output channel and click **Edit**. The setup screen for that analog output is displayed.
5. Configure the analog output by selecting the parameter and clicking **Edit**.

Parameter	Value/Range	Description
Zero scale	0 to $\pm 10^9$	The minimum source value that matches the minimum analog output signal.
Full scale	0 to $\pm 10^9$	The maximum source value that matches the maximum analog output signal.
Port	–	The physical analog output port connection.
Mode	Voltage, current	Determines whether the analog output is monitoring voltage or current.

### Related Topics

- Option I/O modules configuration

## Digital inputs

### Digital input applications

Digital inputs are typically used for monitoring the status of contacts, such as status contacts on circuit breakers.

They can also be used for pulse counting or input metering applications, such as WAGES (water, air, gas, electricity, steam) monitoring, or conditional energy applications, or IRIG-B time synchronization.

### IRIG-B time synchronization

You can use a digital input to synchronize the meter time to an IRIG-B time source.

You can connect an IRIG-B time source to one of meter's digital inputs for IRIG-B time synchronization; for improved accuracy use the digital inputs on the meter base. For IRIG-B time synchronization, you must configure both the meter's digital input and the meter's clock.

### Related Topics

- Configuring time and time synchronization using ION Setup

## Configuring onboard digital inputs using ION Setup

You can use ION Setup to configure your meter's digital inputs.

Digital inputs are available on your meter. You can add more digital inputs using optional I/O modules.

1. Start ION Setup.
2. Open the Setup Assistant for your meter.
3. Navigate to **I/O > Digital Inputs**. The tabs correspond to each digital input. Click on the tab for the digital input you want to edit.
4. Configure the digital input by selecting the parameter and clicking **Edit**.
5. Once the parameter has been configured, click **OK** to save the setting to the meter.

Parameter	Value/range	Description
Input Mode	Pulse, KYZ, A/C, IRIG-B <sup>1</sup>	Specifies how the meter processes the signal: <ul style="list-style-type: none"> <li>• Pulse: the meter counts an entire pulse (from off-on to on-off) as one input.</li> <li>• KYZ: the meter counts a transition (from off-on or from on-off) as one input.</li> <li>• A/C: the meter detects analog signals where the ON condition is based on the presence of an AC signal</li> <li>• IRIG-B<sup>1</sup>: the meter detects an IRIG-B time synchronization signal.</li> </ul>
Polarity	Inverting/Non-Inverting	Specifies if the signal from the digital port is inverted or not inverted.
Debounce	0.000 - 1.000	Specifies how long (in seconds) the signal must remain in a state to be considered a valid state change.
Port	Defined by your meter's hardware	Your meter's physical digital input port.

<sup>1</sup> IRIG-B can only be connected to one of the digital inputs located on the meter base, not an option module. You must also configure your meter's clock to use IRIG-B time synchronization.

## Configuring option module digital inputs using ION Setup

You can configure option module digital inputs using ION Setup.

Digital inputs are available on your meter. You can add more digital inputs using optional I/O modules.

1. Start ION Setup.
2. Open the Setup Assistant for your meter.

3. Navigate to **Expansion Module > Option I/O Modules** and select the module tab that corresponds to the option module with the digital input you want to configure.
4. Select the digital input channel and click **Edit**.  
The setup screen for that digital input is displayed.
5. Configure the digital input by selecting the parameter and clicking **Edit**.
6. Once the parameter has been configured, click **OK** to save the setting to the meter.

Parameter	Value/Range	Description
Input Mode	Pulse, KYZ, A/C, IRIG-B <sup>1</sup>	Specifies how the meter processes the signal: <ul style="list-style-type: none"> <li>• Pulse: the meter counts an entire pulse (from off-on to on-off) as one input.</li> <li>• KYZ: the meter counts a transition (from off-on or from on-off) as one input.</li> <li>• A/C: the meter detects analog signals where the ON condition is based on the presence of an AC signal.</li> <li>• IRIG-B<sup>1</sup>: the meter detects an IRIG-B time synchronization signal.</li> </ul>
Polarity	Inverting/Non-Inverting	Specifies if the signal from the digital port is inverted or not inverted.
Debounce	0.000 - 1.000	Specifies how long (in seconds) the signal must remain in a state to be considered a valid state change.
Port	Defined by your meter's hardware	Your meter's physical digital input port.

<sup>1</sup> IRIG-B can only be connected to one of the digital inputs located on the meter base, not an option module.

## Related Topics

- Option I/O modules configuration

## WAGES monitoring

WAGES monitoring allows you to record and analyze all energy sources and utilities usage.

Your energy system may use several different types of energy. For example, you may consume steam or compressed air for industrial processes, electricity for lights and computers, water for cooling and natural gas for heating. WAGES monitoring collects the usage information from all these different energy sources to enable a more complete energy analysis.

WAGES information can help you:

- Identify losses or inefficiencies.
- Modify demand to reduce costs.
- Optimize energy source usage.

## WAGES example

This example shows WAGES monitoring for a water flow meter.

You can connect your meter's digital input to a transducer that sends a pulse for every 15 kiloliters (4000 US Gal) of water. After configuring an input metering channel and assigning it to the digital input, the meter is able to detect and record the incoming pulses. An energy management system can then use the information from the meter to perform WAGES analysis.

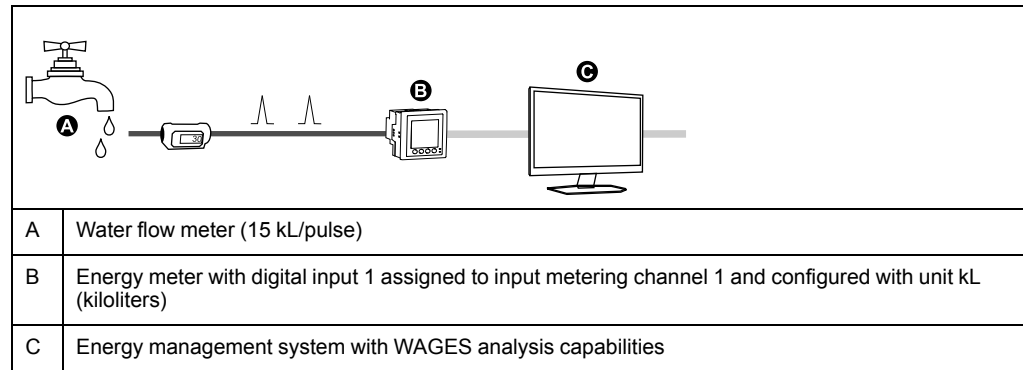

## Input metering

Your meter's digital inputs can be used to count pulses from transducers and convert the pulses to energy measurements.

Your meter's input metering channels count pulses received from the digital inputs assigned to that channel. The incoming pulses are used in calculating and measuring consumption data (e.g., BTU, kWh, L, kg). Each channel must have the following values configured to match the pulse data:

- Pulse Weight: the pulses per unit value.
- Unit Code: the unit of measure associated with the monitored value.
- Demand Code: for time-based values (such as kWh), this provides the associated demand units (kW) for demand calculations; for other values (such as kg), this can be configured to provide rate information (kg/h or kg/s).
- Mode: whether a pulse is based on a complete pulse or a transition.

For example, if each complete pulse represents 125 Wh, you can configure for Wh pulsing as follows:

- Pulse Weight = pulses/Wh =  $1/125 = 0.008$
- Unit Code = Wh
- Demand Code = kW (this is automatically set)
- Mode = pulse

If you want to configure for kWh pulsing, you must adjust the pulse weight calculation and unit code as follows:

- Pulse Weight = pulses/kWh =  $1/0.125 = 8$
- Unit Code = kWh

## Configuring standard input metering using ION Setup

You can configure input metering with standard units and rates using ION Setup

When configuring your meter, the configuration interface may show all of the possible ports, regardless of what is physically available on your meter.

**NOTE:** Your device's digital input must be connected to the input metering pulse source. Review the digital inputs assigned to applications to help you understand your existing configuration.

1. Start ION Setup.
2. Open the Setup Assistant for your meter.
3. Navigate to **Energy Applications > Digital Input Based**.

4. Select the input metering channel you want to configure and click **Edit**. The **Input Metering Channel Setup** screen is displayed.
5. Select **Enabled** to enable the input metering feature.
6. Click **Select** to define which digital input is the pulse source for the input metering channel.

**NOTE:** It is recommended to set **Assigned Input** to No connection to disable the input metering channel by removing any port associations.

7. Configure the remaining parameters as required.
8. Click **OK** to save your configuration.
9. Configure your meter to log the input metering data if required.

Parameter	Description
Pulse Weight	Enter the value per pulse.
Units	Select the measurement units associated with the pulse.
Demand Period	Enter the frequency in minutes that input metering data is calculated in your energy management system.
Rate	Select the rate associated with the defined Units.
Source ID	Enter a data identifier. This value is added to the input metering channel's data to uniquely identify the data within your energy management system.

## Configuring custom input metering using ION Setup

You can configure input metering with custom units and rates using ION Setup.

When configuring your meter, the configuration interface may show all of the possible ports, regardless of what is physically available on your meter.

**NOTE:** Your device's digital input must be connected to the input metering pulse source. Review the digital inputs assigned to applications to help you understand your existing configuration.

1. Start ION Setup.
2. Open the Setup Assistant for your meter.
3. Navigate to **Energy Applications > Digital Input Based**.
4. Select the input metering channel you want to configure and click **Edit**. The **Input Metering Channel Setup** screen is displayed.
5. Select **Enabled** to enable the input metering feature.
6. Click **Select** to define which digital input is the pulse source for the input metering channel.

**NOTE:** It is recommended to set **Assigned Input** to No connection to disable the input metering channel by removing any port associations.

7. Clear the **Standard quantity** checkbox. The screen changes to display custom input metering parameters.
8. Configure the remaining parameters as required.
9. Click **OK** to save your configuration.

## 10. Configure your meter to log the input metering data if required.

Parameter	Description
Pulse Weight	Enter the value per pulse.
Units	Select the measurement units associated with the pulse. <b>NOTE:</b> Include source identification information by entering "@" followed by the source identifier.
Demand Period	Enter the frequency in minutes that input metering data is calculated in your energy management system.
Rate	Select the rate associated with the defined Units.
Scaling	Select the scaling value based on the relationship between Units and Rate.
Time Base	Select the value and units to match the Rate.

## Digital outputs

### Digital output applications

Digital outputs are typically used in switching applications, for example, to provide on/off control signals for switching capacitor banks, generators, and other external devices and equipment.

The digital output can also be used in demand synchronization applications, where the meter provides pulse signals to the input of another meter to control its demand period. The digital output can also be used in energy pulsing applications, where a receiving device determines energy usage by counting the kWh pulses coming from the meter's digital output port.

### Related Topics

- Option modules

### Configuring onboard digital outputs using ION Setup

You can use ION Setup to configure your meter's digital outputs.

One form A digital output is available on the base of the meter. You can add more digital outputs using optional I/O modules.

1. Start ION Setup.
2. Open the Setup Assistant for your meter.
3. Navigate to either onboard or expansion I/O, Digital Outputs, and select a digital output tab.

4. Configure the digital output by selecting the parameter and clicking **Edit**.

Parameter	Value/range	Description
Source	Digital/Boolean	Link this input to the value that drives the state of the digital output. If Source is not linked, the digital output state is driven by the Force ON, Force OFF values.
Force ON	Pulse	Link this input to a pulse that forces the digital output on for the PulseWidth duration, regardless of the Source input.
Force OFF <sup>1</sup>	Pulse	Link this input to a pulse that forces the digital output off.
Normal <sup>1</sup>	Pulse	Pulsing this input will switch the driver of the digital output from Force ON to Source.
Polarity	Inverting/non-inverting	Specifies if the signal to the digital port is inverted or not inverted.
PulseWidth	0 - 2,000,000	Specifies the duration of the pulse, in seconds. Setting this parameter to 0 sets the digital output continuously on.
Port	—	The physical digital output port connection. Only available ports are shown.

<sup>1</sup> These parameters are only valid when pulse width is set to 0.

## Configuring option module digital outputs using ION Setup

You can configure option module digital outputs using ION Setup.

One form A digital output is available on the base of the meter. You can add more digital outputs using optional I/O modules.

1. Start ION Setup.
2. Open the Setup Assistant for your meter.
3. Navigate to **Expansion Module > Option I/O Modules** and select the module tab that corresponds to the option module with the digital output you want to configure.
4. Select the digital output channel and click **Edit**. The setup screen for that digital output is displayed.

5. Configure the digital output by selecting the parameter and clicking **Edit**.

Parameter	Value/Range	Description
Source	Digital/Boolean	Link this input to the value that drives the state of the digital output. If Source is not linked, the digital output state is driven by the Force ON, Force OFF values.
Force ON	Pulse	Link this input to a pulse that forces the digital output on for the PulseWidth duration, regardless of the Source input.
Force OFF <sup>1</sup>	Pulse	Link this input to a pulse that forces the digital output off.
Normal <sup>1</sup>	Pulse	Pulsing this input will switch the driver of the digital output from Force ON to Source.
Polarity	Inverting/non-inverting	Specifies if the signal to the digital port is inverted or not inverted.
PulseWidth	0 - 2,000,000	Specifies the duration of the pulse, in seconds. Setting this parameter to 0 sets the digital output continuously on.
Port	–	The physical digital output port connection. Only available ports are shown.

<sup>1</sup> These parameters are only valid when pulse width is set to 0.

### Related Topics

- Option I/O modules configuration

## Energy pulsing

### Energy pulsing

You can configure the meter's energy pulsing LED or digital output for energy pulsing applications.

When the LED is set to energy pulsing, the meter sends a readable pulse or signal based on the measured energy. This pulse can be used for accuracy verification or as an input to another energy monitoring system. You must calculate your pulse values as either pulses per kWh or as kWh per pulse, as defined by your meter, and set the energy value as delivered or received active, reactive, or apparent energy.

### Calculate your maximum kWh/pulse (pulse weight) value

To calculate the kWh/pulse (pulse weight) value, divide the highest kW value you can expect by the required pulse rate.

Make sure the required pulse rate does not exceed the maximum pulse rate for the digital output.

**NOTE:** To convert from kWh/pulse to pulse/kWh you must invert (take the reciprocal) of the value. For example, 1.8 kWh/pulse becomes 0.556 pulse/kWh.

#### Example pulse weight calculation

For a maximum load of 1600 kW and a pulse rate of 2 pulses per second, calculate the kWh/pulse value as follows:

1. Convert 1600 kW load into kWh/second:  
 $(1600 \text{ kW}) \times (1 \text{ hr}) = 1600 \text{ kWh}$   
 $(1600 \text{ kWh}) / (3600 \text{ sec}) = (X \text{ kWh}) / (1 \text{ sec})$   
 $X = 0.444 \text{ kWh/sec}$

2. Calculate the kWh required per pulse:  
 $(0.444 \text{ kWh/sec}) / (2 \text{ pulses per second}) = 0.222 \text{ kWh/pulse}$
3. Adjust for the KY giving one pulse per 2 transitions if necessary.  
 $(0.222 \text{ kWh/pulse}) / (2) = 0.111 \text{ kWh/pulse}$

# Alarms and alerts

## Alarms overview

An alarm is the meter's means of notifying you when an alarm condition is detected, such as an error or an event that falls outside of normal operating conditions.

You can configure your meter to generate and display high, medium and low priority alarms when predefined events are detected in the meter's measured values or operating states. Your meter also logs the alarm event information. Your meter comes with many alarms. Some alarms are preconfigured, while others need to be configured before your meter can generate alarms. Your meter's default alarms can be customized, as needed, such as changing the priority. You can create custom alarms using the advanced features of your meter.

## Alarm types

Your meter has four types of alarms.

Type	Description
Setpoint (standard)	Setpoint alarms define an alarm by comparing the actual value of a parameter to a specified limit or range of values. These include measured voltage and current values and calculated power quality values.  Some setpoint alarms use high-speed measurements for up to 1 millisecond resolution.
Digital	Digital alarms define an alarm condition based on a digital input's on/off state.
Disturbance (sag/swell)	Disturbance alarms define an alarm based on a measured sag or swell.
Unary	Unary alarms are not configurable, and generate an alarm based on the meter's state, for example, the meter powering up.

Alarms have two states:

- Active: the meter detects the alarm condition is met.
- Historical: the alarm condition previously existed but the condition has since returned to a non-alarm state.

See the *ION reference*, available from [www.usa.siemens.com/pds](http://www.usa.siemens.com/pds), for more information about Setpoint, Digital Input and Sag/Swell modules.

## Standard alarms

Standard alarms are setpoint-driven alarms monitor certain behaviors, events or unwanted conditions in your electrical system.

Standard alarms have a detection rate equal to the 50/60 meter cycle, which is nominally 1 second if the meter's frequency setting is configured to match the system frequency (50 or 60 Hz).

Many of the standard alarms are three-phase alarms. Alarm setpoints are evaluated for each of the three phases individually, but the alarm is reported as a single alarm. The alarm pickup occurs when the first phase exceeds the alarm pickup magnitude for the pickup time delay. The alarm is active as long as any phase remains in an alarm state. The alarm dropout occurs when the last phase drops below the dropout magnitude for the dropout time delay.

### Example of over and under setpoint (standard) alarm operation

The meter supports over and under setpoint conditions on standard alarms.

A setpoint condition occurs when the magnitude of the signal being monitored crosses the limit specified by the pickup setpoint setting and stays within that limit for a minimum time period specified by the pickup time delay setting.

The setpoint condition ends when the magnitude of the signal being monitored crosses the limit specified by dropout setpoint setting and stays within that limit for a minimum time period specified by dropout time delay setting.

#### Over setpoint

When the value rises above the pickup setpoint setting and remains there long enough to satisfy the pickup time delay period ( $\Delta T1$ ), the alarm condition is set to ON. When the value falls below the dropout setpoint setting and remains there long enough to satisfy the dropout time delay period ( $\Delta T2$ ), the alarm condition is set to OFF.

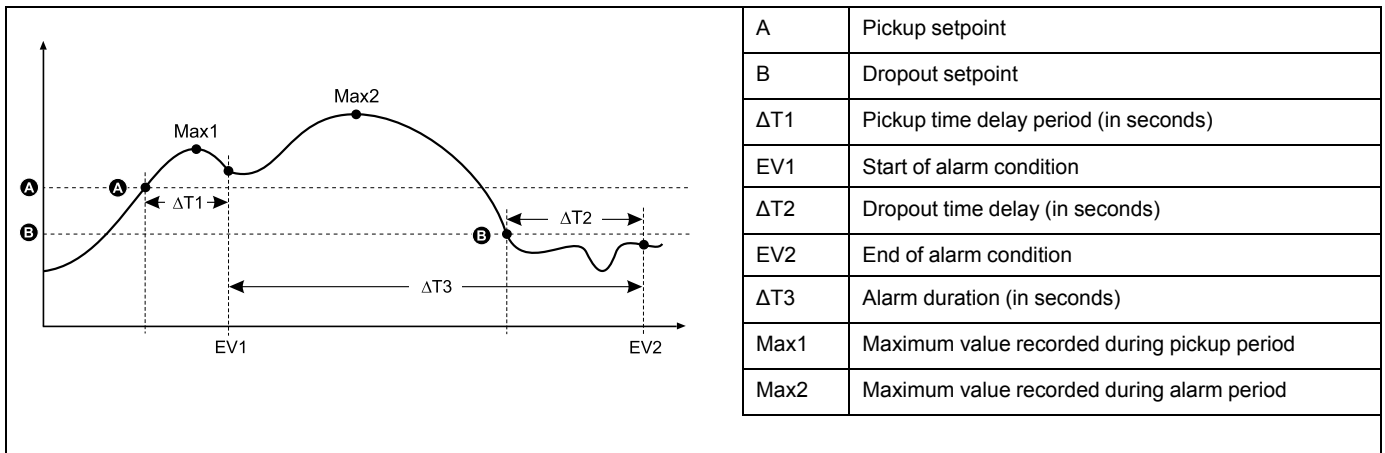

The meter records the date and time when the alarm event starts (EV1) and when it ends (EV2). The meter also performs any task assigned to the event, such as operating a digital output. The meter also records maximum values (Max1, Max2) before, during or after the alarm period.

#### Under setpoint

When the value falls below the pickup setpoint setting and remains there long enough to satisfy the pickup time delay period ( $\Delta T1$ ), the alarm condition is set to ON. When the value rises above the dropout setpoint setting and remains there long enough to satisfy the dropout time delay period ( $\Delta T2$ ), the alarm condition is set to OFF.

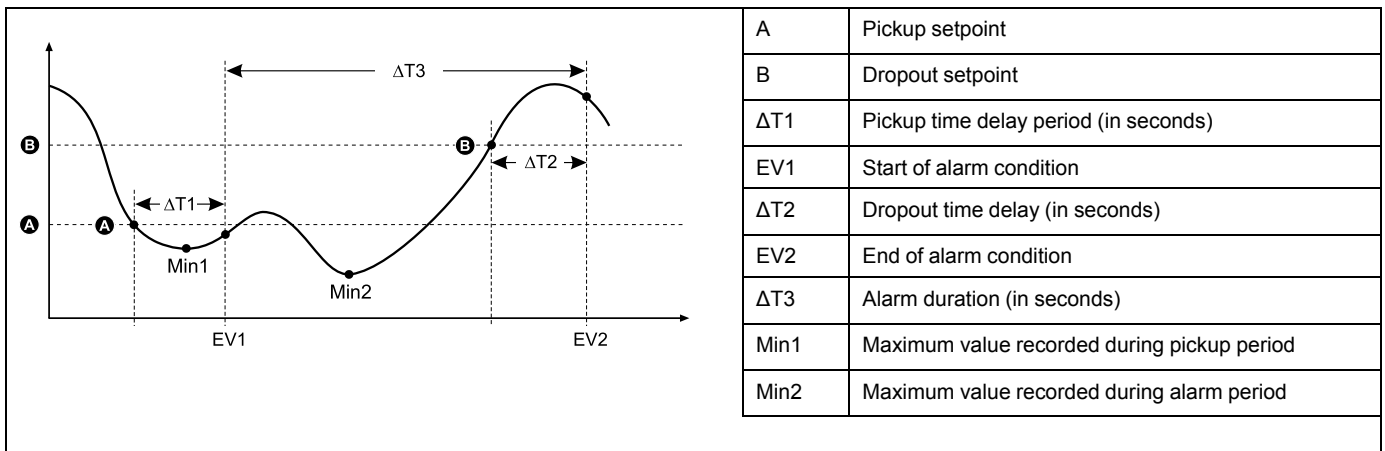

The meter records the date and time when the alarm event starts (EV1) and when it ends (EV2). The meter also performs any task assigned to the event, such as operating a digital output. The meter also records minimum values (Min1, Min2) before, during or after the alarm period.

## Relative setpoint

The meter supports high-speed Relative Setpoint modules for capturing events with half-cycle time intervals.

The meter's Relative Setpoint modules behave similarly to the Setpoint modules, except the pickup and dropout levels are set relative to the *Nominal* input source.

For more information on Relative Setpoint modules, download *ION Reference* at [www.usa.siemens.com/pds](http://www.usa.siemens.com/pds).

## Disturbance (sag/swell) alarms

These alarms are triggered by voltage and current disturbances.

You must configure nominal voltage and current for these alarms to function.

For voltage disturbances, enter the percentage deviation from the nominal that defines a sag or swell.

For current disturbances, enter the percentage deviation from the nominal that defines the pickup and dropout points for a current sag or a current swell.

## Digital alarms

These alarms are triggered when the associated digital input changes state.

You can configure the alarm to be active when the digital input is on or off, depending on the alarm's purpose.

For example, if you used a digital input to monitor a breaker that is always supposed to be on, you would set the alarm to be active when the breaker has tripped.

**NOTE:** To stop a digital alarm from being displayed, set the alarm priority to **Info Only**. Disabling (force off) the digital alarm off will disable all functions of the associated digital input.

See the ION Reference, available from [www.usa.siemens.com/pds](http://www.usa.siemens.com/pds), for more information about the Setpoint and Relative Setpoint module, Digital Input module, Sag/Swell module and Disturbance Analyzer modules.

### Related Topics

- Configuring sag/swell alarms using ION Setup

## Alarm event priorities

Your meter's alarm priorities correspond to event priority ranges.

Alarm priority	Event priority
High (red)	192 - 255
Medium (yellow)	128 - 191

Alarm priority	Event priority
Low (blue)	64 - 127
Info Only (no alarm) <sup>1</sup>	1 - 63
None (no alarm or event) <sup>1</sup>	0

<sup>1</sup> Alarms with priority of Info Only or None are not indicated or displayed.

## Info Only and None event priority

Alarms with a priority of **Info Only** or **None** are not shown on the meter's display, and do not function as alarms. If the alarm's priority is set to **Info Only**, and the event priority is greater than the event log cutoff value, the associated event is recorded in the meter's event log. If the alarm's priority is set to **None**, the event priority is automatically set to zero, and no associated event is logged in the meter's event log.

For events that you want to log for future reference or troubleshooting, but don't want alarm functions, set the alarm priority to **Info Only**.

For nuisance events that frequently occur and you have no desire to log for reference or troubleshooting, set the alarm priority to **None**.

## Related Topics

- Event log overview

## Alarm indicators

Your meter's display has an alarm indicator to show you what alarm levels have been detected (active or historic) and whether they have been acknowledged.

For active high priority alarms, the meter's display will also flash until the alarm is acknowledged. There is also an alarm LED to indicate the meter's alarm condition.

Alarm	Alarm icon	Alarm icon flash	Alarm LED	Meter display
Active high	Red solid bell	Flash if not acknowledged	<ul style="list-style-type: none"> <li>• Flash if not acknowledged</li> <li>• Steady if acknowledged</li> </ul>	Flash if not acknowledged
Active medium	Yellow solid bell	Flash if not acknowledged	<ul style="list-style-type: none"> <li>• Flash if not acknowledged</li> <li>• Steady if acknowledged</li> </ul>	No flash
Active low	Blue solid bell	Flash if not acknowledged	<ul style="list-style-type: none"> <li>• Flash if not acknowledged</li> <li>• Steady if acknowledged</li> </ul>	No flash
Historic high	Red outline bell	Flash if not acknowledged	<ul style="list-style-type: none"> <li>• Flash if not acknowledged</li> <li>• Steady if acknowledged</li> </ul>	No flash
Historic medium	Yellow outline bell	Flash if not acknowledged	<ul style="list-style-type: none"> <li>• Flash if not acknowledged</li> <li>• Steady if acknowledged</li> </ul>	No flash

Alarm	Alarm icon	Alarm icon flash	Alarm LED	Meter display
Historic low	Blue outline bell	Flash if not acknowledged	<ul style="list-style-type: none"> <li>Flash if not acknowledged</li> <li>Steady if acknowledged</li> </ul>	No flash
No active or unacknowledged alarms	Gray solid bell	No flash	Off	No flash

If there are multiple active alarms, the meter displays the alarm condition associated with the most important active alarm. If there are multiple unacknowledged historic alarms, the meter displays the alarm condition associated with the most important unacknowledged historic alarm.

**NOTE:** To stop an alarm from being displayed without impacting other metering features, set the alarm priority to **Info Only**.

## Default alarms

Your meter comes with default alarms.

**NOTE:** Some alarms require configuration in order to operate.

Name	Priority	Description
Current Sag Ph1 - 3	High	Current sag alarms for phase 1, 2, 3
Current Swell Ph1 - 3	High	Current swell alarms for phase 1, 2, 3
Sag/Swell	High	Voltage sag/swell alarm
Over I unbal	Medium	Over unbalanced current alarm
Over V unbal	Medium	Over unbalanced voltage alarm
Over THD V1 - 3	Medium	Over total harmonic distortion (THD) voltage alarms
Over kW (P) sd	Medium	Over kW sliding demand alarm
Over I a - c, (1 -3) 4	Medium	Over current alarms
V1 - V3 Setpoint	Medium	Voltage setpoint alarms
Freq Setpoint	Medium	Frequency setpoint alarm
4-30 Volt Intrap Ph1 - 3	Low	4-30 voltage interruption power quality alarms
Digital In	Info Only	Digital input alarms Number of alarms determined by the total number of available digital inputs <b>NOTE:</b> These alarms are not displayed by default.

## Alarm information

You can view information about an alarm from your meter's display.

Only alarms with a priority of low, medium or high are displayed.

Parameter	Description
Alarm	The name of the alarm (for example, Over THD V1).
Priority	Low, medium or high alarm priority.
Date	The date and time the alarm was triggered.
Duration	The duration of the alarm (only applies to inactive alarms).

Parameter	Description
Ack	The date and time when the alarm was acknowledged (only applies to acknowledged alarms).
Value	Active alarm: The maximum value detected when the alarm was triggered. Historic alarm: The maximum value detected during the duration of the alarm.

## Viewing and acknowledging alarms using the meter's display

You can view and acknowledge alarms using your meter's display

1. Press the home button to display your meter's data screen menu.
2. Navigate to **Alarms > Active Alarms** to view and acknowledge active alarms, or navigate to **Alarms > Historic Alarms** to view and acknowledge alarms that are no longer active.
3. Use the up and down arrows to view the different alarms. Press the info button to view details of the selected alarm.
4. To acknowledge all active or historic alarms, press the up and down arrow button simultaneously. A green checkmark appears by the acknowledged alarms, and the alarm indicators are updated.

## Alarm configuration

### Disabling alarms through your meter's display

You can disable alarms through the meter's display when you are performing maintenance tasks on your system and want to prevent nuisance alarms.

**NOTE:** To stop an alarm from being displayed without impacting other metering features, set the alarm priority to **Info Only**.

<b>⚠ WARNING</b>
<b>INACCURATE DATA RESULTS</b>
<b>Failure to follow these instructions can result in death, serious injury, or equipment damage.</b>
Confirm your alarm is properly configured.

1. Navigate to **Setup Menu > Alarm Setup**. Press the edit button to access the enable/disable screen. Use the up and down arrows to scroll through the available alarms. Simultaneously press the up and down arrow to enable or disable the highlighted alarm.
2. Press the select button to confirm your settings.
3. Complete the system maintenance tasks.

4. Enable the alarms you disabled in step 1.

## Related Topics

- Meter setup using your meter's display

## Alarm setup

You can disable alarms through the display in order to prevent nuisance alarms.

### Alarm setup

<b>⚠ WARNING</b>
<b>INACCURATE DATA RESULTS</b>
<b>Failure to follow these instructions can result in death, serious injury, or equipment damage.</b>
Do not use data displayed on the display or in software as a substitute for proper workplace practices or equipment maintenance.

Parameter <sup>1</sup>	Description
Over I unbal	Over unbalanced current alarm
Over THD V1	V1 over total harmonic distortion (THD) voltage alarm
Over THD V2	V2 over total harmonic distortion (THD) voltage alarm
Over THD V3	V3 over total harmonic distortion (THD) voltage alarm
Over P sd	Over kW sliding demand alarm
Over Ia	Ia over current alarm
Over Ib	Ib over current alarm
Over Ic	Ic over current alarm
Over I4	I4 over current alarm
Over V unbal	Over unbalanced voltage alarm
V1 Setpoint	V1 setpoint alarm
V2 Setpoint	V2 setpoint alarm
V3 Setpoint	V3 setpoint alarm
Freq Setpoint	Frequency setpoint alarm
Sag/Swell 1	Voltage sag/swell alarm
Current Sag Ph1	Current sag alarms for phase 1
Current Sag Ph2	Current sag alarms for phase 2
Current Sag Ph3	Current sag alarms for phase 3
4-30 Volt Intrp Ph1	4-30 voltage interruption power quality alarm for phase 1
4-30 Volt Intrp Ph2	4-30 voltage interruption power quality alarm for phase 2
4-30 Volt Intrp Ph3	4-30 voltage interruption power quality alarm for phase 3
Current Swell Ph1	Current swell alarms for phase 1
Current Swell Ph2	Current swell alarms for phase 2
Current Swell Ph3	Current swell alarms for phase 3

<sup>1</sup> Any Setpoint or Relative Setpoint module with an event priority greater than the Low alarm event priority is also displayed on this screen.

You can only enable or disable alarms using the display. Alarm configuration is done using ION Setup. Alarms with a priority less than **Low (Info Only or None)** are not displayed.

You must configure all the parameters related to the alarm for alarm functions to operate. For example, for the Over Ia alarm to operate, you must enter the nominal value and the conditions that define an alarm state, even if the alarm is shown as Enabled on the Alarm Setup screen.

## Configuring setpoint/standard alarms using ION Setup

You can use ION Setup to configure the standard alarm settings.

1. Start ION Setup.
2. Open the Setup Assistant for your meter.
3. Navigate to **Alarming** and click the **Standard** tab.
4. Select a setpoint and click **Edit**.
5. Enter unit password and click **OK**, if required.

The **Setpoint Setup** screen is displayed.

6. Configure the setpoint values as required.
7. Click **Save** to save the settings to your meter.

Parameter	Value/Range	Description
By Percentage	By Percentage/By Value	When available, specifies if the Pickup and Dropoff entries are by percentage or by value. If the option is not available, pickup and dropoff entries are by value.
Force Off	Checked/Unchecked	Forcing the alarm off disables all functions of the associated input. To stop an alarm from being displayed without affecting other meter features, set the alarm priority to Info Only.
Label	String value	When available, lets you modify the default label so it more clearly identifies the alarm. Letters, numbers, underscores are permitted. Spaces are not permitted.
Pickup	Numeric value	Use this setting to provide a value for when the alarm turns on.
Pickup Delay	Numeric value	This specifies the number of seconds the digital input must be in the alarm pickup state before the alarm turns on.
Dropout	Numeric value	Use this setting to provide a value for when the alarm turns off.
Dropout Delay	Numeric value	This specifies the number of seconds the digital input must be below the alarm dropout state before the alarm turns off.
Alarm Priority	None, Info Only, Low, Medium or High	Specifies the priority level of the standard alarm. To disable the alarm, set priority to Info Only.
Custom Priority	0-255	Select custom priority to view and configure the event priority of the event associated with the alarm. The event log cutoff value is displayed for reference; priorities above the cutoff are stored in the meter's event log.

## Configuring sag/swell alarms using ION Setup

You can use ION Setup to configure the sag/swell alarm settings.

1. Start ION Setup.
2. Open the Setup Assistant for your meter.
3. Navigate to **Alarming > Sag/Swell**.

4. Select the parameter you want to configure and click **Edit**.

The setup dialog box for that parameter appears.

5. Configure the parameters as required.

The values you need to set vary depending on the type of sag/swell alarm you are configuring.

### Voltage sag/swell setup parameters

Parameter	Value/Range	Description
Force Off	Selected (enabled) or Cleared (disabled)	Leave this checkbox cleared to enable voltage sag/swell alarms and associated sag/swell recording. Selecting Force Off disables the sag/swell alarm and any associated sag/swell recording.  To stop an alarm from being displayed without affecting other meter features, set the alarm priority to Info Only.
Nominal	1 to 999,999	Specifies the nominal voltage value used for sag/swell detection.
Swell Limit	Percentage of nominal	Specifies the swell limit expressed as a percentage of the nominal voltage.
Sag Limit	Percentage of nominal	Specifies the sag limit expressed as a percentage of the nominal voltage.
Hysteresis	Percentage – see description	Specifies the difference in magnitude between the sag or swell limit and the threshold for the power quality event to be considered over.  For example, if the meter has the sag limit set to 90% of nominal and the hysteresis is set to 2%, this means that in a sag event, the voltage needs to return to 92% of nominal for the sag event to be considered over
Alarm priority	See description	Select the alarm priority you want to associate with Sag/Swell alarms.

### Current sag/swell setup parameters

Parameter	Value/Range	Description
Force Off	Selected (enabled) or Cleared (disabled)	Leave this checkbox cleared to enable current sag or current swell alarms and associated sag/swell recording. Selecting Force Off disables the alarm and any associated sag/swell recording  To stop an alarm from being displayed without affecting other meter features, set the alarm priority to Info Only.
Nominal	1 to 999,999	Specifies the nominal current value used for current sag or current swell detection.
Pickup	Percentage of nominal	Specifies the percentage the current must deviate from the nominal current in order to be classified as a sag or a swell.
Dropout	Percentage of nominal	Specifies the percentage of nominal the current must recover to in order to signal the end of the sag or the swell.
Hysteresis	N/A	Displays the difference in magnitude between the sag or swell Pickup and Dropout values.  To change the hysteresis, change the Pickup or Dropout values.
Alarm priority	See description	Select the alarm priority you want to associate with Sag/Swell alarms.

### Related Topics

- Configuring sag/swell logging and waveform recording using ION Setup
- Implementing sag/swell limit learning using ION Setup

### Configuring digital input alarms using ION Setup

You can use ION Setup to configure the digital alarm settings.

1. Start ION Setup.

2. Open the Setup Assistant for your meter.
3. Navigate to **Alarming > Digital Input**.
4. Configure the digital input alarm settings by selecting an input and clicking **Edit**. Some settings are not configurable and are grayed out.
5. Click **Save** to save the changes to the meter.

Parameter	Value/Range	Description
Input	Input On/Input Off	Specifies the input state/alarm behavior: <ul style="list-style-type: none"> <li>• Input On: the alarm is on when the digital input is on.</li> <li>• Input Off: the alarm is on when the digital input is off.</li> </ul>
Force Off	Checked/Unchecked	Forcing the alarm off disables all functions of the associated input. To stop an alarm from being displayed without affecting digital input features, set the alarm priority to Info Only.
Label	String value	When available, lets you modify the default label so it more clearly identifies the alarm. Letters, numbers, and underscores are permitted. Spaces are not permitted.
Alarm Priority	None, Info Only, Low, Medium or High	Specifies the priority level of the digital input alarm. To disable the alarm, set priority to Info Only.
Custom Priority	0-255	Select custom priority to view and configure the event priority of the event associated with the alarm. The event log cutoff value is displayed for reference; event priorities above the cutoff are stored in the meter's event log.

## Alerting

An alert is an external notification produced by the meter to indicate changes, for example, a change of state for a digital input, or a power quality event such as a sag or swell.

Alerts are generated when a pulse or trigger that is configured to indicate the alert condition activates. You can configure alerts to send notification emails or messages to your energy management system through your meter's existing Ethernet communications connections. You can configure alert messages as a simple text string or you can also include device information. You can configure the alert's priority so that alerts are also recorded in the meter's event log.

You can configure multiple alerts on a single meter, each having different activation triggers, messages and/or transmission types. For instance, you can have two alerts, one generating an email, the other sending a message to your energy management system, but using the same trigger conditions; or you can have two alerts with different conditions that send two unique emails to two different email addresses. You can also generate alerts based on triggers from devices connected to your meter.

Creating alerts is an advanced feature that requires familiarity with ION architecture and your power system and communications network. To create an alert, you must configure the Alert module using a configuration tool. You must also configure your device's communications as needed to send the alerts, such as configuring your meter's SMTP settings and connecting it via Ethernet to an SMTP mail server in order to send an alert by email.

Go to [www.usa.siemens.com/pds](http://www.usa.siemens.com/pds) to see the *ION meter alerts* technical note for detailed information on creating and configuring alerts, and the *ION Reference* for detailed information about the Alert module and its operation.

## Setpoint learning overview

Your meter can learn acceptable ranges or thresholds by monitoring normal operating values to determine what constitutes a voltage sag or swell in order to help identify high and low setpoints.

**NOTE:** To help your meter learn the most accurate values possible, it is important that learning occur during a period of normal operation. Do not schedule learning during a period of unusual operations in your system. Do not modify your meter's configuration during the learning period as it may stop the learning process.

You can configure the meter so that learned values are applied automatically once the learning period is complete or require that they are reviewed and manually applied. If a learned value is invalid, the learned values are not automatically applied, but logged for review.

Setpoint learning can be used to identify the following values:

Feature	Values
Setpoints (Alarms)	High limit Low limit Sustain until ON Sustain until OFF
Sag	Voltage sag limit
Swell	Voltage swell limit

## Learning installation mode and learning duration

You can configure learning for manual or automatic mode.

There are two learning installation modes:

- **Manual:** the meter learns the applicable values but does not begin using the learned values. The learned values are recorded for review, and you can decide to use the learned values or adjust them as required before manually implementing the learned values.
- **Automatic:** the meter learns the applicable values and begins using those learned values automatically at the end of the learning period. If a learned value is invalid, the meter does not apply the value, but the value is recorded in the event log.

You can configure the maximum learning duration. The actual learning duration may vary, depending on the stability of the system. If the system is stable for a period equal to one quarter of the maximum learning duration, learning is complete; otherwise, the learning period will be the maximum learning duration.

### Example: Setpoint learning duration in a stable system

In this example, the learning duration is 30 days. When the system is stable for 7.5 days (one quarter of 30 days) learning is complete.

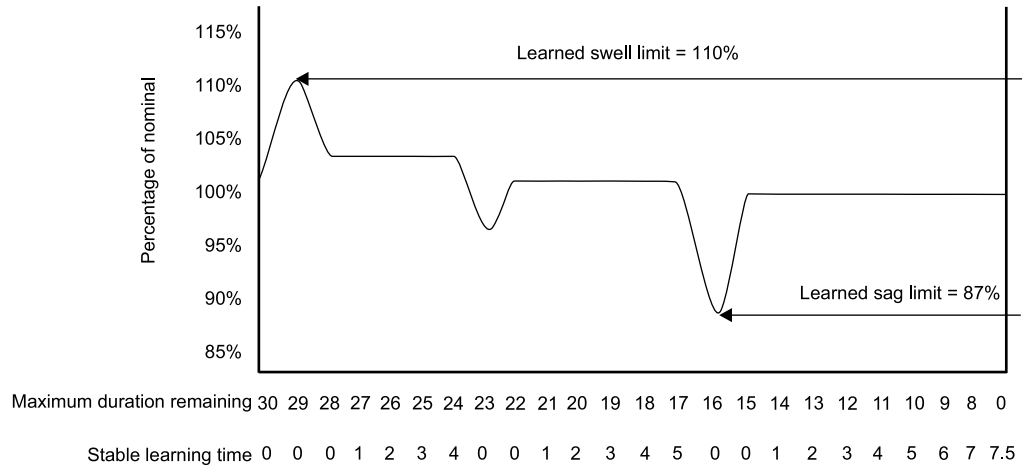

### Example: Setpoint learning duration in an unstable system

In this example, the learning duration is 30 days. Because the system is not stable for 7.5 days (one quarter of the 30 days) learning is complete at the end of the maximum learning duration.

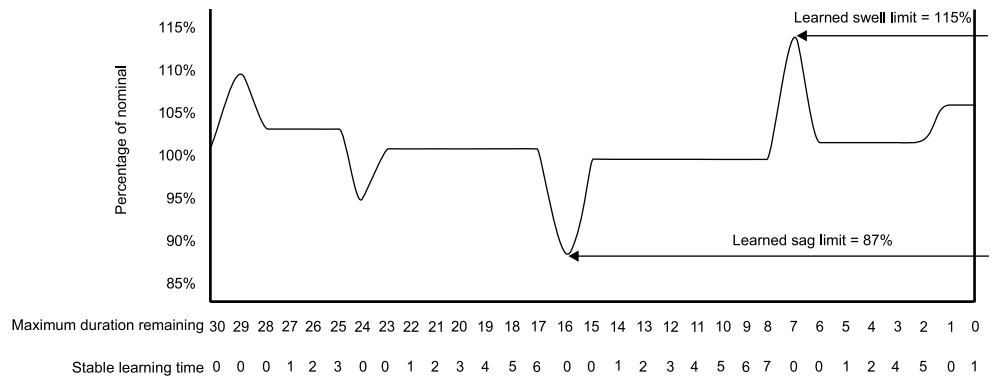

See the ION Reference, available from [www.usa.siemens.com/pds](http://www.usa.siemens.com/pds), for more information on Sag/Swell, Setpoint and Relative Setpoint modules.

## Implementing standard alarm setpoint learning using ION Setup

You can use ION Setup to implement setpoint learning, which analyzes your power system and recommends settings.

**NOTE:** Your meter's power system must be stable in order to learn valid setpoint values.

1. Start ION Setup.
2. Open the Setup Assistant for your meter.
3. Navigate to **Alarming > Standard**.

**NOTE:** You can manually configure setpoint values by selecting the setpoint and clicking **Edit**.

4. Select a setpoint and click **Learn**.

The **Global Setpoint Learning** screen is displayed.

5. Select the setpoint tabs to view existing configured or learned setpoint information.

6. Click **Setup**.  
The **Alarm Learning Setup** screen is displayed.
7. Configure the learning parameters for each setpoint and click **Save**.
8. Click **Start All** to begin setpoint learning for all setpoints.
  - When setpoint learning is in progress, an asterisk is displayed next to the setpoint.
  - Click **Abort** to stop learning for a specific setpoint. To stop all setpoint learning, repeat for each setpoint tab.
9. Apply the learned setpoint values:
  - Automatic: the setpoint values are automatically applied unless the learning process has issues or the learned values are invalid.
  - Manual: navigate to **Alarming > Setpoints** and click **Learn**. On each setpoint tab, click **Install** to apply the learned values to that setpoint.

**NOTE:** If you click **Install** while learning is in progress (in either manual or automatic installation mode), it stops the learning process and prompts you for confirmation that you want to stop learning and install the learned values. Once you confirm, the learned values are automatically installed or prepared for manual installation.

#### Setpoint learning parameters

Parameter	Value/Range	Description
Install mode	Automatic, Manual	<ul style="list-style-type: none"> <li>• Automatic: the learned values are automatically applied.</li> <li>• Manual: the learned values are stored for you to review and enter.</li> </ul>
Duration	1-365	Days for maximum learning duration.

## Implementing sag/swell limit learning using ION Setup

You can use ION Setup to implement voltage sag/swell learning, which analyzes your power system and recommends settings.

**NOTE:** Your meter's power system must be stable in order to learn valid sag/swell limits.

1. Start ION Setup.
2. Open the Setup Assistant for your meter.
3. Navigate to **Alarming > Sag/Swell**.
4. Select **Voltage** and click **Learn**.
 

**NOTE:** You can manually configure the limit values by selecting the parameter and clicking **Edit**.

The **Global Setpoint Learning** screen is displayed.
5. Click **Setup**.  
The **Alarm Learning Setup** screen is displayed.
6. Configure the sag/swell limit learning parameters and click **Save**.

7. Click **Start** to begin sag/swell limit learning.
  - When setpoint learning is in progress, an asterisk is displayed next to the setpoint.
  - Click **Abort** to stop sag/swell limit learning.
8. Apply the learned sag/swell limits.
  - Automatic: the limits are automatically applied unless there are issues with the learning process.
  - Manual: navigate to **Alarming > Sag/Swell**. Select **Voltage** and click **Learn**. Click **Install** to apply the learned limits.

**NOTE:** If you click **Install** while learning is in progress (in either manual or automatic installation mode), it stops the learning process and prompts you for confirmation that you want to stop learning and install the learned limits. Once you have confirmed, the learned limits are automatically installed or prepared for manual installation.

#### Sag/swell limit learning parameters

Parameter	Value/Range	Description
Install mode	Automatic, Manual	<ul style="list-style-type: none"> <li>• Automatic: the learned values are automatically applied.</li> <li>• Manual: the learned values are stored for you to review and enter.</li> </ul>
Duration	1-365	Days for maximum learning duration.

# Resets

## Meter resets

Resets allow you to clear various accumulated parameters stored on your meter or reinitialize the meter or meter accessories.

Meter resets clear your meter's onboard data logs and other related information. Resets are typically performed after you make changes to the meter's basic setup parameters (such as frequency, VT/PT or CT settings) to clear invalid or obsolete data in preparation for putting the meter into active service.

## Option module reset

Perform an option module reset if your option modules are not communicating to your meter.

During an option module reset, your option module may not operate normally, and digital and analog outputs may change state.

### **⚠ WARNING**

#### **UNINTENDED OPERATION**

**Failure to follow these instructions can result in death, serious injury or equipment damage.**

Do not use the meter for critical control or protection applications where human or equipment safety relies on the operation of the control circuit.

You can reset your meter's option module bus through the display or using ION Setup. This power cycles all the modules attached to your meter. If you have queued firmware updates for your option modules on your meter's internal FTP site, the firmware updates are performed. Your option modules do not operate normally during an option module reset.

By default, your meter is configured so that your meter automatically performs an option bus reset when needed to help keep the option modules operating normally. Contact Technical Support for instructions on changing this default configuration.

## Available resets

You can perform various meter resets through the meter's display or ION Setup.

Reset	Description
Master Reset	<ul style="list-style-type: none"> <li>Clears all the cumulative and derived quantities from the meter (including demand, peak demand, energy and revenue parameters).</li> <li>Clears meter event and waveform logs.</li> <li>Clears COMTRADE waveform records from the meter's internal FTP server.</li> <li>Clears the meter's data logs.</li> </ul>
Peak Demand Reset	Clears the peak demand values logged in the meter. <b>NOTE:</b> The peak demand reset has a lockout period that sets the minimum time allowed between consecutive resets.
Min/Max Reset	Clears all accumulated maximum and minimum values stored in the meter.
Digital Input Count Reset	Clears the digital input status change counters.

Reset	Description
Harmonics Min/Max Reset	Clears all accumulated maximum and minimum harmonics values stored in the meter.
Disturbance Count Reset	Clears the sag/swell event counter. The sag/swell event counter counts the number of sag/swells that have occurred since power-up or the last reset, to provide power quality information to energy management systems.
EN50160 Reset	Clears all EN50160 parameters and statistics accumulated in the meter.
Option modules reset	Resets communications to the meter's expansion modules.
Conditional energy reset	Clears the conditional energy values stored in the meter.
Input metering reset	Clears the input metering values stored in the meter.

## Related Topics

- Peak demand

## Performing meter resets using the display

You can perform meter resets from the display after entering a valid password.

Revenue-locked meters must be unlocked to perform resets that impact revenue data.

Your meter's digital and analog outputs may change state or may not function during resets.

### **▲ WARNING**

#### **HAZARD OF UNINTENDED OPERATION**

**Failure to follow these instructions can result in death, serious injury or equipment damage.**

Do not use the meter for critical control or protection applications where human or equipment safety relies on the operation of the control circuit.

Meter resets clear the meter's onboard data logs and other related information.

### **NOTICE**

#### **DATA LOSS**

**Failure to follow these instructions can result in data loss.**

Ensure all important data from the device has been retrieved before performing a reset.

1. Navigate to **Setup Menu > Resets**.  
Enter your login credentials, if requested.
2. Press the edit button to access the configuration menu and use the up and down buttons to navigate through.
3. Press the up and down buttons simultaneously to select the resets you want to perform
4. Press the select button to perform the resets.

When you select **Master Reset**, the message ALL RECORDED DATA WILL BE LOST. RESET SELECTED PARAMETERS? is displayed. Press the select button to confirm the master reset.

## Related Topics

- Revenue locking

## Resets

You can perform meter resets using the display.

Parameter	Description
Master Reset	<ul style="list-style-type: none"> <li>• Clears all the cumulative and derived quantities from the meter (including demand, peak demand, energy, revenue and test mode parameters)</li> <li>• Clears meter event and waveform logs</li> <li>• Clears COMTRADE waveform records from the meter's internal FTP server</li> <li>• Clears the meter's data logs</li> </ul>
Peak Demand Reset	Clears the peak demand values logged in the meter
Min/Max Reset	Clears all accumulated maximum and minimum values stored in the meter
Digital Input Count Reset	Clears the digital input state change counters
Harmonics Min/Max Reset	Clears all accumulated maximum and minimum harmonics values stored in the meter
Disturbance Count Reset	Clears the sag/swell event counter
EN50160 Reset	Clears all EN50160 parameters and statistics accumulated in the meter
Option Modules Reset	Restarts all option modules attached to the meter

## Performing meter resets using ION Setup

You can perform meter resets on your meter using ION Setup.

Revenue-locked meters must be unlocked to perform resets that impact revenue data.

Meter resets clear the meter's onboard data logs and other related information.

### **NOTICE**

#### **DATA LOSS**

**Failure to follow these instructions can result in data loss.**

Ensure all important data from the device has been retrieved before performing a reset.

1. Open the Setup Assistant for your meter.
2. Select the **Verification** screen.
3. Select **Normal Mode** and click **Display**.

4. Select the desired tab in the **Normal Mode** dialog box. Depending on the tab selected, different resets are available.

Tab	Reset available
Energy	Master Reset
Rolling Demand	Peak Reset Master Reset
Volts, Amps and Power	Master Reset
Conditional Energy	Cnd Reset Master Reset
Input Metering	IM(n) Reset <b>NOTE:</b> n is the input metering number, for example IM1. Peak Reset Master Reset

5. Click the appropriate button to perform the reset.

For some resets, the meter indicates that the reset is in progress. Do not configure or power down your meter until it indicates that the reset is complete or some parameters may not be completely reset.

### Related Topics

- Revenue locking

# Measurements

## Power and power factor

The sampled measurements taken at the meter's voltage and current inputs provide data for calculating power and power factor.

In a balanced 3-phase alternating current (AC) power system source, the AC voltage waveforms on the current-carrying conductors are equal but offset by one-third of a period (a phase angle shift of 120 degrees between the three voltage waveforms).

## Power factor (PF)

Power factor (PF) is the ratio of real power (P) to apparent power (S).

Power factor is provided as a number between -1 and 1 or as a percentage from -100% to 100%, where the sign is determined by the convention.

$$PF = \frac{P}{S}$$

An ideal, purely resistive load has no reactive components, so its power factor is one (PF = 1, or unity power factor). Inductive or capacitive loads introduce a reactive power (Q) component to the circuit which causes the PF to become closer to zero.

## True PF and displacement PF

The meter supports true power factor and displacement power factor values:

- True power factor includes harmonic content.
- Displacement power factor only considers the fundamental frequency.

**NOTE:** Unless specified, the power factor displayed by the meter is true power factor.

## Apparent, active and reactive power (PQS)

Apparent power (S) is the capacity of your measured power system to provide active (real power, P) and reactive power (Q).

A typical AC electrical system load has both resistive and reactive (inductive or capacitive) components. Resistive loads consume real power (P). Reactive power (Q) is either consumed (inductive loads) or generated (capacitive loads).

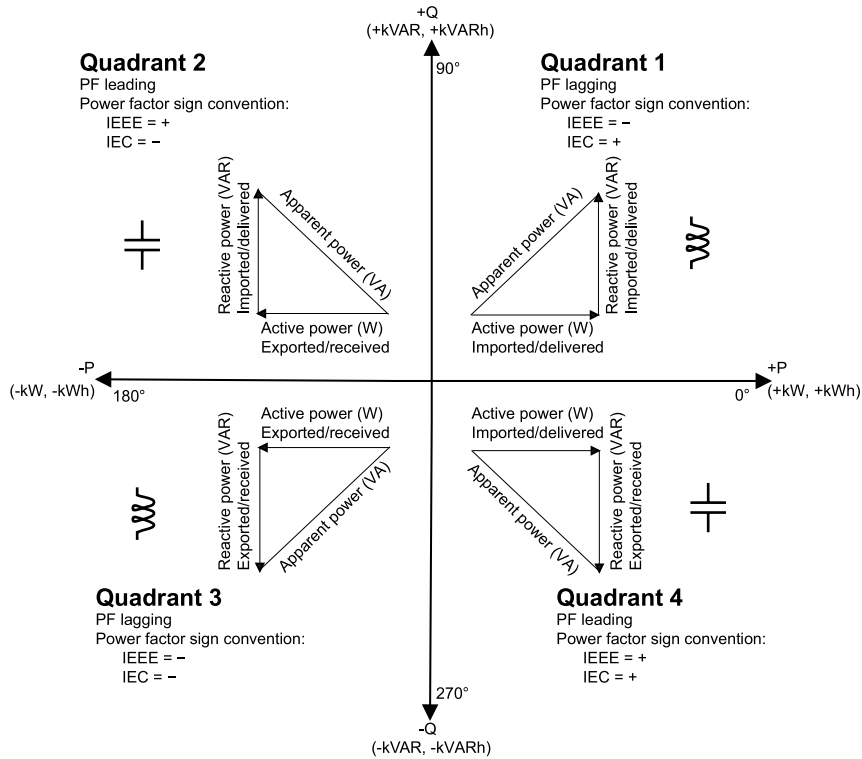

The units for power are watts (W or kW) for real power P, vars (VAR or kVAR) for reactive power Q, and volt-amps (VA or kVA) for apparent power S.

Positive real power P(+) flows from source to load, and negative real power P(-) flows from the load to the power source.

## Current phase shift from voltage

Electrical current can lag, lead, or be in phase with the AC voltage waveform, and is typically associated with the type of load — inductive, capacitive or resistive.

For purely resistive loads, the current waveform is in phase with the voltage waveform. For capacitive loads, current leads voltage. For inductive loads, current lags voltage.

The following diagrams show how voltage and current waveforms shift based on load type under ideal (laboratory) conditions.

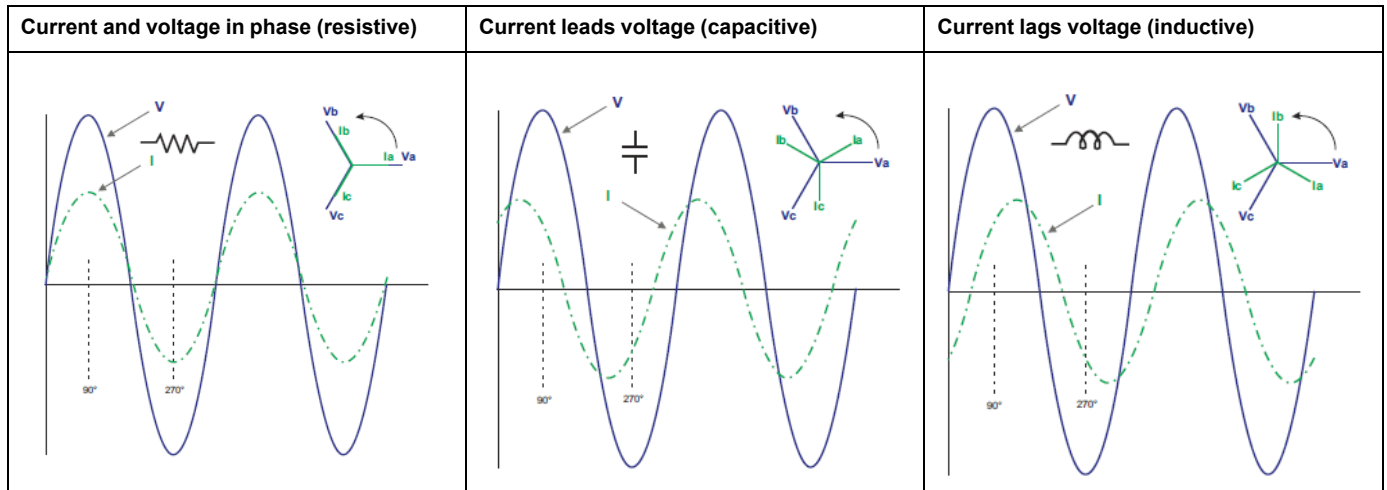

## Power demand

Power demand is a measure of average power consumption over a fixed time interval.

**NOTE:** If not specified, references to “demand” are assumed to mean “power demand.”

The meter measures instantaneous consumption and can calculate demand using various methods.

## Peak demand

Peak (or maximum) demand is the highest demand level recorded over the billing period.

Power utilities generally bill commercial customers based on their peak usage levels, called peak demand (in kW) and energy consumption (in kWh). Peak (or maximum) demand is the highest demand level recorded over the billing period. You can view peak demand values on your meter’s display.

Your meter calculates the average current demand and kW, kVAR and kVA demand using sliding window demand methods. The meter supports coincident demand values when a peak demand is detected.

Your meter’s default configuration is suitable for most applications, or you can customize it for your specific application. You can configure the minimum time between consecutive demand resets.

**NOTE:** If not specified, references to “demand” are assumed to mean “power demand”.

## Peak demand reset lockout

The demand reset lockout time sets the minimum time allowed between consecutive demand resets; the meter ignores any attempts to reset demand that occur within the lockout period.

The peak demand reset lockout period is user-configurable, with a default value of 25 days.

See the ION Setup online help for instructions on how to configure demand peak and the demand reset lockout period on your meter.

See the ION Reference, available from [www.usa.siemens.com/pds](http://www.usa.siemens.com/pds), for detailed information on how Sliding Window Demand modules measure and calculate demand values.

### Related Topics

- Meter resets
- Data viewing using your meter’s display

## Sliding window demand

To calculate demand values, your meter uses the sliding window averaging (or rolling interval) method which divides the demand interval into a set number of subintervals of specified duration.

The demand is measured electronically based on the average load level over the most recent set of subintervals. Sliding window demand also provides predicted demand values.

## Examples of sliding window demand

This example shows two different ways of configuring a 15-minute demand interval:

- Single interval (also called block or timed block): the 15-minute demand interval is defined as a single subinterval with a duration of 15 minutes.
- Sliding window (also called rolling block): the 15-minute demand interval is defined as three subintervals with a duration of 5 minutes each. This method offers better response time than a single interval.

### Single interval (block)

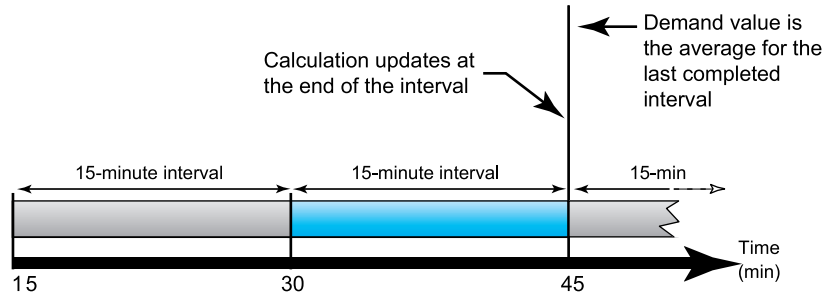

### Sliding window (rolling block)

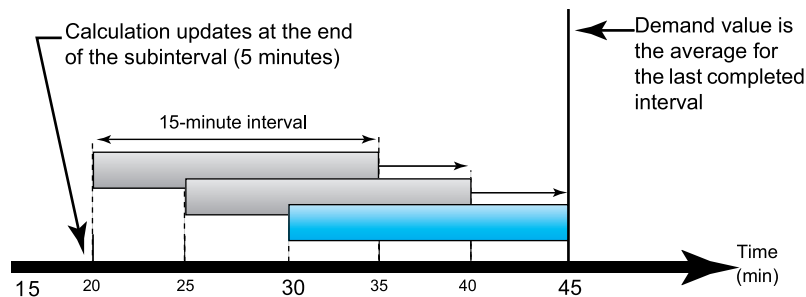

## WAGES monitoring

WAGES monitoring allows you to record and analyze all energy sources and utilities usage.

Your energy system may use several different types of energy. For example, you may consume steam or compressed air for industrial processes, electricity for lights and computers, water for cooling and natural gas for heating. WAGES monitoring collects the usage information from all these different energy sources to enable a more complete energy analysis.

WAGES information can help you:

- Identify losses or inefficiencies.
- Modify demand to reduce costs.
- Optimize energy source usage.

### WAGES example

This example shows WAGES monitoring for a water flow meter.

You can connect your meter's digital input to a transducer that sends a pulse for every 15 kiloliters (4000 US Gal) of water. After configuring an input metering channel and assigning it to the digital input, the meter is able to detect and record the incoming

pulses. An energy management system can then use the information from the meter to perform WAGES analysis.

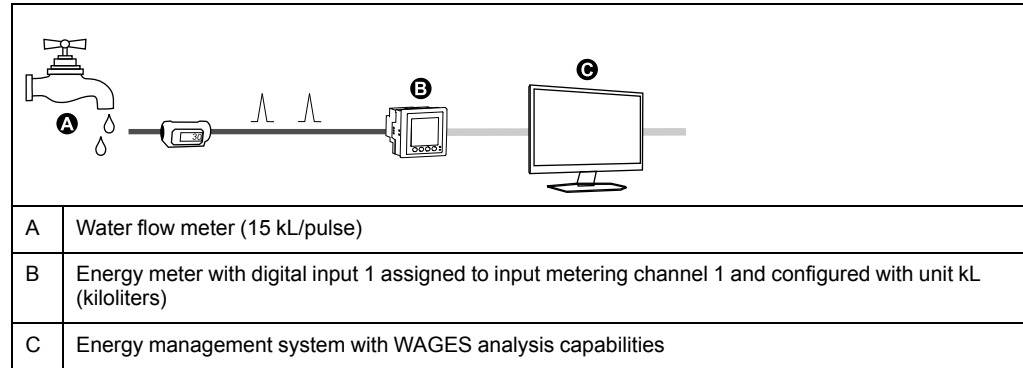

## Incremental energy

Incremental energy allows you to define a start time, end time, and the time interval (increments) for incremental energy accumulation.

At the end of each interval, the energy accumulated during that period is stored. By default, the meter only records the previous interval's incremental energy and the instantaneous energy accumulations in the active interval.

The first interval of incremental energy accumulation begins at the specified start time. Incremental energy ends at the specified end time, which may result in a truncated interval if the interval duration does not divide evenly into the overall incremental energy duration (for example, an interval duration of three hours with an overall duration of five hours truncates the last interval duration to two hours). The latest value for the specified end time is midnight (24:00).

Your start time must be before the end time and after midnight, and the period over which incremental energy is accumulated cannot include midnight. This is because your meter's start and end times are defined relative to midnight.

Start: 6 am, End: 12 am, interval: 3 hrs	Incremental energy accumulates from 6 am to midnight in intervals of 3 hours.
Start: 6 am, End: 2 am, interval: 3 hrs	Incremental energy will not function. End time must be after start time and before or equal to midnight.

Incremental energy helps provide information for analyzing energy and power usage against present or future utility rates, and is useful for comparing different time-of-use rate structures.

When configuring incremental energy, shorter incremental energy periods provide more granular data which can make the data easier to use for comparison purposes.

## Incremental energy example

- Start time: 8 am or 08:00
- End time: 12 am or 24:00
- Interval: 420 minutes (7 hours)

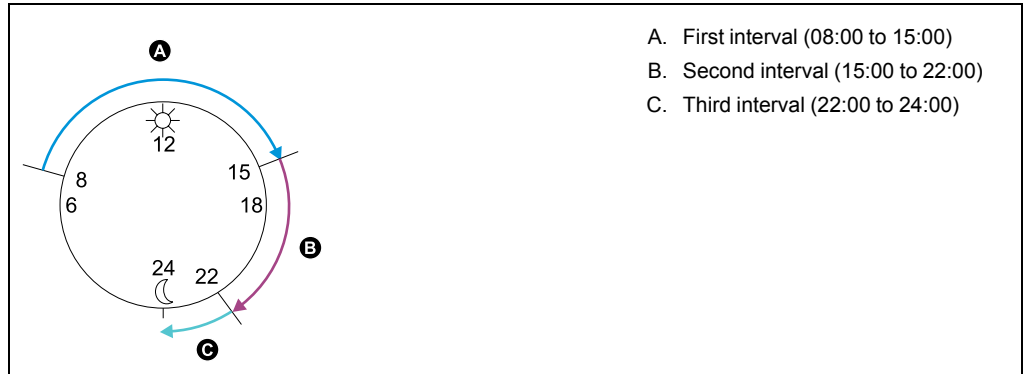

The first incremental energy interval is from 8 am (start time) to 3 pm, and is seven hours long. The second incremental energy interval is from 3 pm to 10 pm, and is also seven hours long. The third interval is from 10 pm to 12 am, and is only 2 hours long because 12 am is the specified end time. These intervals repeat every 24 hours until the configuration is changed or incremental energy feature is disabled.

## Configuring incremental energy using ION Setup

You can configure incremental energy using ION Setup.

1. Start ION Setup.
2. Open the Setup Assistant for your meter.
3. Navigate to **Energy Applications > Incremental Energy**.
4. Select **Status** and click **Edit**. The incremental energy configuration screen is displayed.

**NOTE:** To display parameters for configuration, select **Enable**.

5. Select the parameter to configure and click **Edit**. Your changes are made to the meter.

**NOTE:** Configuring any parameter resets the incremental energy values recorded by your meter.

Parameter	Range	Description
Status	Enable/disable	Enables the incremental energy feature.
Start time	12:00 am to 11:59 pm	The incremental energy first interval's start time. The start time must be prior to the end time for energy accumulation.
End time	12:01 am to 12:00 am	The end time for incremental energy.  The end time must be after the start time and be less than or equal to 12 am (midnight).
Interval duration	Configurable	The increment period for the incremental energy duration.

## Conditional energy

Conditional energy allows you to define an accumulation period for real and reactive energy using one of your meter's digital inputs.

You can use conditional energy to track four-quadrant accumulated energy during a specific period; for example you may want to track accumulated energy values during a particular process controlled using a programmable logic controller (PLC).

Conditional energy is accumulated until it is reset. The conditional energy reset date and time information is stored in the meter's event log.

### Related Topics

- Apparent, active and reactive power (PQS)

## Configuring conditional energy using ION Setup

You can enable and configure conditional energy settings using ION Setup.

When configuring your meter, the configuration interface may show all of the possible ports, regardless of what is physically available on your meter.

One of your device's digital inputs must be connected and configured to define when conditional energy is accumulated.

1. Start ION Setup.
2. Open the Setup Assistant for your meter.
3. Navigate to **Energy Applications > Digital Input Based**. Review the digital inputs assigned to applications to help ensure there are no conflicting usages.
4. Select **Conditional Energy** and click **Edit**. The **Conditional Energy Setup** screen is displayed.
5. Select **Enabled** to enable the conditional energy feature.
6. Click **Select** to define the digital input. The input's state determines whether conditional energy is accumulated. When this digital input is on, conditional energy is accumulated.

**NOTE:** It is recommended to set **Assigned Input** to No Connection to disable the conditional energy feature by removing any port associations.

7. Click **OK** to save your configuration.

## Trending and forecasting overview

Trending and forecasting is a feature on your device that predicts the next set of measured or calculated data by plotting and analyzing trends in historical data.

Trending and forecasting data is a useful tool to help analyze changes in load and power quality and forecasting values such as demand. For your meter's trending and forecasting feature to work, you only need to give the meter time to accumulate data.

## Trending and forecasting implementation

Data used for trending and forecasting can be logged for specific intervals.

Data used is logged for the following intervals:

- Every hour for the last 24 hours
- Every day for the last month
- Every week for the last 8 weeks
- Every month for the last 12 months

The following parameters are configured for trending and forecasting using ION Setup:

kW sd del-rec (demand)	Freq (frequency)
VII ab	I a mean
VII bc	I b mean
VII ca	I c mean
VII avg	I avg mean

You can configure the start day of the week for trending and forecasting using ION Setup.

## Viewing trending and forecasting data on your meter's webpages

You can select data for forecasting and trending and view the resulting information using your meter's webpages.

For trending and forecasting to operate, your meter must have accumulated data for at least two of the specified intervals; for example, if you want to view a daily graph, your meter must have accumulated data for at least two previous days before the present day.

1. Log in to your meter's webpages
2. Click **Monitoring > Trending & Forecasting**
3. Select the **Target** and **Interval**. The graph for the selected data is displayed.

# Power quality

## Power quality overview

Your meter measures voltage and current harmonics, and calculates several harmonic distortion values as well as K-factor and crest factor values.

You must configure your meter with nominal values for voltage, current and frequency for the power system being monitored in order for the meter to perform power quality calculations. Your meter also creates a phasor diagram, including numeric values for magnitude and angle, to represent your power system.

## Sag/swell overview

Your meter monitors your power system's voltage and current for sags and swells (INCITS (CBEMA) Type 2 and Type 3 disturbances); it then reports the disturbance's magnitude and duration.

You can manually enter the limits (criteria) used by the meter to identify a sag or swell, or you can have your meter learn sag/swell limits by monitoring your power system.

### Related Topics

- Configuring sag/swell logging and waveform recording using ION Setup
- Setpoint learning overview
- Waveform recording overview
- Disturbance (sag/swell) alarms

## Harmonics overview

Harmonics information is valuable for power quality analysis, determining properly rated transformers, maintenance and troubleshooting.

Harmonics are integer multiples of the fundamental frequency of the power system. Harmonics information is required for compliance to system power quality standards such as EN50160 and meter power quality standards such as IEC 61000-4-30.

Harmonics measurements include per-phase magnitudes and angles (relative to the fundamental frequency of the phase A voltage) for the fundamental and higher harmonics relative to the fundamental frequency. The meter's power system setting defines which phases are present and determines how line-to-line or line-to-neutral voltage harmonics and current harmonics are calculated.

Harmonics are used to identify whether the supplied system power meets required power quality standards, or if non-linear loads are affecting your power system. Power system harmonics can cause current flow on the neutral conductor, and damage to equipment such as increased heating in electric motors. Power conditioners or harmonic filters can be used to minimize unwanted harmonics.

## Viewing harmonics information using the display

You can view detailed harmonics data through your meter's display.

1. Navigate to **Power Quality > Harmonics**. The total harmonic distortion (THD) screens are displayed.
2. Press the more button, and select the desired harmonics. The per-phase harmonics are graphically displayed.
3. Press the left and right buttons to move to individual harmonics. The harmonic number, magnitude and angle are displayed.

### Related Topics

- Data viewing using your meter's display

## Voltage crest factor

Crest factor is the ratio of peak to RMS voltage values.

For a pure sinusoidal waveform, crest factor is equal to 1.414. The meter uses the following equation to calculate crest factor:

$C = \frac{V_{\text{peak}}}{V_{\text{RMS}}}$	C = Crest factor
	$V_{\text{peak}}$ = Voltage peak
	$V_{\text{RMS}}$ = Voltage RMS

## Crest factor current

Crest factor is the ratio of peak to RMS current values.

For a pure sinusoidal waveform, crest factor is equal to 1.414. The meter uses the following equation to calculate crest factor:

$\text{Crest factor} = \frac{I_{\text{peak}}}{I_{\text{RMS}}}$	C = Crest factor
	$I_{\text{peak}}$ = Current peak
	$I_{\text{RMS}}$ = Current RMS

## K-factor

K-factor relates the heating effect of a distorted current in a transformer to a sinusoidal current with the same RMS magnitude — it describes a transformer's ability to serve non-linear loads without exceeding rated temperature rise limits.

The K-factor is equal to the sum of the squares of the harmonic currents multiplied by the squares of the harmonic order. The meter uses the following equation to calculate K-factor:

$$K = \frac{\sum_{n=1}^h (I_n^2 \times n^2)}{\sum_{n=1}^h I_n^2}$$

Where  $K$  is the K-factor,  $n$  is the harmonic order and  $I_n$  is the true RMS current of harmonic order  $n$ .

## Harmonic content calculations

Harmonic content ( $H_C$ ) is equal to the RMS value of all the non-fundamental harmonic components in one phase of the power system.

The meter uses the following equation to calculate  $H_C$ :

$$H_C = \sqrt{(H_2)^2 + (H_3)^2 + (H_4)^2 \dots}$$

## TDD calculations

TDD (total demand distortion) evaluates the harmonic currents between an end user and a power source.

The harmonic values are based on a point of common coupling (PCC), which is a common point where each user receives power from the power source.

The meter uses the following equation to calculate TDD:

$$TDD = (\sqrt{(HCIA)^2 + (HCIB)^2 + (HCIC)^2}) / (I_{Load}) \times 100$$

Where  $I_{Load}$  is equal to the maximum demand load on the power system.

## thd and TDD

Your meter can be configured to provide thd (total harmonic distortion using the total RMS value for the content rather than the fundamental content) and TDD (total demand distortion, the harmonic current distortion against the maximum demand of the electrical system).

$$thd = H_C / RMS * 100\%$$

$$TDD = H_C / Demand_{Max} * 100\%$$

This is an advanced procedure that should only be performed by users with an advanced knowledge of power quality, ION architecture, and the power system being monitored.

See the ION Reference, available from [www.usa.siemens.com/pds](http://www.usa.siemens.com/pds), for details about the Harmonics Measurement module.

## Phasors

Phasors are used to represent the voltage and current relative magnitude and angles.

The length of the lines in the phasor diagram represent the relative magnitude of the voltages with respect to the other phase voltages, and the currents with respect to the other phase currents. All angles are measured with respect to the  $V_a/V_1$  phase. The  $V_a/V_1$  phasor is fixed to the right-hand horizontal axis (positive x-axis). Positive angles are measured counterclockwise.

Numeric values are provided for the magnitude and relative angle for each voltage and current phase.

Phasor information can be used to troubleshoot incorrect connections on the meter's voltage and current inputs (for example, switched phase wiring or polarity errors), if you know how the phasors should be oriented for your power system.

# Disturbance direction detection overview

Your meter has disturbance direction detection capabilities to help you determine the location of a power system disturbance.

When a disturbance occurs, the meter analyzes the disturbance information to determine the direction of the disturbance relative to the meter. This analysis includes a confidence level indicating the level of certainty that the disturbance is in the determined direction, and is stored in your meter's event log.

Disturbance direction detection is enabled on your meter by default and does not require any additional configuration beyond setting the nominal voltage and nominal frequency.

Disturbance direction detection can help locate the source of a disturbance when used in a system of disturbance direction detection devices, as shown in the diagram below.

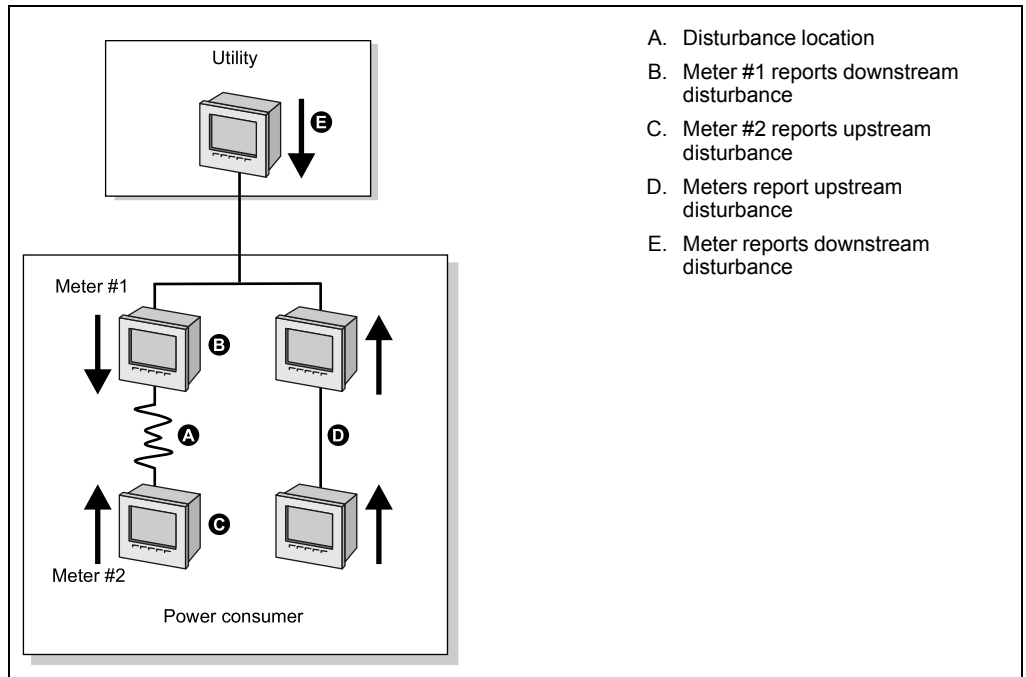

- A. Disturbance location
- B. Meter #1 reports downstream disturbance
- C. Meter #2 reports upstream disturbance
- D. Meters report upstream disturbance
- E. Meter reports downstream disturbance

The arrows show the direction the meters have determined for the disturbance. With this information, you can determine that the disturbance occurred between meter #1 and meter #2, and can focus on that section of your system to find the cause of the disturbance.

## Disturbance direction detection events information

The results of the disturbance direction detection algorithm appear in the meter's event log.

The image below shows an example of how the Disturbance Direction Detection event appears in your meter's event log when viewed using ION Setup.

**NOTE:** You can view your meter's event log through the display and ION Setup.

Date/Time	Cause	Value	Effect	Value
10/22/2007 2:29:11.918 PM	Sag/Swell 1	Disturbance End	SS1 DistState	Normal
10/22/2007 2:29:10.702 PM	Dist Direction Detection 1	DDD Analysis Done	Dist Direction Detection 1	Disturbance Direction Detected - Upstream - High Confidence
10/22/2007 2:29:10.702 PM	Sag/Swell 1	Disturbance Start	SS1 DistState	Disturbance

See the ION Reference, available from [www.usa.siemens.com/pds](http://www.usa.siemens.com/pds), for more detailed information about the Disturbance Direction Detection module.

### Related Topics

- Event log overview

## COMTRADE

Your meter can generate COMTRADE files and store them on the meter's internal FTP site.

COMTRADE stands for COMMon format for TRAnsient Data Exchange defined by IEC 60255-24 edition 2001-05, and defines a common format for power quality event (disturbance) data in order to simplify retrieval, analysis and exchange of disturbance data between multiple sources and vendors.

The format of your meter's COMTRADE files is as defined by IEC 60255-24 edition 2001-05.

COMTRADE can be used in conjunction with IEC 61850.

See the *COMTRADE and ION technology* technical note, available from [www.usa.siemens.com/pds](http://www.usa.siemens.com/pds), for detailed information about COMTRADE file formats and implementation.

### Related Topics

- FTP

## COMTRADE implementation overview

COMTRADE is configured as part of the default waveform recording framework.

COMTRADE records will be for sag/swell events. The only configuration you need to do is to enter your nominal voltage to enable waveform recording. COMTRADE records are stored as read-only files on your meter's internal FTP server, and are deleted when you perform a Master reset of the meter.

By default:

- The meter is configured so COMTRADE records are generated for the default waveform recorders.

**NOTE:** If you add additional waveform recorders and you want COMTRADE files generated for these new recorders, you need to configure a new COMTRADE module using ION Setup Advanced mode. You can configure up to three COMTRADE modules.

- The oldest COMTRADE record is overwritten by the newest record when the COMTRADE depth is exceeded.

**NOTE:** COMTRADE files can only be downloaded using an Ethernet connection. They cannot be downloaded using serial, modem or Ethernet gateway connections.

See the *COMTRADE and ION technology* technical note, available from [www.usa.siemens.com/pds](http://www.usa.siemens.com/pds), for detailed information about COMTRADE file formats and implementation.

## Related Topics

- Configuring sag/swell logging and waveform recording using ION Setup

## Waveforms on your meter's webpages

You can use the waveform viewer on the meter's webpages to view waveforms generated as a result of power quality events.

### Overview of how to setup and view waveforms on your meter's webpages

Before you can view waveforms on the meter's webpages, you need to perform some basic configuration to enable waveform capture and store the waveforms in COMTRADE format.

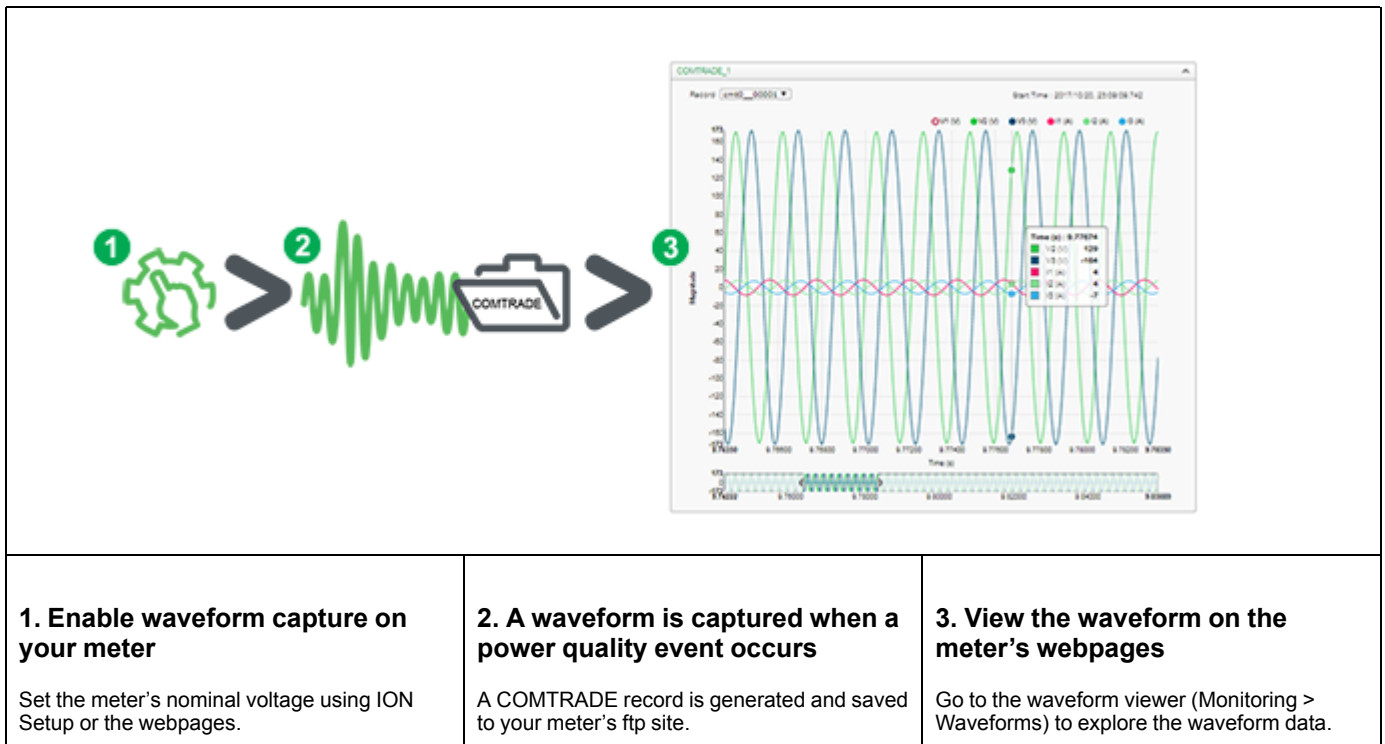

The waveform viewer uses the meter's COMTRADE files to display the waveforms. If the events you want to capture are not included in the default framework, you can customize the meter's waveform recording framework.

### Overview of the webpage waveform viewer

After COMTRADE files are generated by your meter, you can view them using the waveform viewer.

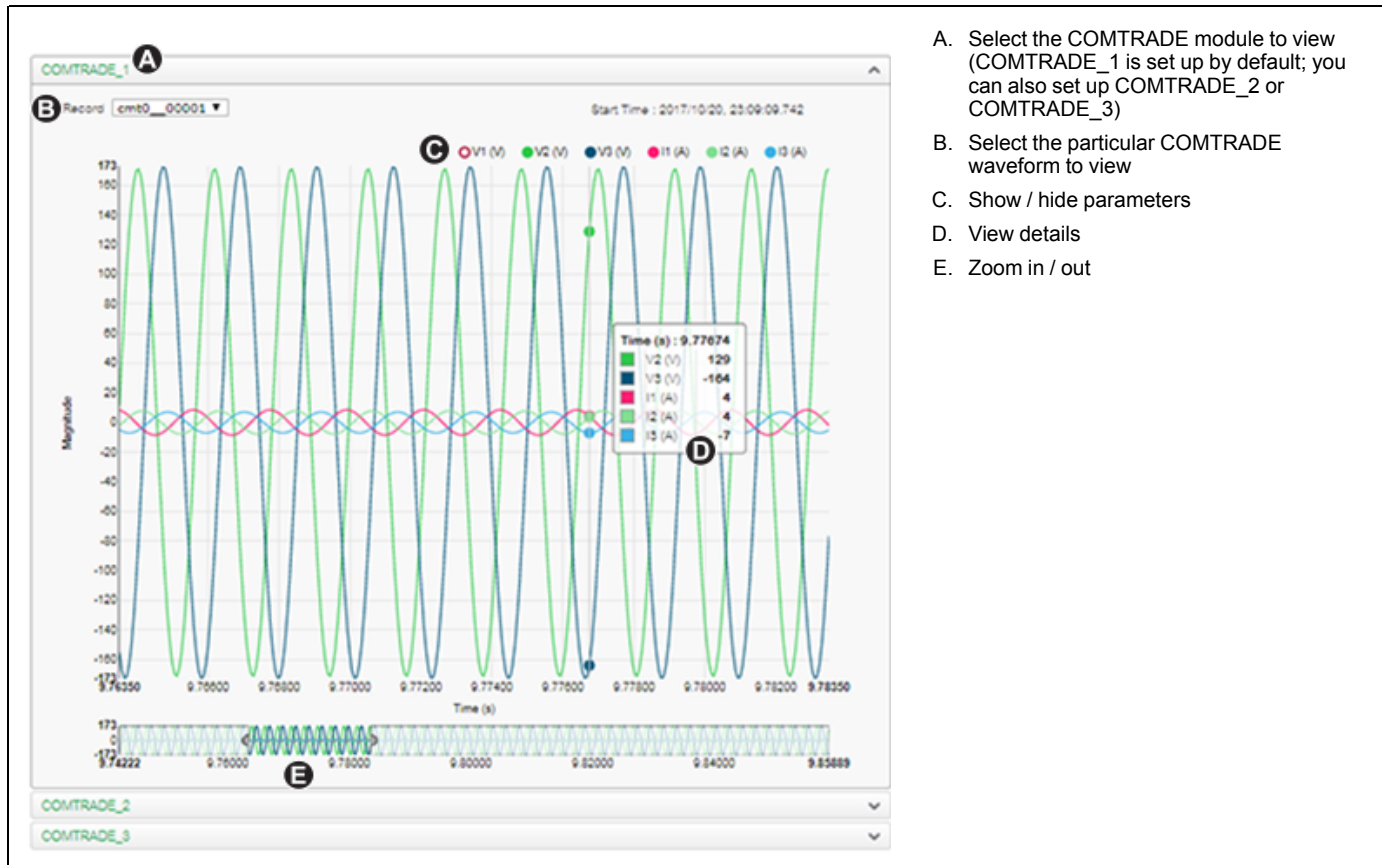

- A. Select the COMTRADE module to view (COMTRADE\_1 is set up by default; you can also set up COMTRADE\_2 or COMTRADE\_3)
- B. Select the particular COMTRADE waveform to view
- C. Show / hide parameters
- D. View details
- E. Zoom in / out

## Related Topics

- Default meter webpages

## Viewing waveforms on your meter's webpages

Use the waveform viewer on your meter's webpages to view the meter's COMTRADE waveform files.

Before you can view waveforms on your meter's webpages, you need to make sure your meter is configured to record waveforms by setting the nominal voltage.

1. Launch a browser and go to the IP address for your meter, entering valid login credentials when requested.
2. Go to the **Monitoring** tab and select **Waveforms**.

A screen displays with accordion menus for all 3 COMTRADE modules (regardless of whether or not that COMTRADE module is being created by the meter). The waveform viewer for COMTRADE\_1 is expanded.

By default, COMTRADE\_1 displays the sag/swell waveform records. COMTRADE\_2 and COMTRADE\_3 are used if you have configured additional waveform recorders and connected them to COMTRADE modules.

3. Select the accordion menu for the COMTRADE records you want to view, for example COMTRADE\_2.

The waveform viewer for those COMTRADE records is displayed.

4. Select the file you want to view from the record dropdown.

The numbering starts at 0 (zero), which means you select cmt0\_00004 to view the fifth file for COMTRADE\_1.

5. Click or tap an individual voltage or current channel in the legend to show or hide it in the waveform viewer.
  - Visible
  - Hidden
6. Use the bar at the bottom to zoom in / zoom out on a particular section of the waveform, or to scan through the waveform with the selected zoom level.

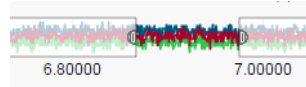

- Draw a window over a particular area to zoom in on that section of the waveform.
  - Drag the selected area to move the zoom across the waveform.
  - Drag the start and end points to expand or narrow the zoom.
7. Hover over or tap a spot on the waveform to view the values associated with that particular moment in time.

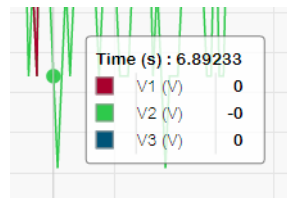

# Verifying accuracy

## Overview of meter accuracy

All meters are tested and verified at the factory in accordance with International Electrotechnical Commission (IEC) and American National Standards Institute (ANSI) standards.

Your digital power meter typically does not require re-calibration. However, in some installations a final accuracy verification of the meters is required, especially if the meters will be used for revenue or billing applications.

## Accuracy test requirements

The most common method for testing meter accuracy is to apply test voltages and currents from a stable power source and compare the meter's readings with readings from a reference device or energy standard.

### Signal and power source

The meter maintains its accuracy during voltage and current signal source variations but its energy pulsing output needs a stable test signal to help produce accurate test pulses. The meter's energy pulsing mechanism needs approximately 10 seconds to stabilize after every source adjustment.

The meter must be connected to control power in order to conduct accuracy verification testing. Refer to your meter's installation documentation for power supply specifications.

### **⚠ DANGER**

#### **HAZARD OF ELECTRIC SHOCK, EXPLOSION, OR ARC FLASH**

**Failure to follow these instructions will result in death or serious injury.**

Verify the device's power source meets the specifications for your device's power supply.

### Control equipment

Control equipment is required for counting and timing the pulse outputs from an energy pulsing LED or digital output.

- Most standard test benches have an arm equipped with optical sensors to detect LED pulses (the photodiode circuitry converts detected light into a voltage signal).
- The reference device or energy standard typically has digital inputs that can detect and count pulses coming from an external source (i.e., the meter's digital output).

**NOTE:** The optical sensors on the test bench can be disrupted by strong sources of ambient light (such as camera flashes, florescent tubes, sunlight reflections, floodlights, etc.). This can cause test errors. Use a hood, if necessary, to block out ambient light.

## Environment

The meter should be tested at the same temperature as the testing equipment. The ideal temperature is about 23 °C (73 °F). Make sure the meter is warmed up sufficiently before testing.

A warm-up time of 30 minutes is recommended before beginning energy accuracy verification testing. At the factory, the meters are warmed up to their typical operating temperature before calibration to help ensure that the meters will reach their optimal accuracy at operating temperature.

Most high precision electronic equipment requires a warm up time before it reaches its specified performance levels. Energy meter standards allow the manufacturers to specify meter accuracy derating due to ambient temperature changes and self-heating.

Your meter complies with and meets the requirements of these energy metering standards.

For a list of accuracy standards that your meter complies to, contact your local Siemens Industry representative or download the meter brochure from [www.usa.siemens.com/pds](http://www.usa.siemens.com/pds).

## Reference device or energy standard

To help ensure the accuracy of the test, it is recommended that you use a reference device or reference energy standard with a specified accuracy that is 6 to 10 times more accurate than the meter under test. Before you start testing, the reference device or energy standard should be warmed up as recommended by its manufacturer.

**NOTE:** Verify the accuracy and precision of all measurement equipment used in accuracy testing (for example, voltmeters, ammeters, power factor meters).

## Energy pulsing

Your meter has energy pulsing LEDs and a digital output that can be used for energy pulsing.

Your meter has energy pulsing LEDs, one visible light and one infrared. These LEDs emit pulses that are then used to determine the accuracy of the meter's energy measurements. The pulses of light indicate accumulated energy; the meter's accumulations are compared with the reference/standard's accumulated energy in order to help determine the meter's accuracy.

Your meter also has a digital output that can be used for energy pulsing. The relay closes (low impedance) and then opens (high impedance) to represent a pulse. If the accuracy testing equipment has a voltage requirement, a current-limited wetting supply voltage must be provided.

**NOTE:** Digital outputs on option modules should not be used meter accuracy testing.

### Related Topics

- LED locations

## Verifying accuracy test meter settings

Your meter 's power system and other parameters must be configured for accuracy testing.

Meter parameter	Value
Volts mode	4W-Wye (4 wire Wye)
PT/CT correction	Disabled

## Verifying accuracy test

The following tests are guidelines for accuracy testing your meter; your meter shop may have specific testing methods.

### ⚠ DANGER

#### HAZARD OF ELECTRIC SHOCK, EXPLOSION, OR ARC FLASH

**Failure to follow these instructions will result in death or serious injury.**

- Apply appropriate personal protective equipment (PPE) and follow safe electrical work practices. See NFPA 70E in the USA, CSA Z462 or applicable local standards.
- Turn off all power supplying this device and the equipment in which it is installed before working on the device or equipment.
- Always use a properly rated voltage sensing device to confirm that all power is off.
- Do not exceed the device's ratings for maximum limits.
- Verify the device's power source meets the specifications for your device's power supply.

1. Turn off all power supplying this device and the equipment in which it is installed before working on the device or equipment.
2. Use a properly rated voltage sensing device to confirm that all power is off.
3. Connect the test voltage and current source to the reference device or energy standard. Ensure all voltage inputs to the meter under test are connected in parallel and all current inputs are connected in series.

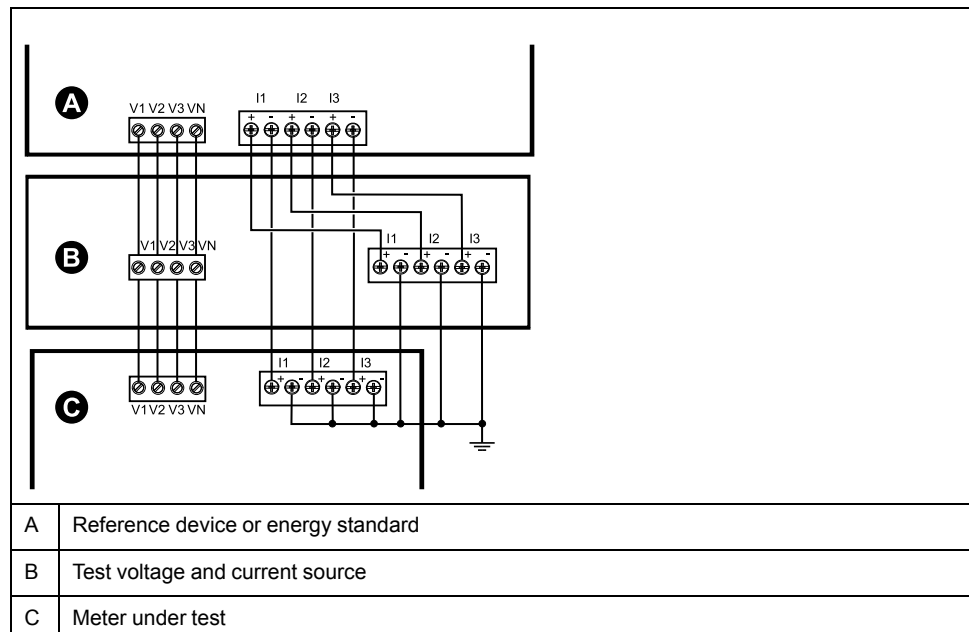

4. Connect the control equipment used for counting the standard output pulses using one of these methods:

Option	Description
Energy pulsing LED	Align the red light sensor on the standard test bench armature over the energy pulsing LED.
Digital output	Connect the meter's digital output to the standard test bench pulse counting connections.

**NOTE:** When selecting which method to use, be aware that energy pulsing LEDs and digital outputs have different pulse rate limits.

5. Before performing the verification test, let the test equipment power up the meter and apply voltage for at least 30 seconds. This helps stabilize the internal circuitry of the meter.
6. Configure the meter's parameters for verifying accuracy testing.
7. Depending on the method selected for counting the energy pulses, configure the meter's energy pulsing LED or one of the digital outputs to perform energy pulsing. Set the meter's energy pulse constant so it is in sync with the reference test equipment.
8. Perform accuracy verification on the test points. Run each test point for at least 30 seconds to allow the test bench equipment to read an adequate number of pulses. Allow 10 seconds of dwell time between test points.

## Calculate the number of required pulses

The reference test equipment typically requires you to specify the number of pulses required for a test duration of "t" seconds.

Normally, the number of pulses required is at least 25 pulses, and the test duration is greater than 30 seconds.

Use the following formula to calculate the required number of pulses:

$\text{Number of pulses} = \frac{N_e * V * I * PF * t}{3600 * Kt}$	
N <sub>e</sub>	Number of metering elements used
V	Test point voltage in line-to-neutral volts (V) per phase
I	Test point current in amps (A) per phase
t	Test duration in seconds (s) which must be longer than 30 seconds
PF	Power factor
Kt	Pulse constant programmed in the meter under test in Wh/pulse

Round up the result of the calculation to the nearest integer number of pulses.

## Calculation for number of required pulses

This example calculates the number of pulses required for an inductive load 3-phase test point with a test duration of 60s; the source is configured to use V = 120V, I = 5A, PF = -0.5; the pulse constant of the meter under test is Kt = 1.8 Wh/pulse.

$$8.3 = \frac{3 * 120 \text{ V} * 5 \text{ A} * .5 * 60 \text{ s}}{3600 * 1.8}$$

Round the number up to the nearest integer: Number of pulses = 9

## Percentage error calculation for accuracy verification testing

Accuracy verification testing requires you to calculate the percentage error between the meter being tested and the reference/standard.

Calculate the percentage error for every test point using the following formula:

$$\text{Energy error} = (\text{EM} - \text{ES}) / \text{ES} \times 100\%$$

Where:

- EM = energy measured by the meter under test
- ES = energy measured by the reference device or energy standard.

**NOTE:** If accuracy verification reveals inaccuracies in your meter, they may be caused by typical sources of test errors. If there are no sources of test errors present, please contact your local Siemens Industry representative.

## Typical sources of test errors

If you see excessive errors during accuracy testing, examine your test setup and test procedures to eliminate typical sources of measurement errors.

Typical sources of accuracy verification testing errors include:

- Loose connections of voltage or current circuits, often caused by worn-out contacts or terminals. Inspect terminals of test equipment, cables, test harness and the meter under test.
- Meter ambient temperature is significantly different than 23 °C (73 °F).
- Floating (ungrounded) neutral voltage terminal in any configuration with unbalanced phase voltages.
- Inadequate meter control power, resulting in the meter resetting during the test procedure.
- Ambient light interference or sensitivity issues with the optical sensor.
- Unstable power source causing energy pulsing fluctuations.
- Incorrect test setup: not all phases connected to the reference device or the energy standard. All phases connected to the meter under test should also be connected to the reference meter/standard.
- Moisture (condensing humidity), debris or pollution present in the meter under test.

## Accuracy verification test points

The meter should be tested at full and light loads and at lagging (inductive) power factors to help ensure testing over the entire range of the meter.

The test amperage and voltage input rating are labeled on the meter. Refer to the installation sheet or data sheet for your meter's nominal current, voltage and frequency specifications.

<b>Watt-hour test point</b>	<b>Sample accuracy verification test point</b>
Full load	100% to 200% of the nominal current, 100% of the nominal voltage and nominal frequency at unity power factor or one (1).
Light load	10% of the nominal current, 100% of the nominal voltage and nominal frequency at unity power factor or one (1).
Inductive load (lagging power factor)	100% of the nominal current, 100% of the nominal voltage and nominal frequency at 0.50 lagging power factor (current lagging voltage by 60° phase angle).

<b>VAR-hour test point</b>	<b>Sample accuracy verification test point</b>
Full load	100% to 200% of the nominal current, 100% of the nominal voltage and nominal frequency at zero power factor (current lagging voltage by 90° phase angle).
Light load	10% of the nominal current, 100% of the nominal voltage and nominal frequency at zero power factor (current lagging voltage by 90° phase angle).
Inductive load (lagging power factor)	100% of the nominal current, 100% of the nominal voltage and nominal frequency at 0.87 lagging power factor (current lagging voltage by 30° phase angle).

# Revenue metering

## Revenue metering overview

Revenue metering is one of your device's primary features.

The main purpose of a revenue meter is to provide measurements that are within industry-accepted limits for accuracy over a defined range of operating conditions. It also provides adequate protection against unauthorized alteration of these measured quantities. International and national standards define industry accepted accuracy limits. National and utility-based standards regulate protection against unauthorized alteration of measured quantities.

## Components of revenue metering

To meet government regulations and utility security requirements, the meter incorporates three types of security systems.

The three types of security systems are:

- traditional anti-tamper mechanical seals on the meter
- a password-based security system for resetting meter values (for example, Peak Demand reset)
- a hardware-based security system that prevents modification of revenue quantities after the meter is locked

Refer to the installation guide shipped with your meter and accessories regarding the installation of these security features.

## Revenue firmware security features

Your revenue-specific meter has additional firmware security features.

- You can only upgrade to revenue-qualified firmware and frameworks.
- Your firmware upgrades are recorded in your meter's event log. An additional firmware upgrade log is stored on your meter. Contact technical support for information on upgrade log retrieval
- You cannot perform resets or configure some revenue-specific parameters on your meter while it is revenue-locked.

## Protected features and settings

Your meter has features and settings that cannot be changed while the meter is revenue-locked.

In order to prevent modifications to revenue-related settings and data on your meter, some of the features and parameters on your meter cannot be edited once the meter is revenue-locked. For a complete listing of revenue-locked features and settings, download the ION Device Template Reference, available from [www.usa.siemens.com/pds](http://www.usa.siemens.com/pds)

## Revenue meter pre-installation procedure

You must configure and revenue lock your meter before installation.

- Clear all meter data prior to installing your revenue meter.
- Unlock your revenue meter.
- Configure the required revenue settings specific for installation. Once the meter is locked, these settings cannot be changed.

**NOTE:** If you are using ION Setup to configure your meter, allow for any communication delays before removing power to your meter.

- Verify the revenue settings have been implemented.
- Revenue lock your meter.
- Verify the meter is revenue-locked.
- Install the meter according to your meter's install sheet.
- Install the voltage and current terminal covers according to the sealing kit installation instructions.

## Revenue locking

Revenue locking your meter helps prevent modifications to revenue-related settings and data on your meter, or tampering with your meter's voltage and current connections.

Revenue locking may be required to help meet government regulations and utility security requirements, or can be used to help ensure the validity of revenue data.

Download the ION Device Template Reference, available from [www.usa.siemens.com/pds](http://www.usa.siemens.com/pds) to view a complete listing of revenue-locked parameters and data.

See the meter's catalog pages, available from [www.usa.siemens.com/pds](http://www.usa.siemens.com/pds), or consult your local Siemens Industry representative for information about your device, its options and accessories.

### Related Topics

- Revenue lock LED behavior

## Revenue lock switch

You can revenue lock your meter using the revenue lock switch located on the meter base.

This switch is accessed through a sealable cover.

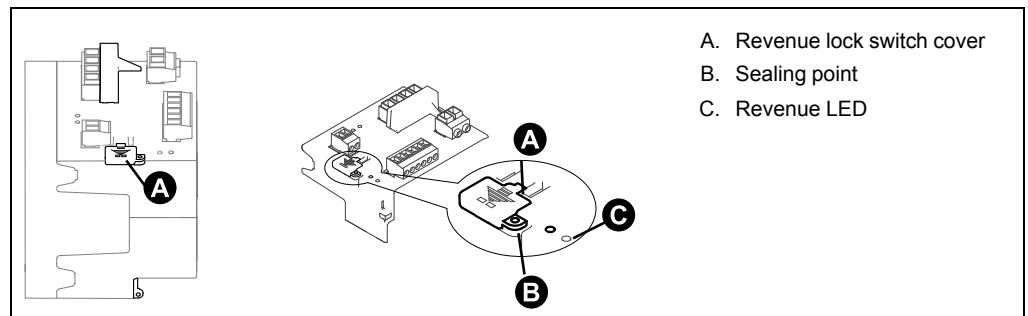

## Revenue locking your meter

You can lock and unlock your meter using the revenue lock switch located on the meter base.

### **⚠ DANGER**

#### **HAZARD OF ELECTRIC SHOCK, EXPLOSION OR ARC FLASH**

**Failure to follow these instructions will result in death or serious injury.**

- Apply appropriate personal protective equipment (PPE) and follow safe electrical work practices. See NFPA 70E in the USA, CSA Z462 or applicable local standards.
- Turn off all power supplying this device and the equipment in which it is installed before working on the device or equipment.
- Always use a properly rated voltage sensing device to confirm that all power is off.

1. Turn off all power supplying this device and the equipment in which it is installed before working on the device or equipment.
2. Always use a properly rated voltage sensing device to confirm that all power is off.
3. Open the revenue lock switch cover.
4. Locate the revenue lock switch.
5. Toggle revenue lock switch on or off.
6. Close the revenue lock switch cover and make sure it is firmly in place.
7. Seal the revenue lock switch cover if required.

## PT/CT correction

PT/CT correction, also called instrument transformer correction, can help reduce the need to replace transformers in installations where high accuracy is required.

The primary application for PT/CT (potential transformer / current transformer) correction is to apply correction factors for ratio errors and phase angle errors to instrument transformers. PT/CT correction is done for each current and voltage input to the meter and only affects 1-second power meter data and values derived from it, such as energy or demand. No high-speed, harmonics or waveform values are affected by the correction.

**NOTE:** For those familiar with ION architecture, the relevant 1-second Power Meter module outputs are compensated using the Instr Xformer (ITC) Correction module, and therefore so are all other modules that use that Power Meter module's data.

See the ION Setup online help, available from [www.usa.siemens.com/pds](http://www.usa.siemens.com/pds), for instructions on how to configure PT/CT correction on your device.

See the ION Reference, available from [www.usa.siemens.com/pds](http://www.usa.siemens.com/pds), for detailed information about the Instr Xformer Correction (ITC) module and how it applies PT/ CT correction to your device.

## Time of use

Time of use (TOU) is often used when a utility has set up schedules with different rates based on time of day, type of day and date when energy is consumed.

You can view the TOU active rates and seasons through your meter's display.

See the ION Setup online help, available from [www.usa.siemens.com/pds](http://www.usa.siemens.com/pds), for instructions on how to configure time of use on your meter.

See the ION Reference, available from [www.usa.siemens.com/pds](http://www.usa.siemens.com/pds), for a description of the Time of use module and its settings.

### Related Topics

- [Data viewing using your meter's display](#)

# Specifications overview

This section provides additional specifications for your meter and accessories.

The information contained in this section is subject to change without notice. You can download updated documentation from [www.usa.siemens.com/pds](http://www.usa.siemens.com/pds) or contact your local Siemens Industry representative for the latest updates.

See your device's installation sheet for specifications related to installation, such as measured current and voltage ranges, inputs/outputs and control power information.

## Mechanical characteristics

### 9410DC panel mount meter

Mounting position	Vertical
IP degree of protection	Display: IP54 Meter body: IP30 (except connectors)
Display type	1/4 VGA color graphic TFT LCD, 320 x 240 resolution
Display backlight	White LED
Viewable area	70.6 x 52.9 mm (2.78 x 2.08 in)
Keypad	5 button
Maximum number of option modules	4 (based on mechanical stress and required IP rating)

### 9410TC DIN meter

Mounting position	Horizontal TS35 DIN rail
IP degree of protection	Meter body: IP30 (except connectors)
Maximum number of option modules	4 (based on mechanical stress and required IP rating)

## Mechanical compliance

Vibration	IEC 60068-2-6
Shock	IEC 60068-2-27

## Electrical characteristics

True RMS 4-quadrant metering up to the 63rd harmonic on three-phase systems, 256 samples per cycle.

**NOTE:** Reactive energy and demand values are based on the fundamental, and do not include higher harmonics. Other energy and demand values are measured using the entire signal including harmonics. Contact Technical Support for more information.

**NOTE:** Table below assumes default configuration. Some values can be changed through framework and/or custom configuration.

## Measurement accuracy

IEC 62053-22 - active energy	Class 0.2S
IEC 62053-24 - reactive energy	Class 0.5S
IEC 61557-12	PMD/SD/K70/0.2 and PMD/SS/K70/0.2
Active power ( $P$ )	IEC 61557-12 Class 0.2 ( $\pm 0.2\%$ )
Reactive power ( $Q_V$ )	IEC 61557-12 Class 1 ( $\pm 1\%$ )
Apparent power ( $S_V$ )	IEC 61557-12 Class 0.2 ( $\pm 0.2\%$ )
Current ( $I$ )	IEC 61557-12 Class 0.2 ( $\pm 0.2\%$ )
Voltage ( $U$ )	IEC 61557-12 Class 0.2 ( $\pm 0.2\%$ )
Frequency ( $f$ )	IEC 61557-12 Class 0.02 ( $\pm 0.02\%$ )

## Power quality

IEC 61000-4-30 edition 2	Class S
IEC 62586-2 edition 1	
Voltage unbalance ( $U_{nb}$ )	IEC 61557-12 Class 0.2 ( $\pm 0.2\%$ )
Voltage harmonics ( $U_h$ )	IEC 61557-12 Class 1 ( $\pm 1\%$ )
Voltage THD ( $THD_u$ )	IEC 61557-12 Class 1 ( $\pm 1\%$ )
Current harmonics ( $I_h$ )	IEC 61557-12 Class 1 ( $\pm 1\%$ )
Current THD ( $THD_i$ )	IEC 61557-12 Class 1 ( $\pm 1\%$ )
Waveform capture	16 - 256 cycles per sample

## Voltage inputs

Specified accuracy range	57 to 400 V L-N / 100 to 690 V L-L (Wye) or 100 to 600 V L-L (Delta)
Specified accuracy frequency	42 to 69 Hz (50/60 Hz nominal)

## Current inputs

Specified accuracy current range	50 mA – 10 A
Withstand	20 A continuous, 50 A @ 10 sec/hr, 500 A @ 1 sec/hr
Burden	0.01 VA max at 5 A
Impedance	0.3 m $\Omega$ (typical)

## Standard control power

<b>AC control power</b>	
Operating range	50/60 Hz $\pm 10\%$ : 90 to 415 V AC L-N $\pm 10\%$ 400 Hz: 90 to 120 V AC $\pm 10\%$
Burden (meter only)	max: 7.2 W / 18 VA @ 415 V (45 – 65 Hz) max: 4.5 W / 8 VA @ 120 V (400 Hz)
Burden (fully optioned meter)	max: 18 W / 36 VA @ 415 V (45 – 60 Hz) max: 18 W / 28 VA @ 120 V (400 Hz)
Ride-through time	100 ms (6 cycles at 60 Hz) min., any condition 200 ms (12 cycles at 60 Hz) typ., 120 V AC 500 ms (30 cycles at 60 Hz) typ., 415 V AC

DC control power	
Operating range	110 to 415 V DC $\pm$ 15%
Burden (meter only)	max. 6 W at 300 V DC
Burden (fully optioned meter)	17 W at 300 V DC
Ride-through time	100 ms (6 cycles at 60 Hz) min., any condition

### Low-voltage DC control power

DC control power	
Operating range	20 to 60 V DC $\pm$ 10%
Burden (fully optioned meter)	max. 17 W at 18 to 60 V DC

### Digital output

Number	1
Type	Form A solid-state
Maximum load voltage	30 V AC / 60 V DC
Maximum load current	75 mA
ON resistance	13 – 40 $\Omega$ at 25 °C (77 °F)
Signal type	Continuous or pulse
Pulse frequency	$\leq$ 25 Hz

### Digital inputs

Number	3
Type	Externally excited, polarity independent
Event timestamp accuracy	$\pm$ 1 ms
Maximum voltage	30 V AC / 60 V DC
Pulse frequency	$\leq$ 25 Hz
Response time	20 ms
Minimum pulse width	20 ms
Current draw	ON: $\leq$ 2.5 mA OFF: $\leq$ 0.5 mA
ON state	4 to 30 V AC / 4 to 60 V DC
OFF state	0 to 1.4 V AC / 0 to 2.0 V DC
IRIG-B	IRIG-B00x format (unmodulated IRIG-B time code) Coded expressions 0 to 7 are supported but the year data is not used.

## Environmental characteristics

Operating temperature	-25 °C to Max temp (-13 °F to Max temp) Maximum operation temperature is based on the quantity and type of attached option modules. See <i>Maximum operating temperature, page 197</i> .
Storage temperature	-40 to 85 °C (-40 to 185 °F)
Humidity rating	5 – 95% RH non-condensing Maximum dewpoint: 37 °C (99 °F)

Pollution degree	2
Altitude	< 3000 m (9843 ft)
Location/mounting	Not suitable for wet locations For indoor use only Must be permanently connected and fixed

### Maximum operating temperature

Max temp	948M2DO6DI Digital (2 out, 6 in)	948M2AO4AI Analog (2 out, 4 in)
70 °C (158 °F)	0 – 4	0,1
70 °C (158 °F)	0	2
60 °C (140 °F)	1, 2	2 – 4

## LEDs

### Energy pulsing LEDs (visible and infrared) located on top of meter

Type	Visible orange, infrared
Wavelength	600 – 609 nm (orange) 825 – 925 nm (infrared)
Maximum pulse rate	< 25 Hz (based on line frequency)

## EMC (electromagnetic compatibility)

Product standards	IEC 62052-11 IEC 61326-1
Immunity to electrostatic discharge	IEC 61000-4-2
Immunity to radiated fields	IEC 61000-4-3
Immunity to fast transients	IEC 61000-4-4
Immunity to surges	IEC 61000-4-5
Immunity to conducted disturbances	IEC 61000-4-6
Immunity to voltage dips and interruptions	IEC 61000-4-11
Immunity to magnetic fields	IEC 61000-4-8
Immunity to ring waves	IEC 61000-4-12
Immunity to conducted disturbances, 2 - 150 kHz	CLC/TR 50579
Radiated and conducted emissions	FCC part 15 Class B, EN55011, EN55022 Class B, ICES-003 Class B
Surge withstand capacity (SWC)	ANSI C37.90.1

## Safety

Safety construction	IEC/EN 61010-1 ed.3, CAT III, 400 VLN / 690 V LL UL 61010-1 ed.3 and CSA-C22.2 No. 61010-1 ed.3, CATIII, 347 V LN / 600 V LL IEC/EN 62052-11, Protective Class II
---------------------	---

## Ethernet communications

Number of ports	2 (the second connector functions as an Ethernet switch for networking devices)
Maximum cable length	100 m (328 ft), per TIA/EIA 568-5-A
Cable type	CAT5/5e/6/6a
Connector type	Unshielded RJ45 modular connector (2)
Mode	10Base-T, 100Base-TX, Auto-MDIX
Data rate	up to 100 Mbps
FTP	Maximum simultaneous transfer connections (sessions): 2 Default timeout period: 90 seconds
IEC61850 maximum simultaneous client connections	4

## RS-485 communications

Number of ports	1
Maximum cable length	1200 m (4000 ft)
Maximum number of devices (unit loads)	Up to 32 devices on the same bus
Parity	None, even, odd
Baud rate	2400 – 115200, 19200 recommended

## Real-time clock

Clock drift (time error)	20 ppm max at 25 °C (77 °F)
Battery backup time	Minimum 7 years under specified storage conditions

## MID

Applicable MID standards and class index	<ul style="list-style-type: none"> <li>EN 50470-1:2006 Class C</li> <li>EN 50470-3:2006 Class C</li> </ul>
Type of measuring equipment	Static watt-hour meter
Mechanical environment	M1
Electromagnetic environment	E2
Cover sealing type	Wire and crimp
Applicable measurements	Active import/export energy metering

System types (for MID-compliant applications)	<ul style="list-style-type: none"> <li>• 3-phase 4-wire Wye grounded</li> <li>• 3-phase 3-wire Delta ungrounded</li> </ul>
Current rating	0.05 – 5(10)A
Nominal frequency	50 Hz
Energy pulsing LED	Pulse weight – 5000 imp/kWh
To comply with MID, the meter must be installed in MID certified cabinets rated for IP51 or better.	

## Remote display

See your remote meter display's installation sheet for additional remote meter display specifications.

IP degree of protection	Front: IP54 Rear: IP30
Cable	CAT5/5e/6/6a
Mounting position	Vertical
Display type	1/4 VGA color graphic TFT LCD 320 x 240 resolution
Display backlight	White LED
Viewable area	70.6 x 52.9 mm (2.78 x 2.08 in)
Keypad	5 button

## Option modules

See your option module's installation sheet for additional option module specifications.

### US2:948M2AO4AI Analog (2 out, 4 in)

Maximum number of modules	4
Input resistance	< 300 $\Omega$ (current mode) > 500 k $\Omega$ (voltage mode)
Max analog input current/voltage	20 mA / 30 V DC
Maximum meter operating temperature	25 °C to Max temp (-13 °F to Max temp) Maximum operation temperature is based on the quantity and type of attached option modules. See <i>Maximum operating temperature</i> , page 197.

### US2:948M2DO6DI Digital (2 out, 4 in)

Maximum number of modules	4
Maximum meter operating temperature	-25 °C to Max temp (-13 °F to Max temp) Maximum operation temperature is based on the quantity and type of attached option modules. See <i>Maximum operating temperature</i> , page 197.

## Other

Meter start time	Typical: 18 seconds (power up to measurement)
Meter memory	500 MB

---

Data update rate	Regular data: 1 second High-speed: 50 – 60 Hz half-cycle
Advanced security users	Up to 50 users



Printed in.  
Siemens Industry, Inc.  
5400 Triangle Parkway  
Norcross, GA 30092  
USA

Siemens Industry, Inc.  
5400 Triangle Parkway  
Norcross, GA 30092  
USA

For more information visit [www.usa.siemens.com/pds](http://www.usa.siemens.com/pds)

Search for the nearest sales office at  
[www.usa.siemens.com/pds](http://www.usa.siemens.com/pds)  
or call  
1.800.241.3138

Contact the Power Distribution Solutions (PDS) Service and Support at:  
Operating hours: 8:00 am — 5:00 pm EST Monday — Friday  
Phone: 1-800-333-7421  
[www.usa.siemens.com/pds](http://www.usa.siemens.com/pds)