

**SIEMENS**

# I-T-E<sup>®</sup> XL-U<sup>®</sup> Busway Systems

Selection  
and Application  
Guide



Product Family	Catalog Number	Description	Final Buy Availability	Last Day for Buy	Lead Time
XL-U	UJC3400G	BUS PLUG C/B 400A 600V 3P GND	No	N/A	N/A
XL-U	UJC4400G	BUS PLUG C/B 400A 600V 4P GND	No	N/A	N/A
XL-U	ULC3600G	BUS PLUG C/B 600A 600V 3P GND	No	N/A	N/A
XL-U	ULC4600G	BUS PLUG C/B 600A 600V 4P GND	No	N/A	N/A
XL-U	UMC3800G	BUS PLUG C/B 800A 600V 3P GND	Yes	6/15/2014	*
XL-U	UMC4800G	BUS PLUG C/B 800A 600V 4P GND	Yes	6/15/2014	*
XL-U	UV325G	BUS PLUG FUSIBLE 400A 240V 3P GND	Yes	6/15/2014	*
XL-U	UV326G	BUS PLUG FUSIBLE 600A 240V 3P GND	Yes	6/15/2014	*
XL-U	UV365LK	LUG EXTENSION KIT FOR UV365	No	N/A	N/A
XL-U	UV365SG	BUS PLUG FUSIBLE 400A 600V 3P GND	No	N/A	N/A
XL-U	UV366G	BUS PLUG FUSIBLE 600A 600V 3P GND	Yes	6/15/2014	*
XL-U	UV366GR	BUS PLUG FUSIBLE 600A 600V 3P GND	Yes	6/15/2014	*
XL-U	UV425G	BUS PLUG FUSIBLE 400A 240V 4P GND	Yes	6/15/2014	*
XL-U	UV426G	BUS PLUG FUSIBLE 600A 240V 4P GND	Yes	6/15/2014	*
XL-U	UV465SG	BUS PLUG FUSIBLE 400A 600V 4P GND	No	N/A	N/A
XL-U	UV466G	BUS PLUG FUSIBLE 600A 600V 4P GND	Yes	6/15/2014	*

\* Schedules will be established at order placement and will be within 16 weeks if parts are available. If parts cannot be obtained, some versions will not be available. Date and availability information will be provided at order placement.

## Paired-Phase Bus Bars Keep Motors Running Smoothly.

### Types:

Indoor: Feeder or Plug-in, Ventilated or Non-Ventilated

Outdoor: Feeder, Ventilated or Non-Ventilated

### Capacities:

To 5,000 amperes (aluminum)

To 6,500 amperes (copper)

### Conductors:

3-pole, 3 phase, 3 wire or 3 phase, 4 wire with full capacity neutral.

Continuous, internal ground bus is standard in ventilated busway and optional in non-ventilated designs.

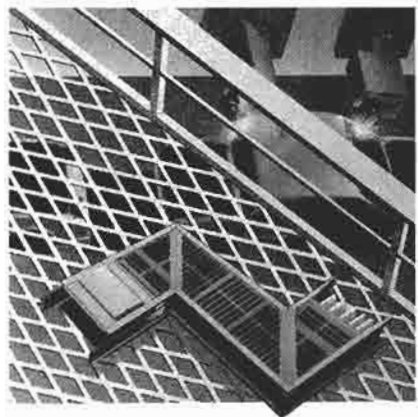

## Contents

Applications, Features and Benefits	1-3
Standard and Plug-In Sections	4
Elbows	5-6
Tees	7
Crosses	8
Hangers, End Closers and Wall Flanges	9
Tap Boxes	10-11
Unique Joint Stack Design	11
Reducers and Expansion Sections	12
Flanged End Connections, Drilling Details, and Switchboard Connections	13
Bus Plugs	14-16
Installation	17-19
Voltage Charts and Typical Specifications	20

# XL-U<sup>®</sup> Busway Is A Proven Performer With A Reputation For Outstanding Quality.

The XL-U busway system is a compact, economical way to handle loads up to 6500 amperes with confidence and flexibility second to none. The air-cooled XL-U busway system with paired-phase bus bars minimizes voltage drop and temperature build-up, even under unbalanced loads.

## Simple, Flexible Design Assures Years of Service

Steel, glass-filled polyester insulators, silver-plated bus bars—either copper or aluminum—and insulating air are its basic components. The XL-U busway system's uncomplicated design makes it easier to control quality and reduce maintenance. It also assures flexibility in adapting to complex layouts or building contours, fitting into tight spaces and adding to or revising original systems.

## Fits Full Range of Load Requirements

XL-U busway is available with a capacity that will fit load requirements, large or small. Both feeder and plug-in busways may be ordered with ratings of 225 to 6500 amperes with copper bus bars or 225 to 5000 amperes with aluminum.

## Innovative Paired-Phase Bus Bars

Siemens invented the use of paired-phase bus bars. Paired phasing is a complete departure from conventional configuration. Bus bars are grouped in pairs and spaced so that AC current in each pair is nearly equal in magnitude and opposite in direction.

As a result, complete magnetic-field cancellation occurs and losses are low, while impedance is balanced and reduced to a minimum. Voltage drop and temperature rise are held to a minimum and kept uniform between conductors and throughout the run, even when loads are unbalanced. Electrical characteristics are identical for XL-U busway feeder and plug-in busway.

## Configured To Match Your Service Requirements

To match your service, busway construction may be 3 phase, 3 wire or 3 phase, 4 wire with full-capacity neutral. Continuous, internal ground bus is standard on all ventilated busway, and optional in non-ventilated designs.

## Compact Design

Space, of course, is a premium with today's rising construction costs. The XL-U busway's compact design and regular surface require minimum space. Outside dimensions are smaller than for most other busways. The 6500-ampere busway, for example, measures only 9½-inches x 20⅝-inches.

## Fast, Economical Installation

Regardless of the run or contour of the building, XL-U busway can be planned and installed easily and economically. Standard straight sections are available in one-foot increments from two to ten feet long. They are finished with a tough, baked-on gray enamel and are UL listed for horizontal mounting at 10-foot intervals. Joint-stack assembly, splice plates and cover plates are factory-installed at one end to save time in the field.

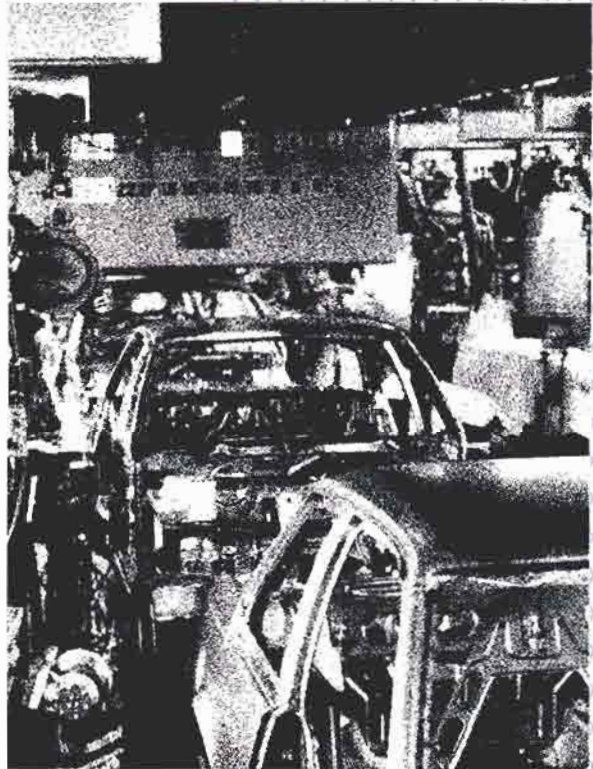
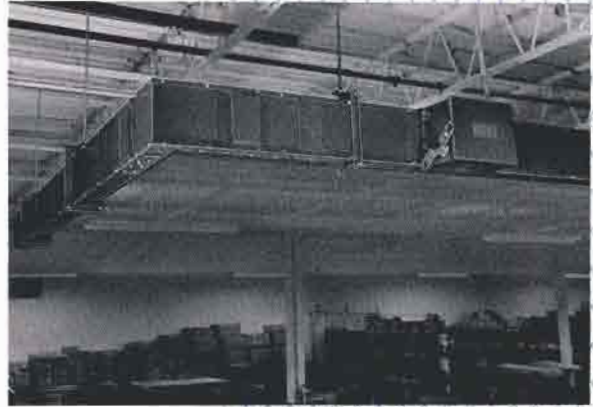

## XL-U® Busway Is Known For Its Versatility.



### Plug-In Loads Anywhere—In Seconds

A complete range of standard fittings allows direction changes that will adapt to any requirement. The XL-U busway's unique joint-stack design even permits assembly or replacement from any direction where space restrictions rule out telescoping connections. Plug-in openings are available on both sides of the busway housing and spaced every 24-inches, even across joints, allowing for 10 plug-in openings every 10 feet.

Prefabricated hangers and rod-hanger adaptors make it quick and easy to hang runs in any way building construction dictates. A load may be tapped off any joint or a plug or panel plugged directly into any busway opening.

Simply install a tap box or cubicle and you are ready for a branch-circuit run. Or for individual branch-circuit loads, just plug in one of the XL-U busway bus plugs. They are available for loads up to 800 amperes with circuit breaker or fusible protection.

### Safety Features That Exceed Industry Expectations

Design and construction of all components in the XL-U busway system follow rigid specifications established by our engineers which exceed industry expectations. Stringent precautions have been taken to reduce the hazard to operating and maintenance personnel at all times.

Removable plates are provided on each side of the XL-U busway joint connection, allowing convenient inspection at any time. These inspection covers may be removed without disturbing pressure or damaging integrity in any way.

Whenever a tap-off device is installed, it is automatically grounded against the casing or grounding conductor before electrical contact is made.

For additional protection, XL-U busway is designed to accommodate an internal ground bus bolted to the inside of the casing and running throughout the entire system from source to load. This provides a true, low-impedance ground path for the system. It is far more effective than other systems using externally mounted bus bars, extra neutrals or busway casing for ground return paths.

### Safety System Designed Into Bus Plugs and Bus Plug Openings

The coordinated design of plug-in openings and bus plugs offers a safety system that cannot be excelled. The sliding doors covering busway openings must be in the closed position when XL-U busway plugs are installed. As the bus plug is inserted into the openings, an insulated key interlock on the plug enters the busway and allows the door to be opened.

The plug is then inserted fully into the busway through the opened door. The same key interlock prevents the sliding door from closing on live parts. During insertion, the plug is automatically grounded against the casing or the separate internal grounding bus before the bus plug fingers contact the conductors.

### Meets Or Exceeds All Industry Standards

The XL-U busway system meets or exceeds all industry standards for feeder or plug-in busways. Each section carries the Underwriters Laboratories, Inc., label indicating its listing under busways file #E22174. Construction and performance more than meet the requirements for busways covered by Federal Specification W-B-811b, and NEMA requirements BU.1.

# XL-U® Busway Is Respected For Its Reliability.

## Totally Reliable And Reusable

What's more, an XL-U busway system is designed to outlive any number of plant expansions, new layouts or even new constructions. Simple assembly and installation methods allow you to take down, move and reinstall XL-U busway without sacrificing any of the sections, fittings or plug-ins that make it an economical, efficient, custom-built power supply.

When you compare features and costs for the total picture—planning, assembling, installing, operating, reusing—it's clear that XL-U busway offers many advantages over other power distribution systems.

## Unique, Double Insulation Offers Greater Assurance

Insulation has become increasingly important to busway systems as they are required to carry heavier electrical loads within smaller, more compact designs. Our unique, two-way insulation was developed to let XL-U busway operate cooler and more efficiently than other systems...at any load.

A continuous, uniform layer of polyvinylchloride is applied to the bus bars by the industry's first in-plant, fluidized-bed production line. This provides a film with no laps, no joints, no pinholes. The solid layer of insulation that results is impervious to acid and alkalis, and is also weatherproof. It will withstand temperatures up to 105°C (221°F).

## Insulated Two Ways For Superior Performance

Strong, rigid, track-resistant insulators molded of glass-filled polyester hold the individual, insulated bus bars in position within the external casings. They keep the bus bars away from the busway casing, thus preventing accidental contact with the grounded casing.

Completely surrounding each bus bar is XL-U busway's secondary insulator—air. Clean, cooling, insulating air constantly circulates throughout the busway length, dissipating heat and replenishing itself as needed.

## Rigid, Steel Protection Overall

Complete mechanical protection is provided by the rigid, symmetrical steel casing, which surrounds the bus-bar assembly. Each side of the four-sided busway construction has formed corners which interlock with adjacent sides to assure maximum rigidity in a clean-lined, compact design. The assembled busway is finished with a tough, baked-on gray enamel.

XL-U busway is available in both ventilated and non-ventilated construction, specifically designed to accommodate a full, internal ground bus when desired.

## Delivers Power Where You Need It

Measured by any standards, XL-U busway is the most versatile busway system available. With its wide range of ratings, fittings, bus plugs and installation methods, it is easily adapted to any application. Whatever the conditions, XL-U busway will let you put power where you need it...simply and economically.



# XL-U® Busway

## 3 Phase, 4 Wire Full Neutral

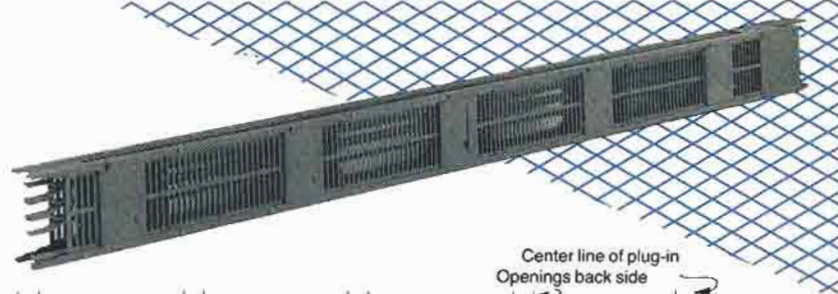

XL-U busway standard sections may be ordered with either copper or aluminum bus bars, ventilated or non-ventilated and in ratings from 225 to 6500 amperes, 600 volts. Plug-in sections with plug-in openings centered on 24-inch intervals are available, in 4-, 6-, 8- and 10-foot lengths.

All plug-in openings are of the safety-type with doors which require a specific sequence during the insertion or removal of the plug and ensure that the doors are closed after plug removal.

Casing size varies with the ampere capacity and type of conductor. Busways using copper conductors are smaller in size, while busways using aluminum are lighter.

Section lengths may be installed horizontally, either edgewise or flatwise. The cross sections are shown as edgewise mounted. They are painted with a baked-on gray enamel and are approved for horizontal mounting at 10-foot intervals.

Bus bars are arranged in a paired-phase configuration to increase current-carrying efficiency and they are insulated to accommodate a temperature rating of 105°C, surpassing the 85°C required for listing by Underwriters Laboratories, Inc. An internal-ground bus bar provides a low-impedance ground-return path.

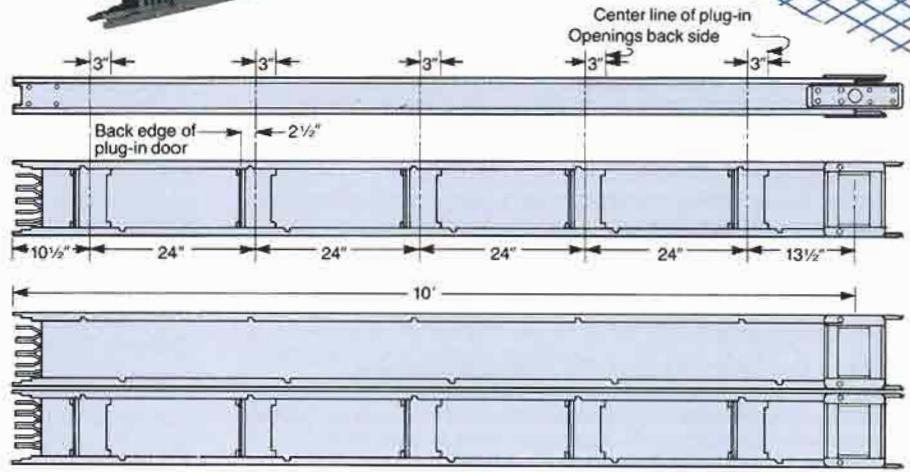

### XL-U® Busway Cross Section

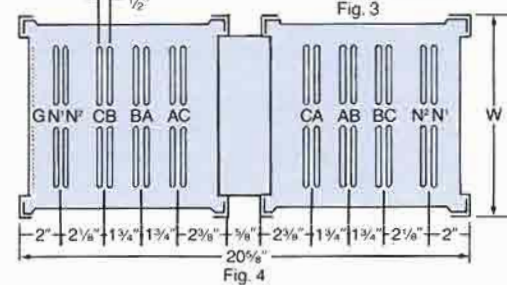
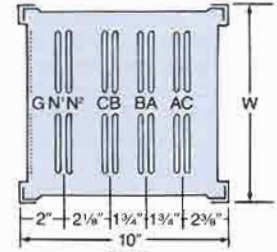
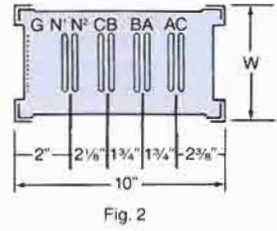
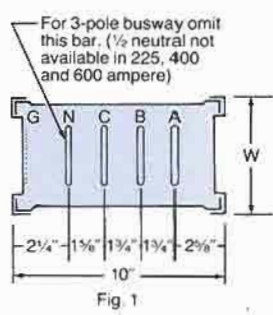

**Note:** Position of grounding bus is marked "G" as shown. In Fig. 4 for plug-in busway, grounding bus is located in plug-in part of section. For 3 phase busway, all full size neutral bars are omitted.

Fig. No.	W	Bus Bars					Copper Ampere Rating						Aluminum Ampere Rating						Ground Bus Capacity Maximum	
		Size of Conductors	Cross Sect. Area Sq. in Per Ø	Number of Conductors			Vent. -Bars on Edge		Vent. -Bars Flat		Totally Enclosed		Vent. -Bars on Edge		Vent. -Bars Flat		Totally Enclosed			
				Per Ø	FN	Grd. Bus	UL Rating	Std. Rating	UL Rating	Std. Rating	UL Rating	Std. Rating	UL Rating	Std. Rating	UL Rating	Std. Rating	UL Rating	Std. Rating		
1	4 1/2	.050 x 2	.101	1	1	1	225	225	225	225	225	225								100%
		1/4 x 1	.25	1	1	1							225	225	225	225	225	225		
		1/4 x 1 1/2	.375	1	1	1	400	400	400	400	400	400								
2	4 1/2	1/4 x 2	.50	1	1	1	600	600	600	600	600	600	400	400	400	400	400	400		50%
		5/8	1/4 x 3	.75	1	1	1							600	600	600	600	600	600	
		5 1/2	1/4 x 1	.50	2	2	1	800	800	800	800									
3	7 1/2	1/4 x 1 1/2	.75	2	2	1	1200	1200	1000	1000	800	800	800	800	800	800	800			50%
		1/4 x 2	1.0	2	2	1	1450	1350	1200	1200	1000	1000	1000	1000	900		800	800		
		1/4 x 2 1/2	1.25	2	2	1	1700	1600	1350	1350	1100		1250	1200	1000	1000	900			
4	7 1/2	1/4 x 3	1.5	2	2	1	2000	2000	1600	1600	1250	1200	1400	1350	1200	1200	1000	1000		25%
		9/16	1/4 x 1 1/2	1.5	4	4	2	2300		2000		1400	1350	1700	1600	1500	1350			
		9/16	1/4 x 2	2.0	4	4	2	2700	2500	2300	2000	1600	1600	2000	2000	1700	1600	1200	1200	
4	9 1/2	1/4 x 2 1/2	2.5	4	4	2	3000	3000	2500	2500	1900		2300		1900		1400	1350		
		1/4 x 3	3.0	4	4	2	3500	3500	2800	2800	2100	2000	2500	2500	2100	2000	1600	1600		
		7 1/2	1/4 x 1 1/2	3.0	8	8	2	4400	4000	4000	4000	2700	2500	3300	3000	3000	3000	2000	2000	
4	9 1/2	1/4 x 2	4.0	8	8	2	5200	5000	4600	4500	3200	3000	3900	3500	3500	3500	2500	2500		
		1/4 x 2 1/2	5.0	8	8	2	6000	6000	5000	5000	3700	3500	4500	4000	3900		2750			
4	9 1/2	1/4 x 3	6.0	8	8	2	6500	6500	5700	5500	4100	4000	5000	5000	4200	4000	3100	3000		

# XL-U<sup>®</sup> Busway

## Elbows

XL-U busway elbows provide a simple, convenient method of changing the direction of a busway run—to the right or left, up or down. A joint-stack assembly is furnished on one end for fast, direct connection to a busway section. Dimensions shown apply

### Flatwise Elbows

Used with busway sections mounted flatwise, these elbows have bus bars mounted in the horizontal plane, or parallel with the floor. Left-hand, LH-3, and right-hand, RH-1, elbows are identical except that the joint-stack assembly is mounted on opposite ends. This can easily be relocated in the field, if required, to serve either direction.

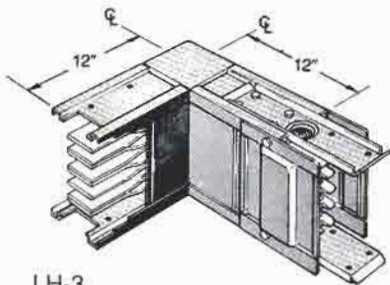

LH-3

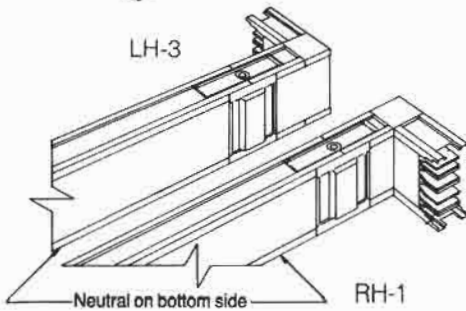

LH-3

RH-1

Neutral on bottom side

to elbows with one, two or four bars per phase, flatwise and edgewise, and eight bars per phase flatwise. For edgewise elbows with eight bars per phase, 12-inch dimensions become 18 inches.

### Edgewise Elbows

These elbows are used with edgewise busway sections and have bus bars mounted in the vertical plane, or at right angles to the floor. For the left-hand, LH-4, elbow, the nameplate, neutral and ground bus are located on the outside of the bend. For the right-hand, RH-2, they are located on the inside. Edgewise elbows are not interchangeable as in flatwise construction.



LH-4



RH-2

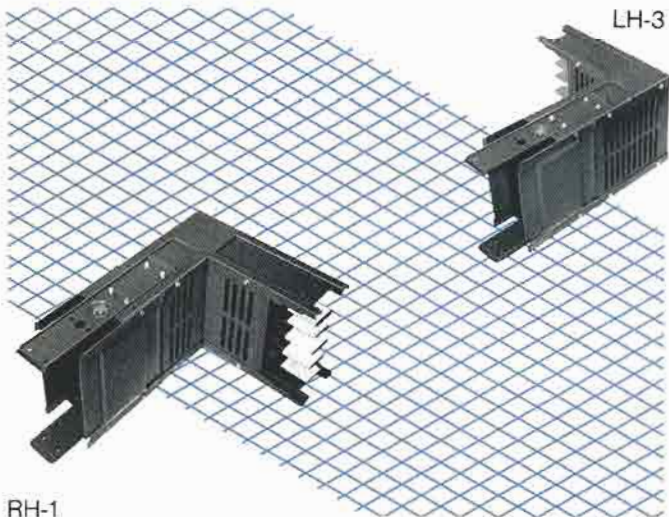

RH-1

LH-3

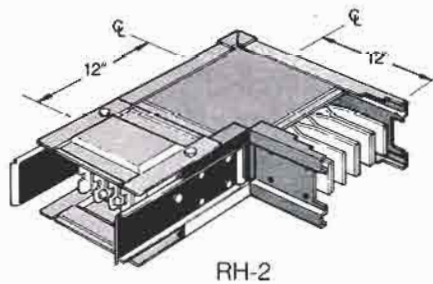

RH-2

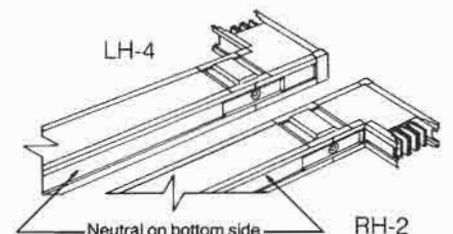

LH-4

RH-2

Neutral on bottom side

# XL-U® Busway

## Offset Elbows

Offsets can often be used to advantage to save space and solve difficult contour problems when encountered. A single offset may be used, for example, to replace two or more elbows and provide a more attractive, space-saving way to bypass obstructions. Offsets may also be used to convert an edgewise run to flatwise, or vice versa.

XL-U busway offsets are manufactured in an infinite variety of shapes, each designed to perform a necessary function and occupy less space than a pair of standard elbows. Because of this variety, care should be taken on all dimensional drawings. Positioning of the joint stack, one furnished with each offset elbow, is especially important. Its position should be indicated on all drawings.

### Double Offset Elbows

Flatwise  
Double Offset

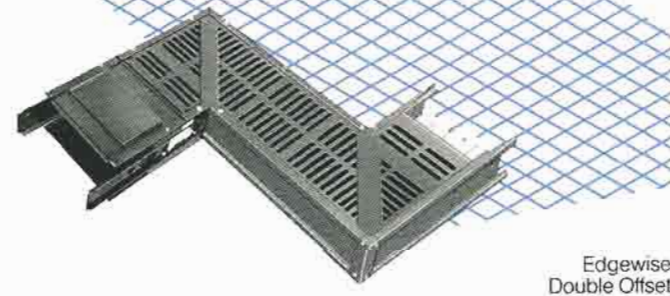
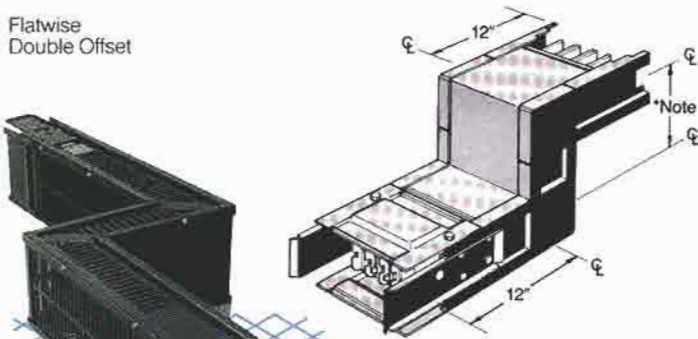

Edgewise  
Double Offset

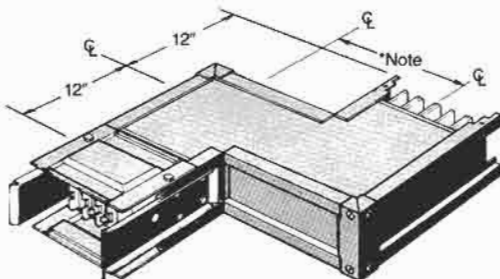

**Note:** The center leg of a double elbow can be any length under two feet. Two elbows are used for lengths two feet and over.

**Note:** 12-inch dimension becomes 18-inch where eight-bar edgewise offsets are required.

### Edge-To-Flat Offset Elbows

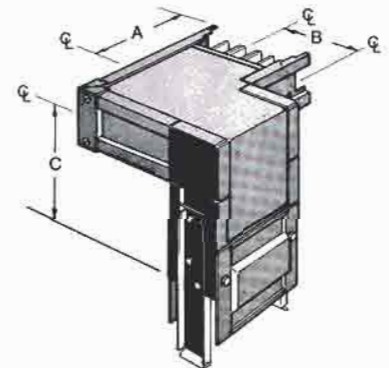

Dimensions (In Inches)			
Casing Size	"A"	"B"	"C"
4½ x 10	12	12	12
5½ x 10			
7½ x 10			
9½ x 10			
7½ x 20½	18	18	12
9½ x 20½			

# XL-U® Busway

Tees

XL-U busway tees simplify branch runs of busway from the parent feeder run or feeding branch run. They are available edgewise or flatwise, right-hand or left-hand. Two joint-stack assemblies are provided with each tee. The edgewise tee is housed inside a special box enclosure to provide rigidity and shield against dirt and dust. Standard tees do not contain plug-in openings.

It is important to carefully note the size of the box enclosure when laying out an edgewise busway. The chart below clarifies dimensions.

## Flatwise Tees

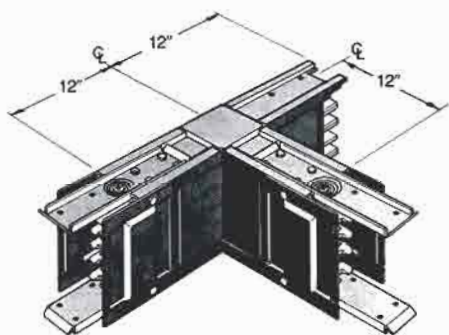
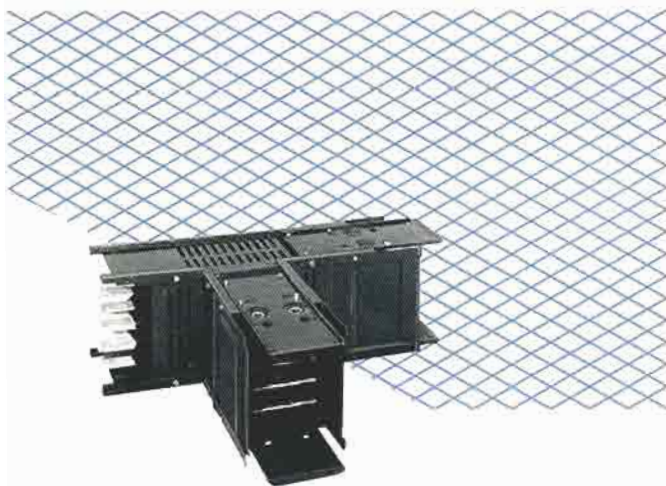

## Edgewise Tees

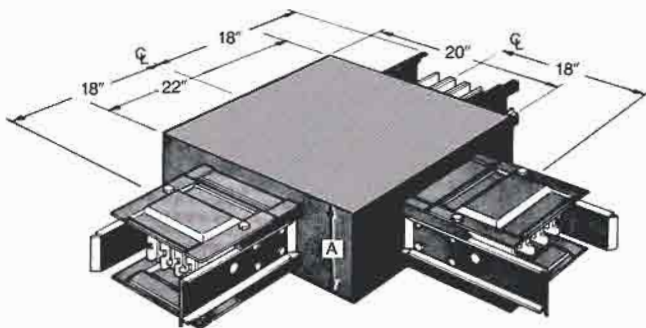

Dimensions (In Inches)	
Casing Size	"W"
4½	8
5½	8
7½	12
9½	12

# XL-U<sup>®</sup> Busway

Crosses

Factory-assembled crosses provide an easy method of tapping off two branch runs from a single point in the main run. Two joint-stack assemblies are provided with each XL-U busway

cross. Standard crosses do not contain plug-in openings. Flatwise or edgewise crosses are available in the sizes shown below.

## Flatwise Crosses

## Edgewise Crosses

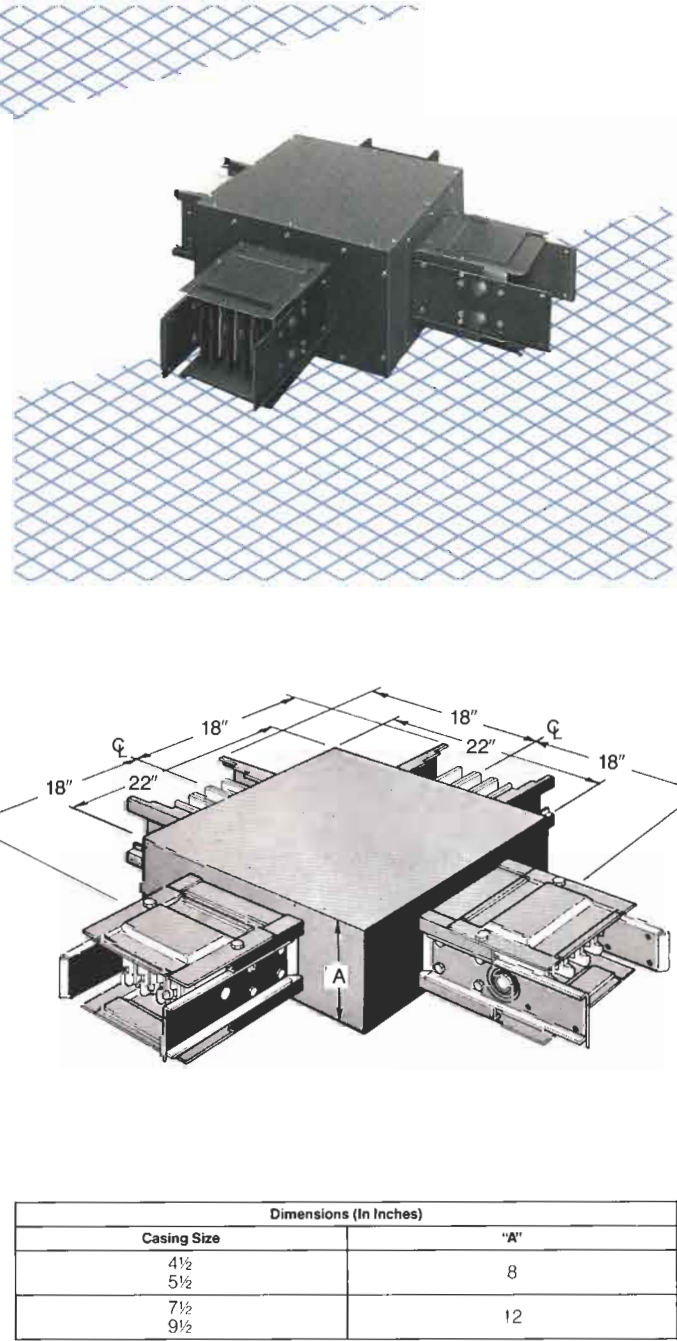
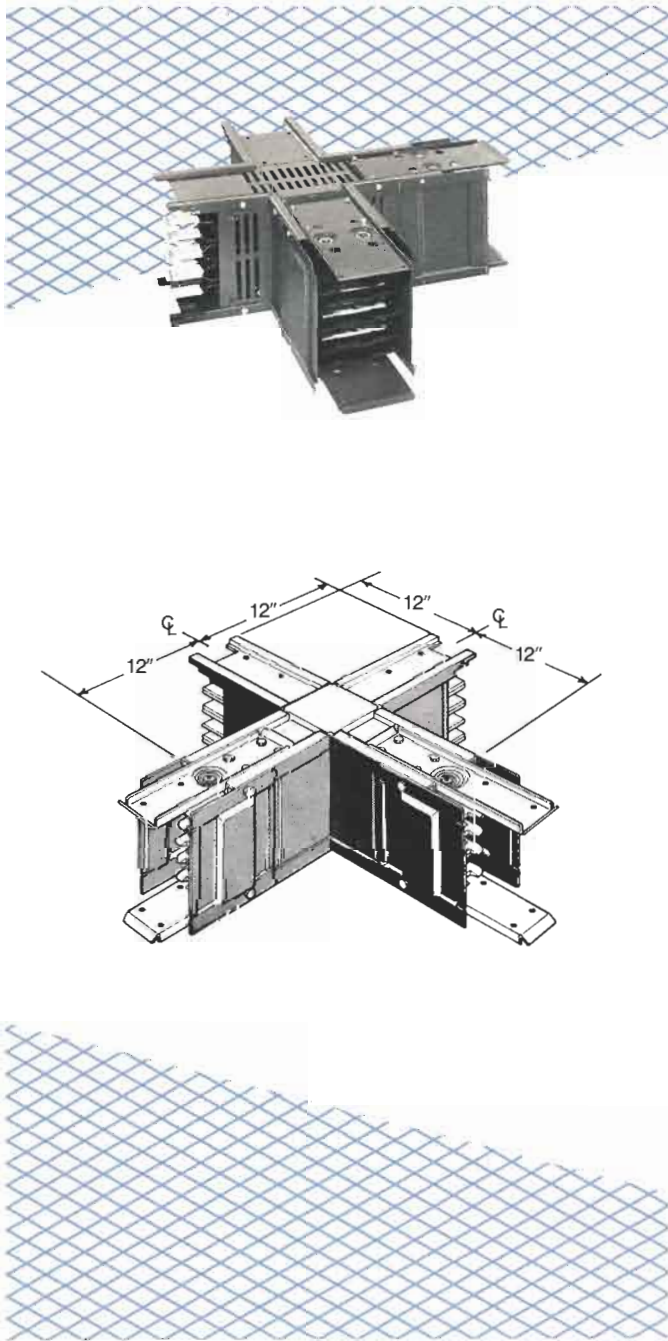

Dimensions (In Inches)	
Casing Size	"A"
4½	8
5½	
7½	12
9½	

# XL-U® Busway

## Standard Hangers

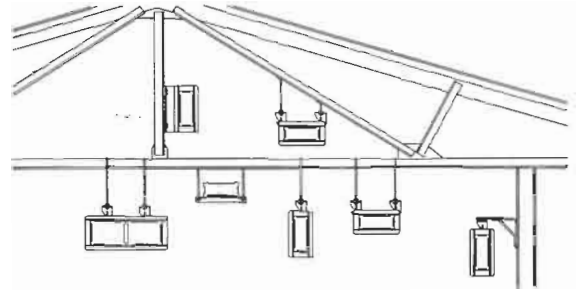

Standard picture frame hangers are used for horizontal busway suspension. One hanger assembly is provided with each straight section and with each fitting. The pre-drilled hangers bolt together at the corners and can be slid over section lengths. It is not necessary to bolt or screw the hangers to casings.

Edgewise mounting, particularly in the higher ampere busway, may require two-point suspension from each hanger to provide increased rigidity. To speed installation, UJ100 adaptors are recommended for use with the hangers. XL-U busway runs can be mounted on ten-foot centers.

Consult sales office if special hanging or suspension is required.

Dimensions (In Inches)				
Casing Size	"A"	"B"	"C"	"D"
4½ x 10	7¾	6¼	13¼	11¾
5½ x 10	8¾	7½	13¼	11¾
7½ x 10	10¾	9¾	13¼	11¾
9½ x 10	12¾	11¾	13¼	11¾
7½ x 21	10¾	9¾	24	22½
9½ x 21	12¾	11¾	24	22½

### Wall Flanges

Wall flanges are designed to close off the area around the busway where it passes through a wall. A flange IS NOT INTENDED to provide an air tight seal around the busway. THE INSTALLER WILL BE

RESPONSIBLE FOR ANY ADDITIONAL CAULKING OR SEALING TO MEET LOCAL CODES. By using a wall flange as shown, it can be mounted at any point along a busway run.

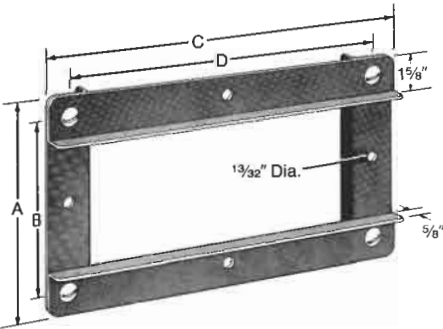
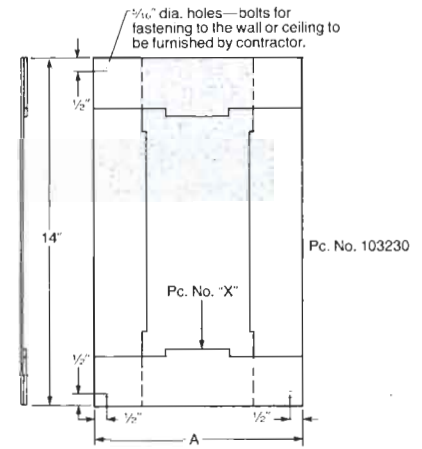
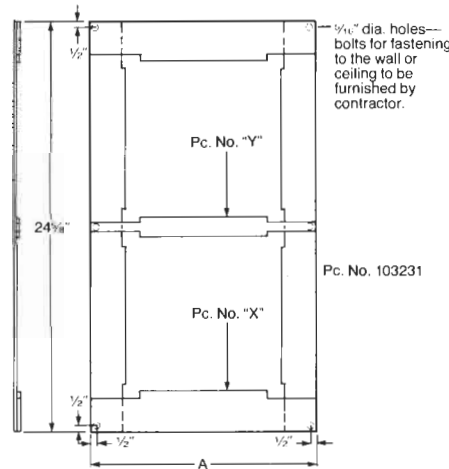

Casing Size	Dimensions (In Inches)		Piece Numbers	
	"A"	"X"	"X"	"Y"
7½ x 20 5/8	11½	103228	103232	
9½ x 20 5/8	13½	103229	103233	

**Note:** This wall flange can be mounted at any point along a busway by using it as shown.

Dimensions (In Inches)	
Casing Size	"A"
4½ x 10	8½
5½ x 10	9½
7½ x 10	11½
9½ x 10	13½

### End Closers

End closers are used to terminate busway runs simply and safely. They can be removed easily, at any time, if the run is to be extended.

### Rod-Hanger Adaptors

The exclusive UJ100 rod-hanger adaptor saves additional time and money when busway is hung from standard hanging rods. Made of heavy gauge formed steel, they mount quickly on previously positioned hanging rods. Then, the busway can be lifted into position and the supporting bolt from hanger slide into the adaptor slot. Tighten the bolt and the busway is installed. These adaptors are designed to prevent twisting of the busway and to eliminate costly on-the-job metalworking. When busway is hung flatwise from rods or straps, one UJ100 adaptor per hanger is sufficient.



# XL-U® Busway

## Tap Boxes

### Center-Cable Tap Boxes—Non-Fusible

Center-cable tap boxes are non-fusible devices for cable or conduit tap, off or feed in. One, two, and four bars per pole, they consist of a joint stack mounted in an enclosure and may be installed at any XL-U busway joint. To install, the joint-splice plates must be removed and the existing joint-stack slid out of the busway. When the tap box is attached in position, its joint-stack replaces the one removed.

The box may be reversed to provide wiring space on the left-hand side of the box instead of the right side. Lugs suitable for copper or aluminum conductors are provided as shown in table.

Busway Ampere Rating		Tap Box Ampere Rating Maximum	Dimensions (In Inches)		
Aluminum	Copper		"A"	"B"	"C"
225-600	225-600	600	24	12	18
800-2500	800-3500	600	26	12	18
		1200	32	18	18
		2000	32	18	18

Phase lugs are #4-600 MCM Al lugs.  
GND lugs are #6-350 MCM Al lugs.

Tap Box Ampere Rating (Maximum)	Lug Quantity		Gutter (In Inches)
	Phase	Ground	
600	2	1	14 min.
1200	4	1	20 min.
2000	6	2	20 min.

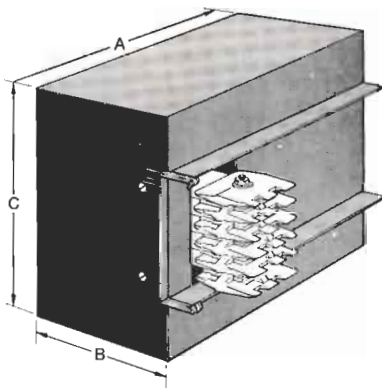

### Center-Cable Tap Box 8 Bars/3 or 4 Poles

The center cable tap box for 8 bars/pole consists of an enclosure and a busway stub on each end. The size of this enclosure will vary with its lug requirements. (See table below.)

Tap Box Capacity	Dimensions (In Inches)			#4-600 MCM Lugs/Pole
	"A"	"B"	"C"	
600A	4'-0"	24	30	2
1350A	5'-0"	36	30	4
2000A	5'-0"	36	36	6
over 2000A	Consult Factory			

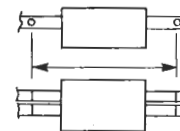
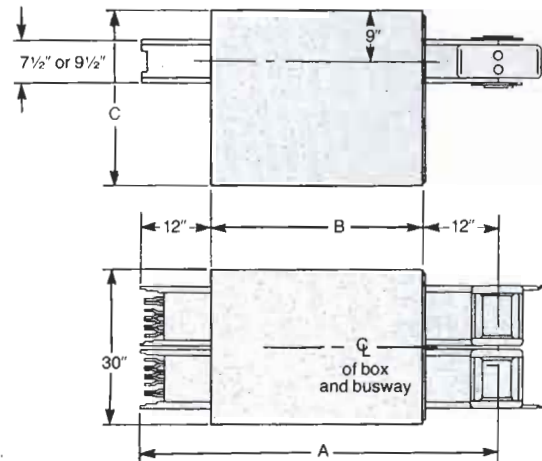

Schematic Breakdown

# XL-U® Busway

Unique Joint Stack Design

## End-Cable Tap Boxes—Non-Fusible

End-cable tap boxes are non-fusible devices that attach to the end of an XL-U busway run. Each box includes a joint-stack assembly, and is suitable for flatwise or edgewise mounting at either end of the run. Lugs suitable for copper or aluminum conductors are provided as shown in the table.

Busway Amperes Rating		Dimensions (In Inches)				
Copper	Aluminum	"A"	"B"	"C"	"D"	Gutter
225	225	20	14	8	4	10
400-600	400-600	24	18	12	4	15
800-2000	800-1350	32	18	16	4	20
2500-3500	1600-2500	32	18	18	6	

Ampere Rating	Phase Lugs		Ground Lugs	
	Quantity/Phase	Range	Quantity	Range
225	1	#6-350	1	#6-350 MCM
400	1	#4-600 MCM		
600	2			
800	3			
1000-1350	4	#4-600 MCM	2	#6-350 MCM
1600	5			
2000	6			
2500	8			
3000	9			
3500	11			

## Joint Design Makes it Possible

Key to this simple installation procedure is the basic joint-stack design which produces a rugged, cool operating bus-bar connection with a minimum of effort. Occasionally, building obstructions do not allow space for the usual telescoping motion that slides sections into position for joining. When this occurs—whether or not it was indicated on original plans—joint-stack, splice plates and cover plates are easily removed so that the flush busway ends may be positioned from any direction. Then the joint is reassembled and completed in the usual fashion. The same technique may be used to replace a previously installed busway section without disturbing adjacent sections.

## Tap-Offs Take Only Minutes

In the same way, this unique joint-stack makes it easy to add a tap box or cubicle at any joint. Just replace the joint-stack with a standard tap stack, bolt on the appropriate enclosure and you have the start of a new power run.

## Complex Layouts Go Up Fast With Standard Fittings

This same joint design in all XL-U busway standard fittings cuts installation time for the most complex busway layouts. Change direction, add cross runs, even change busway sizes wherever your layout or building contours require it. Fittings are available to do the job quickly and easily—with the same one-two-three joint assembly. Switchboard connections, with the XL-U busway joint-stack on one end and bus-bar extensions and a bolt-on flange plate on the other, provide simple, direct connections between a busway run and a switchboard or panelboard.

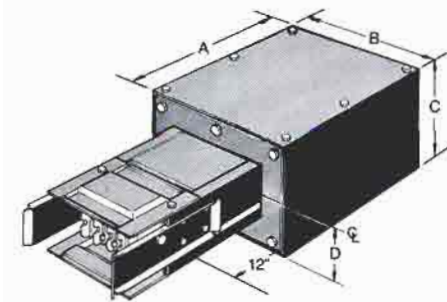
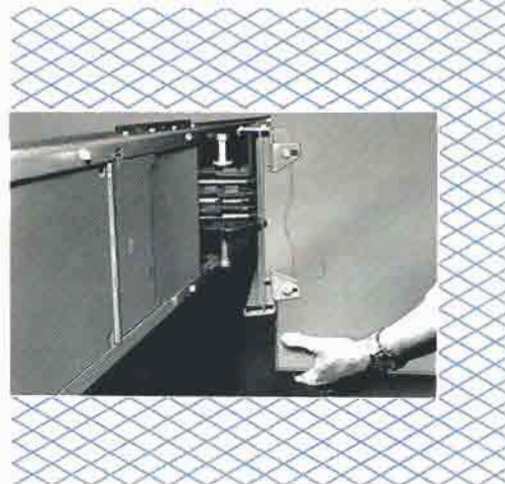
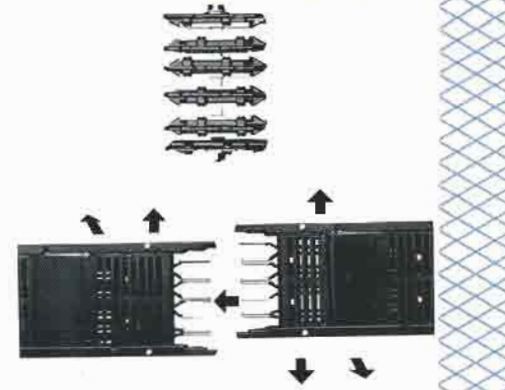
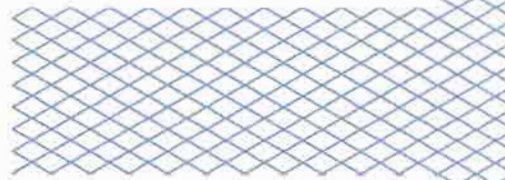
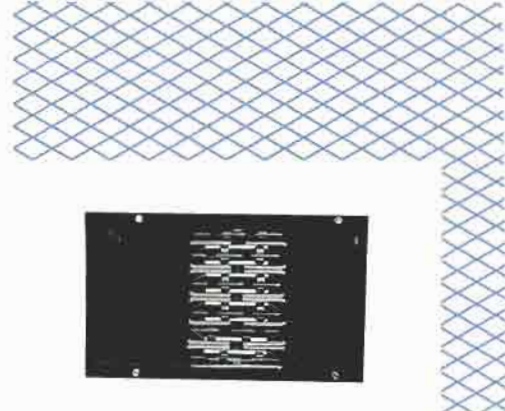

# XL-U<sup>®</sup> Busway

## Reducers And Expansion Sections

### Reducers—Non-Fusible

XL-U busway reducers are factory-assembled fittings that allow changing from one casing size to a smaller size in a busway run. A joint-stack assembly and connecting plates are supplied for each end of the reducer to facilitate installation. These reducers are non-fusible and measure four feet in length. They can also be supplied in longer lengths and with provisions for any type of fuse protection desired.

Reducers are not required when busway ratings change during a run *if* both ratings take the same casing size and the same number of conductor bars per phase. For example: both 800 and 1350 ampere ventilated copper busways, mounted edgewise, use 4½-inch x 10-inch casings and have two bars per phase. No reducer would be required to change from one to the other in such a busway run. The reduced bar size is compensated for in the unique joint-stack design.

**Important:** Before ordering reducers, check requirements of Article 364 of the National Electrical Code.

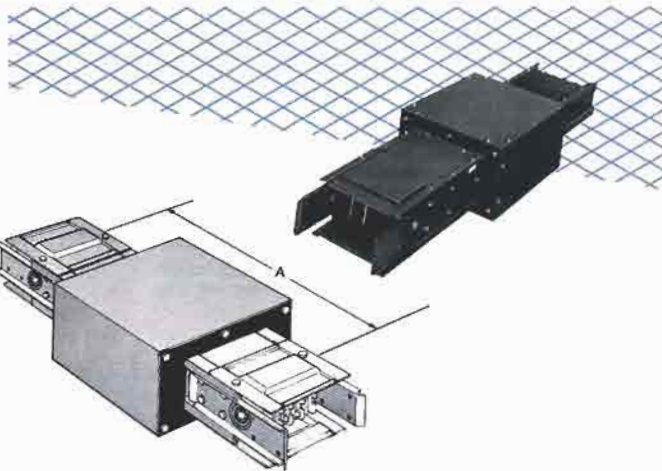

Dimensions (In Inches)	
Largest Casing Size	"A"
4½ x 10	3'-4"
5½ x 10	
7½ x 10	
9½ x 10	
7½ x 20½	4'-0"
9½ x 20½	

The length dimensions shown are minimum and may be increased to include the odd inch dimensions of the run.

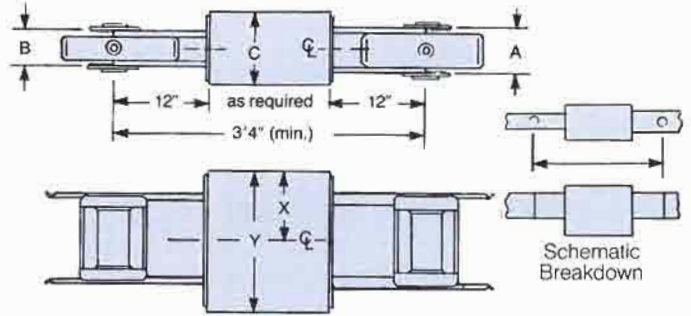

Reducers are available as follows:

Dimensions (In Inches)			From (A)	To (B)	C
Box	"X"	"Y"	5½	4½	8
3 Pole	7	14	7½	5½, 4½	12
4 Pole	9	18	9½	7½, 5½, 4½	

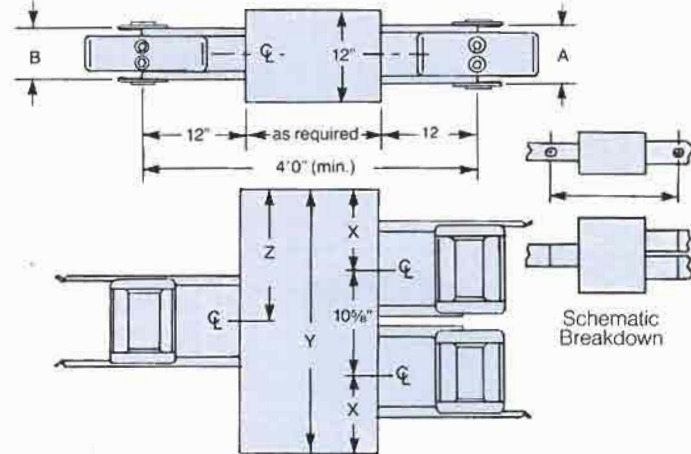

Reducers are available as follows:

Dimensions (In Inches)				From (A)	To (B)
Box	"X"	"Y"	"Z"	7½	4½, 5½, 7½, 9½
3 Pole	7	24½	7 to 17½	9½	4½, 5½, 7½, 9½
4 Pole	9	28½	9 to 19½		

**Note:** All reducers are furnished with joint-stacks assembled on both ends.

### Expansion Sections

XL-U busway expansion sections are designed to be used in busway runs installed where there are building expansion joints. They contain a sliding section with flexible connectors which provide a two-inch, plus-or-minus, adjustment sufficient to handle any building expansion and contraction. They are not required to compensate for differential expansion between bus bar and casing which is provided for in the design of XL-U busway.

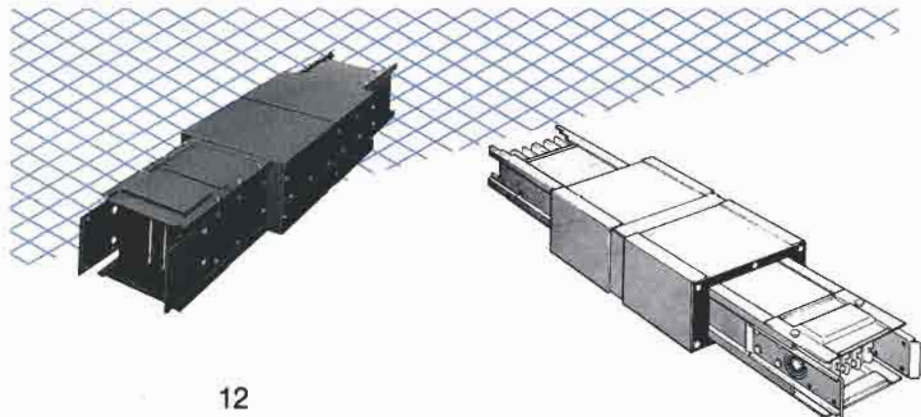

# XL-U<sup>®</sup> Busway Connections

## Flanged End Connections

Flanged end connections are encased bus bar extensions used to connect XL-U busway switchboards or panelboards. Standard stubs extend 12 inches above top of switchboard. The unit includes an end-flange plate for attaching the casing to the panelboard or switchboard and a joint-stack assembly for connecting to bus bars in the XL-U busway run.

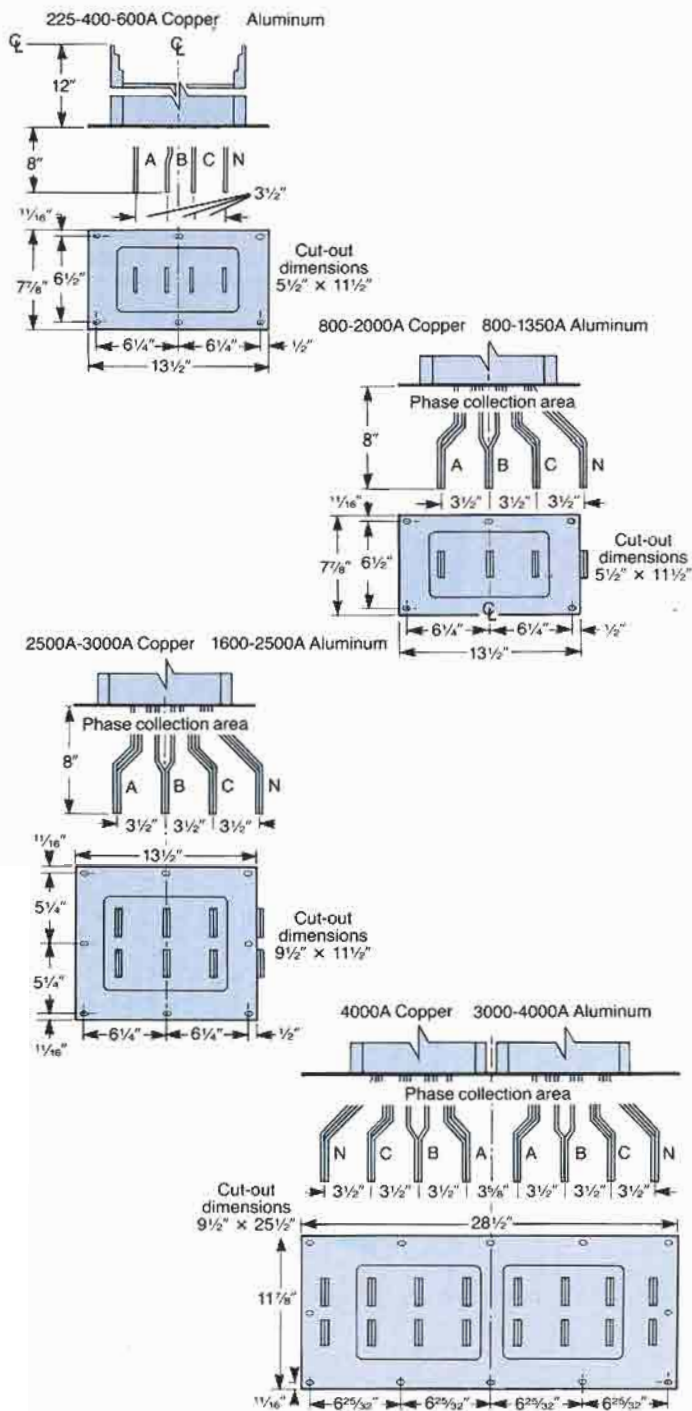

## Drilling Details

The table and drawings shown here provide drilling details for both copper and aluminum bus in flanged-end connections of different ampere ratings. Busway ampere ratings are based on the bars being mounted edgewise.

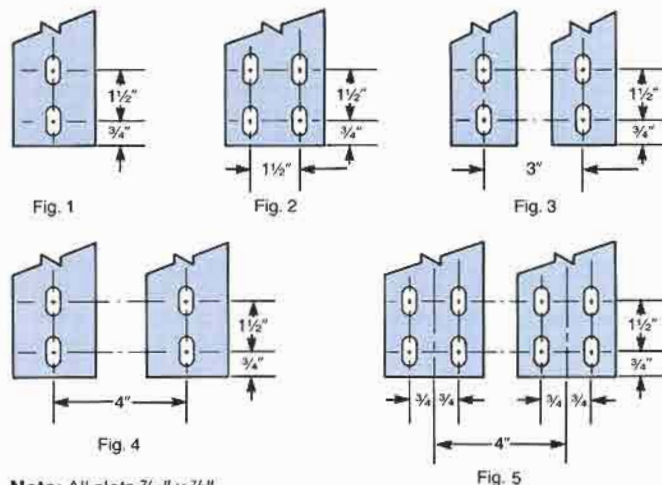

Note: All slots  $\frac{7}{16}'' \times \frac{7}{8}''$

Number of Bars Per Pole	Bus Bar Width		
	1"-1 1/2"-2"	2 1/4"	3"
1 or 2	Fig. 1	Fig. 1	Fig. 2
4 or 8	Fig. 3	Fig. 4	Fig. 5

## Switchboard Connections

XL-U busway prefabricated switchboard connections offer an economical, time-saving method of connecting switchboards and panelboards directly to the busway run. Each standard section includes 12-inches of busway, a bus bar extension with or without lugs, a joint-stack assembly on the busway and a bolt-on flange plate that fastens the casing to a switchboard or panelboard enclosure. Detailed drawings including dimensions for spacing, clearances and bus bar drilling may be obtained from your sales office.

# XL-U® Busway

## Bus Plugs

### Fusible Vacu-Break® Switch And Plug-In Circuit Breaker Plugs—Floor Operable

Key to much of the convenience, flexibility and economy built into the XL-U busway system is the full line of standard and specialized bus plugs available with ratings up to 1200 amperes. XL-U busway plugs act as "instant" power feeds that can be installed at two-foot intervals along the entire plug-in section of a run.

Each plug contains connecting fingers which contact the power, neutral and ground conductors and provide full circuit breaker or fusible protection for an individual branch circuit load. These are mounted in a rigid, steel enclosure provided with suitable knockouts for cable or conduit connections. An interlock system designed into both bus plugs and plug-in openings minimizes danger to personnel and equipment when plugs are added to or removed from the system.

Most XL-U busway bus plugs are completely self-supporting and require only a screwdriver for installation or removal. They can be exchanged, added or removed at any time, providing a simple method for matching power feeds to changing load requirements.

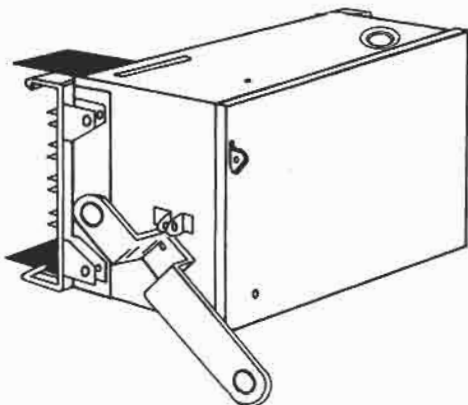
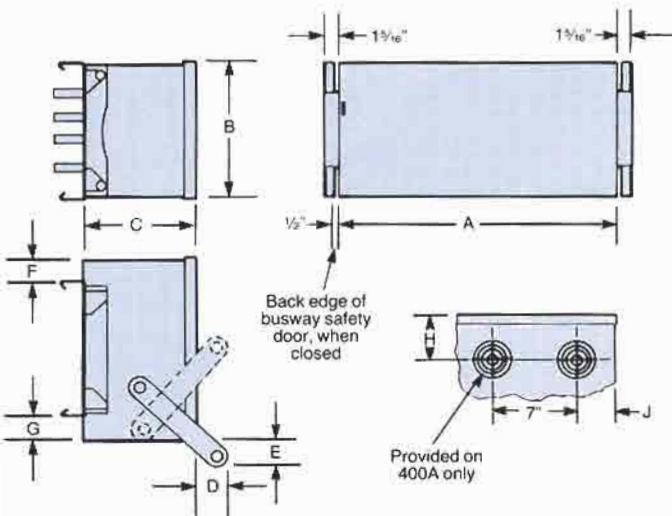

Plugs rated 400 amperes or less require a single plug-in opening. 600 or 800 ampere plugs utilize two openings and 1000-1200 ampere plugs require three plug-in openings. For ratings through 400 amperes, five plugs can be mounted on each side of a ten-foot section of plug-in busway.

All plugs are floor operable by a rope, chain, or hook stick. They include an interlock which prevents plug installation or removal when the plug is in the "ON" position. Red and green flags appear in the inspection port to provide positive identification from the floor. The handle is located at the end of the plug so that it retains control of the switch mechanism regardless of whether the cover is open or shut. Also, the cover contains an interlock to prevent it from being opened with the switch "ON."

The XL-U busway fusible Vacu-Break® plugs are horsepower rated, of the quick-make, quick-break type. Contacts are fully enclosed to minimize arcing and prevent pitting or beading of line and load contacts. Plugs are available with ratings from 30 to 600 amperes for either 250 or 600 volts. Plug-in circuit breaker plugs are available with ratings from 100 to 1200 amperes.

Fusible Vacu-Break Switch Plug

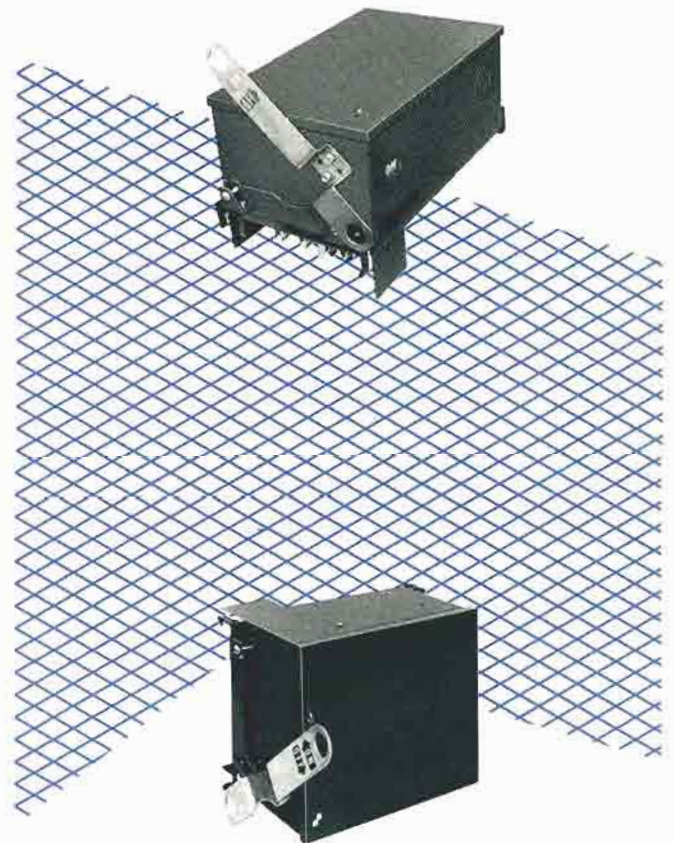

Circuit-Breaker Plug

### Circuit Breaker Plugs—Floor Operable

Breaker Type	Ampere Rating	Dimensions (In Inches)										Lug Size	Plug
		"A"	"B"	"C"	"D"	"E"	"F"	"G"	"H"	"J"	Conduit Size (KO's)		
ED2, ED4, ED6	100	13 <sup>3</sup> / <sub>16</sub>	10 <sup>7</sup> / <sub>8</sub>	7 <sup>7</sup> / <sub>16</sub>	1 <sup>1</sup> / <sub>2</sub>	1 <sup>3</sup> / <sub>8</sub>	0-	3 <sup>8</sup> / <sub>16</sub>	3 <sup>1</sup> / <sub>8</sub>	2 <sup>1</sup> / <sub>8</sub>	3 <sup>1</sup> / <sub>8</sub> , 1, 1 <sup>1</sup> / <sub>4</sub> , 1 <sup>1</sup> / <sub>2</sub> , 2	①	UEC
FD6	250	20 <sup>7</sup> / <sub>16</sub>	10 <sup>7</sup> / <sub>8</sub>	7 <sup>7</sup> / <sub>16</sub>	5 <sup>5</sup> / <sub>8</sub>	2 <sup>1</sup> / <sub>8</sub>	0-	3 <sup>8</sup> / <sub>16</sub>	3 <sup>1</sup> / <sub>8</sub>	3 <sup>1</sup> / <sub>8</sub>	3 <sup>8</sup> / <sub>16</sub> , 1, 1 <sup>1</sup> / <sub>4</sub> , 1 <sup>1</sup> / <sub>2</sub> , 2, 2 <sup>1</sup> / <sub>2</sub>	②	UFC
JXD2, JXD6, JD6	400	21	17 <sup>3</sup> / <sub>16</sub>	10 <sup>5</sup> / <sub>8</sub>	2 <sup>1</sup> / <sub>8</sub>	—	2 <sup>1</sup> / <sub>16</sub>	3 <sup>1</sup> / <sub>16</sub>	—	—	No KO's Provided	③	U6C
LXD6, LD6	600	34 <sup>3</sup> / <sub>4</sub>	15	12 <sup>3</sup> / <sub>8</sub>	3 <sup>3</sup> / <sub>16</sub>	1 <sup>1</sup> / <sub>8</sub>	4 <sup>7</sup> / <sub>8</sub>	4	—	—	No KO's Provided	④	ULC
MD6	800	34 <sup>3</sup> / <sub>4</sub>	15	12 <sup>3</sup> / <sub>8</sub>	3 <sup>3</sup> / <sub>16</sub>	1 <sup>1</sup> / <sub>8</sub>	4 <sup>7</sup> / <sub>8</sub>	4	—	—	No KO's Provided	④	UBC

### Current Limiting Plugs—Floor Operable

Frame Size	Ampere Rating	Dimensions (In Inches)										Lug Size
		"A"	"B"	"C"	"D"	"E"	"F"	"G"	"H"	"J"	Conduit Size (KO's)	
CLE	100	17 <sup>7</sup> / <sub>8</sub>	10 <sup>7</sup> / <sub>8</sub>	7 <sup>5</sup> / <sub>8</sub>	1 <sup>1</sup> / <sub>2</sub>	1	2 <sup>3</sup> / <sub>16</sub>	2 <sup>1</sup> / <sub>32</sub>	—	3	1/2, 3/4, 1, 1 <sup>1</sup> / <sub>4</sub> , 1 <sup>1</sup> / <sub>2</sub> , 2	①
CLF	225	26 <sup>1</sup> / <sub>8</sub>	10 <sup>7</sup> / <sub>8</sub>	7 <sup>5</sup> / <sub>8</sub>	4 <sup>1</sup> / <sub>2</sub>	3 <sup>1</sup> / <sub>2</sub>	2 <sup>3</sup> / <sub>16</sub>	2 <sup>1</sup> / <sub>32</sub>	—	3	3/4, 1, 1 <sup>1</sup> / <sub>4</sub> , 1 <sup>1</sup> / <sub>2</sub> , 2, 2 <sup>1</sup> / <sub>2</sub>	②
CJ	400	22 <sup>1</sup> / <sub>8</sub>	17 <sup>3</sup> / <sub>16</sub>	10 <sup>5</sup> / <sub>8</sub>	1	—	5 <sup>7</sup> / <sub>16</sub>	6 <sup>1</sup> / <sub>16</sub>	—	—	No KO's Provided	⑤
CM	800	39 <sup>1</sup> / <sub>4</sub>	15	12 <sup>3</sup> / <sub>8</sub>	3 <sup>3</sup> / <sub>16</sub>	1 <sup>1</sup> / <sub>8</sub>	4 <sup>7</sup> / <sub>8</sub>	4	—	—	No KO's Provided	⑥

- ① 10-30A (1) #14-#8 AWG Cu/Al (JXD6, JD6) 400A (2) 3/0 AWG-250 MCM Cu/Al  
 (1) #12-#8 AWG Cu/Al 250-350A (1) 250-500 MCM Cu/Al  
 35-100A (1) #8-1/0 AWG Cu/Al (1) 350-500 MCM Cu/Al  
 (1) #6-1/0 AWG Cu/Al 400A (2) 3/0 AWG-250 MCM Cu/Al  
 (2) 4/0 AWG-250 MCM Cu/Al
- ② 225A (1) #4 AWG-350 MCM Cu/Al (1) #6 AWG-350 MCM Cu Only  
 ④ 250-600A (2) #1 AWG-500 MCM Cu/Al  
 700-800A (3) 300-350 MCM Cu/Al  
 (3) 400 MCM Cu/Al
- ③ (JXD2)  
 125-225A (1) #4 AWG-300 MCM Cu/Al  
 (1) #2 AWG-300 MCM Cu/Al  
 250-350A (1) 250-500 MCM Cu/Al  
 (1) 350-500 MCM Cu/Al  
 400A (2) 3/0 AWG-250 MCM Cu/Al  
 4/0 AWG-250 MCM Cu/Al
- ⑤ 125-225A (1) #4 AWG-300 MCM Cu/Al  
 (6) #2 AWG-300 MCM Cu/Al  
 250-350A (1) 250-500 MCM Cu/Al  
 (1) 350-500 MCM Cu/Al
- ⑥ 400A (2) 3/0 AWG-250 MCM Cu/Al  
 (2) 4/0 AWG-250 MCM Cu/Al  
 ⑥ 400-600A (2) #1 AWG-350 MCM Cu/Al  
 700-800A (3) 300-400 MCM Cu/Al  
 (3) 350-400 MCM Cu/Al

**Note:** These charts show the family size of breakers that can be used in each enclosure. Other breakers may be used if their physical size matches that of these families.

**Note:** For short circuit rating on circuit breakers consult Siemens' Speedfax.

### Fusible Vacu-Break® Switch Plugs—Floor Operable

Ampere Rating	Dimensions (In Inches)										Lug Size
	"A"	"B"	"C"	"D"	"E"	"F"	"G"	"H"	"J"	Conduit Size (KO's)	
30	12 <sup>3</sup> / <sub>8</sub>	10 <sup>9</sup> / <sub>16</sub>	7 <sup>1</sup> / <sub>2</sub>	4 <sup>3</sup> / <sub>8</sub>	4	0	3 <sup>8</sup> / <sub>16</sub>	3 <sup>1</sup> / <sub>8</sub>	3	1/2, 3/4, 1, 1 <sup>1</sup> / <sub>4</sub> , 1 <sup>1</sup> / <sub>2</sub> , 2	①
60											②
100	16 <sup>1</sup> / <sub>2</sub>	10 <sup>9</sup> / <sub>16</sub>	7 <sup>1</sup> / <sub>2</sub>	4 <sup>1</sup> / <sub>2</sub>	4	0	3 <sup>8</sup> / <sub>16</sub>	3 <sup>1</sup> / <sub>8</sub>	3	3/4, 1, 1 <sup>1</sup> / <sub>4</sub> , 1 <sup>1</sup> / <sub>2</sub> , 2, 2 <sup>1</sup> / <sub>2</sub>	③
200	20 <sup>1</sup> / <sub>8</sub>										④
400	20 <sup>3</sup> / <sub>16</sub>	16 <sup>1</sup> / <sub>16</sub>	10 <sup>5</sup> / <sub>8</sub>	9	0	2 <sup>1</sup> / <sub>16</sub>	3 <sup>1</sup> / <sub>16</sub>	6 <sup>3</sup> / <sub>8</sub>	3 <sup>3</sup> / <sub>4</sub>	3, 3 <sup>1</sup> / <sub>2</sub> , 4	⑤
600	33 <sup>3</sup> / <sub>4</sub>	14 <sup>5</sup> / <sub>8</sub>	12 <sup>3</sup> / <sub>8</sub>	9	0	2 <sup>1</sup> / <sub>16</sub>	1 <sup>5</sup> / <sub>8</sub>	—	—	No KO's Provided	⑥

- ① (1) #14-4 AWG Cu/Al
- ② (1) #14-2 AWG Cu/Al
- ③ (1) #14-1/0 AWG Cu/Al
- ④ (1) #6 AWG-250 MCM Cu/Al
- ⑤ (1) #4 AWG-500 MCM Cu/Al
- (1) #6 AWG-250 MCM Cu/Al
- ⑥ (2) #4 AWG-500 MCM Cu/Al

### Ground-Detector And Potentializer Plugs

These XL-U busway plugs provide a simple way to detect grounds in ungrounded systems. In addition, they establish a potential to ground between bus bars and casings for ungrounded systems. Lamps mounted on the cover provide visual indication of grounds in the distribution system by displaying an unbalance in the brightness.



# XL-U® Busway

Bus Plugs—continued

## Combination Motor-Starter Plugs—Floor-Operated

XL-U busway combination motor-starter plugs provide a simple way to install motor starter and protective devices close to the load. They are available with Siemens non-reversing motor starters in NEMA Size 0, 1 or 2. Disconnects can be quick-make, quick-break fusible switches or ETI instantaneous-trip circuit breakers, operated from the floor with a rope, chain or hook stick. Plugs for remote switching of lighting loads are also available.

Starter Size	Dimensions (In Inches)			KO Size
	"A"	"B"	"C"	
0 1 2*	16½	10¾	7½	½, ¾, 1, 1¼, 1½, 2

\*Fusible 480V plug with Size 2 starter takes larger enclosure. Contact sales office.



## Capacitor Plugs—Floor-Operated

XL-U busway capacitor plugs offer a convenient way to reduce inductive reactance and improve the power factor on plug-in busway runs. Capacitor plugs are available in 5 or 7½ KVAR at 240 volts, 5-15 KVAR at 480 or 600 volts, with either circuit breaker or Vacu-Break® fusible-switch disconnect. They are easy to operate from the floor with a rope, chain or hook stick.

## Transformer Plugs—Floor-Operated

XL-U busway transformer plugs supply simple-phase current at reduced voltages of 240 or 120 volts for minor loads, such as lighting receptacles, small motors, portable tools, etc. Rated to 10 KVA, they are available with either circuit breaker or Vacu-Break® fusible-switch protection. Optional contactors permit remote pushbutton switching of the transformer. Plugs can be operated from the floor with a rope, chain or hook stick.

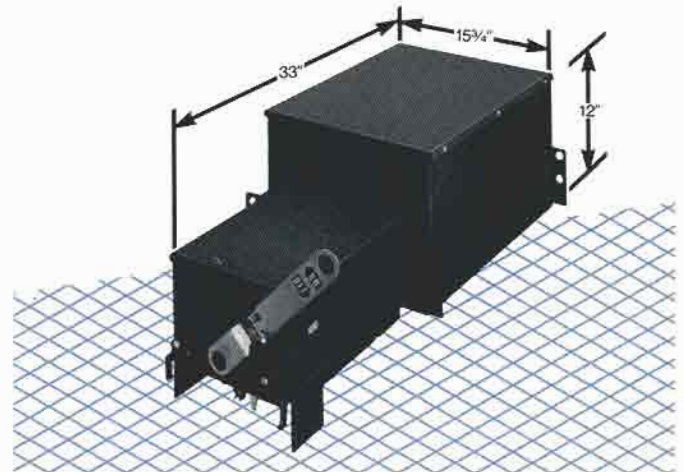

## Cubicles

A wide range of cubicles is available—each a prefabricated compartment containing a fuse and switch combination or circuit-breaker device used to protect the main service of busway or an individual branch circuit. Supplied with or without provision for adding a branch run, they may be installed readily at a busway joint connection or the end of a busway run. Provision has been made for suspending each cubicle from standard supporting rods. The table shows dimensions for some of the most frequently used cubicles.

Max. Rating Amperes	Type of Protective Device	Dimensions† (In Inches)			
		"A"	"B"	"C"	"D"
400	Switch and Fuse JXD2 or JXD6 Breaker CJ Breaker and Fuse	28	30	16	
600	Switch and Fuse K-600 LV Power Breaker			30	16
800	Switch and Fuse MD6 Breaker CM Breaker and Fuse	32	38	40	16
			28	30	16
			28	36	18
1200	Switch and Fuse ND6 Breaker	38	40	16	
1600	HP Breaker CP Breaker and Fuse K-1600 LV Power Breaker	32	28	30	16
			38	50	16
			38	40	22
2000	HR Breaker CR Breaker and Fuse K-2000 LV Power Breaker	32	28	30	16
			38	50	16
			38	40	22

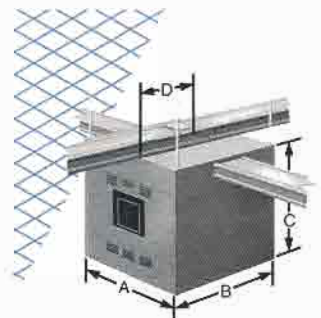

† Figures shown are maximum dimensions for most frequently used busway arrangements. Smaller dimensions are available for special cubicle applications. Contact sales office.

# XL-U® Busway

## Installation

### Quick and Easy

Every component of the XL-U busway system was designed for quick, easy installation. A screwdriver and socket wrench are the only tools required. The unique XL-U busway joint-stack design in both busway sections and fittings reduces installation time for the most complicated layouts.

Tap boxes or cubicles can be installed in minutes at any busway joint; and any bus plug can be installed simply by hanging it over a convenient plug-in opening.

The following information gives brief instructions for some of the more frequently encountered installation operations.

### Instructions For Assembling A Busway Joint-Stack

Joint-stack A has been factory installed on one end of each busway section or fitting. Splice plates B, which hold the stack in place, have also been factory assembled on the same busway end. Joint cover plates C, also installed at the factory, do not have to be removed during installation.

If installation conditions should require it, the entire joint-stack assembly, A, splice plates, B, and cover plates, C, may be removed and installed at the opposite end of any section.

Standard fittings, such as elbows, tees and end-tap boxes, may be installed in the same manner as busway sections.

1. Slide, or telescope, plain bar end into joint-stack until holes D line up with holes E.
2. Bolt splice plates to busway casing through holes D and E with eight 1/4-20 screws provided.
3. Tighten joint bolt F on joint-stack A. Apply 35 foot-pounds of torque, with torque wrench.
4. If busway is equipped with ground bus, install 3/8-16 inch bolt and washer provided through hole G in the splice plate.

**Note:** Do not mount nameplate side of busway toward ceiling or plugs will be upside down.

### Instructions For Hanging Busway

Standard prefabricated, clamp-type hangers and rod-hanger adaptors make it quick and easy to hang XL-U busway in any way required by building construction. No on the job drilling, bending or cutting is required. One hanger is supplied with each busway section and fitting. Additional hangers and adaptors (UJ100) may be ordered if desired. Busway runs can normally be hung on ten-foot centers.

1. Slip hanger over the busway casing, position to match supporting arrangement and bolt tight. No need to bolt or screw the hanger to the casing.
2. The most frequent method of suspension uses standard drop rods cut to length and fastened to building structure. See diagram page 9. Bolt rod-hanger adaptor X to rod Y through hole H. When busway is hung flatwise, one support for each hanger is sufficient. When hung edgewise, two supports may be required for greater rigidity, particularly for higher-ampere busway.
3. Lift busway into position and slip bolt previously inserted through hole P into slot in adaptor. Where two-point suspension is required, loosen bolts N at corners of hanger and slip into slots of corresponding adaptors.
4. Tighten bolts firmly to retain hanger in position on adaptor(s). Hangers may easily be removed from adaptors if busway must be relocated.

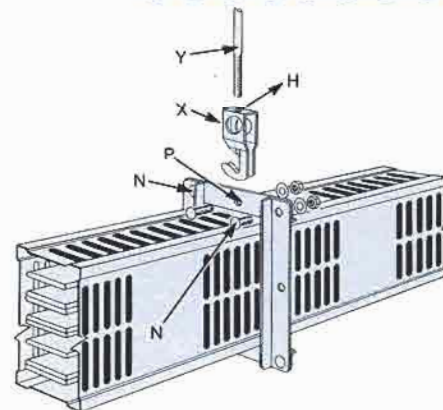
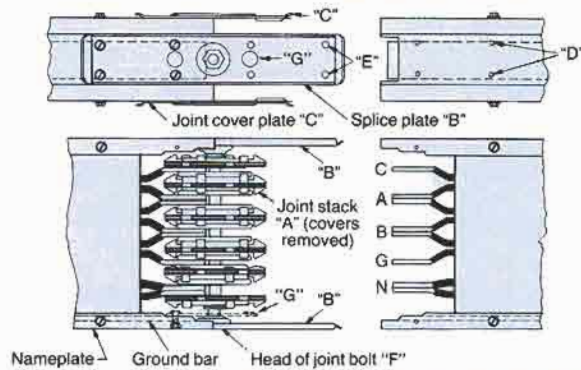

## Instructions For Installing And Removing Bus Plug

Bus plugs may be installed and removed in seconds using only a screwdriver. The XL-U busway built-in interlock system provides protection to personnel and equipment at all times.

### Installing Plug

1. Be sure safety door **V** over plug-in opening is closed, bus-plug switch is in "OFF" position and cover is closed.
2. Back off clamp screws **Q** of three rotating clamps **R** on both sides of plug.
3. Hook plug on busway using single non-rotating clamp **NR** on far end of plug and position over opening.
4. Insert non-metallic safety interlock key **K** into slot **W** in safety door **V** and push in plug until it stops.
5. Open door **V**, then push plug all the way in against busway.
6. Tighten screws **Q** firmly on both sides of plug. This closes the rotating clamps **R** which then hold the plug firmly in position on the busway.

### Removing Plug

1. Be sure switch handle is in "OFF" position and the bus-plug cover is closed.
2. Back off clamp screws **Q** of three rotating clamps **R** on both sides of plug and open out all three clamps.
3. Swing switch or handle end of plug away from busway until it stops.
4. Close safety door **V** over plug-in opening and remove plug completely.

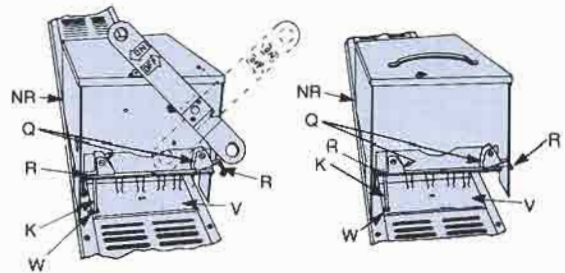

## Instructions For Removing Section From Busway Run

Joint-stack **A**, splice plates **B** and cover plates **C** may be removed easily before or after installation. This makes it possible to remove or replace a busway section from an existing de-energized run without disturbing adjacent sections. It also allows installation of busway sections from any angle in restricted spaces where the usual seven-inch telescoping motion is not possible.

1. Loosen joint bolt **F**—but do not remove it—in joint at both ends of busway section to be removed.
2. Remove all four splice plates **B**.
3. Remove two front joint-covers **C**.
4. Slide out both joint-stacks **A**.
5. Busway section may be removed horizontally, as shown, or dropped out vertically.
6. To install replacement section, reverse the procedure above.

**Note:** Section being removed should be supported at two locations before steps, 2, 3 and 4 are taken.

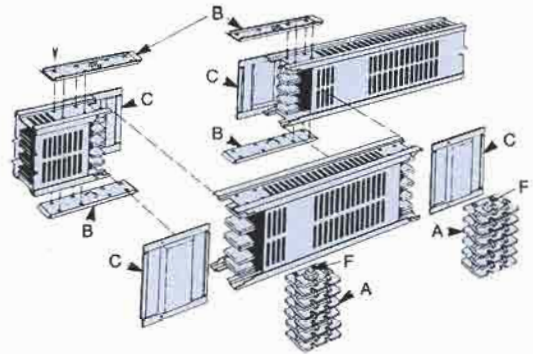

### Instructions For Installing A Center-Cable Tap Box

A tap box, cubicle or other device may be attached to any de-energized joint connection during original installation or at any time afterwards. This allows maximum flexibility in tapping off power to meet changing load requirements. Branch runs during original installation are usually handled by tees or crosses which are connected in the same manner as busway sections described above. End-cable tap boxes are also connected like busway sections.

1. Remove one of the joint splice plates **B** and replace it with one of the angles **S** furnished with the tap box.
2. Replace the other splice plate **B** in the same manner.
3. Remove the joint cover plate **C** from the side where the tap box is to be installed.
4. Loosen the joint bolt **F**, but do not remove it.
5. Remove the entire joint-stack assembly **A**.
6. Install tap box with factory-assembled tap stack **T**.
7. Replace splice plates **B** and discard the angles which supported the busway sections during joint-stack exchange.
8. Tighten the joint bolt **F** to a torque of 30-35 foot-pounds.
9. Loosen the clamp screws **Q** within the four rotating clamps **R** on both sides of the tap-box enclosure. This opens out the clamps.
10. Position the enclosure around the tap stack and tighten the clamp screws **Q**, fastening the enclosure firmly to the busway casing.

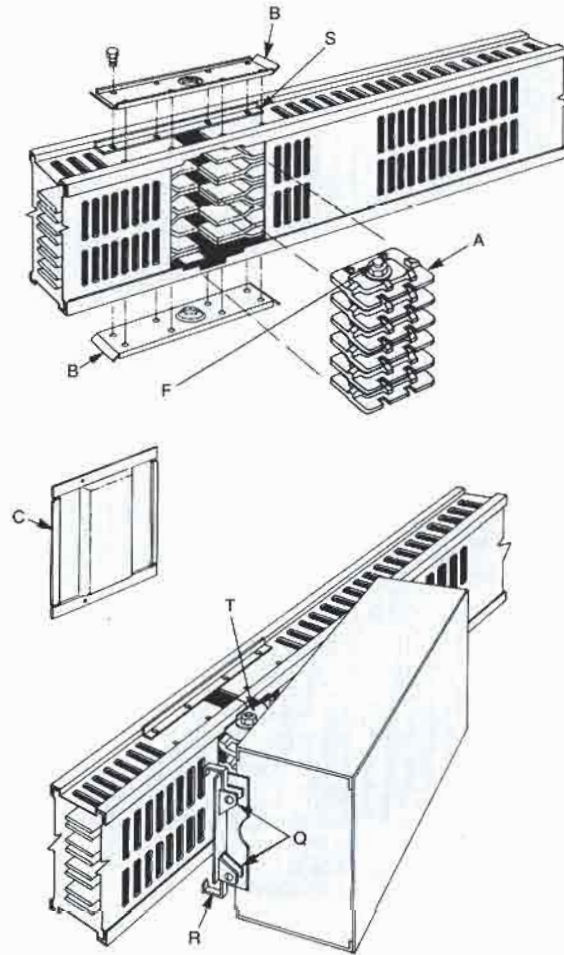

# XL-U® Busway

## Voltage Charts

### Voltage Drop—Plug-In or Feeder Busway

3 Phase, Line-to-Line Drop per 100 Feet, at Rated Current with Distributed Loading

#### Aluminum Conductors

Busway Capacity Amperes	Voltage Drop by % Load Power Factor—Volts*										
	100	90	80	70	60	50	40	30	20	10	0
225	1.33	1.53	1.62	1.64	1.62	1.58	1.52	1.44	1.35	1.25	1.17
400	1.28	1.84	1.99	2.03	2.04	2.03	2.02	1.99	1.92	1.82	1.70
600	1.26	2.10	2.40	2.48	2.53	2.53	2.52	2.49	2.43	2.37	2.25
800	1.85	2.05	2.00	1.92	1.80	1.68	1.53	1.38	1.21	1.04	.88
1000	1.85	2.02	1.98	1.89	1.77	1.65	1.50	1.35	1.19	1.08	.87
1200	1.68	1.87	1.91	1.85	1.76	1.65	1.53	1.40	1.25	1.09	.94
1350	1.65	1.83	1.82	1.76	1.67	1.57	1.44	1.32	1.18	1.03	.89
1600	1.72	1.91	1.87	1.80	1.71	1.58	1.46	1.30	1.16	1.00	.84
2000	1.72	1.92	1.88	1.79	1.69	1.58	1.46	1.31	1.17	1.01	.86
2500	1.60	1.78	1.75	1.71	1.61	1.53	1.41	1.28	1.13	.99	.83
3000	1.62	1.80	1.77	1.69	1.61	1.48	1.35	1.23	1.08	.95	.78
4000	1.52	1.76	1.70	1.60	1.54	1.40	1.26	1.18	1.02	.88	.76
5000	1.55	1.75	1.75	1.73	1.67	1.55	1.45	1.30	1.15	.98	.80

#### Copper Conductors

Busway Capacity Amperes	Voltage Drop by % Load Power Factor—Volts*										
	100	90	80	70	60	50	40	30	20	10	0
225	1.74	2.10	2.08	2.07	1.99	1.87	1.78	1.64	1.50	1.33	1.12
400	1.00	1.70	1.91	2.07	2.12	2.17	2.18	2.17	2.12	2.08	1.99
600	1.20	2.25	2.55	2.55	2.77	2.86	2.85	2.85	2.78	2.70	2.49
800	1.64	1.90	1.91	1.88	1.81	1.72	1.61	1.50	1.37	1.23	1.08
1000	1.37	1.62	1.66	1.64	1.60	1.53	1.46	1.37	1.27	1.16	1.04
1200	1.65	1.94	1.98	1.97	1.92	1.84	1.75	1.64	1.52	1.39	1.25
1350	1.42	1.75	1.78	1.78	1.74	1.68	1.61	1.51	1.40	1.28	1.16
1600	1.29	1.62	1.69	1.69	1.66	1.61	1.54	1.46	1.37	1.26	1.18
2000	1.40	1.79	1.88	1.89	1.84	1.79	1.71	1.62	1.52	1.40	1.29
2500	1.23	1.53	1.60	1.56	1.53	1.49	1.41	1.34	1.24	1.12	1.02
3000	1.23	1.55	1.62	1.62	1.56	1.51	1.46	1.35	1.26	1.17	1.03
4000	1.20	1.46	1.56	1.58	1.56	1.46	1.40	1.34	1.20	1.10	.98
5000	1.20	1.52	1.55	1.55	1.52	1.48	1.42	1.30	1.20	1.07	.97
6000	1.20	1.53	1.56	1.59	1.56	1.53	1.47	1.38	1.26	1.17	1.02
6500	1.11	1.46	1.56	1.59	1.56	1.49	1.40	1.30	1.24	1.04	.94

\*Values for non-ventilated busway 225-600A and ventilated edge-wise mounted busway 800A and higher.

# XL-U® Busway

## Typical Specifications

Electrical contractor shall furnish and install a complete system of interconnected busway runs as shown on the plans and in accordance with local and national code regulations. Busway sections shall bear the Underwriters Laboratories, Inc. label.

Casing ends shall be identical to minimize the number of fittings required and to permit installation from any direction—front, side or in a telescoping manner. A splice plate shall be furnished at each joint connection to join the casings mechanically. The busway shall require access from *only two sides* to complete bus bar and housing connections. Splice plates and casing assemblies shall be rigid enough for supporting on ten-foot centers. Hangers shall be provided by busway manufacturer.

Joint assemblies shall be accomplished by means of an insulated bolt passing through the conductors. Joint integrity shall not be affected by deforming the casing. Inspection shall be provided on each side of the joint-stack and shall be usable without disturbing the joint pressure or voiding the Underwriters ten-foot support tests. The joint design shall permit a removal of sections in the middle of a run without the use of jacking tools and without disturbing adjacent sections. It shall be possible to add center-tap boxes or cubicles at any point in either a feeder or a plug-in busway run without removing a busway section.

Bus bars shall be fabricated from electrical grade (copper) (aluminum) and shall be supported so that the assembly is capable of withstanding specified short-circuit currents. All joint surfaces and plug-in locations shall be silver finished. Plug-in and feeder sections shall be interchangeable.

Bus bars rated 800 ampere or greater shall be insulated\* for their entire length, except at plug-in locations, with a continuous coating of 105°C insulation. They shall be independently supported on high-strength, glass-filled polyester insulators and shall not rely on the busway housing for support.

Plug-in openings shall be spaced on 24-inch centers along both sides of the busway and across the joints. Plug-in openings shall be of the interlocking type and, in conjunction with the plug, shall assure the following:

1. The act of installing or removing a bus plug shall originate and conclude with the plug-in opening cover firmly closed.
2. Interlocks shall be provided which prevent insertion or removal of the bus plug when its switching mechanism is in the "ON" position.
3. Metal parts of the plug shall contact the steel casing before the plug fingers contact the bus bars.
4. A continuous ground conductor shall be provided inside the busway casing to offer a low-impedance ground path. Each bus plug shall be provided with a non-ferrous grounding conductor for cable termination and connection to busway grounding conductor. Busway runs and fittings shall be of the XL-U busway type as manufactured by the Electrical Apparatus Division of Siemens Energy & Automation, Inc.

\*Busways rated 600 ampere or less are uninsulated unless specifically requested.