

Cable Accessories

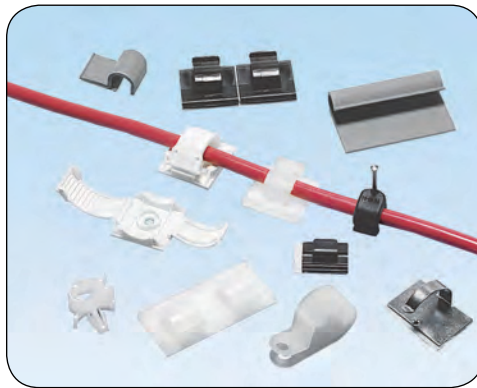

Panduit® provides a comprehensive offering of cable accessories. These accessories are engineered to speed installation and lower installed costs for routing and managing cable. Panduit cable accessories are designed and manufactured to meet applicable quality standards including International, UL, Military, ISO and Aerospace.



- Largest selection of mounts, clips, and clamps for cable management
- Panduit cable ties and accessories can be used in a variety of applications and environments, providing the optimal cable management solution
- Installation methods include adhesive backed, user applied adhesive, screws, rivets or push barb



Panduit mounts, clips, and clamps are manufactured in an environment committed to design innovation, high quality, and knowledgeable service to our customers. Adhesive backed mounts provide a strong adhesive bond for long-term reliability. Cable clips offer a one-piece solution to save time and reduce inventory. Harness board accessories speed the routing and forming of cable bundles in the fabrication of a harness. They hold bundles at a uniform height above the board and are ideal for use with Panduit manual and automatic cable tie tooling.

Cable Accessories Products Overview – Used with Cable Ties

Adhesive Backed Cable Tie Mounts

Pages B2.4 – B2.8



- Uses premium Panduit adhesive for a long-term, reliable bond
- Adhesive backing allows routing of wires and cables where mounting holes cannot be drilled
- Mounts should be used with Panduit cable ties for a complete wire routing solution

Screw Applied Cable Tie Mounts

Pages B2.9 – B2.15



- Screw/rivet applied cable tie mounts offer a countersunk or through hole in the mount through which a screw or rivet can be secured
- Offered in a wide selection of specialty materials for resistance to severe conditions such as heat, radiation, chemicals, and outdoor environments
- Available in styles ranging from low profile mounts with integral push-rivet to high stability cradle mounts for Extra-Heavy strength cable ties

Other Cable Tie Mounts

Pages B2.16 – B2.26



- Push mount designs lock into a hole in a metallic panel or in a blind masonry hole
- Edge clip mounts secure to a panel edge using metal barbs that dig into panel surface
- Stud mounts secure onto threaded bolts by screwing or hammering on the bolt
- Connector rings can be used to attach adjacent bundles to provide spacing and prevent vibration damage

Super-Grip™ Adhesive Backed Cable Tie Mounts

- Low profile design keeps bundle close to mounting surface
- Small overall size allows use where space is limited
- For use with Super-Grip™ Cable Ties found on page B1.36
- High Bond Adhesive available

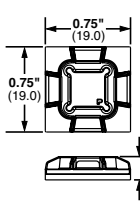
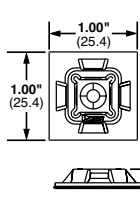
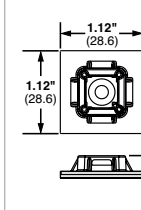
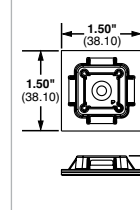
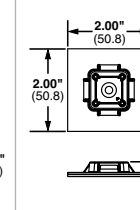

	 SGABM20 0.75" x 0.75"	 SGABM25 1.00" x 1.00"	 SGABM30 1.12" x 1.12"	 SGABM40 1.50" x 1.50"	 SGABM50 2.00" x 2.00"
	Accepts SGM, SGI Cable Ties	Accepts SGM, SGI, SGS Cable Ties	Accepts SGM, SGI, SGS Cable Ties	Accepts SGM, SGI, SGS, SGLH, SGH Cable Ties	Accepts SGM, SGI, SGS, SGLH, SGH Cable Ties
White Nylon 6.6; Rubber Adhesive; Indoor Environment	SGABM20-A-C 100 pc/pkg	SGABM25-A-C 100 pc/pkg	SGABM30-A-C 100 pc/pkg	SGABM40-A-L 50 pc/pkg	SGABM50-A-L 50 pc/pkg
Black Weather Resistant Nylon 6.6; Acrylic Adhesive; Outdoor/High Temp Environment	SGABM20-AT-C0 100 pc/pkg	SGABM25-AT-C0 100 pc/pkg	SGABM30-AT-C0 100 pc/pkg	SGABM40-AT-L0 50 pc/pkg	SGABM50-AT-L0 50 pc/pkg
Black Weather Resistant Heat Stabilized Nylon 6.6; High Bond Acrylic Adhesive; Outdoor/High Temp Environment	SGABM20-AV-C300 100 pc/pkg	SGABM25-AV-C300 100 pc/pkg	SGABM30-AV-C300 100 pc/pkg	-	-
White Nylon 6.6; Indoor Environment; User Supplied Adhesive or #6 (M3) screw(s)	-	SGABM25-S6-C 100 pc/pkg	-	-	-
Black Weather Resistant Nylon 6.6; Outdoor Environment; User Supplied Adhesive or #6 (M3) screw(s)	-	SGABM25-S6-C0 100 pc/pkg	-	-	-

Combination Adhesive Mount/Cable Ties

- Adhesive mount and cable tie molded as one-piece helps reduce inventory costs
- Available with locking or releasable tie
- For indoor use only
- Material: Nylon 6.6

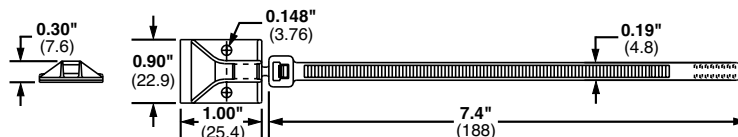

Part Number	Tool	Color	Adhesive Type	Std. Pkg. Qty.	Std. Ctn. Qty.
Locking Cable Tie					
PLA2S-A-Q	GTS, GTSL, GS2B, GS4H, PTS, PTH, PPTS, STS2, STH2	White	Rubber	25	250
Releasable Cable Tie					
PRA2S-A-Q	Hand installed only	White	Rubber	25	250