

THIS COPY IS PROVIDED ON A RESTRICTED BASIS AND IS NOT TO BE USED IN ANY WAY DETRIMENTAL TO THE INTERESTS OF PANDUIT CORP.

PANDUIT PART #	STUD SIZE		DIMENSIONS in. [mm]					CA9 SERIES CRIMP DIE	CA-800(EZ) SERIES CRIMP DIE
	ENGLISH	METRIC	L ± .04 [1,0]	W ± .01 [0,3]	C ± .02 [0,5]	M ± .03 [0,8]	H ± .01 [0,3]		
PNF10-6F-2K	#6	M3,5	1.01 [25,7]	.31 [7,9]	.24 [6,1]	.80 [20,3]	.15 [3,8]	CD9-3B	CD-800-3
PNF10-8F-2K	#8	M4	1.02 [25,9]	.37 [9,4]	.24 [6,1]	.80 [20,3]	.17 [4,3]		
PNF10-10F-2K	#10	--	1.04 [26,4]	.37 [9,4]	.22 [5,6]	.80 [20,3]	.20 [5,0]		
PMNF6-5F-2K	--	M5	1.01 [25,7]	.38 [9,7]	.24 [6,2]	.79 [20,1]	.21 [5,3]		
PNF10-14F-2K	1/4"	M6	1.15 [29,2]	.49 [12,5]	.32 [8,1]	.90 [22,9]	.27 [6,9]		

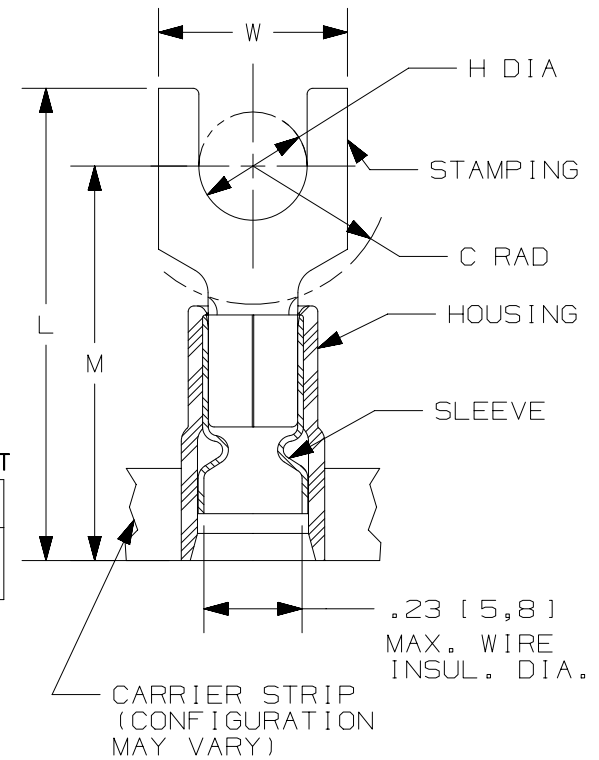

PRESS/APPLICATOR COMPATIBILITY CHART

PRESS	CP-871	CP-861
APPLICATOR	CA9 CA-800EZ	CA-800

NOTES:

- UL LISTED AND CSA CERTIFIED FOR:
 - A. #12-10 AWG [4,0-6,0 mm²] SOLID OR STRANDED COPPER WIRE
 - B. 221°F [105°C] MAX. OPERATING TEMPERATURE
 - C. 600 V. MAX. VOLTAGE RATING
- SEE www.panduit.com FOR PACKAGE QUANTITIES
- MATERIAL:
 - A. STAMPING: .04" [1,0] THK COPPER, TIN PLATED
 - B. HOUSING: VINYL, YELLOW
- DIMENSIONS IN BRACKETS ARE METRIC EQUIVALENT
- WIRE STRIP LENGTH: 1 1/32" ^{+1/32}₋₀ [8,7mm ^{+0,8}₋₀]

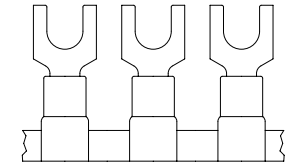

TITLE
FORK TERMINALS, 3 PC. NYLON (FUNNEL) INSULATED, #12-10, CONTINUOUS REEL
 CUSTOMER DRAWING

ITEM REVISION NAME		N41139BA/08		PANDUIT
DATASET FILE NAME		N41139BA_DC/08A		
UNLESS OTHERWISE SPECIFIED, DIMENSIONAL TOLERANCES ARE: IN [mm]				
DRAWN BY		DATE	CHK	SCALE
GRM		-	FS	N.T.S.
DRAWING NUMBER:				A41139
SHT 1 OF 1				A

REV	DATE	BY	CHK	APR	DESCRIPTION	ECN
08	12/16	TMR	TMR	RGB	REVISED CERTIFICATION	N41139BA-A41139
07	06/14	MBY	JHNU	RGB	REVISED NOTES, MOVED TOOLS TO TABLE, REVISED CERTIFICATION	N41139BA-A41139
06	09.07.12	JBN	LCA	VMB	ADDED METRIC EQUIVALENT. REVISED NOTES. UPDATED DRAWING TO CURRENT STANDARDS.	A41139

D10100DA/15