

Inverter

MICROMASTER 440



4/2	Description
4/4	Circuit diagrams
4/6	Technical data
4/9	Selection and ordering data
4/12	Options
4/26	Dimension drawings

MICROMASTER 440

Description



Application

The MICROMASTER 440 inverter is suitable for a variety of variable-speed drive applications. Its flexibility provides for a wide spectrum of applications. These also include cranes and hoisting gear, high-bay warehouses, production machines for food, beverages and tobacco, packaging machines etc.; i.e. applications which require the frequency inverter to have a higher functionality and dynamic response than usual.

The inverter is especially characterized by its customer-oriented performance and ease-of-use. Its large mains voltage range enables it to be used all over the world.

Design

The MICROMASTER 440 inverter has a modular design. The operator panels and modules can be easily exchanged.

International standards

- The MICROMASTER 440 inverter complies with the requirements of the EU low-voltage guideline
- The MICROMASTER 440 inverter has the **CE** marking
- acc. to **®** and **c®** certified
- c-tick **Ⓢ**

Note:

- See Appendix for standards.

Main characteristics

- Easy, guided start-up
- Modular construction allows maximum configuration flexibility
- Six programmable isolated digital inputs
- Two scaleable analog inputs (0 V to 10 V, 0 mA to 20 mA) can also be used as a 7th/8th digital input
- Two programmable analog outputs (0 mA to 20 mA)
- Three programmable relay outputs (30 V DC/5 A resistive load; 250 V AC/2A inductive load)
- Low-noise motor operation thanks to high pulse frequencies, adjustable (observe derating if necessary)
- Complete protection for motor and inverter.

Options (overview)

- EMC filter, Class A/B
- LC filter and sinusoidal filter
- Line commutating chokes
- Output chokes
- Gland plates

- Basic Operator Panel (BOP) for parameterizing the inverter
- Plain text Advanced Operator Panel (AOP) with multi-language display
- Plain text Asian Advanced Operator Panel (AAOP) with Chinese and English display
- Plain text Cyrillic Advanced Operator Panel (CAOP) with Cyrillic, German and English display
- Communication modules
 - PROFIBUS
 - DeviceNet
 - CANopen
- Pulse encoder evaluation module
- PC connection kits
- Mounting kits for installing the operator panels in the control cabinet doors
- PC start-up tools executable under Windows 98 and NT/2000/ME/XP Professional
- TIA integration with Drive ES.

Mechanical features

- Modular design
- Operating temperature
0.12 kW to 75 kW:
-10 °C to +50 °C
(+14 °F to +122 °F)
90 kW to 200 kW:
0 °C to +40 °C
(+32 °F to +104 °F)
- Compact housing as a result of high power density
- Easy cable connection, mains and motor connections are separated for optimum electromagnetic compatibility
- Detachable operator panels
- Screwless control terminals on detachable I/O board.

Performance features

- Latest IGBT technology
- Digital microprocessor control
- High-quality Vector Control system
- Flux Current Control (FCC) for improved dynamic response and optimized motor control
- Linear V/f characteristic
- Quadratic V/f characteristic
- Multipoint characteristic (programmable V/f characteristic)
- Torque control
- Flying restart
- Slip compensation
- Automatic restart following mains failure or fault
- User-definable function blocks for logic and arithmetic operations
- Kinetic buffering
- Positioning ramp down
- High-grade PID controller for simple internal process control (autotuning)
- Programmable acceleration/deceleration, 0 s to 650 s
- Ramp smoothing
- Fast Current Limit (FCL) for trip-free operation
- Fast, repeatable digital input response time
- Fine adjustment using two high-resolution 10-bit analog inputs
- Compound braking for controlled rapid braking
- Integrated brake chopper (for 0.12 kW to 75 kW inverters)
- Four skip frequencies
- Removable "Y" capacitor for use on IT systems (with non-grounded mains supplies, the "Y" capacitor must be removed and an output choke installed).

Protection features

- Overload capability
 - **CT mode**
0.12 kW to 75 kW:
Overload current 1.5 x rated output current (i.e. 150 % overload capability) for 60 s, cycle time 300 s, and 2 x rated output current (i.e. 200 % overload capability) for 3 s, cycle time 300 s
 - 90 kW to 200 kW:
Overload current 1.36 x rated output current (i.e. 136 % overload capability) for 57 s, cycle time 300 s, and 1.6 x rated output current (i.e. 160 % overload capability) for 3 s, cycle time 300 s
 - **VT mode**
5.5 kW to 90 kW:
Overload current 1.4 x rated output current (i.e. 140 % overload capability) for 3 s, and 1.1 x rated output current (i.e. 110 % overload capability) for 60 s, cycle time 300 s
 - 110 kW to 250 kW:
Overload current 1.5 x rated output current (i.e. 150 % overload capability) for 1 s, and 1.1 x rated output current (i.e. 110 % overload capability) for 59 s, cycle time 300 s
- Overvoltage/undervoltage protection
- Inverter overtemperature protection
- Special direct connection for PTC or KTY to protect the motor
- Earth fault protection
- Short-circuit protection
- βt motor thermal protection
- Locked motor protection
- Stall prevention
- Parameter interlock.

MICROMASTER 440

Circuit diagrams

General circuit diagram

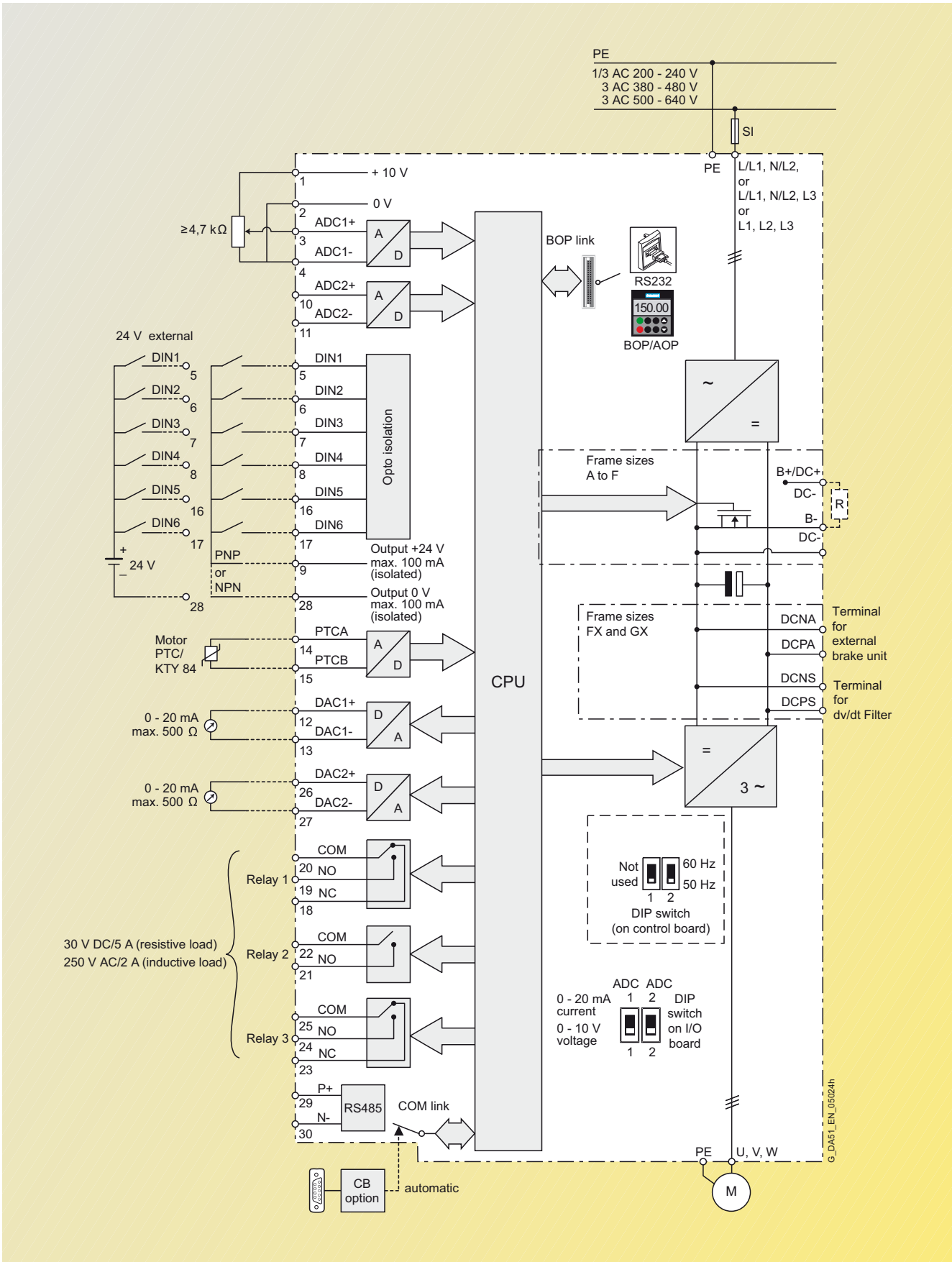

4

Terminal connection diagram

Example, frame size FX

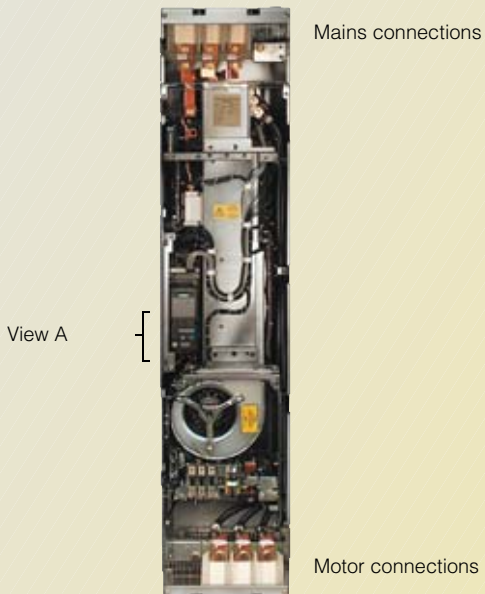

View A

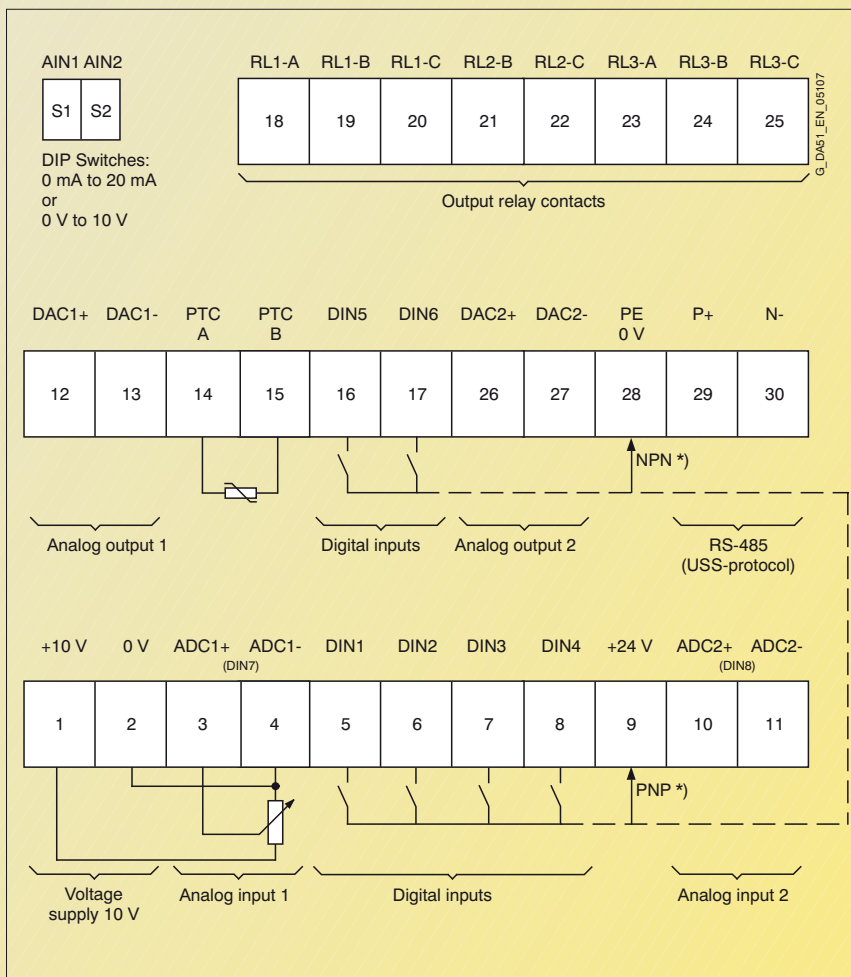

*) PNP or NPN possible

MICROMASTER 440

Technical data

MICROMASTER 440 inverter

Mains voltage and power ranges	1 AC 200 V to 240 V ± 10 % 3 AC 200 V to 240 V ± 10 % 3 AC 380 V to 480 V ± 10 % 3 AC 500 V to 600 V ± 10 %	CT (constant torque) 0.12 kW to 3 kW 0.12 kW to 45 kW 0.37 kW to 200 kW 0.75 kW to 75 kW	VT (variable torque) – 5.5 kW to 55 kW 7.5 kW to 250 kW 1.5 kW to 90 kW
Input frequency	47 Hz to 63 Hz		
Output frequency	0.12 kW to 75 kW 90 kW to 200 kW	0 Hz to 650 Hz (in <i>V/f</i> mode) 0 Hz to 200 Hz (in vector mode) (Due to legal restrictions a limitation to 550 Hz is under preparation) 0 Hz to 267 Hz (in <i>V/f</i> mode) 0 Hz to 200 Hz (in vector mode)	
Power factor	≥ 0.95		
Inverter efficiency	0.12 kW to 75 kW: 96 % to 97 %; 90 kW to 200 kW: 97 % to 98 % (Further information is available on the Internet at: http://support.automation.siemens.com/WW/view/en/22978972)		
Overload capability – CT mode	0.12 kW to 75 kW 90 kW to 200 kW	Overload current 1.5 x rated output current (i.e. 150 % overload capability) for 60 s, cycle time 300 s and 2 x rated output current (i.e. 200 % overload capability) for 3 s, cycle time 300 s Overload current 1.36 x rated output current (i.e. 136 % overload capability) for 57 s, cycle time 300 s and 1.6 x rated output current (i.e. 160 % overload capability) for 3 s, cycle time 300 s	
– VT mode	5.5 kW to 90 kW 110 kW to 250 kW	Overload current 1.4 x rated output current (i.e. 140 % overload capability) for 3 s, and 1.1 x rated output current (i.e. 110 % overload capability) for 60 s, cycle time 300 s Overload current 1.5 x rated output current (i.e. 150 % overload capability) for 1 s, and 1.1 x rated output current (i.e. 110 % overload capability) for 59 s, cycle time 300 s	
Inrush current	not higher than rated input current		
Control method	Vector control, torque control, linear <i>V/f</i> characteristic; quadratic <i>V/f</i> characteristic; Multipoint characteristic (programmable <i>V/f</i> characteristic); flux current control (FCC)		
Pulse frequency	0.12 kW to 75 kW 90 kW to 200 kW	4 kHz (standard); 16 kHz (standard with 230 V inverters 0.12 kW to 5.5 kW) 2 kHz to 16 kHz (in 2 kHz steps) 2 kHz (standard with VT mode); 4 kHz (standard with CT mode) 2 kHz to 4 kHz (in 2 kHz steps)	
Fixed frequencies	15, programmable		
Skip frequency ranges	4, programmable		
Setpoint resolution	0.01 Hz digital; 0.01 Hz serial; 10 bit analog		
Digital inputs	6 fully programmable isolated digital inputs; switchable PNP/NPN		
Analog inputs	2 programmable analog inputs • 0 V to 10 V, 0 mA to 20 mA and –10 V to +10 V (AIN1) • 0 V to 10 V and 0 mA to 20 mA (AIN2) • both can be used as 7th/8th digital input		
Relay outputs	3, programmable, 30 V DC/5 A (resistive load); 250 V AC/2A (inductive load)		
Analog outputs	2, programmable (0/4 mA to 20 mA)		
Serial interfaces	RS-485, optional RS-232		
Motor cable lengths	without output choke with output choke	0.12 – 75 kW: max. 50 m (shielded), max. 100 m (unshielded) 90 – 250 kW: max. 200 m (shielded), max. 300 m (unshielded) see variant dependent options	
Electromagnetic compatibility (see Selection and Ordering Data)	EMC filter, Class A or Class B to EN 55 011 available as an option Inverter with internal filter Class A available		
Braking	Resistance braking with DC braking, compound braking, integrated brake chopper (integrated brake chopper only with 0.12 kW to 75 kW inverters)		
Degree of protection	IP20		
Operating temperature (without derating)	0.12 kW to 75 kW 90 kW to 200 kW	CT: –10 °C to +50 °C (+14 °F to +122 °F) VT: –10 °C to +40 °C (+14 °F to +104 °F) 0 °C to +40 °C (+32 °F to +104 °F)	
Storage temperature	–40 °C to +70 °C (–40 °F to +158 °F)		
Relative humidity	95 % (non-condensing)		
Installation altitude	0.12 kW to 75 kW 90 kW to 200 kW	up to 1000 m above sea level without derating up to 2000 m above sea level without derating	
Standard SCCR (Short Circuit Current Rating) ¹⁾	FSA, FSB, FSC: 10 kA FSD, FSE, FSF, FSFX, FSGX: 65 kA		
Protection features for	Undervoltage, overvoltage, overload, earth faults, short-circuits, stall prevention, locked motor protection, motor over-temperature, inverter overtemperature, parameter change protection		
Compliance with standards	Ⓜ, cⓂ, CE, c-tick		
CE marking	Conformity with low-voltage directive 73/23/EEC		
Cooling-air volumetric flow required, dimensions and weights (without options)	Frame size (FS)	Cooling-air volumetric flow required (l/s)/(CFM)	H x W x D, max. (mm) Weight, approx. (kg)
	A	4.8/10.2	173 x 73 x 149 1.3
	B	24/51	202 x 149 x 172 3.4
	C	54.9/116.3	245 x 185 x 195 5.7
	D	2 x 54.9/2 x 116.3	520 x 275 x 245 17
	E	2 x 54.9/2 x 116.3	650 x 275 x 245 22
	F without filter	150/317.79	850 x 350 x 320 56
	F with filter	150/317.79	1150 x 350 x 320 75
	FX	225/478.13	1400 x 326 x 356 116
	GX	440/935	1533 x 326 x 545 174
1) For footnote, see page 4/7.			

CFM: Cubic Feet per Minute

Derating data

Pulse frequency

Output kW	Rated output current in A for a pulse frequency of						
	4 kHz	6 kHz	8 kHz	10 kHz	12 kHz	14 kHz	16 kHz
Mains voltage 1/3 AC 200 V							
0.12 to 5.5	Values correspond to the 4 kHz standard values. No derating, since 16 kHz standard.						
7.5	28.0	26.6	25.2	22.4	19.6	16.8	14.0
11	42.0	37.8	33.6	29.4	25.2	21.0	16.8
15	54.0	48.6	43.2	37.8	32.4	27.0	21.6
18.5	68.0	64.6	61.2	54.4	47.6	40.8	34.0
22	80.0	72.0	64.0	56.0	48.0	40.0	32.0
30	104.0	91.0	78.0	70.2	62.4	57.2	52.0
37	130.0	113.8	97.5	87.8	78.0	71.5	65.0
45	154.0	134.8	115.5	104.0	92.4	84.7	77.0
Mains operating voltage 3 AC 400 V							
0.37	1.3	1.3	1.3	1.3	1.3	1.2	1.0
0.55	1.7	1.7	1.7	1.6	1.5	1.4	1.2
0.75	2.2	2.2	2.2	2.0	1.8	1.5	1.3
1.1	3.1	2.9	2.8	2.5	2.2	1.9	1.6
1.5	4.1	3.7	3.3	2.9	2.5	2.1	1.6
2.2	5.9	5.6	5.3	4.7	4.1	3.5	3.0
3.0	7.7	6.9	6.2	5.4	4.6	3.9	3.1
4.0	10.2	9.2	8.2	7.1	6.1	5.1	4.1
5.5	13.2	11.9	10.6	9.2	7.9	6.6	5.3
7.5	19.0	18.1	17.1	15.2	13.3	11.4	9.5
11.0	26.0	23.4	20.8	18.2	15.6	13.0	10.4
15.0	32.0	30.4	28.8	25.6	22.4	19.2	16.0
18.5	38.0	34.2	30.4	26.6	22.8	19.0	15.2
22	45.0	40.5	36.0	31.5	27.0	22.5	18.0
30	62.0	58.9	55.8	49.6	43.4	37.2	31.0
37	75.0	67.5	60.0	52.5	45.0	37.5	30.0
45	90.0	76.5	63.0	51.8	40.5	33.8	27.0
55	110.0	93.5	77.0	63.3	49.5	41.3	33.0
75	145.0	112.4	79.8	68.9	58.0	50.8	43.5
90	178.0	–	–	–	–	–	–
110	205.0	–	–	–	–	–	–
132	250.0	–	–	–	–	–	–
160	302.0	–	–	–	–	–	–
200	370.0	–	–	–	–	–	–
Mains operating voltage 3 AC 500 V							
0.75	1.4	1.2	1.0	0.8	0.7	0.6	0.6
1.5	2.7	2.2	1.6	1.4	1.1	0.9	0.8
2.2	3.9	2.9	2.0	1.6	1.2	1.0	0.8
4.0	6.1	4.6	3.1	2.4	1.8	1.5	1.2
5.5	9.0	6.8	4.5	3.6	2.7	2.3	1.8
7.5	11.0	8.8	6.6	5.5	4.4	3.9	3.3
11.0	17.0	12.8	8.5	6.8	5.1	4.3	3.4
15.0	22.0	17.6	13.2	11.0	8.8	7.7	6.6
18.5	27.0	20.3	13.5	10.8	8.1	6.8	5.4
22	32.0	24.0	16.0	12.8	9.6	8.0	6.4
30	41.0	32.8	24.6	20.5	16.4	14.4	12.3
37	52.0	39.0	26.0	20.8	15.6	13.0	10.4
45	62.0	52.7	43.4	40.3	37.2	32.6	27.9
55	77.0	67.4	57.8	52.0	46.2	42.4	38.5
75	99.0	84.2	69.3	64.4	59.4	52.0	44.6

1) Applies to industrial control cabinet installations to NEC article 409/UL 508A.

MICROMASTER 440

Technical data

Derating data (continued)

Operating temperature

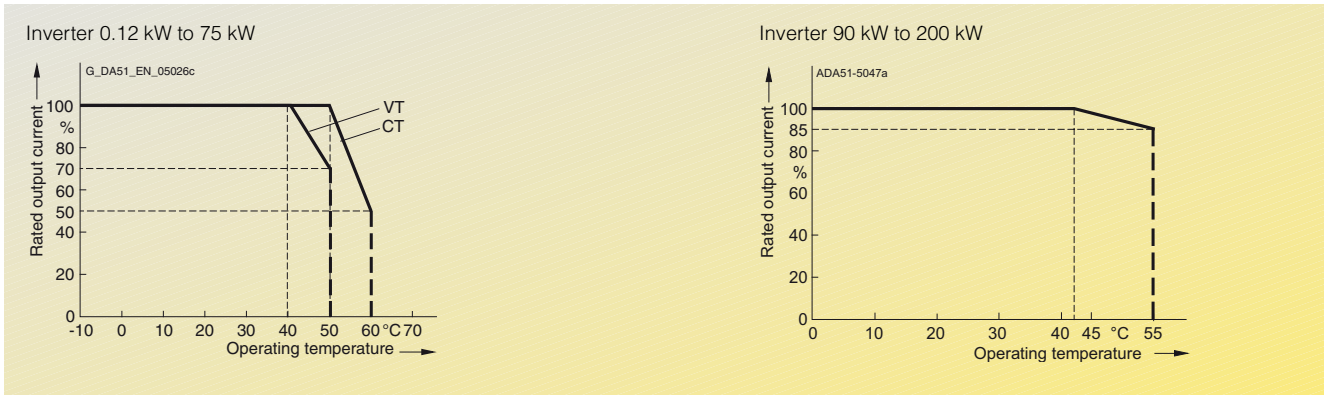

Installation altitude above sea level

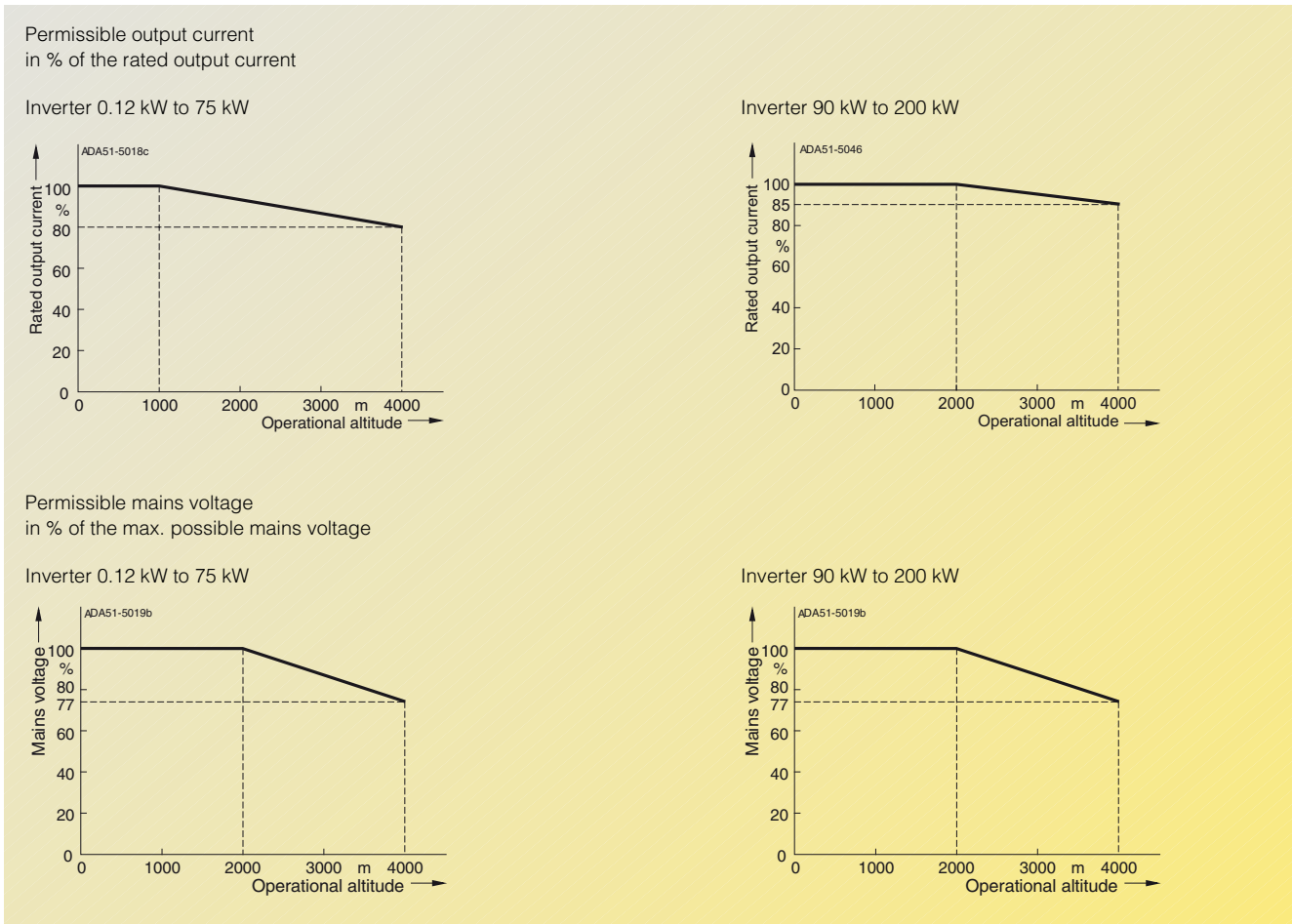

4

MICROMASTER 440 inverter without filter²⁾

CT (constant torque)				VT (variable torque)				MICROMASTER 440 without filter ²⁾		
Output		Rated input current ¹⁾	Rated output current	Output		Rated input current ¹⁾	Rated output current	Frame size (FS)	Weight, approx. kg	Order No.
kW	hp	A	A	kW	hp	A	A			
Mains voltage 1 AC 200 V to 240 V										
0.12	0.16	1.8	0.9	–	–	–	–	A	1.3	6SE6440-2UC11-2AA1
0.25	0.33	3.2	1.7	–	–	–	–	A	1.3	6SE6440-2UC12-5AA1
0.37	0.50	4.6	2.3	–	–	–	–	A	1.3	6SE6440-2UC13-7AA1
0.55	0.75	6.2	3.0	–	–	–	–	A	1.3	6SE6440-2UC15-5AA1
0.75	1.0	8.2	3.9	–	–	–	–	A	1.3	6SE6440-2UC17-5AA1
1.1	1.5	11.0	5.5	–	–	–	–	B	3.3	6SE6440-2UC21-1BA1
1.5	2	14.4	7.4	–	–	–	–	B	3.3	6SE6440-2UC21-5BA1
2.2	3	20.2	10.4	–	–	–	–	B	3.3	6SE6440-2UC22-2BA1
3.0	4	35.5	13.6	–	–	–	–	C	5.5	6SE6440-2UC23-0CA1
Mains operating voltage 3 AC 200 V to 240 V										
0.12	0.16	1.1	0.9	–	–	–	–	A	1.3	6SE6440-2UC11-2AA1
0.25	0.33	1.9	1.7	–	–	–	–	A	1.3	6SE6440-2UC12-5AA1
0.37	0.50	2.7	2.3	–	–	–	–	A	1.3	6SE6440-2UC13-7AA1
0.55	0.75	3.6	3.0	–	–	–	–	A	1.3	6SE6440-2UC15-5AA1
0.75	1.0	4.7	3.9	–	–	–	–	A	1.3	6SE6440-2UC17-5AA1
1.1	1.5	6.4	5.5	–	–	–	–	B	3.3	6SE6440-2UC21-1BA1
1.5	2.0	8.3	7.4	–	–	–	–	B	3.3	6SE6440-2UC21-5BA1
2.2	3.0	11.7	10.4	–	–	–	–	B	3.3	6SE6440-2UC22-2BA1
3.0	4.0	15.6	13.6	–	–	–	–	C	5.5	6SE6440-2UC23-0CA1
4.0	5.0	19.7	17.5	5.5	7.5	28.3	22	C	5.5	6SE6440-2UC24-0CA1
5.5	7.5	26.5	22	7.5	10	34.2	28	C	5.5	6SE6440-2UC25-5CA1
7.5	10	34.2	28	11.0	15	38.0	42	D	16	6SE6440-2UC27-5DA1
11.0	15	38.0	42	15.0	20	50.0	54	D	16	6SE6440-2UC31-1DA1
15.0	20	50.0	54	18.5	25	62.0	68	D	16	6SE6440-2UC31-5DA1
18.5	25	62.0	68	22	30	71.0	80	E	20	6SE6440-2UC31-8EA1
22	30	71.0	80	30	40	96.0	104	E	20	6SE6440-2UC32-2EA1
30	40	96.0	104	37	50	114.0	130	F	55	6SE6440-2UC33-0FA1
37	50	114.0	130	45	60	135.0	154	F	55	6SE6440-2UC33-7FA1
45	60	135.0	154	55	75	164.0	178	F	55	6SE6440-2UC34-5FA1
Mains operating voltage 3 AC 380 V to 480 V										
0.37	0.50	2.2	1.3	–	–	–	–	A	1.3	6SE6440-2UD13-7AA1
0.55	0.75	2.8	1.7	–	–	–	–	A	1.3	6SE6440-2UD15-5AA1
0.75	1.0	3.7	2.2	–	–	–	–	A	1.3	6SE6440-2UD17-5AA1
1.1	1.5	4.9	3.1	–	–	–	–	A	1.3	6SE6440-2UD21-1AA1
1.5	2.0	5.9	4.1	–	–	–	–	A	1.3	6SE6440-2UD21-5AA1
2.2	3.0	7.5	5.9	–	–	–	–	B	3.3	6SE6440-2UD22-2BA1
3.0	4.0	10.0	7.7	–	–	–	–	B	3.3	6SE6440-2UD23-0BA1
4.0	5.0	12.8	10.2	–	–	–	–	B	3.3	6SE6440-2UD24-0BA1
5.5	7.5	15.6	13.2	7.5	10	17.3	19	C	5.5	6SE6440-2UD25-5CA1
7.5	10	22.0	18.4	11.0	15	23.1	26	C	5.5	6SE6440-2UD27-5CA1
11.0	15	23.1	26	15.0	20	33.8	32	C	5.5	6SE6440-2UD31-1CA1
15.0	20	33.8	32	18.5	25	37.0	38	D	16	6SE6440-2UD31-5DA1
18.5	25	37.0	38	22	30	43.0	45	D	16	6SE6440-2UD31-8DA1
22	30	43.0	45	30	40	59.0	62	D	16	6SE6440-2UD32-2DA1
30	40	59.0	62	37	50	72.0	75	E	20	6SE6440-2UD33-0EA1
37	50	72.0	75	45	60	87.0	90	E	20	6SE6440-2UD33-7EA1
45	60	87.0	90	55	75	104.0	110	F	56	6SE6440-2UD34-5FA1
55	75	104.0	110	75	100	139.0	145	F	56	6SE6440-2UD35-5FA1
75	100	139.0	145	90	125	169.0	178	F	56	6SE6440-2UD37-5FA1

1) Supplementary conditions:
Input current at rated operating point, applicable at short-circuit voltage of the supply $U_{sc} = 2\%$ with reference to the inverter rated power and rated mains operating voltage of 240 V or 400 V without a line commutating choke.

2) Acc. to EMC EN 61800-3 generally suited to heavy industrial applications. For details please refer to Appendix on page A/4.

MICROMASTER 440

Selection and ordering data

MICROMASTER 440 inverter without filter³⁾ (continued)

CT (constant torque)			VT (variable torque)				MICROMASTER 440 without filter ³⁾			
Output		Rated input current	Rated output current		Output	Rated input current	Rated output current	Frame size	Weight, approx.	Order No.
kW	hp	A	A	kW	hp	A	A	(FS)	kg	
Mains operating voltage 3 AC 380 V to 480 V										
90	125	169.0 ¹⁾	178	110	150	200.0 ¹⁾	205	FX	116	6SE6440-2UD38-8FA1
110	150	200.0 ¹⁾	205	132	200	245.0 ¹⁾	250	FX	116	6SE6440-2UD41-1FA1
132	200	245.0 ¹⁾	250	160	250	297.0 ¹⁾	302	GX	174	6SE6440-2UD41-3GA1
160	250	297.0 ¹⁾	302	200	300	354.0 ¹⁾	370	GX	174	6SE6440-2UD41-6GA1
200	300	354.0 ¹⁾	370	250	350	442.0 ¹⁾	477	GX	174	6SE6440-2UD42-0GA1
Mains operating voltage 3 AC 500 V to 600 V										
0.75	1.0	2.0 ²⁾	1.4	1.5	2.0	3.2 ²⁾	2.7	C	5.5	6SE6440-2UE17-5CA1
1.5	2.0	3.7 ²⁾	2.7	2.2	3.0	4.4 ²⁾	3.9	C	5.5	6SE6440-2UE21-5CA1
2.2	3.0	5.3 ²⁾	3.9	4.0	5.0	6.9 ²⁾	6.1	C	5.5	6SE6440-2UE22-2CA1
4.0	5.0	8.1 ²⁾	6.1	5.5	7.5	9.4 ²⁾	9	C	5.5	6SE6440-2UE24-0CA1
5.5	7.5	11.1 ²⁾	9	7.5	10	12.6 ²⁾	11	C	5.5	6SE6440-2UE25-5CA1
7.5	10	14.4 ²⁾	11	11.0	15	18.1 ²⁾	17	C	5.5	6SE6440-2UE27-5CA1
11.0	15	21.5 ²⁾	17	15.0	20	24.9 ²⁾	22	C	5.5	6SE6440-2UE31-1CA1
15.0	20	24.9 ²⁾	22	18.5	25	30.0 ²⁾	27	D	16	6SE6440-2UE31-5DA1
18.5	25	30.0 ²⁾	27	22	30	35.0 ²⁾	32	D	16	6SE6440-2UE31-8DA1
22	30	35.0 ²⁾	32	30	40	48.0 ²⁾	41	D	16	6SE6440-2UE32-2DA1
30	40	48.0 ²⁾	41	37	50	58.0 ²⁾	52	E	20	6SE6440-2UE33-0EA1
37	50	58.0 ²⁾	52	45	60	69.0 ²⁾	62	E	20	6SE6440-2UE33-7EA1
45	60	69.0 ²⁾	62	55	75	83.0 ²⁾	77	F	56	6SE6440-2UE34-5FA1
55	75	83.0 ²⁾	77	75	100	113.0 ²⁾	99	F	56	6SE6440-2UE35-5FA1
75	100	113.0 ²⁾	99	90	120	138.0 ²⁾	125	F	56	6SE6440-2UE37-5FA1



See Appendix for note on ordering.

All MICROMASTER 440 inverters are supplied with a Status Display Panel (SDP). A BOP, AOP or other options have to be ordered separately (see Pages 4/16 to 4/22).

Motors for MICROMASTER 440

Catalog D 81.1 contains selection and ordering data for motors which are particularly suitable for operation with the MICROMASTER 440 inverters (see Appendix for overview).

This catalog is suitable for IEC motors. For motors according to US standards (NEMA) please refer to Catalog D 81.2 U.S./Canada (see Appendix for overview) and to: <http://www.sea.siemens.com/motors>

1) Supplementary conditions:
Input current at rated operating point, applicable at short-circuit voltage of the supply $U_{sc} \geq 2.33\%$ with reference to the inverter rated power and rated mains operating voltage of 400 V.

2) Supplementary conditions:
Input current at rated operating point, applicable at short-circuit voltage of the supply $U_{sc} = 2\%$ with reference to the inverter rated power and rated mains operating voltage of 500 V without a line commutating choke.

3) Acc. to EMC EN 61800-3 generally suited to heavy industrial applications. For details please refer to Appendix on page A/4.

MICROMASTER 440

Dimension drawings

MICROMASTER 440 inverter

Frame size	1/3 AC 200 V to 240 V	3 AC 380 V to 480 V	3 AC 500 V to 600 V
A	0.12 kW to 0.75 kW	0.37 kW to 1.5 kW	–
B	1.1 kW to 2.2 kW	2.2 kW to 4 kW	–
C	3 kW to 5.5 kW	5.5 kW to 11 kW	0.75 kW to 11 kW

The specified outputs are valid for CT mode.

Note:
The inverters must not be mounted horizontally. But the inverters can be mounted without lateral spacing.

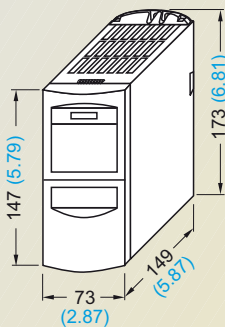

Inverter frame size **A**

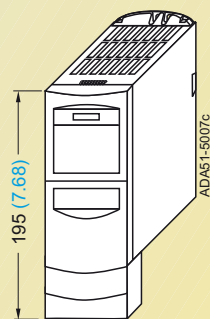
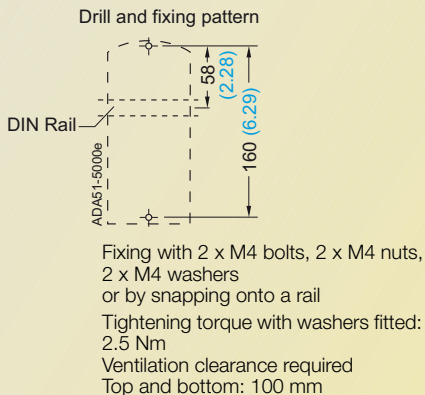

Inverter frame size **A** with **gland plate**

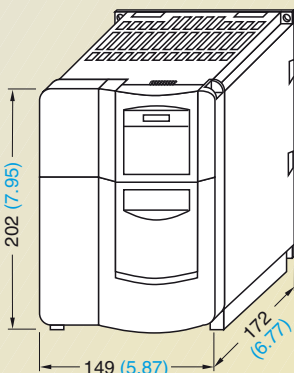

Inverter frame size **B**

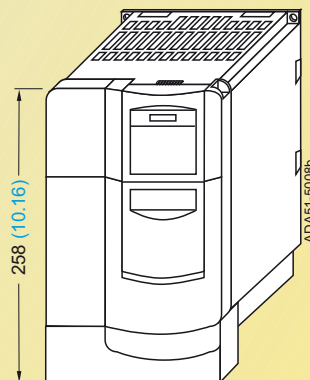
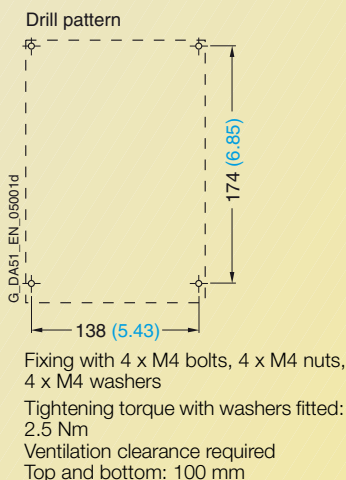

Inverter frame size **B** with **gland plate**

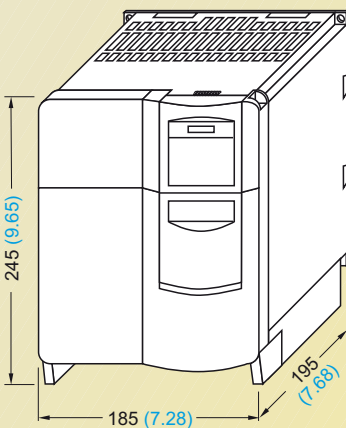

Inverter frame size **C**

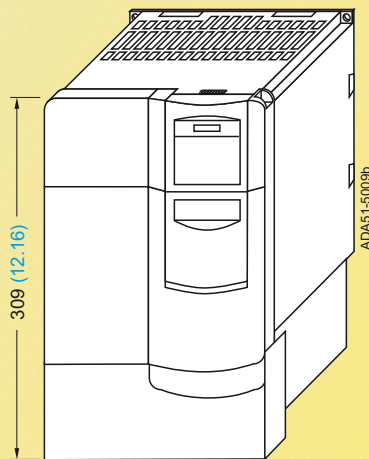
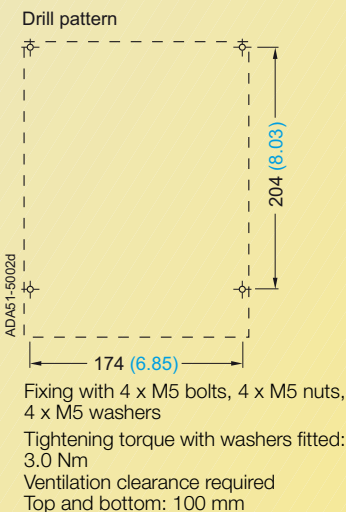

Inverter frame size **C** with **gland plate**

With the communications module, the mounting depth increases by 23 mm (0.91 inches). If a pulse encoder evaluation module is mounted in addition, the installation depth increases by another 23 mm (0.91 inches).

All dimensions in mm (values in brackets are in inches)

4

MICROMASTER 440 inverter (continued)

Frame size	3 AC 200 V to 240 V	3 AC 380 V to 480 V	3 AC 500 V to 600 V
D	7.5 kW to 15 kW	15 kW to 22 kW	15 kW to 22 kW
E	18.5 kW to 22 kW	30 kW to 37 kW	30 kW to 37 kW
F	30 kW to 45 kW	45 kW to 75 kW	45 kW to 75 kW

Note:
The inverters must not be mounted horizontally. But the inverters can be mounted without lateral spacing.

The specified outputs are valid for CT mode.

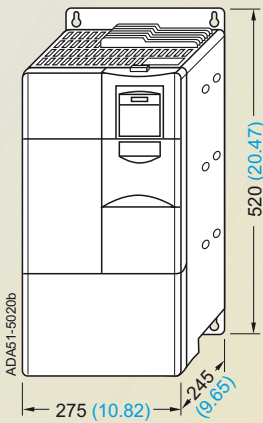

Inverter frame size D



Fixing with
4 x M8 bolts, 4 x M8 nuts,
4 x M8 washers

Tightening torque with washers
fitted: 13 Nm
Ventilation clearance required
Top and bottom: 300 mm

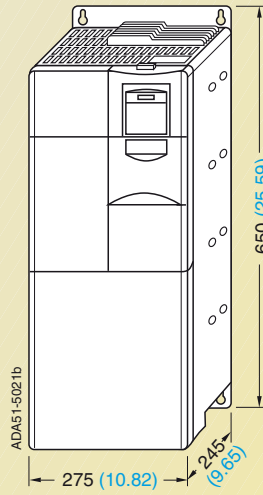

Inverter frame size E

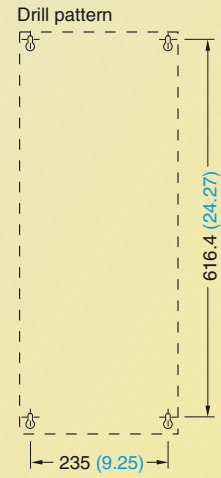

Fixing with
4 x M8 bolts, 4 x M8 nuts,
4 x M8 washers

Tightening torque with washers
fitted: 13 Nm
Ventilation clearance required
Top and bottom: 300 mm

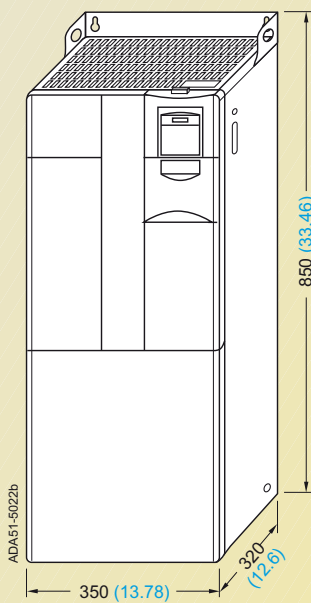

**Inverter frame size F
without filter**



Fixing with
4 x M8 bolts, 4 x M8 nuts,
4 x M8 washers

Tightening torque with washers
fitted: 13 Nm
Ventilation clearance required
Top and bottom: 350 mm

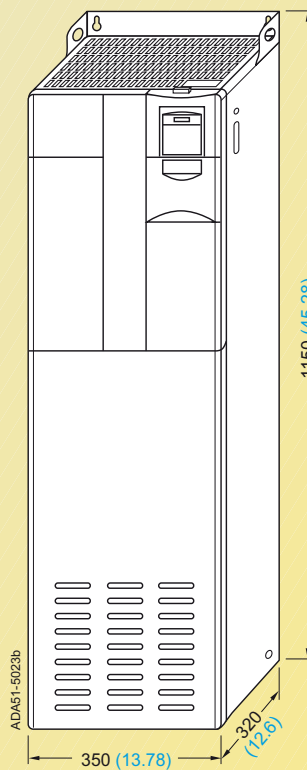

**Inverter frame size F
with filter**

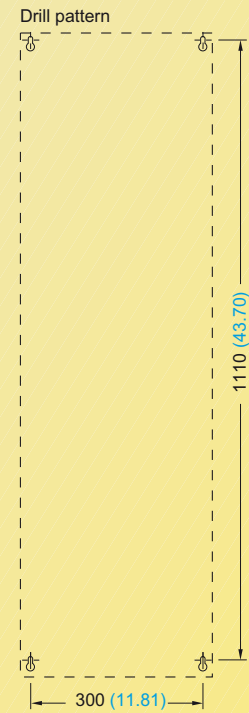

Fixing with
4 x M8 bolts, 4 x M8 nuts,
4 x M8 washers

Tightening torque with washers
fitted: 13 Nm
Ventilation clearance required
Top and bottom: 350 mm

All dimensions in mm (values in brackets are in inches)