

SIEMENS

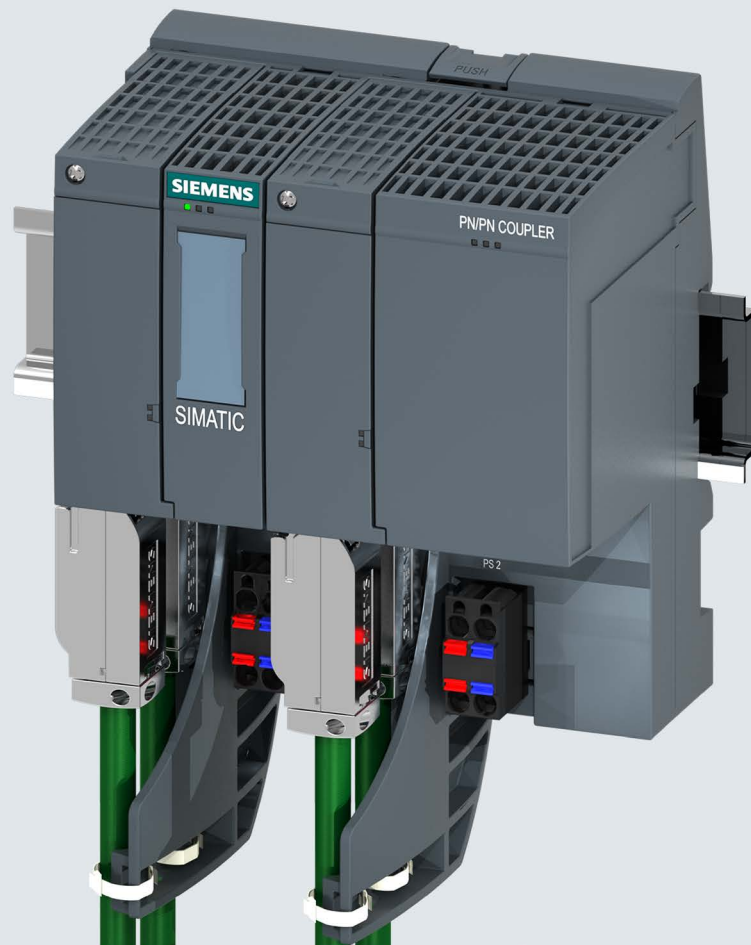

Installation and operating manual

SIMATIC

Bus links

PN/PN Coupler

Edition

12/2017

support.industry.siemens.com

SIEMENS

SIMATIC

Bus links PN/PN coupler



Hardware Installation and Operating Manual

Preface	
Documentation guide	1
Product overview	2
Assembling	3
Connecting	4
Configuring, parameter assignment and commissioning	5
Functions	6
Interrupts, error messages and diagnostics and system alarms	7
Operation and maintenance	8
Technical specifications	9
Dimension drawing	A
Article numbers and accessories	B
Response times	C
Compatibility	D

Legal information

Warning notice system

This manual contains notices you have to observe in order to ensure your personal safety, as well as to prevent damage to property. The notices referring to your personal safety are highlighted in the manual by a safety alert symbol, notices referring only to property damage have no safety alert symbol. These notices shown below are graded according to the degree of danger.

 DANGER
indicates that death or severe personal injury will result if proper precautions are not taken.
 WARNING
indicates that death or severe personal injury may result if proper precautions are not taken.
 CAUTION
indicates that minor personal injury can result if proper precautions are not taken.
NOTICE
indicates that property damage can result if proper precautions are not taken.

If more than one degree of danger is present, the warning notice representing the highest degree of danger will be used. A notice warning of injury to persons with a safety alert symbol may also include a warning relating to property damage.

Qualified Personnel

The product/system described in this documentation may be operated only by **personnel qualified** for the specific task in accordance with the relevant documentation, in particular its warning notices and safety instructions. Qualified personnel are those who, based on their training and experience, are capable of identifying risks and avoiding potential hazards when working with these products/systems.

Proper use of Siemens products

Note the following:

 WARNING
Siemens products may only be used for the applications described in the catalog and in the relevant technical documentation. If products and components from other manufacturers are used, these must be recommended or approved by Siemens. Proper transport, storage, installation, assembly, commissioning, operation and maintenance are required to ensure that the products operate safely and without any problems. The permissible ambient conditions must be complied with. The information in the relevant documentation must be observed.

Trademarks

All names identified by ® are registered trademarks of Siemens AG. The remaining trademarks in this publication may be trademarks whose use by third parties for their own purposes could violate the rights of the owner.

Disclaimer of Liability

We have reviewed the contents of this publication to ensure consistency with the hardware and software described. Since variance cannot be precluded entirely, we cannot guarantee full consistency. However, the information in this publication is reviewed regularly and any necessary corrections are included in subsequent editions.

Preface

Preface

Purpose of this manual

This manual provides all the necessary information for configuring, installing, connecting and commissioning the PN/PN Coupler.

Required basic knowledge

The following knowledge is required in order to understand the manual:

- General knowledge of automation technology
- Knowledge of the use of computers or PC -like tools (e.g. programming devices) under the Windows operating system.
- Knowledge of working with STEP 7 You can find information on this topic in the STEP 7 online help.

Scope of the manual

This manual is valid for PN/PN Coupler V4.0 with article number 6ES7158-3AD10-0XA0.

This manual contains a description of the components that were valid at the time the manual was published. We reserve the right to include up-to-date Product Information with new components and new versions of components.

Recycling and disposal

The PN/PN Coupler is low in contaminants and can therefore be recycled. For environmentally sustainable recycling and disposal of your old device, please contact a company certified for the disposal of electronic waste.

Security information

Siemens provides products and solutions with industrial security functions that support the secure operation of plants, systems, machines and networks.

In order to protect plants, systems, machines and networks against cyber threats, it is necessary to implement – and continuously maintain – a holistic, state-of-the-art industrial security concept. Siemens' products and solutions constitute one element of such a concept.

Customers are responsible for preventing unauthorized access to their plants, systems, machines and networks. Such systems, machines and components should only be connected to an enterprise network or the internet if and to the extent such a connection is necessary and only when appropriate security measures (e.g. firewalls and/or network segmentation) are in place.

For additional information on industrial security measures that may be implemented, please visit (<http://www.siemens.com/industrialsecurity>).

Siemens' products and solutions undergo continuous development to make them more secure. Siemens strongly recommends that product updates are applied as soon as they are available and that the latest product versions are used. Use of product versions that are no longer supported, and failure to apply the latest updates may increase customers' exposure to cyber threats.

To stay informed about product updates, subscribe to the Siemens Industrial Security RSS Feed under (<http://www.siemens.com/industrialsecurity>).

Siemens Industry Online Support

You can find current information on the following topics quickly and easily here:

- **Product support**

All the information and extensive know-how on your product, technical specifications, FAQs, certificates, downloads, and manuals.

- **Application examples**

Tools and examples to solve your automation tasks – as well as function blocks, performance information and videos.

- **Services**

Information about Industry Services, Field Services, Technical Support, spare parts and training offers.

- **Forums**

For answers and solutions concerning automation technology.

- **mySupport**

Your personal working area in Industry Online Support for messages, support queries, and configurable documents.

This information is provided by the Siemens Industry Online Support in the Internet (<http://www.siemens.com/automation/service&support>).

Industry Mall

The Industry Mall is the catalog and order system of Siemens AG for automation and drive solutions on the basis of Totally Integrated Automation (TIA) and Totally Integrated Power (TIP).

You can find catalogs for all automation and drive products on the Internet (<https://mall.industry.siemens.com>).

Table of contents

	Preface	3
1	Documentation guide	9
2	Product overview	12
2.1	New functions compared to PN/PN Coupler up to V3.0	12
2.2	Area of application and function.....	15
2.3	Properties	18
2.4	Operator controls and display elements	21
3	Assembling	23
3.1	Assembly rules	23
3.2	Assembling the PN/PN coupler.....	24
3.3	Disassembling the PN/PN coupler	25
3.4	Applying labeling strips	25
3.5	Applying reference identification labels	26
4	Connecting	27
4.1	Electrical isolation and grounding	27
4.1.1	Introduction	27
4.1.2	General operating rules and regulations.....	27
4.2	Connections	29
4.3	Connecting the power supply.....	30
4.4	Connecting the BusAdapter	34
4.4.1	Connecting PROFINET IO to the PN/PN Coupler using BusAdapter BA 2xRJ45	34
4.4.2	Connecting PROFINET IO to the PN/PN Coupler using BusAdapter BA 2xFC	35
4.4.3	Connecting PROFINET IO to the PN/PN Coupler using BusAdapter BA 2xSCRJ	38
4.4.4	Connecting PROFINET IO to the PN/PN Coupler using BusAdapter BA SCRJ/FC	40
4.4.5	Connecting PROFINET IO to the PN/PN Coupler using BusAdapter BA SCRJ/RJ45.....	41
4.4.6	Connecting PROFINET IO to the PN/PN Coupler using BusAdapter BA 2xLC	42
4.4.7	Connecting PROFINET IO to the PN/PN Coupler using BusAdapter BA LC/RJ45	45
4.4.8	Connecting PROFINET IO to the PN/PN Coupler using BusAdapter BA LC/FC	46
4.5	Connecting PROFINET IO	47
4.6	Strain relief.....	52
4.6.1	Product overview.....	52
4.6.2	Installing	53
4.7	Block diagram	54
5	Configuring, parameter assignment and commissioning	55
5.1	Configuring and commissioning of the PN/PN coupler (overview)	55

5.2	Requirements.....	55
5.3	Assignment of the modules	56
5.4	Configuring the PN/PN Coupler with STEP 7 TIA Portal.....	58
5.4.1	Configuring the PN/PN Coupler with STEP 7 TIA Portal.....	58
5.4.2	Example: Configuring with STEP 7 TIA Portal	59
5.4.3	Generating a GSD file with STEP 7 TIA Portal.....	60
5.5	Configuring the PN/PN Coupler with a different configuration tool.....	61
5.6	Parameters	62
5.7	Commissioning the PN/PN coupler	64
5.8	Identification data.....	65
6	Functions.....	67
6.1	Data record transfer from one IO controller to another IO controller.....	67
6.1.1	Principle of operation	67
6.1.2	Structure and meaning of status information for the data record transfer	71
6.2	PROFINET IO functions.....	73
6.2.1	Device replacement	73
6.2.2	Isochronous real-time communication	74
6.2.3	Prioritized startup	74
6.2.4	Media redundancy (MRP).....	75
6.2.5	Shared Device	76
6.2.6	Media Redundancy with Planned Duplication (MRPD)	78
6.3	Shared Input/Shared Output as communication functions	79
6.3.1	Interface local distribution of IO data	79
6.3.2	Coupling across the network and interface local distribution of IO data.....	81
6.3.3	Coupling across the network and distribution and interface local distribution of IO data	83
7	Interrupts, error messages and diagnostics and system alarms.....	85
7.1	Diagnostics via LED displays.....	85
7.2	Diagnostics by user program	89
7.2.1	Extended channel diagnostics	89
7.2.2	Interrupts.....	90
7.2.3	Diagnostics readout	91
7.2.4	Data validity display	92
7.2.5	Diagnosis in Shared Device.....	92
7.2.6	STOP of the IO controller and recovery of the IO device	93
8	Operation and maintenance	94
8.1	Updating firmware via PROFINET IO	94
8.2	Replacing defective PN/PN coupler.....	95
8.3	Reset to factory settings	96

9	Technical specifications	98
9.1	General technical specifications	98
9.1.1	Introduction	98
9.1.2	Standards and approvals	98
9.1.3	Electromagnetic compatibility	103
9.1.4	Transport and storage conditions	105
9.1.5	Mechanical and climatic ambient conditions for operation	106
9.1.6	Specifications for insulation tests, safety class and degree of protection.....	109
9.1.7	Rated voltage	109
9.2	Technical specifications of PN/PN Coupler (6ES7158-3AD10-0XA0).....	110
A	Dimension drawing	112
B	Article numbers and accessories.....	113
C	Response times	115
D	Compatibility	116
	Glossary	117
	Index	125

Documentation guide

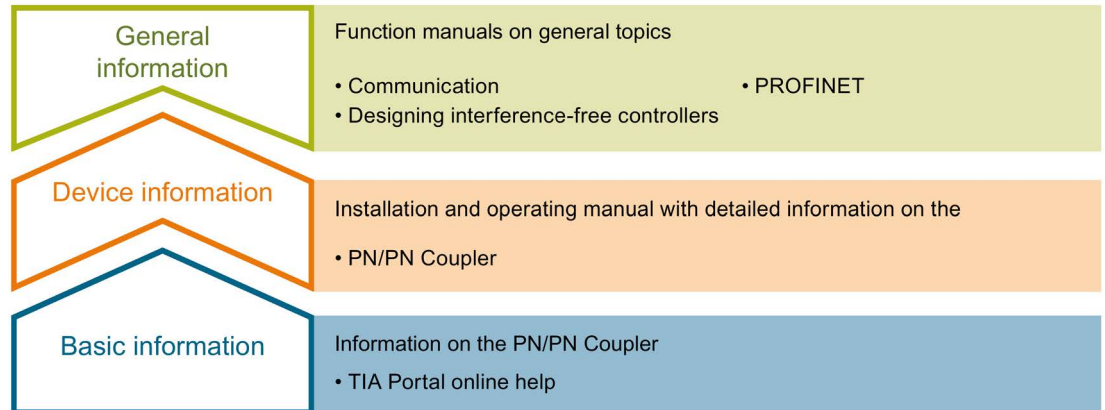

Device information

The Bus Links PN/PN Coupler Hardware Installation and Operating Manual contains information, for example, on properties, assembling, connecting, configuring and parameter assignment, alarms and diagnostics and technical specifications of the PN/PN Coupler.

General information

The function manuals contain detailed descriptions on general topics such as PROFINET and communication.

You can download the documentation free of charge from the Internet (<https://support.industry.siemens.com/cs/ww/en/view/109742709>).

"mySupport"

With "mySupport", your personal work area, you make the most of your Industry Online Support.

In "mySupport" you can store filters, favorites and tags, request CAx data and compile your own personal library in the Documentation area. Furthermore, your data is automatically filled in for support requests and you can get a quick overview of your current requests.

You need to register once to use the full functionality of "mySupport".

You can find "mySupport" on the Internet (<https://support.industry.siemens.com/My/ww/en>).

"mySupport" - Documentation

In the Documentation area of "mySupport", you have the possibility to combine complete manuals or parts of them to make your own manual.

You can export the manual in PDF format or in an editable format.

You can find "mySupport" - Documentation on the Internet (<http://support.industry.siemens.com/My/ww/en/documentation>).

"mySupport" - CAx Data

In the CAx Data area of "mySupport", you can access the latest product data for your CAx or CAe system.

You configure your own download package with a few clicks.

In doing so you can select:

- Product images, 2D dimension drawings, 3D models, internal circuit diagrams, EPLAN macro files
- Manuals, characteristics, operating instructions, certificates
- Product master data

You can find "mySupport" - CAx Data on the Internet (<http://support.industry.siemens.com/my/ww/en/CAxOnline>).

Application examples

The application examples support you with various tools and examples for solving your automation tasks. Here, solutions involving the interaction of multiple components in the system are shown, thus departing from the focus on individual products.

You can find the application examples on the Internet (<https://support.industry.siemens.com/sc/ww/en/sc/2054>).

SIMATIC Automation Tool

You can use the SIMATIC Automation Tool to perform commissioning and maintenance activities simultaneously on various SIMATIC S7 stations as a bulk operation independent of the TIA Portal.

The SIMATIC Automation Tool provides a multitude of functions:

- Scanning of a PROFINET/Ethernet system network and identification of all connected CPUs
- Address assignment (IP, subnet, gateway) and station name (PROFINET device) to a CPU
- Transfer of the date and the programming device/PC time converted to UTC time to the module
- Program download to CPU
- RUN/STOP mode switchover
- CPU localization by means of LED flashing
- Reading out of CPU error information
- Reading of the CPU diagnostic buffer
- Reset to factory settings
- Firmware update of the CPU and connected modules

You can find the SIMATIC Automation Tool on the Internet (<https://support.industry.siemens.com/cs/ww/en/view/98161300>).

PRONETA

With SIEMENS PRONETA (PROFINET network analysis), you analyze the plant network during commissioning. PRONETA features two core functions:

- The topology overview independently scans PROFINET and all connected components.
- PRONETA also scans: configuration of the station name, IP subnet mask and identification and maintenance data (I&M1..3)

You can find SIEMENS PRONETA on the Internet

(<https://support.industry.siemens.com/cs/ww/en/view/67460624>).

Product overview

2.1 New functions compared to PN/PN Coupler up to V3.0

Data coupling as of firmware version V4.0 over two additional module operating modes

The new PN/PN Coupler, firmware version V4.0, offers stronger decoupled data transmission between the two network sides. This provides the following advantages:

- Flexible adaptation of the diagnostic options to the different applications
- Free configuration of the response to communication interruptions on the other network side depending on the requirements
- Easier coupling with third-party systems

In the configuration, this module operating mode is referred to as "IO Modules". It is best to use this module operating mode for new projects.

If necessary, you can also configure the previous operating mode (up to FW version V3.x, 6ES7158-3AD00-0XA0 or 6ES7158-3AD01-0XA0) with closer coupling of the two network sides, for example, to extend existing projects, for spare parts.

In the configuration this module operating mode is referred to as "IO Modules (ext. comp. V3.x)".

Additional new functions of the PN/PN Coupler in firmware version V4.0

In addition to data coupling, you can find the additional new functions of the PN/PN Coupler in the table below.

Table 2- 1 Additional new functions of the PN/PN Coupler with FW version 4.0 compared with firmware version \leq V3.0

New functions	Applications	Customer benefits	Where can I find the information?
STEP 7 TIA Portal	You can configure and program everything with STEP 7 TIA Portal: from a CPU to distributed I/O and even the PN/PN Coupler.		Section Configuring the PN/PN Coupler with STEP 7 TIA Portal (Page 58)
SIMATIC BusAdapter	You have set up your PROFINET IO network with copper or fiber-optic cable according to your application. You integrate the PN/PN Coupler with the corresponding BusAdapter in the network. You can use different BusAdapters on each side of the network.	You can choose any transmission hardware and connection technology, i.e.: <ul style="list-style-type: none"> • Transmission hardware: copper, POF, PCF, glass fiber • Combination variant for use as integrated media converter (Cu\leftrightarrowFO) • Different cable lengths: <ul style="list-style-type: none"> – 50 m (POF) – 100 m (Cu, PCF) – 3000 m (glass fiber) 	Section Connecting the BusAdapter (Page 34)
Shared Device with 4 IO controllers	You have systems in which you assign your IO devices to up to four IO controllers.	With one PN/PN Coupler, you allocate your data to up to 4 IO controllers on each network side of the PN/PN Coupler.	Section Shared Device (Page 76)
Module-internal Shared Input/Shared Output (MSI/MSO)	With module-internal Shared Input, you allocate a copy your input data simultaneously to up to 3 IO controllers. With module-internal Shared Output you allocate a copy your output data simultaneously to up to 3 IO controllers. It does not matter whether you copy the three copies of the input data (MSI data) or output data (MSO data) to the same side of the network (Module-internal MSI/MSO) or the other network side.	You simultaneously distribute data from a CPU on one side of the network: <ul style="list-style-type: none"> • To multiple CPUs of the own side • To multiple CPUs of the other side 	Section Shared Device (Page 76)
Expanded I/O quantities	Across all IO controllers you can couple a total of 1440 bytes input data and 1440 bytes output data consisting of user data and user data qualifiers.	You can transfer large amounts of data.	Section Principle of operation (Page 67)

2.1 New functions compared to PN/PN Coupler up to V3.0

New functions	Applications	Customer benefits	Where can I find the information?
Extended diagnostics	Extended monitoring of the coupling partners. This takes place over a separate byte for data validity "DS".	Fast localization of configuration errors of the PN/PN Coupler and errors on the other network side.	Section Configuring the PN/PN Coupler with a different configuration tool (Page 61)
PROFINET performance upgrade	You can develop applications with high demands on speed and clock cycles.	Better utilization of the bandwidth results in short reaction times.	PROFINET with STEP 7 V14 (http://support.automation.siemens.com/WW/view/en/49948856) function manual
PROFINET send clock up to 125 µs	You implement applications with high demands on send clocks.	You implement high-speed applications as of 125 µs.	PROFINET with STEP 7 V14 (http://support.automation.siemens.com/WW/view/en/49948856) function manual
Shortened copying times	With short copying times you achieve fast update times and better data transmission performance.		-
Network loading class 3	You have the option to use the PN/PN Coupler in systems with high network loading.	The PN/PN Coupler is immune to interference caused by a high network load from Ethernet communication.	-
MRPD: Media Redundancy for Planned Duplication for IRT	By sending the cyclic IO data in both directions in the ring, a ring interruption does not disrupt the communication with the IO devices or result in device failure even in the case of short update times.	You achieve higher failure safety than with MRP (Media Redundancy Protocol).	PROFINET with STEP 7 V14 (http://support.automation.siemens.com/WW/view/en/49948856) function manual
Failure of the removable medium	The BusAdapter takes over the previous function of the device replacement with removable medium. Topological configuration is not required.	You save on storage media.	Section Device replacement (Page 73)
Extended channel diagnostics	The channel diagnostics provides information about channel faults of the PN/PN Couplers. Channel faults are mapped as extended channel diagnostics in IO diagnostic data records.	You localize a fault faster and save time and money.	Section Extended channel diagnostics (Page 89)
Pushbutton for restoring the factory settings on the back of the device	You have an easy and fast way to reset all data to factory settings, firmware updates remain in effect: <ul style="list-style-type: none"> On the PN/PN Coupler side that is supplied with 24 V DC If both sides are supplied with 24 V DC, both are deleted If a BusAdapter is plugged in, its data is deleted 		Section Reset to factory settings (Page 96)
GSD export for a partner side (X1 or X2)	On one side of the PN/PN Coupler you have a partner that can only be configured using a GSD. In this case, you can generate a GSD for the partner side.		Section Generating a GSD file with STEP 7 TIA Portal (Page 60)

2.2 Area of application and function

Area of application and customer benefits

You use the PN/PN Coupler in order to:

- Connect two Ethernet subnets together and exchange data
- Couple up to 4 IO controllers per network side

You use:

- User data via input or output address areas, or
- Data records

The maximum size of the transferable input and output data is 1440 bytes, respectively. The input and output data can be divided as desired. For example, you configure 1200 bytes of input data and 1340 bytes of output data.

The PN/PN Coupler is a device with two PROFINET interfaces that are each connected to a subnet.

During configuring, STEP 7 creates two IO devices with their subnets from a PN/PN Coupler. The other part of the PN/PN Coupler in each case is known as the coupling partner.

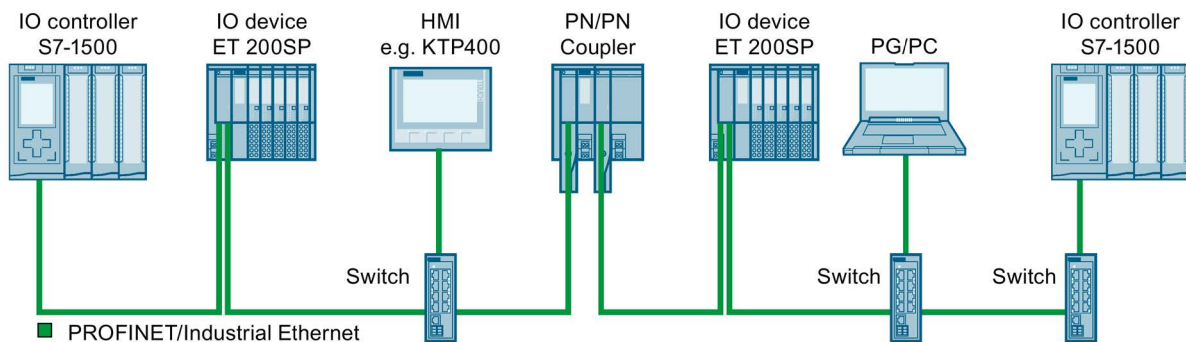

Figure 2-1 Coupling of two PROFINET IO subnets with one PN/PN Coupler

2.2 Area of application and function

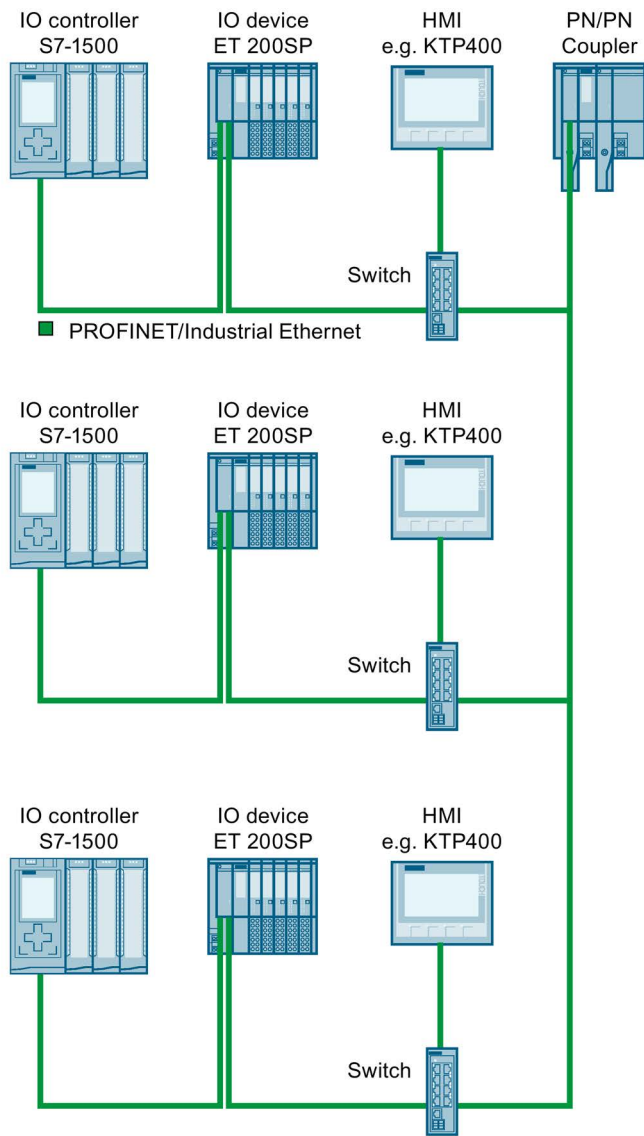

Figure 2-2 Communication between IO controllers on the same network side

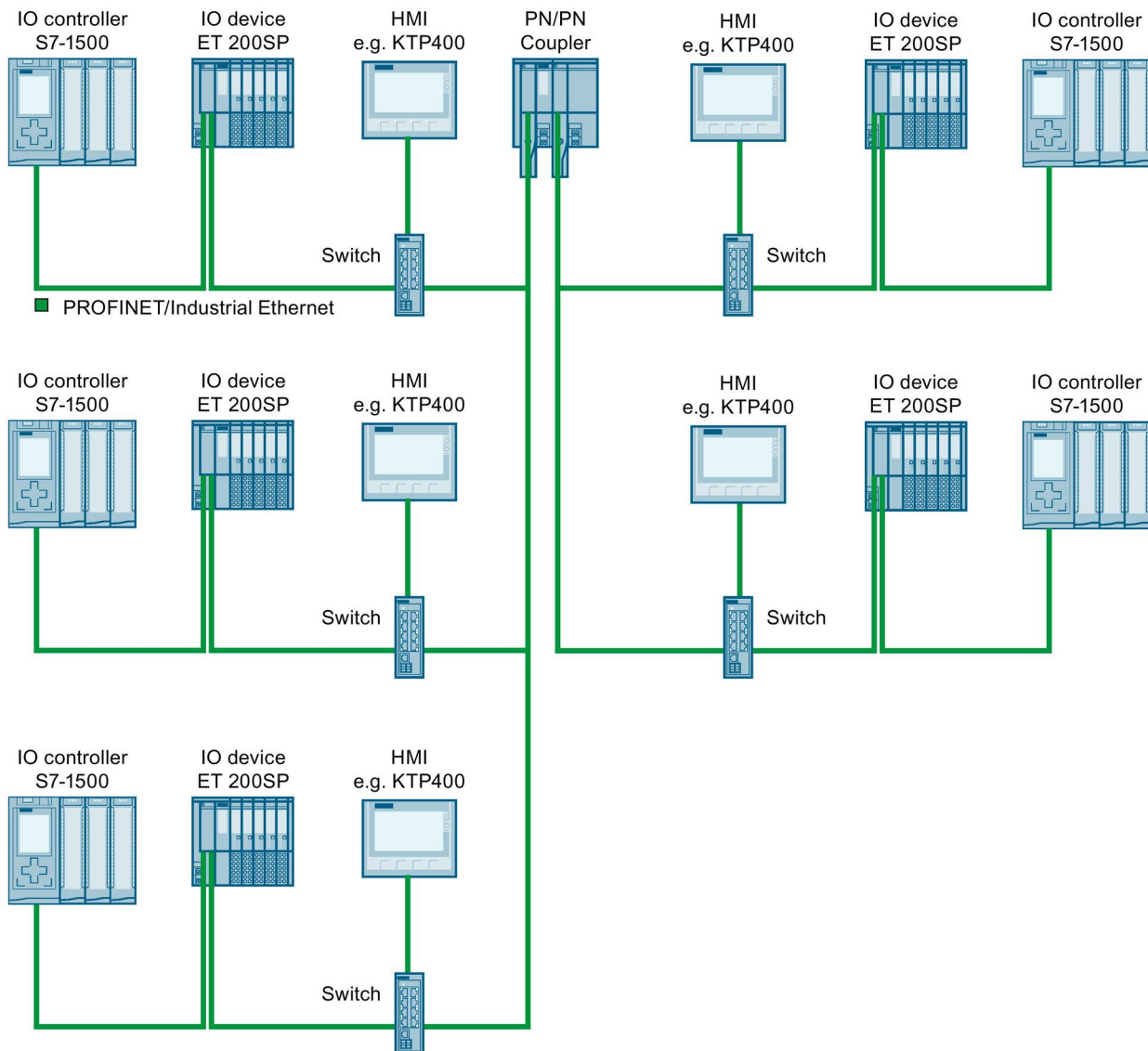

Figure 2-3 Communication between IO controllers on different network sides

Principle of operation

- Data exchange with I/O modules:

Through the configured inputs of a slot, the local CPU reads the values that the CPU of the other subnet writes over the configured outputs of the coupling partner.

Through the configured outputs of a slot, the local CPU writes values that the CPU of the other subnet receives over the configured inputs of the coupling partner.

- Data record transfer:

The module types Publisher and Storage are available. Each type consists of Read and Right combinations (see Assignment of the modules (Page 56)). For the data record transfer, the module types address the data record job using module addresses in each case (see Principle of operation (Page 67)).

2.3 Properties

Article number

6ES7158-3AD10-0XA0

View

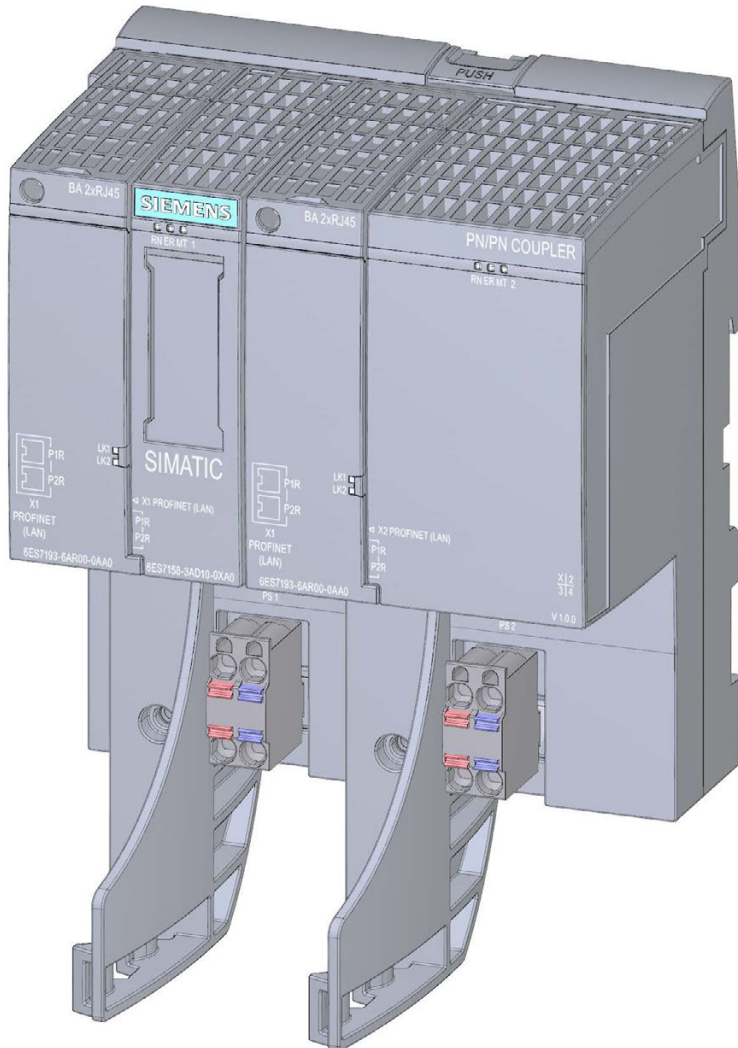

Figure 2-4 View of the PN/PN Coupler with mounted strain relief (accessory)

Properties

The PN/PN Coupler has the following properties:

- Data record transfer from an IO controller of one side to an IO controller of the other side.
- Data exchange of maximum 1440 bytes input data and 1440 bytes output data, divided as desired among up to 4 IO controllers.
- Maximum of 16 input areas/output areas for exchange of data with the following virtual modules:
 - IN
 - OUT
 - IN/OUT
 - RD WRITE STO
 - RD READ STO
 - RD WRITE PUB
 - RD READ PUB
 - MSI
 - MSO
 - MSI/MSO
 - MSO LOCAL
- Electrical isolation between the two PROFINET IO subnets
- Redundant power supply
- Supply voltage 1L+ 24 V DC (SELV/PELV)
- SIMATIC BusAdapter
- Diagnostics interrupts
- Extended channel diagnostics
- Status information of the input user data when using the "IO Modules" module operating mode
- Update interrupts
- Reset to factory settings via RESET button

Properties via PROFINET IO

- Integrated switch on both sides with 2 ports
- Supported Ethernet services: ping, arp, SNMP, LLDP
- Port diagnostics
- Port disabling
- Device replacement without removable medium/programming device
- Isochronous real-time communication
- Firmware update via PROFINET IO
- Prioritized startup
- Media redundancy MRP or MRPD
- Shared Device with 4 IO controllers, on both sides in each case
- Module-internal Shared Input/Shared Output (MSI/MSO)

Accessories

You order the following accessories separately:

- SIMATIC BusAdapter
- Labeling strips
- Reference identification label

You can find a detailed list of available accessories in the appendix Article numbers and accessories (Page 113).

2.4 Operator controls and display elements

Display elements and interfaces

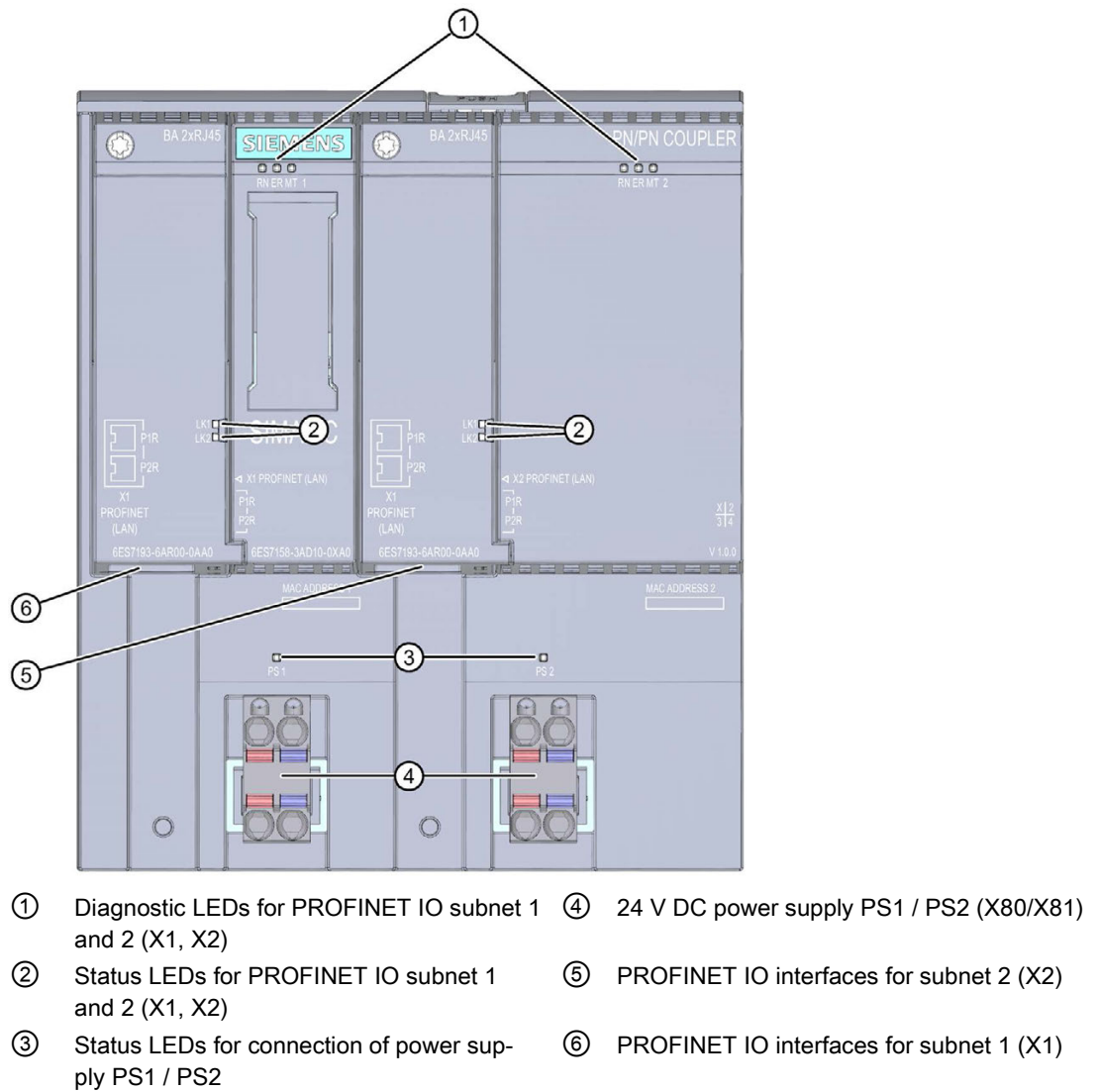

Figure 2-5 Display elements and interfaces of the PN/PN Coupler

X1 PROFINET and X2 PROFINET

For easier assignment of the BusAdapters, they are separated by left and right:

left BusAdapter	right BusAdapter
To the right of it: X1 PROFINET (LAN)	To the right of it: X2 PROFINET (LAN)
For the bus connections: P1R P2R	For the bus connections: P1R P2R

Assembling

3.1 Assembly rules

Mounting position

You can install the PN/PN Coupler under the following conditions:

- for horizontal mounting $T_{max} = 60\text{ }^{\circ}\text{C}$
- for vertical mounting $T_{max} = 50\text{ }^{\circ}\text{C}$

You can find more information on the operating conditions in section General technical specifications (Page 98).

Open equipment

The PN/PN Coupler is open equipment (IP 20). This means that you may only install the PN/PN Coupler in enclosures, cabinets or electrical operating areas. The housings, cabinets and electrical operating rooms must guarantee protection against electric shock and spread of fire. The requirements regarding mechanical strength must also be observed. The housings, cabinets, and electrical operating rooms must not be accessible without a key or tool. Access may only be possible for instructed or authorized personnel.

Mounting technology

You install the PN/PN Coupler on a standard mounting rail (7.5 mm and 15 mm). For non-obstructed mounting, provide a clearance of 10 mm to the left of the module and 20 mm above the module.

3.2 Assembling the PN/PN coupler

Necessary components

- PN/PN Coupler
- SIMATIC BusAdapter
- Strain relief for mechanical load of the PROFINET connections
- Mounting rail:
 - Standard mounting rail (7.5 mm), or
 - Standard mounting rail (15 mm)

You can find the article numbers for the components in the appendix Article numbers and accessories (Page 113).

Installing the PN/PN Coupler on the standard mounting rail

1. Mount the standard mounting rail in such a way that sufficient space remains for installation of and heat dissipation of the module (at least 10 mm on the left and 20 mm above the module).
2. Hook the PN/PN Coupler into the standard mounting rail and swing it downward until you can hear it latch into place on the standard mounting rail.
3. Plug the BusAdapter onto the PN/PN Coupler and screw it on.
4. Connect the PN/PN Coupler as described in section Connecting (Page 27).

Note

Low resistance connection

If the standard mounting rail is mounted on a grounded metal plate or a grounded device support plate, you must ensure a low-resistance connection between the standard mounting rail and base. For example, on painted or anodized metals, use suitable contacting agent or contact washers.

3.3 Disassembling the PN/PN coupler

Uninstalling the PN/PN Coupler

1. Switch off the power supply of the PN/PN Coupler. Disconnect the two 24 V DC connectors PS1 and PS2 from the PN/PN Coupler.
2. Remove the SIMATIC BusAdapter.
3. Press the mounting rail release above the PN/PN Coupler.
4. While pressing the mounting rail release, swing the PN/PN Coupler off of the mounting rail.

3.4 Applying labeling strips

Procedure

Proceed as follows to apply a labeling strip:

1. Label the strip.
2. Insert the labeling strip into the PN/PN Coupler.

3.5 Applying reference identification labels

Procedure

Proceed as follows to apply a reference identification label:

1. Break off the reference identification labels from the sheet.
2. Insert the reference identification labels into the opening on the PN/PN Coupler. The insertion opening is located on the top in each case.

Note

Reference identification label

The printable side of the reference identification label must face forward.

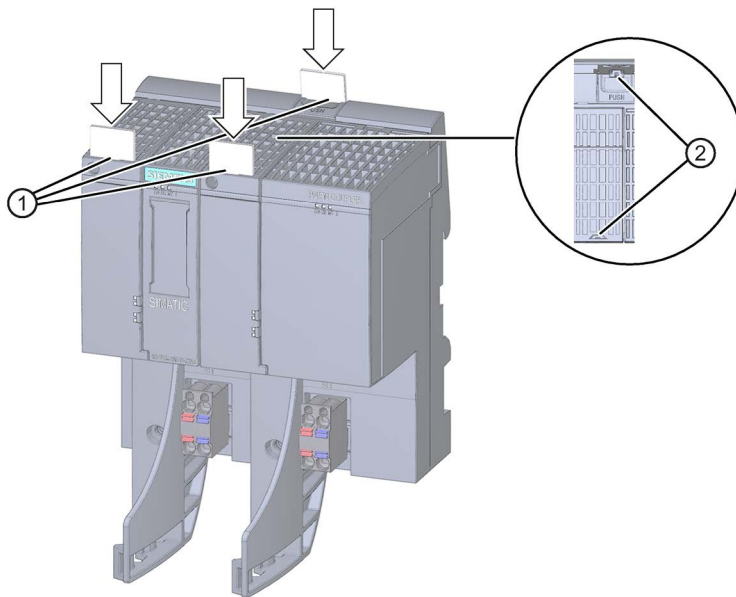

- ① Reference identification labels
- ② Insertion openings

Figure 3-1 Applying reference identification labels

Connecting

4.1 Electrical isolation and grounding

4.1.1 Introduction

Redundant 24 V DC power supply

You can connect the PN/PN Coupler to two independent 24 V DC power supplies. Only one 24 V DC power supply is active at a time. If one power supply fails, the other becomes active automatically. You identify which power supplies (PS1, PS2 or both) are connected and will be diagnosed in the parameter assignment. The connection of one 24 V DC power supply is generally sufficient for operation of the PN/PN Coupler.

Properties of the PN/PN Coupler

- The two PROFINET IO subnets are galvanically isolated from each other.
- The two PROFINET IO subnets are galvanically isolated from the 24 V DC power supply.
- The two 24 V DC power supplies are galvanically isolated from each other.

Ungrounded infeed

It is always possible to configure an ungrounded setup of the PN/PN Coupler as the PN/PN Coupler has no fixed ground connection. The power pack/power supply module for 24 V DC must also be ungrounded and electrically isolated.

4.1.2 General operating rules and regulations

Introduction

For the PN/PN Coupler as a component of a system, special rules and regulations must be adhered to depending on the area of application.

The most important rules, which you must observe for safe integration into a plant or system, are listed below.

Specific application

Observe the safety and accident prevention regulations that are applicable to specific applications (e.g. machine protection guidelines).

EMERGENCY STOP equipment

EMERGENCY STOP devices according to IEC 6204 (coincides with VDE 113) must remain effective during all operating modes of the plant or system.

System startup after certain events

The table below identifies situations you must pay attention to when the system starts up after the occurrence of certain events.

For
<ul style="list-style-type: none"> startup after a voltage dip or power failure startup after bus communication has been interrupted 	no dangerous operating states may occur. If necessary, "EMERGENCY STOP" must be forced!
<ul style="list-style-type: none"> startup after unlocking the emergency stop device startup without the IO controller activating the IO devices 	an uncontrolled or undefined startup must not occur

24 V DC power supply

The table below identifies what you must pay attention to for the 24 V supply.

For ...	you must ensure ...	
Buildings	External lightning protection	Provide lightning protection measures (e.g. Blitzductors)
24 V DC supply cables, signal cables	Internal lightning protection	
24 V supply	Safety extra-low voltage (SELV/PELV) with safe electrical isolation.	

Note

You can find additional information on lightning protection in function manual Installing S7-1500, ET 200MP, ET 200SP, ET 200AL controllers in an interference-proof manner (<https://support.industry.siemens.com/cs/ww/en/view/59193566>).

Protection from external electrical effects

The table below identifies what you must pay attention to for protection from electrical effects or faults.

For ...	you must ensure that ...
all systems in which the modules are integrated	... the system is connected to the protective conductor or the functional earth to discharge electromagnetic interference.
Connection, signal and bus cables	... the cable routing and installation are correct.

4.2 Connections

PN/PN Coupler I/Os

The following figure shows all the connections that you establish to and from the PN/PN Coupler (in the figure, with BA 2×RJ45 BusAdapters):

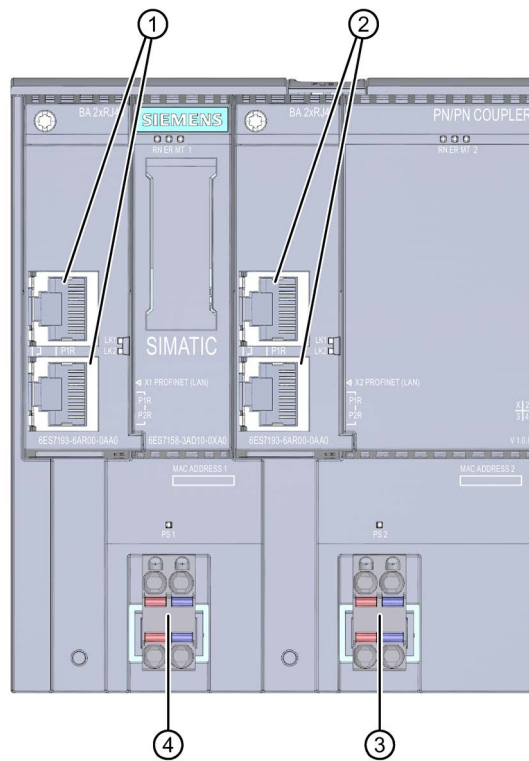

- ① PROFINET IO subnet 1 (X1 PROFINET)
- ② PROFINET IO subnet 2 (X2 PROFINET)
- ③ Power supply 2 (24 V DC)
- ④ Power supply 1 (24 V DC)

Figure 4-1 PN/PN Coupler I/Os

4.3 Connecting the power supply

Required tools

You need a screwdriver with a maximum blade width of 3.5 mm to connect the power supply.

Power supply unit

Only use power supply units of type SELV/PELV with safe electrically isolated functional extra low voltage (≤ 60 V DC).

Redundant power supply

You can supply the PN/PN Coupler from two voltage sources (redundant power supply):

- If one voltage source fails, the PN/PN Coupler automatically switches over to the other voltage source.
- If voltage is applied to both connections (PS1 / PS2), the PN/PN Coupler automatically uses the voltage source of PS1.
- If you only connect the PN/PN Coupler to one power supply, it is preferable to connect it to PS1.

Note

You can evaluate the diagnostics to determine whether the PN/PN Coupler is connected to both 24 V DC power supplies.

Connection for power supply

The power supply connections for the 24 V power supply are located on the front of the PN/PN Coupler. The connections have the following meaning:

Table 4- 1 Connection assignment of power supply for the PN/PN Coupler

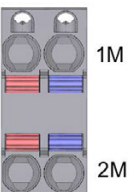
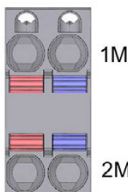
View		Signal name ¹		Description
Connector PS1 on X80	Connector PS2 on X81	Connector PS1	Connector PS2	
		1L+	1L+	24 V DC
		2L+	2L+	24 V DC (for looping through) ²
		1M	1M	Ground
		2M	2M	Ground (for looping through) ²

¹ X80/1L+ and X80/2L+,
X80/1M and X80/2M,
X81/1L+ and X81/2L+,
X81/1M and X81/2M have internal jumpers.

² Maximum 10 A permitted.

The maximum cross-section of the connection is 2.5 mm². A strain relief is not present. The connection plugs offer you the option of looping the power supply uninterrupted, even in unplugged state.

Procedure

To connect the power supply, follow these steps:

1. Strip 10 mm of insulation from the wires.
2. Press the spring release and insert the cable into the round opening of the connection plug as far as it will go. (The connection plugs are plugged into the power supply connection in the delivery state.)

If you have a redundant power supply of the PN/PN Coupler, connect the second power supply to the second connection plug.

If you are using only one voltage source, it is preferable to connect it to PS1.

Wiring rules for PN/PN Coupler

Wiring rules for ...		PN/PN Coupler (supply voltage)
Permitted cable cross-sections of solid cables (Cu)		0.2 to 2.5 mm ² AWG*: 24 to 13
Permitted cable cross-sections of flexible cables (Cu)	Without wire-end ferrule	0.2 to 2.5 mm ² AWG*: 24 to 13
	With wire-end ferrule (with plastic sleeve)***	0.25 mm to 1.5 mm ² ** AWG*: 24 to 16
	With TWIN wire-end ferrule***	0.5 mm to 1 mm ² AWG*: 20 to 17
Stripped length of the wires		8 to 10 mm
Wire-end ferrules in accordance with DIN 46228 with plastic sleeve***		8 and 10 mm long

* AWG: American Wire Gauge

** Wire-end ferrules without plastic sleeve: 0.25 to 2.5 mm²/AWG: 24 to 13

*** See note on wire-end ferrules

Note

Wire-end ferrules

Optimum results with respect to a high-quality and permanent electrical connection with maximum conductor pull forces at the same time can be achieved by using crimping dies, preferably with smooth surfaces, which are provided, for example, with rectangular and trapezoidal crimp cross-sections.

Due to the large number of crimping dies used in the industry, we can recommend others on request. Crimping dies with a pronounced wave profile are unsuitable.

Permissible cable temperature

Note

Permissible cable temperatures

At the maximum ambient temperature of the PN/PN Coupler, you must select sufficiently large wire cross-sections so that the permissible cable temperatures are not exceeded.

Examples:

- At an ambient temperature of 60° C, a current of, for example, 4 A per wire and a cross-section of 1.5 mm² Cu, a connecting conductor must be rated for a temperature range of at least 90° C.
 - At an ambient temperature of 60° C, a current of, for example, 2 A per wire and a cross-section of 1.5 mm² Cu, a connecting conductor must be rated for a temperature range of at least 80° C.
-

4.4 Connecting the BusAdapter

4.4.1 Connecting PROFINET IO to the PN/PN Coupler using BusAdapter BA 2xRJ45

Introduction

You connect PROFINET IO to the PN/PN Coupler using BusAdapter BA 2xRJ45. To do this, screw the BusAdapter BA 2xRJ45 in place on the PN/PN Coupler and fix the PROFINET connection cable in place on the PN/PN Coupler. You can loop PROFINET through via the integrated 2-port switch.

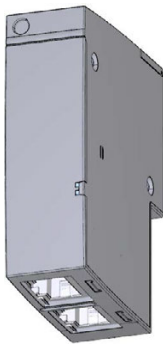

Figure 4-2 BA 2xRJ45 BusAdapter

Required tools

3 to 3.5 mm screwdriver

Required accessories

Please refer to the specifications in the PROFINET Installation Guide (<http://www.profibus.com/>).

Mounting the bus connector

Mount the PROFINET connector according to the instructions in PROFINET Installation Guide (<http://www.profibus.com/>).

Procedure

To connect PROFINET IO to the PN/PN Coupler using BusAdapter BA 2xRJ45, follow these steps:

1. Plug the BusAdapter BA 2xRJ45 onto the PN/PN Coupler.
2. Screw the BusAdapter BA 2xRJ45 to the PN/PN Coupler (1 screw with 0.2 Nm tightening torque). To do this, use a screwdriver with a 3 to 3.5 mm blade.
3. Plug the RJ45 bus connector(s) into the PROFINET port on the BusAdapter BA 2xRJ45.

Note

Installation guidelines for modules with PROFINET IO interfaces

It is only permitted to operate the modules with PROFINET IO interfaces in LAN networks (Local Area Networks) when all connected nodes are equipped and supplied with a SELV/PELV power supply (or have equivalent protection).

A data transfer point that guarantees this degree of safety is prescribed for connection to the WAN (Wide Area Network).

4.4.2 Connecting PROFINET IO to the PN/PN Coupler using BusAdapter BA 2xFC

Introduction

You connect PROFINET IO to the PN/PN Coupler using BusAdapter BA 2xFC. To do this, screw the BusAdapter BA 2xFC with the connected PROFINET connection cable in place on the PN/PN Coupler. You can loop PROFINET through via the integrated 2-port switch.

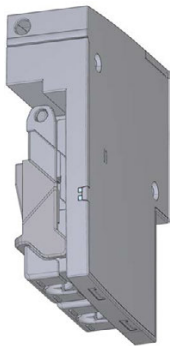

Figure 4-3 BA 2xFC BusAdapter

Required tools

3 to 3.5 mm screwdriver

Required accessories

- If you use Fast Connect Cable, we recommend the Industrial Ethernet Fast Connect Stripping Tool (6GK1901-1GA00) with green knife cassette (6GK1901-1B...). This guarantees fast and safe stripping.
- Fast Connect Cable (recommended types):
 - IE FC TP Standard Cable GP 2x2 (6XV1840-2AH10)
 - IE FC TP Trailing Cable 2x2 (6XV1840-3AH10)
 - IE FC TP Marine Cable (6XV1840-4AH10)
 - IE FC TP Flexible Cable GP 2x2 (6XV1870-2B)
 - IE FC TP Trailing Cable 2x2 (6XV1870-2D)
 - IE TP Torsion Cable 2x2 (6XV1870-2F)
 - FC TP FRNC Cable GP (6XV1871-2F)
 - IE FC TP Food Cable GP 2x2 (6XV1871-2L)
 - IE FC TP Festoon Cable 2x2 (6XV1871-2S)
- Please refer to the specifications in the PROFINET Installation Guide (<http://www.profibus.com/>).

Procedure

To connect PROFINET IO to the PN/PN Coupler using BusAdapter BA 2xFC, follow these steps:

1. Strip insulation from the sheath of the PROFINET connection cable as follows:

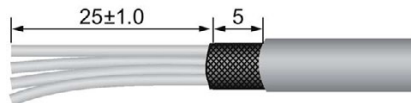
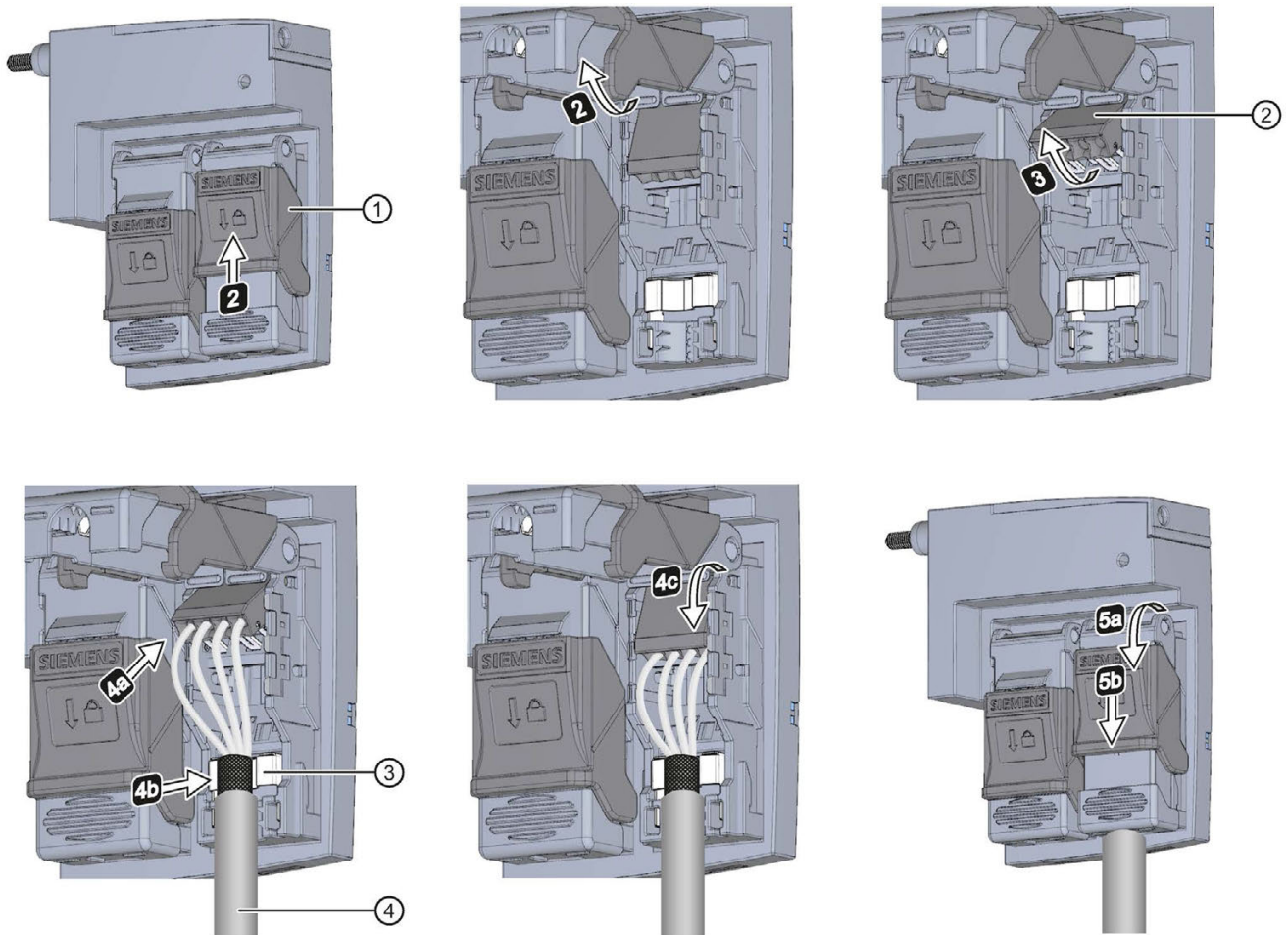

Figure 4-4 PROFINET connecting cable

2. Pull back the locking slide and fold up the cover of the connection element.
3. Pull up the wire guide as far as it will go.
4. Insert the unstripped single wires of the PROFINET connecting cable (according to the attached color coding) into the wire guide and press the guide down **firmly** as far as it will go.

5. Close the cover of the connection element and push the locking slide forwards as far as it will go.
6. Plug and screw the BA 2×FC BusAdapter on the PN/PN Coupler (1 screw with 0.2 Nm tightening torque). To do this, use a screwdriver with a 3 to 3.5 mm blade.



- | | | | |
|---|---------------|---|---------------------------|
| ① | Locking slide | ③ | Shield contact |
| ② | Wire guide | ④ | PROFINET connecting cable |

Figure 4-5 Connection of the PROFINET IO BusAdapter BA 2×FC to the PN/PN Coupler

Note

Installation guidelines for modules with PROFINET IO interfaces

Only when all connected nodes are equipped and supplied with a SELV/PELV power supply (or have equivalent protection), is it permitted to operate the modules with PROFINET IO interfaces in LAN networks (Local Area Networks).

A data transfer point that guarantees this degree of safety is prescribed for connection to the WAN (Wide Area Network).

4.4.3 Connecting PROFINET IO to the PN/PN Coupler using BusAdapter BA 2xSCRJ

Introduction

Using BusAdapter BA 2xSCRJ, you connect PROFINET IO to the PN/PN Coupler optically with fiber-optic cables via an SC RJ connector. To do this, screw the BusAdapter BA 2xSCRJ in place on the PN/PN Coupler and insert the SC RJ connector. You can loop PROFINET through optically via the integrated 2-port switch.

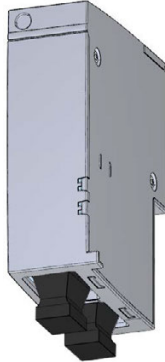

Figure 4-6 BA 2xSCRJ BusAdapter

Required tools

3 to 3.5 mm screwdriver

Required accessories

- Connector for PROFINET connection: IE SC RJ POF plug
- Fiber-optic cable:
 - IE POF standard cable (6XV1874-2A)
 - IE POF trailing cable (6XV1874-2B)
 - IE PCF standard cable (6XV1861-2A)
 - IE PCF trailing cable (6XV1861-2C)
 - IE PCF trailing cable GP (6XV1861-2D)

Requirements

- Prepare the IE POF cables with the connectors IE SC RJ POF Plug or IE SC RJ PCF Plug. For detailed information, refer to the assembly instructions POF Fiber-optic Cables with IE Termination Kit SC RJ POF Plug (A5E00351141) or PCF Fiber-optic Cables with the IE Termination Kit SC RJ PCF Plug (A5E00835119).
- When installing the fiber-optic cable, make sure the bending radius is not less than permitted:
 - IE POF/PCF standard cable: 150 mm
 - IE POF/PCF trailing cable: 60 mm
- The maximum lengths of the fiber-optic cables are as follows:
 - IE POF standard cable: 50 m
 - IE POF trailing cable: 50 m
 - IE POF standard cable: 100 m
 - IE PCF trailing cable: 100 m
- When the PN/PN Coupler is the last device of the fiber-optic cable network, the unoccupied fiber-optic cable interface must be closed with a blanking plug. The blanking plugs are inserted in the PROFINET sockets of the BusAdapter in delivery state.

Procedure

To connect PROFINET IO to the PN/PN Coupler using BusAdapter BA 2×SCRJ, follow these steps:

1. Plug the BusAdapter BA 2×SCRJ on the PN/PN Coupler.
2. Screw the BusAdapter BA 2×SCRJ to the PN/PN Coupler (1 screw with 0.2 Nm tightening torque). To do this, use a screwdriver with a 3 to 3.5 mm blade.
3. Remove the blanking plugs from the PROFINET sockets.
4. Hold the prepared connector by the housing and insert it into the PROFINET socket on the BusAdapter BA 2×SCRJ until you hear it click into place. The connectors are coded to ensure correct connection.

 CAUTION
Risk of damage to eyes
Do not look directly into the opening of the optical transmitter diodes. The emitted light beam can damage your eyes.

Reusing fiber-optic cable

Note

If you are reusing fiber-optic cables, you must shorten both fiber-optic cores by the amount of the curved lengths and reassemble the connectors. This will prevent any attenuation losses caused by re-bent, heavily stressed portions of the fiber-optic cores.

Reference

For more information on the installation guidelines for fiber-optic cables, refer to the SIMATIC NET PROFIBUS Network Manual (<http://support.automation.siemens.com/WW/view/en/35222591>).

4.4.4 Connecting PROFINET IO to the PN/PN Coupler using BusAdapter BA SCRJ/FC

Introduction

You connect PROFINET IO to the PN/PN Coupler using BusAdapter BA SCRJ/FC:

- Optically with fiber-optic cables (FOC) with an SC RJ connector (port 1) or
- Electrically with direct connection of the Fast Connect bus cable (port 2)

To do this, screw the BusAdapter BA SCRJ/FC with the connected Fast Connect bus cable in place on the PN/PN Coupler and insert the SC RJ connector.

You loop through the PROFINET IO via the integrated 2-port switch. You can use any port of the BusAdapter for feeding or for looping through. The integrated media converter converts the signals automatically.

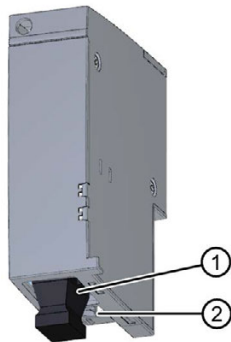

- ① Fiber-optic cable SCRJ
- ② FastConnect FC

Figure 4-7 BA SCRJ/FC BusAdapter

Connecting the SC RJ connector

You can find additional information on required tools and accessories, requirements and procedures in section Connecting PROFINET IO to PN/PN Coupler using BusAdapter BA 2xSCRJ (Page 38).

Connecting a Fast Connect bus cable

You can find more information about the required tools, accessories and procedures in section Connecting PROFINET IO to the PN/PN Coupler using BusAdapter BA 2×FC (Page 35).

4.4.5 Connecting PROFINET IO to the PN/PN Coupler using BusAdapter BA SCRJ/RJ45

Introduction

You connect PROFINET IO to the PN/PN Coupler using BusAdapter BA SCRJ/RJ45:

- Optically with fiber-optic cables (FOC) with an SC RJ connector (port 1) or
- Electrically with a standard RJ45 connector (port 2)

To do this, screw the BusAdapter BA SCRJ/RJ45 in place on the PN/PN Coupler and insert the SC RJ connector or RJ45 connector.

You loop through the PROFINET IO via the integrated 2-port switch. You can use any port of the BusAdapter for feeding or for looping through. The integrated media converter converts the signals automatically.

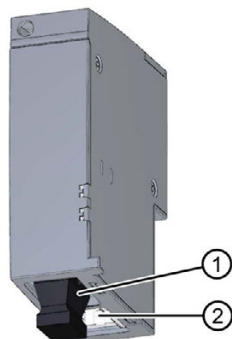

- ① Fiber-optic cable SCRJ
- ② RJ45

Figure 4-8 BA SCRJ/RJ45 BusAdapter

Connecting the SC RJ connector

You can find additional information on required tools and accessories, requirements and procedures in section Connecting PROFINET IO to PN/PN Coupler using BusAdapter BA 2xSCRJ (Page 38).

Connecting the RJ45 connector

You can find additional information about the required tools, accessories and procedures in section Connecting PROFINET IO to the PN/PN Coupler using BusAdapter BA 2xRJ45 (Page 34).

4.4.6 Connecting PROFINET IO to the PN/PN Coupler using BusAdapter BA 2xLC

Introduction

Using BusAdapter BA 2xLC, you connect PROFINET IO to the PN/PN Coupler optically with glass fiber-optic cable via an LC connector. To do this, screw the BusAdapter BA 2xLC in place on the PN/PN Coupler and insert the LC connector. You can loop PROFINET through optically via the integrated 2-port switch.

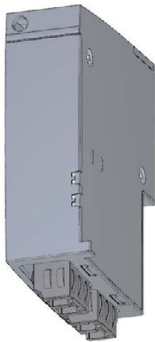

Figure 4-9 BA 2xLC BusAdapter

Required tools

3 to 3.5 mm screwdriver

Required accessories

- If you prepare the FC FO cable with the IE FC FO LC plug, we recommend the FC FC FO Termination Kit (LC) (6GK1900-0RL00-0AA0). You can cleave the glass fiber precisely using the FC FO Termination Kit (LC).

 CAUTION
Cleaving the glass fiber
<ul style="list-style-type: none"> • Wear protective glasses during the cleaving process. • Dispose of the remaining fibers in a suitable waste container.

- Connector for PROFINET connection: IE FC FO LC Plug (10 duplex plugs: 6GK1900-1RB00-2AB0)
- Fiber-optic cable:
 - IE FC FO Standard Cable GP (62.5/200/230) (6XV1847-2A)
 - IE FC FO Trailing Cable (62.5/200/230) (6XV1847-2C)
 - IE FC FO Robust Cable (6XV1873-5Rxx)
 - IE FC FO Standard Cable (6XV1873-3Axx)

Requirements

- Prepare the IE FC FO cable with the IE FC FO LC plug connectors. For detailed instructions, refer to the assembly instructions Preparing IE FC FO Cable with the plug-in connector IE FC FO LC Plug (A5E36312721).
- When installing the fiber-optic cable, make sure the bending radius is not less than permitted:
 - IE FC FO Standard Cable GP (62.5/200/230): 70 mm
 - IE FC FO Trailing Cable (62.5/200/230) (6XV1847-2C): 88 mm
- The maximum lengths of the fiber-optic cables are as follows:
 - IE FC FO Standard Cable GP (62.5/200/230): 3 km
 - IE FC FO Trailing Cable (62.5/200/230): 3 km
- When the PN/PN Coupler is the last device of the fiber-optic cable network, the unoccupied fiber-optic cable interface must be closed with a blanking plug. The blanking plugs are inserted in the PROFINET sockets of the BusAdapter in delivery state.

Procedure

To connect PROFINET IO to the PN/PN Coupler using BusAdapter BA 2xLC, follow these steps:

1. Plug the BusAdapter BA 2xLC onto the PN/PN Coupler.
2. Screw the BusAdapter BA 2xLC to the PN/PN Coupler (1 screw with 0.2 Nm tightening torque). To do this, use a screwdriver with a 3 to 3.5 mm blade.
3. Remove the blanking plugs from the PROFINET connections.
4. Hold the prepared connector by the housing and insert it into the PROFINET socket on the BusAdapter BA 2xLC until you hear it click into place. The connectors are coded to ensure correct connection.

 CAUTION
Risk of damage to eyes
Do not look directly into the opening of the optical transmitter diodes. The emitted light beam can damage your eyes.

Reusing fiber-optic cable

Note

If you are reusing fiber-optic cables, you must shorten both fiber-optic cores by the amount of the curved lengths and reassemble the connectors. This will prevent any attenuation losses caused by re-bent, heavily stressed portions of the fiber-optic cores.

Reference

You can find additional information on the installation guidelines for fiber-optic cables in manual Manual SIMATIC NET PROFIBUS Networks (<http://support.automation.siemens.com/WW/view/en/35222591>).

4.4.7 Connecting PROFINET IO to the PN/PN Coupler using BusAdapter BA LC/RJ45

Introduction

You connect PROFINET IO to the PN/PN Coupler using BusAdapter BA LC/RJ45:

- Optically with glass fiber-optic cables with an LC connector (port 1) or
- Electrically with a standard RJ45 connector (port 2)

To do this, screw the BusAdapter BA LC/RJ45 in place on the PN/PN Coupler and insert the LC connector or RJ45 connector.

You loop through the PROFINET IO via the integrated 2-port switch. You can use any port of the BusAdapter for feeding or for looping through. The integrated media converter converts the signals automatically.

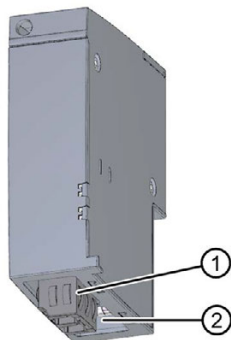

- ① Glass fiber-optic cable LC
- ② RJ45

Figure 4-10 BA LC/RJ45 BusAdapter

Attaching LC connectors

You can find additional information on required tools and accessories, requirements and the procedures in section Connecting PROFINET IO to PN/PN Coupler using BusAdapter BA 2xLC (Page 42).

Connecting the RJ45 connector

You can find additional information about the required tools, accessories and procedures in section Connecting PROFINET IO to the PN/PN Coupler using BusAdapter BA 2xRJ45 (Page 34).

4.4.8 Connecting PROFINET IO to the PN/PN Coupler using BusAdapter BA LC/FC

Introduction

You connect PROFINET IO to the PN/PN Coupler using BusAdapter BA LC/FC:

- Optically with glass fiber-optic cables with an LC connector (port 1) or
- Electrically with direct connection of the Fast Connect bus cable (port 2)

To do this, screw the BusAdapter BA LC/FC in place on the connected Fast Connect bus cable on the PN/PN Coupler and insert the LC connector.

You loop through the PROFINET IO via the integrated 2-port switch. You can use any port of the BusAdapter for feeding or for looping through. The integrated media converter converts the signals automatically.

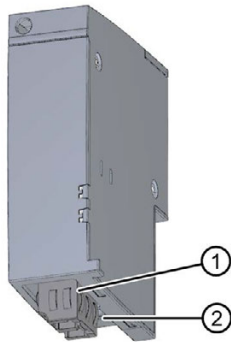

- ① Glass fiber-optic cable LC
- ② FastConnect FC

Figure 4-11 BA LC/FC BusAdapter

Attaching LC connectors

You can find additional information on required tools and accessories, requirements and the procedures in section Connecting PROFINET IO to PN/PN Coupler using BusAdapter BA 2xLC (Page 42).

Connecting a Fast Connect bus cable

You can find more information about the required tools, accessories and procedures in section Connecting PROFINET IO to the PN/PN Coupler using BusAdapter BA 2xFC (Page 35).

4.5 Connecting PROFINET IO

PROFINET IO with BusAdapter BA 2×RJ45

The assignment corresponds to the Ethernet standard for an RJ45 connector.

- Port P1: When autonegotiation is deactivated, the RJ45 socket has the terminal device assignment MDI (normal pin assignment).
- Port P2: When autonegotiation is deactivated, the RJ45 socket has the switch assignment MDI-X (crossed pin assignment), which means you should ideally use a cross-over cable.
- The following applies to both ports: When autonegotiation is activated, autocrossing is active and the RJ45 socket either has the terminal equipment assignment MDI or the switch assignment MDI-X.

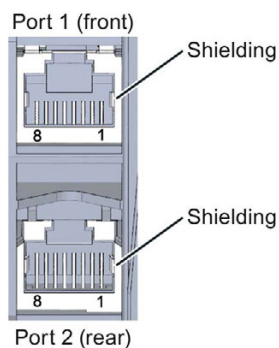
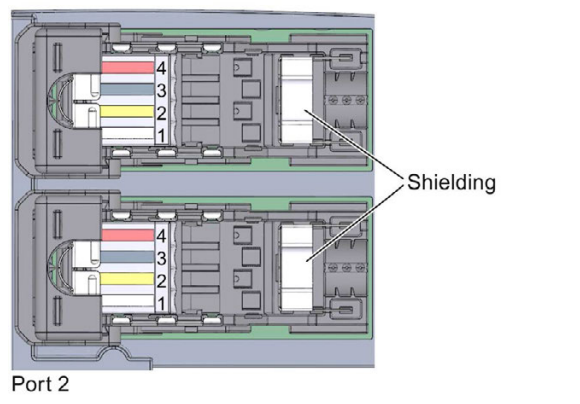

Figure 4-12 Pin assignment

PROFINET IO with BusAdapter BA 2×FC

The following table shows the signal name and description of the pin assignment of BusAdapter BA 2×FC.

Table 4- 2 PROFINET IO pin assignment with BusAdapter BA 2×FC

View	Signal name	Description	
 <p>Port 1</p> <p>Port 2</p> <p>Shielding</p>	1	RD_N	Receive Data -
	2	TD_N	Transmit Data -
	3	RD	Receive Data +
	4	TD	Transmit Data +

PROFINET IO with BusAdapter BA 2×SCRJ

The following table shows the signal name and description of the pin assignment of BusAdapter BA 2×SCRJ.

Table 4- 3 PROFINET IO pin assignment with BusAdapter BA 2×SCRJ

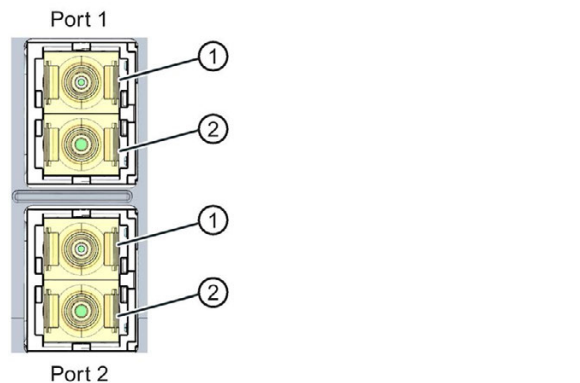
View	Signal name	Description
 <p>Port 1</p> <p>Port 2</p>	①	Receiver/Receive Data
	②	Sender/Transmit Data

PROFINET IO with BusAdapter BA SCRJ/RJ45

The following table shows the signal name and description of the pin assignment of BusAdapter BA SCRJ/RJ45.

Table 4- 4 PROFINET IO pin assignment with BusAdapter BA SCRJ/RJ45

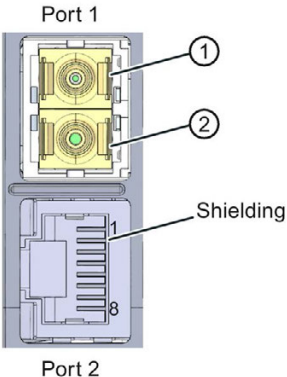
View	Signal name	Description
	①	Receiver/Receive Data
	②	Sender/Transmit Data
RJ45, Port 2 <ul style="list-style-type: none"> When autonegotiation is deactivated, the RJ45 socket is allocated as a switch (MDI-X), which means you best use a cross-over cable. When autonegotiation is activated, auto-crossing is in effect and the RJ45 socket is allocated either as data terminal equipment (MDI) or a switch (MDI-X). 		

PROFINET IO with BusAdapter BA SCRJ/FC

The following table shows the signal name and description of the pin assignment of BusAdapter BA SCRJ/FC.

The connections of the BusAdapter BA SCRJ/FC are shown individually for a clearer overview.

Table 4- 5 PROFINET IO pin assignment with BusAdapter BA SCRJ/FC

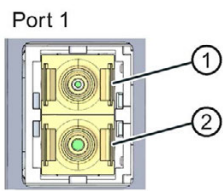
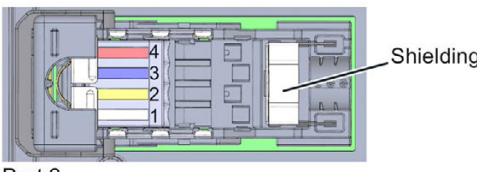
View	Signal name	Description	
	①	Receiver/Receive Data	
	②	Sender/Transmit Data	
	1	RD_N	Receive Data -
	2	TD_N	Transmit Data -
	3	RD	Receive Data +
	4	TD	Transmit Data +

PROFINET IO with BusAdapter BA 2xLC

The following table shows the signal name and description of the pin assignment of BusAdapter BA 2xLC.

Table 4- 6 PROFINET IO pin assignment with BusAdapter BA 2xLC

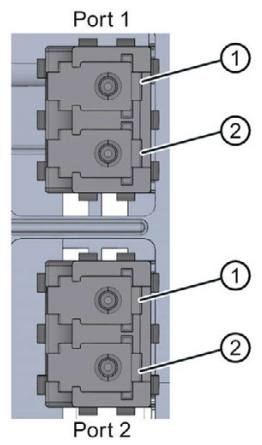
View	Signal name	Description
	①	Receiver/Receive Data
	②	Sender/Transmit Data

PROFINET IO with BusAdapter BA LC/RJ45

The following table shows the signal name and description of the pin assignment of BusAdapter BA LC/RJ45.

Table 4- 7 PROFINET IO pin assignment with BusAdapter BA LC/RJ45

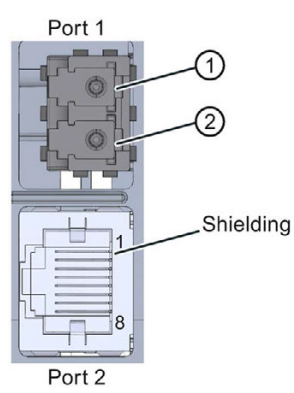
View	Signal name	Description
	①	Receiver/Receive Data
	②	Sender/Transmit Data
	RJ45, Port 2 <ul style="list-style-type: none"> When autonegotiation is deactivated, the RJ45 socket is allocated as a switch (MDI-X), which means you best use a cross-over cable. When autonegotiation is activated, auto-crossing is in effect and the RJ45 socket is allocated either as data terminal equipment (MDI) or a switch (MDI-X). 	

PROFINET IO with BusAdapter BA LC/FC

The following table shows the signal name and description of the pin assignment of BusAdapter BA LC/FC.

The connections of the BusAdapter BA LC/FC are shown individually for a clearer overview.

Table 4- 8 PROFINET IO pin assignment with BusAdapter BA LC/FC

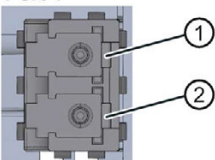
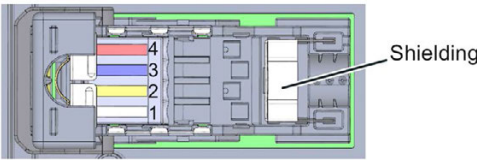
View	Signal name	Description	
Port 1 	①	Receiver/Receive Data	
	②	Sender/Transmit Data	
	1	RD_N	Receive Data -
	2	TD_N	Transmit Data -
	3	RD	Receive Data +
	4	TD	Transmit Data +

4.6 Strain relief

4.6.1 Product overview

Article number

6ES7193-6RA00-1AN0 (VPE: 5 units strain-relief assembly including screws)

View

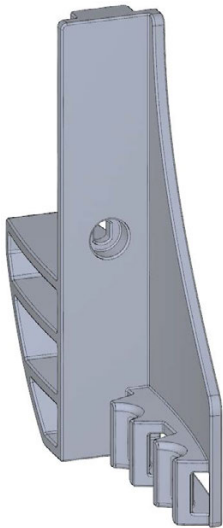

Figure 4-13 Strain relief

Properties

- The strain relief is a mechanical protective device for the electrical PROFINET cables on the BusAdapter.
- The strain relief is suitable for all optical and electrical PROFINET cables of the BusAdapter.
- The strain relief is an optional accessories.
- The cable ties are not included in the delivery. We recommend cable ties with a width of 4.8 mm. The maximum width is 7.0 mm. The length of the cable tie is at least 60 mm.

4.6.2 Installing

Requirement

- The PROFINET cables are not plugged into the BusAdapter. The mounting of the strain relief is made more difficult when PROFINET cables are plugged in.
- BusAdapter and strain relief can be mounted independently.

Tools required

Screwdriver TX10 (Torx).

Procedure

To install the strain relief, follow these steps:

1. Press the strain relief below the BusAdapter seat of the PROFINET device.
2. Fasten the strain relief (1 screw with 0.7 to 0.8 Nm tightening torque).
3. Plug the BusAdapter into the PROFINET device.
4. Screw the BusAdapter to the PROFINET device (1 screw with 0.2 Nm tightening torque).
5. Fasten each PROFINET cable individually to the strain relief with the cable ties.

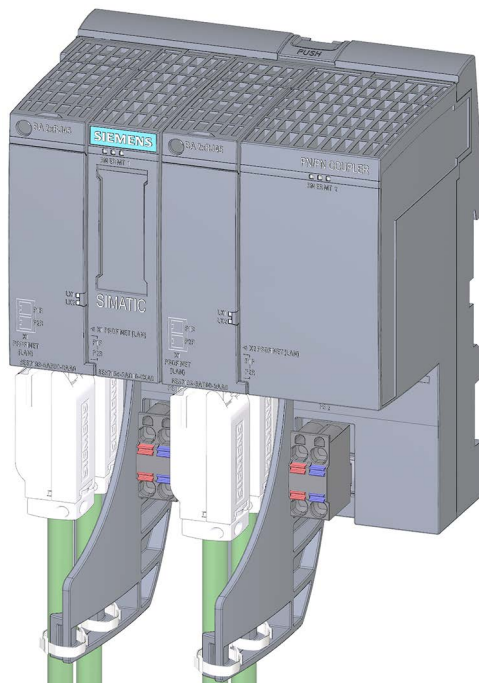
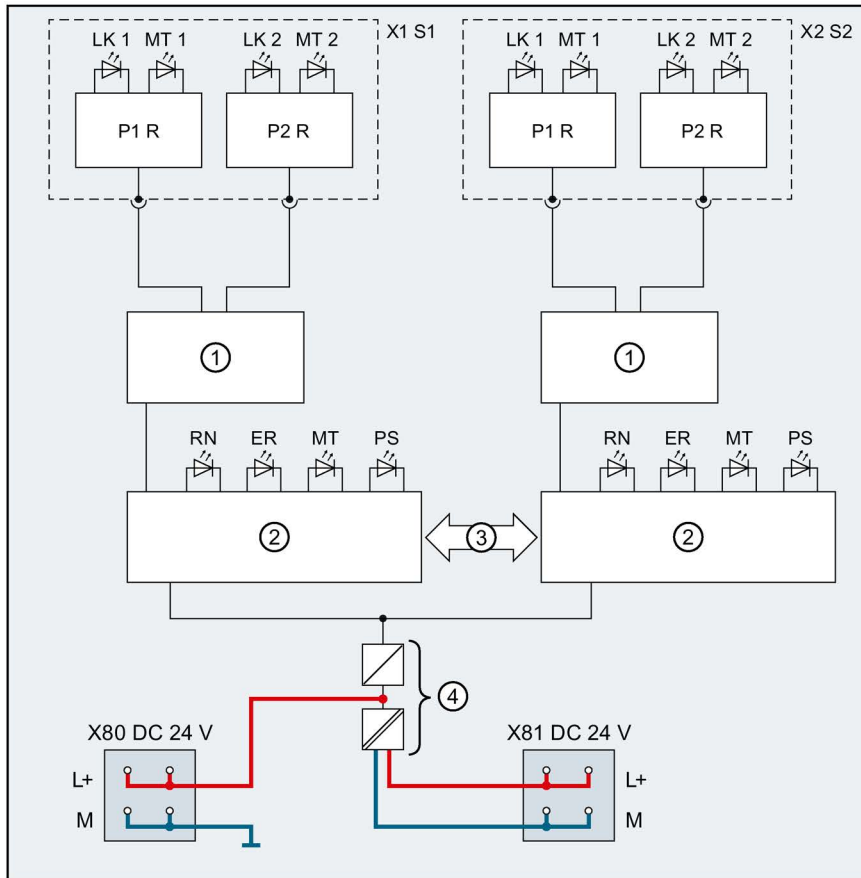

Figure 4-14 Installing strain relief

4.7 Block diagram

Block diagram

The following figure shows the block diagram of the PN/PN Coupler.



- | | | | |
|---------|--------------------------------------|---------|----------------------------|
| ① | Switch (component of the controller) | L+ | 24 V DC supply voltage |
| ② | Controller, right and left | M | Ground |
| ③ | Coupling | LK 1, 2 | Link LED |
| ④ | Internal power supply | MT 1, 2 | FiberOptic LED (SCRJ port) |
| 24 V DC | Supply voltage infeed | RN | RUN LED (green) |
| X1, X2 | BusAdapter | ER | ERROR LED (red) |
| P1 R | PROFINET interface X1, X2 Port 1 | MT | MAINT LED (yellow) |
| P2 R | PROFINET interface X1, X2 Port 2 | PS | POWER LED (green) |

Figure 4-15 PN/PN Coupler block diagram

Configuring, parameter assignment and commissioning

5

5.1 Configuring and commissioning of the PN/PN coupler (overview)

Overview

The following table shows the steps you must perform up to and including commissioning.

Table 5- 1 Procedure for configuring and commissioning the PN/PN Coupler

Step	Action	Content	Additional information in section
1	Mounting	Mount the PN/PN Coupler on the mounting rail.	Assembling (Page 23)
2	Connecting	Connect the PN/PN Coupler to the power supply and PROFINET IO.	Connecting (Page 27)
3	Configuring the PN/PN Coupler	Configure the PN/PN Coupler with the STEP 7 TIA Portal	Configuring the PN/PN Coupler with STEP 7 TIA Portal (Page 58)
		Configuring with a different configuration tool	Configuring the PN/PN Coupler with a different configuration tool (Page 61)
4	Parameter assignment	Assign the PN/PN Coupler parameters with a different configuration tool.	Parameters (Page 62) and STEP 7 online help
5	Commissioning the PN/PN Coupler	Switch on the PN/PN Coupler and download the configuration.	Commissioning the PN/PN coupler (Page 64)

5.2 Requirements

To configure the PN/PN Coupler, you need one of the following components:

- STEP 7 TIA Portal V15 or higher
- GSD file of the PN/PN Coupler The GSD files can be downloaded on the Internet (<http://support.automation.siemens.com/WW/view/en/23742537>).

5.3 Assignment of the modules

Introduction

You configure the PN/PN Coupler by configuring both sides separately.

Note

Assignment of the virtual modules

When coupling the two subnets, note the permitted assignment of modules:
 For each module in a subnet, you must have configured a corresponding module of the same length on the same slot in the other subnet.

Table 5-2 Assignment of the modules in the "IO Modules" module operating mode

Modules network side 1	Assigned IO modules network side 2
Output module (OUT)	Input module (IN)
Output module (OUT)	MSI coupling module (MSI)
Input module (IN)	Output module (OUT)
Input module (IN)	MSO coupling module (MSO)
PROFIsafe IN/OUT ¹	PROFIsafe IN/OUT ¹
MSI/MSO ²	MSI/MSO ²
MSI/MSO ³	PROFIsafe IN/OUT ³
MSO coupling module (MSO)	Input module (IN)
MSO coupling module (MSO)	MSI coupling module (MSI)
MSI coupling module (MSI)	Output module (OUT)
MSI coupling module (MSI)	MSO coupling module (MSO)
Local MSO module (MSO Local)	---
Local MSO module (MSO Local)	Local MSO module (MSO Local)
---	Local MSO module (MSO Local)
RD WRITE STO	RD READ STO
RD READ STO	RD WRITE STO
RD WRITE PUB	RD READ PUB
RD READ PUB	RD WRITE PUB

- ¹ Only for PROFIsafe communication
- ² Can also be used as IN/OUT module if only one subslot is configured
- ³ Is only permitted in IO Modules (ext. comp. V3.x) operating mode

PROFIsafe module

You have to observe the following for PROFIsafe IN/OUT:

- Only the PROFIsafe IN/OUT must be used for failsafe communication in module operating mode "IO Modules".
- The data status byte is not available, because the validity of the coupled user data is guaranteed by the mechanisms of the failsafe communication.

We recommend that you do not use the respective modules for other applications due to the missing data status byte (DS).

Note

Only with GSD

The PROFIsafe modules can only be configured with GSD.

5.4 Configuring the PN/PN Coupler with STEP 7 TIA Portal

5.4.1 Configuring the PN/PN Coupler with STEP 7 TIA Portal

Configuring the PN/PN Coupler

1. Start STEP 7 TIA Portal with your project and open the hardware configuration.
2. Using drag-and-drop, move PN/PN Coupler 6ES7158-3AD10-0XA0 from the Network components/Gateways directory of the hardware catalog onto the PROFINET network.
3. Double-click the symbol of the PN/PN Coupler.
4. Assign a device name for the PN/PN Coupler and confirm with OK.

The device name must be unique on the Ethernet subnet. The device name must comply with the DNS conventions. You can find more information about assigning the device name in the STEP 7 online help.

5. For configuring the left side of the bus (X1), click the symbol of the PN/PN Coupler.
6. Open the "Module parameters/Transfer mapping" table in PNP Coupler.x1. Create up to 16 slots of the PN/PN Coupler in the table. Note the permitted assignment of modules (see Assignment of the modules (Page 56)).

Note

Assigning the device name

Assign the device name to the PN/PN Coupler online.

Result

Configuring is complete for both sides of the PN/PN Coupler.

Coupling both subnets

The two sides are constantly kept consistent in the TIA Portal. Changes to side X1 lead automatically to the adaptation of side X2, and vice versa. This requires that the two bus sides X1 and X2 are in the same project or in a multi-project.

Recommended procedure when you make changes on the couple partner:

1. Perform the changes (e.g. add I/O modules).
2. Execute the "Save and compile" function for both bus sides.

Result: The configuration is consistent.

5.4.2 Example: Configuring with STEP 7 TIA Portal

Task

You want to transfer I/O data and data records to or from the IO controller:

Bus side X1	Bus side X2
2 bytes inputs (IN 2 bytes)	2 bytes outputs (OUT 2 bytes)
8 bytes outputs (OUT 8 bytes)	8 bytes inputs (IN 8 bytes)
8 bytes inputs (IN 8 bytes)	8 bytes outputs (OUT 8 bytes)
2 bytes outputs (OUT 2 bytes)	2 bytes inputs (IN 2 bytes)
6 byte inputs / 12 byte outputs (IN/OUT 6 bytes / 12 bytes)	12 bytes inputs / 6 bytes outputs (IN/OUT 12 bytes / 6 bytes)
RD READ STO	RD WRITE STO
RD WRITE STO	RD READ STO

Configuring the PN/PN Coupler in subnet 1 in STEP 7 TIA Portal

The configuration of the PN/PN Coupler in subnet 1 (bus side X1) looks like the following:

	Transfer area	Virtual slot	Type	I-length		Q-length		I-address	Q-address
					Byte(s)		Byte(s)		
1	Transfer area_1	1	IN	2	Byte(s)				
2	Transfer area_2	2	OUT			8	Byte(s)		
3	Transfer area_3	3	IN	8	Byte(s)				
4	Transfer area_4	4	OUT			8	Byte(s)		
5	Transfer area_5	5	IN/OUT	6	Byte(s)	12	Byte(s)		
6	Transfer area_6	6	RECORD_READ_STO	5	Byte(s)	1	Byte(s)		
7	Transfer area_7	7	RECORD_WRITE_STO	2	Byte(s)				

Configuring the PN/PN Coupler in subnet 2 in STEP 7 TIA Portal

The configuration of the PN/PN Coupler is made exactly opposite the configuration in subnet 1. This configuration takes place at the same time in the "Mapping of IO data from PROFINET interface X1 to X2". The configuration of the PN/PN Coupler in subnet 2 (bus side X2) looks like the following:

Transfer area	Virtual slot	Type	I-length		Q-length		I-address	Q-address	Access
Transfer area_1	1	OUT			2	Byte(s)		10...11	PLC_2
Transfer area_2	2	IN	8	Byte(s)			8...15		PLC_2
Transfer area_3	3	OUT			8	Byte(s)		12...19	PLC_2
Transfer area_4	4	IN	8	Byte(s)			16...23		PLC_2
Transfer area_5	5	IN/OUT	12	Byte(s)	6	Byte(s)	24...35	20...25	PLC_2
Transfer area_6	6	RECORD_WRITE_STO	2	Byte(s)			36...37		PLC_2
Transfer area_7	7	RECORD_READ_STO	5	Byte(s)	1	Byte(s)	38...42	26	PLC_2

Result

You have configured your I/O data and data records in the PN/PN Coupler.

5.4.3 Generating a GSD file with STEP 7 TIA Portal

Generating a GSD file

You have finished configuring your PN/PN Coupler and want to generate a GSD file.

1. You have pressed the "Export" button for a GSD file under "Mapping of IO data from PROFINET interface X1 to X2".
2. The "Export device description (GSD)" function is offered for X1 and X2. Enter the path and the file name.
3. Select "Export".

Result: The GSD file has been created.

Generating a GSD file for only one side

You have finished configuring your PN/PN Coupler and want to generate a GSD file for side X1 or X2.

1. Click the "Export" button in the "Export generic station description file (GSD)" field in the transfer mapping.
2. The "Export generic station description (GSD)" for X1 or X2 is offered. Enter the path and the file name.
3. Select "Export".

Result: The GSD file has been created for one PROFINET side.

5.5 Configuring the PN/PN Coupler with a different configuration tool

Introduction

You configure the PN/PN Coupler using a GSD file. You integrate the PN/PN Coupler as an IO device in your configuration tool using this file. The GSD files can be downloaded on the Internet (<http://support.automation.siemens.com/WWW/view/en/23742537>).

GSD file

The following GSD file is available for the PN/PN Coupler:

GSDML-V2.32-Siemens-PNPNIOC-"Date in format yyyyymmdd".xml

You can find more information on the procedure with GSD files in the STEP 7 online help.

Configuring the PN/PN Coupler

You configure the PN/PN Coupler with your configuration tool like any other IO device on PROFINET IO.

Download the complete GSD file for the PN/PN Coupler to your configuration tool. You configure the PN/PN Coupler separately in each of the two subnets. Select the IO device labeled with X1 or X2 in each case.

Note the following when assigning the device name for the PN/PN Coupler: The device name must be unique on the Ethernet subnet. The device name must comply with the DNS conventions.

When configuring using a GSD file, various modules are available for the data record transfer, each of which has a fixed length. Support for configuring the coupling of the two subnets (as is available in STEP 7) is not possible when configuring using a GSD file. Note the permitted assignment of modules (see Assignment of the modules (Page 56)).

IO modules in two versions

The GSD offers IO modules in two versions:

- IO Modules (recommended)

The validity of the coupled user data is displayed in the input data due to the included data status byte (DS).

- IO Modules (ext. comp. V3.x)

In this operating mode, monitoring of the user data validity is ensured by the PROFINET system. To do so, the information for evaluation of user data validity is provided by the organization blocks (error OB 85 or 122) in the SIMATIC CPU. User ReturnOfSubmodule interrupts provide information about the validity of the IO data of a slot. To do so, the user data flags of the slots are evaluated. If a user data flag changes from "Bad" to "Good", a ReturnOfSubmodule interrupt is produced which results in a OB 83 being called up within a SIMATIC CPU. The bus side of the PN/PN Coupler that has already received its configuration generates a ReturnOfSubmodule interrupt for each matching slot in the configuration when the other bus side is being configured.

5.6 Parameters

In operating mode IO Modules (ext. comp. V3.x), the PN/PN Coupler is compatible with the PN/PN Coupler V3.x.

Note

IO Modules are not compatible with IO Modules (ext. comp. V3.x)

It is not permitted to mix operating modes on the local or the partner interface.

This must also be ensured when using the PN/PN Coupler as PROFINET shared device with multiple controllers.

5.6 Parameters

Table 5- 3 Parameters for the PN/PN Coupler

Parameter	Range of values	Default setting
Voltage check PS1	deactivated / activated	deactivated
Voltage check PS2	deactivated / activated	deactivated
Data validity display DIA	deactivated / activated	deactivated
Diagnostics for data validity	deactivated / activated	activated
Diagnostics for error in other network	deactivated/activated	activated
Diagnostics for difference in network configuration	deactivated/activated	activated

You can assign the parameters separately for the two sides of the PN/PN Coupler.

STEP 7 generates interrupts (e.g. when monitoring a power supply) separately for each side.

Voltage check PS1 / PS2

If you have enabled the voltage check PS1 / PS2, the PN/PN Coupler diagnoses the failure of the power supply on the two bus sides independent of one another. Only activate the voltage check if the corresponding power supply is actually connected.

Data validity display DIA

You use the data validity display DIA to determine whether or not the IO controller connected via the PN/PN Coupler still supplies valid data from the "other" subnet.

Only activate the data validity display DIA if you have configured inputs on the relevant side of the PN/PN Coupler. Modules for the data record transfer are not taken into consideration for this.

The validity of the data is always displayed in bit 0 of the least significant input byte of the PN/PN Coupler: The least significant input byte is the lowest slot number of the first input module.

Bit 0 = 1: received data are valid.

Bit 0 = 0: received data are invalid.

Possible causes:

- An interface of the PN/PN Coupler is faulty
- The PN/PN Coupler in the other subnet has failed
- The PN/PN Coupler in the other subnet is in STOP state.

CAUTION

Incorrect program interpretation

If you have activated the "Data validity display DIA", you must not use the first bit of the first configured input byte for input data or the associated first bit of the first configured output byte in the other subnet for output data!

Diagnostics for data validity

You use the diagnostics for data validity to determine if the IO controller of the other subnet is in STOP state. The online diagnostics indicates "Data invalid" for the respective slot.

This diagnostic message is selected by default and can be disabled for each interface separately.

Diagnostics for error in other network

You use the diagnostics for error in other network to determine that the other bus side has no configuration data.

This diagnostic message is selected by default and can be disabled for each interface separately.

Diagnostics for difference in network configuration

With the diagnostics for difference in network configuration, the PN/PN Coupler outputs a diagnostics interrupt indicating an invalid mapping for the two bus sites.

This diagnostic message is selected by default and can be disabled for each interface separately.

Reference

You can find additional information in section "Diagnostics for Shared Device".

5.7 Commissioning the PN/PN coupler

Requirements

The following requirements must be met before commissioning the PN/PN Coupler:

- You have completely configured and connected the PN/PN Coupler as described in sections Assembling (Page 23) and Connecting (Page 27).
- You have completely set up both PROFINET IO subnets. PROFINET IO is ready for operation.
- You have configured the PN/PN Coupler.
- You have assigned the PN/PN Coupler parameters.

Commissioning the PN/PN Coupler

1. Switch on the power supply for the PN/PN Coupler.
2. Assign a device name to the PN/PN Coupler for each subnet.
3. Download the configuration to the target system.

5.8 Identification data

Definition

Identification data is data that is stored in a module that supports you in:

- Checking the system configuration
- Locating hardware changes in a system
- Troubleshooting in a system

You can unambiguously identify and localize modules online with the identification data.

In STEP 7 TIA Portal, the identification data is displayed on the "Module status - PN/PN Coupler" and "Properties - PN/PN Coupler" tabs (see STEP 7 online help).

Reading the identification data

Each of the two bus sides of the PN/PN Coupler has its own memory area for identification data. You can enter and read out the identification data separately for each of the two bus sides (except I&M0).

You selectively access certain identification data using **Read data record**. Under the associated data record index you obtain the corresponding part of the identification data.

The data records are structured according to the following principle:

Table 5- 4 Basic structure of data records with identification data

Content	Length (bytes)	Coding (hex)
Header information		
BlockType	2	I&M0: 0020 I&M1: 0021 I&M2: 0022 I&M3: 0023
BlockLength	2	I&M0: 0038 I&M1: 0038 I&M2: 0012 I&M3: 0038
BlockVersionHigh	1	01
BlockVersionLow	1	00
Identification data		
Identification data (see table below)	I&M0: 54 I&M1: 54 I&M2: 16 I&M3: 54	

5.8 Identification data

The data structures in the data records correspond to the specifications of PROFINET IO.

Table 5- 5 Identification data

Identification data	Access	Default setting	Explanation
Identification data 0: (data record index AFF0 hex)			
VendorIDHigh	Read (1 byte)	00 hex	Name of the manufacturer: 42 dec = SIEMENS AG
VendorIDLow	Read (1 byte)	2A hex	
Order_ID	Read (20 bytes)	6ES7158-3AD10-0XA0	Article number of the module
IM_SERIAL_NUMBER	Read (16 bytes)		Serial number (device-specific)
IM_HARDWARE_REVISION	Read (2 bytes)	1	Corresponding Hardware version
IM_SOFTWARE_REVISION	Read	Firmware version	Firmware version of the module
• SWRevisionPrefix	(1 byte)	V, R, P, U, T	
• IM_SWRevision_Functional_Enhancement	(1 byte)	01 - FF hex	
• IM_SWRevision_Bug_Fix	(1 byte)	00 - FF hex	
• IM_SWRevision_Internal_Change	(1 byte)	00 - FF hex	
IM_REVISION_COUNTER	Read (2 bytes)	-	Configured changes on the module
IM_PROFILE_ID	Read (2 bytes)	0000	Generic Device
IM_PROFILE_SPECIFIC_TYPE	Read (2 bytes)	0005 hex	On interface modules
IM_VERSION	Read	0101 hex	Version of the identification data (0101 hex = Version 1.1)
• IM_Version_Major	(1 byte)		
• IM_Version_Minor	(1 byte)		
IM_SUPPORTED	Read (2 bytes)	000E hex	Available identification data (I&M1 to I&M3)
Maintenance data 1: (data record index AFF1 hex)			
IM_TAG_FUNCTION	Read/write (32 bytes)	-	Enter an identifier for the module here, that is unique system-wide.
IM_TAG_LOCATION	Read/write (22 bytes)	-	Enter the installation location of the module here.
Maintenance data 2: (data record index AFF2 hex)			
IM_DATE	Read/write (16 bytes)	YYYY-MM-DD HH:MM	Enter the installation date of the module here.
Maintenance data 3: (data record index AFF3 hex)			
IM_DESCRIPTOR	Read/write (54 bytes)	-	Enter a comment about the module here.

Functions

6.1 Data record transfer from one IO controller to another IO controller

6.1.1 Principle of operation

Introduction

The data record transfer via the PN/PN Coupler starting from article number 6ES7158-3AD10-0XA0 enables you to transfer up to 4096 bytes of data per slot acyclically from one IO controller (sender) to another IO controller (receiver).

This acyclic data record transfer enables you to exceed the cyclic I/O data transfer of 1440 bytes of inputs and 1440 bytes of outputs (in total).

The PN/PN Coupler can buffer a maximum of 8 data records per slot with the Storage module type, i.e. provide for reading. The buffer memory operates according to the first in, first out (FIFO) principle. The Publisher module type does not buffer data records. A current data record is always updated.

The maximum number of inputs and outputs cannot be guaranteed for all available send clock settings, depending on the installation used and its configuration. The configured inputs/outputs are checked by the engineering system for the specific setup.

Note

Docking system

Do not use the PN/PN Coupler as a docking station. The use as a docking unit (function: IO devices changing during operation) in a docking system is supported.

Principle of operation

The **Storage** and **Publisher** module types are available for transferring data records. The following figure shows the sequence of the transfer of a data record from one IO controller to another:

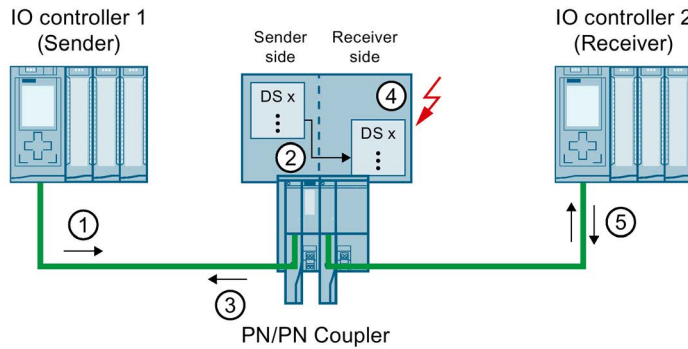

- ① IO controller 1 (sender) issues a send request to the PN/PN Coupler and transfers the data record to the PN/PN Coupler.
- ② The PN/PN Coupler transfers the data record from its sender side to its receiver side.
- ③ The PN/PN Coupler sends an acknowledgment to IO controller 1 that the data record was received.
- ④ The PN/PN Coupler indicates on its receiver side that a data record is available for reading (via status information of the PN/PN Coupler and optionally via an update interrupt in IO controller 2 (receiver)).
- ⑤ Only module type Storage: IO controller 2 (receiver) reads the status information and the data record and acknowledges the receipt.

Figure 6-1 Sequence of the data record transfer

6.1 Data record transfer from one IO controller to another IO controller

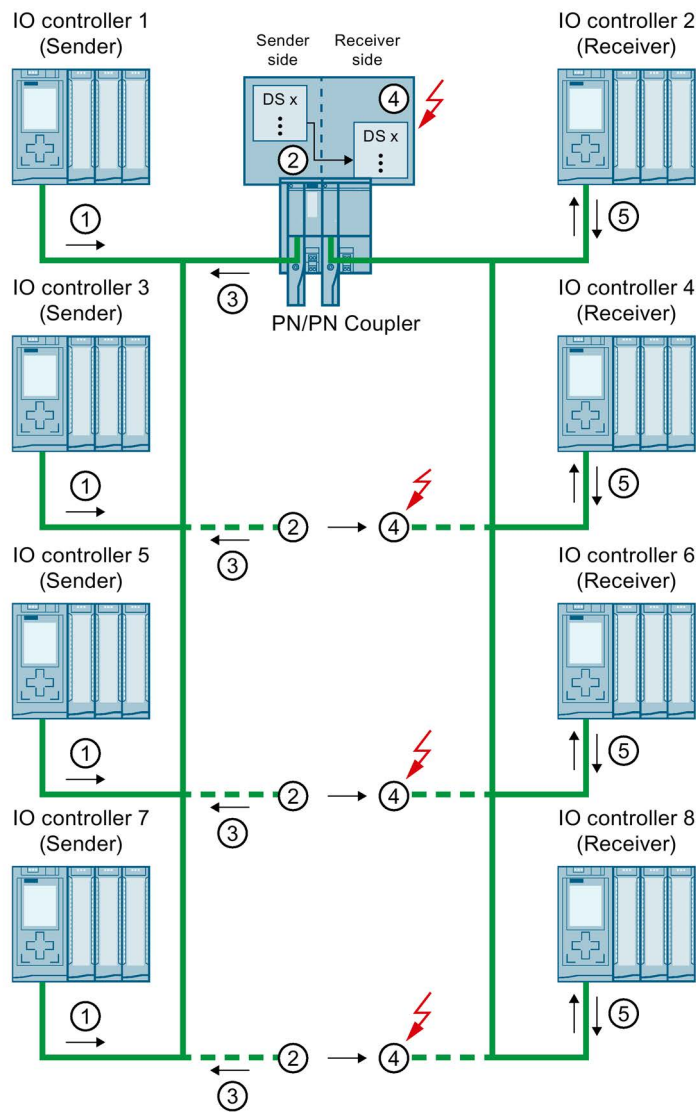

- ① IO controller 1 (sender) issues a send request to the PN/PN Coupler and transfers the data record to the PN/PN Coupler.
- ② The PN/PN Coupler transfers the data record from its sender side to its receiver side.
- ③ The PN/PN Coupler sends an acknowledgment to IO controller 1 that the data record was received.
- ④ The PN/PN Coupler indicates on its receiver side that a data record is available for reading (via status information of the PN/PN Coupler and optionally via an update interrupt in IO controller 2 (receiver)).
- ⑤ Only module type Storage: IO controller 2 (receiver) reads the status information and the data record and acknowledges the receipt.

Figure 6-2 Data transfer from IO controller to IO controller

Boundary conditions for data record transfer

- Data record transfer does not correspond to data record routing.
- The I/O data (status information) are not coupled as a mirror image.
- The data records are transferred in one direction, from the sender to the receiver.
- Both sides of the PN/PN Coupler must be exchanging data with the connected IO controllers. If one side is not exchanging data and data for reading has already been provided, this data is deleted when the side starts exchanging data. The data record transfer starts, if both sides are exchanging data with the IO controllers, from a defined status.

Data record transfer with the Storage module type

- The Storage module type can buffer a maximum of 8 data records per slot, i.e. provide for reading. The buffer memory operates according to the first in, first out (FIFO) principle.
- If the receiver has successfully read a data record, it must explicitly acknowledge this so that this data record is deleted from the buffer memory of the PN/PN Coupler, thereby allowing the next data record to be read.
- If a sender attempts to write a data record to the PN/PN Coupler even though its buffer memory is full, the data record will be rejected by the PN/PN Coupler.

Data record transfer with the Publisher module type

- The Publisher module type does not buffer data records.
- The sender writes only data records with the same "Record Index". This "Record_Index" is set as a parameter of the module on the sender side.
- If the sender delivers the next data record, the previous data record is overwritten.
- The PN/PN Coupler indicates the existence of a new data record using a circulating counter on the receiver side.
- The receiver can read a data record as often as desired.
- If the receiver does not know the length of the data record, you must request the maximum possible length of 4096 bytes in the read request to ensure that the entire data record is read.

Configuring for the data record transfer

For the data record transfer, you configure a virtual module on both sides of the PN/PN Coupler (X1 and X2).

- Module type **Storage**: "RD WRITE STO" on the sender side and "RD READ STO" on the receiver side.
- Module type **Publisher**: "RD WRITE PUB" on the sender side and "RD READ PUB" on the receiver side.

Maximum number of sender and receiver modules

You can configure a maximum of 16 modules "RD WRITE STO", "RD READ STO", "RD WRITE PUB" and "RD READ PUB" per PN/PN Coupler interface (max. data record length of 4096 bytes).

6.1.2 Structure and meaning of status information for the data record transfer

Structure and meaning of status information for the data record transfer in the PN/PN Coupler

Table 6- 1 Status information for the data record transfer - Storage module type

Assigned I/O areas	Description	Function
Sender module RD WRITE STO		
IB x	provider_status	Bit 0 = 1 Communication with the other bus side is established and module "RD READSTO" has been configured on the other bus side. Bit 1 = 1 Query the "level_counter": Maximum value of 8 data records was not reached. Bit 7 = 1 Enable of the data record transfer in the PN/PN Coupler (= group enable; combines information from bit 0 and bit 1).
IB x+1	level_counter	Indicates the fill level of the buffer (maximum of 8 data records)
Receiver module RD READ STO		
IW x	record_index	Display of the data record number of the data record that can be read on the receiver side.
IW x+2	record_length	Length of the data record that can be read on the receiver side.
IB x+4	cycle_counter	Each change in the value (incremental) means that a new data record can be read on the receiver side.
QB x	ack_counter	An acknowledgment for the reading of the data record by the receiver is made by writing the ack_counter output with the value of the cycle_counter input. The data record is then deleted from the buffer.

Note

Writing data records with RD WRITE STO

You can write data records with a data record number in the value range from 2 to 0x7FFF.

Structure and meaning of status information for the data record transfer in the PN/PN Coupler

Table 6- 2 Status information for the data record transfer - Publisher module type

Assigned I/O areas	Description	Function
Sender module RD WRITE PUB		
IB x	provider_status	Bit 0 = 1 Communication with other bus side is established and module "RD READ PUB" has been configured on the other bus side.
Receiver module RD READ PUB		
IW x	record_index	Display of the data record number of the data record that can be read on the receiver side.
EB x+2	cycle_counter	Each change in the value (incremental) means that a new data record can be read on the receiver side.

Note

Writing data records with RD WRITE PUB

You can only write data records with the data record number specified as a parameter in advance in the hardware configuration. Setting range: 2 (default setting) to 0x7FFF.

Update interrupt (OB 56)

You can optionally enable an update interrupt in the parameter assignment of the "RD READ STO" or "RD READ PUB" module that signals the receiver that a new data record is ready for reading in the buffer of the PN/PN Coupler. The update interrupt is disabled by default. A new update interrupt can only be issued when the preceding interrupt has been acknowledged in the user program.

Note

For the Publisher module type, the sender can overwrite the previous data record as often as desired. As a result, it is not guaranteed that the receiver receives an update interrupt for each new data record.

The update interrupt has interrupt type 6. The update interrupt uses the optional structure element AlarmItem, which consists of:

- UserStructureIdentifier: 0x0050 (Unsigned16, manufacturer-specific),
- Data (for identification of the provided data record):
 - RecordIndex (Unsigned16)
 - RecordDataLength (Unsigned32) - for module type **Storage**
 - Reserved (Unsigned32) - for module type **Publisher**

6.2 PROFINET IO functions

6.2.1 Device replacement

Device replacement without topology configuration

The device name is also stored on the BusAdapter in addition to the PN/PN Coupler. A device name stored in the BusAdapter is required for device replacement without topology configuration.

Storing the name on the BusAdapter and the PN/PN Coupler produces a range of scenarios for using the device name when the PN/PN Coupler is replaced.

Table 6- 3 Scenarios for using the device name

	PN/PN Coupler without a device name	PN/PN Coupler with a device name
BusAdapter without a device name	No device name available	The device name from the PN/PN Coupler is used and copied to the BusAdapter.
BusAdapter with device name	The device name from the BusAdapter is used and copied to the PN/PN Coupler.	The device name from the BusAdapter is used and copied to the PN/PN Coupler if the device names are different

Note the following constraints:

- Resetting to factory settings deletes the device name in both the PN/PN Coupler and the BusAdapter. To prevent the device name from being deleted in the BusAdapter, you can remove the BusAdapter from the PN/PN Coupler before resetting to factory settings.
- When a BusAdapter is replaced, a device name stored in the BusAdapter is applied in the PN/PN Coupler after a POWER ON.
- Removal/insertion of the BusAdapter under voltage is not permitted. If you nevertheless remove or insert the BusAdapter under voltage, the PN/PN Coupler restarts.

Device replacement with topology configuration

IO devices with this function can be replaced in a simple manner. The device name does not have to be assigned with the PG/PC.

The replacement IO device is assigned the device name by the IO controller and not by the PG/PC. The IO controller uses the configured topology and the neighborhood relationships determined by the IO devices for this purpose. All involved devices must support the LLDP protocol (Link Layer Discovery Protocol). The configured topology must match the actual topology.

IO devices that were already used in another configuration must be reset to factory settings before being reused.

You can find more information:

- In the STEP 7 online help
- For STEP 7 V14 and higher, in function manual PROFINET with STEP 7 V14 (<http://support.automation.siemens.com/WWW/view/en/49948856>).

6.2.2 Isochronous real-time communication

Isochronous real-time communication

Synchronized transmission method for the cyclic exchange of IRT data between PROFINET devices. A reserved bandwidth within the send clock is available for IRT data. The reserved bandwidth ensures that the IRT data can be transmitted in time-synchronized intervals, unaffected by other high network loading (e.g. TCP/IP communication or additional real time communication).

A topology configuration is required for IRT.

Note

IO controller as sync master with IRT communication

Operation of the IO controller as a sync master is recommended when configuring the IRT communication.

Otherwise, IO devices with IRT and RT configuration could fail as a result of sync master failure.

You can find more information on configuring synchronized PROFINET devices in sync domains:

- In the STEP 7 online help
- For STEP 7 V14 and higher, in function manual PROFINET with STEP 7 V14 (<http://support.automation.siemens.com/WW/view/en/49948856>)

6.2.3 Prioritized startup

Prioritized startup

Prioritized startup is the PROFINET IO functionality for accelerating the startup of IO devices in a PROFINET IO system with IRT and RT communication.

The function reduces the time needed for correspondingly configured IO devices to return to cyclic user data exchange in the following cases:

- After recovery of supply voltage
- After station recovery
- After activation of IO devices

Note

Dependency of the startup time

The PN/PN Coupler enables startup times starting from 750 ms.

You can find more information:

- in the online help for STEP 7 and
- For STEP 7 V14 and higher, in function manual PROFINET with STEP 7 V14 (<http://support.automation.siemens.com/WW/view/en/49948856>).

Note**Prioritized startup and media redundancy**

It is not possible to include an IO device with prioritized startup in a ring topology with media redundancy.

6.2.4 Media redundancy (MRP)

Media redundancy (MRP)

Function for safeguarding communication and system availability. A ring topology ensures that an alternative communication path is made available if a transmission route fails.

You can find more information:

- In the STEP 7 online help
- For STEP 7 V14 and higher, in function manual PROFINET with STEP 7 V14 (<http://support.automation.siemens.com/WW/view/en/49948856>).

Note**Prioritized startup and media redundancy**

It is not possible to include an IO device with prioritized startup in a ring topology with media redundancy.

6.2.5 Shared Device

Shared Device

IO device that makes its data available to up to four IO controllers.

The PN/PN Coupler supports Shared Device at the submodule level.

If the **engineering system does not perform a plausibility check of shared device projects**, note the following:

- Ensure the consistency of the configurations. In particular, each module or submodule may only be assigned to one IO controller. Multiple assignment will result in an error. The module or submodule will only be available in the first IO controller.
- If you reconfigure Shared Device configurations without the validity check mentioned above, you must commission the PN/PN Coupler again. This means you must download the projects of all involved IO controllers to the respective CPU again after reconfiguration and, if necessary, perform a POWER OFF/POWER ON of the PN/PN Coupler.

You can find more information:

- In the STEP 7 online help
- For STEP 7 V14 and higher, in function manual PROFINET with STEP 7 V14 (<http://support.automation.siemens.com/WW/view/en/49948856>)

Note

For a Shared Device application, ensure that all IO controllers work with the same send clock. If IO controllers do not have the same send clock, the different send clock can result in communication relationships not being set up.

If you set up all IO controllers in one project, the same send clock is ensured. Set the same send clock when engineering in separate projects.

Module-internal Shared Input/Shared Output (MSI/MSO)

The module-internal Shared Input function enables an input module to make its input data available to up to four IO controllers. Each IO controller has read access to the same channels.

The module-internal Shared Output function enables an output module to be operated by up to four IO controllers. One IO controller has write access. Up to three additional IO controllers can have read access to the same channels.

You can find more information:

- In the STEP 7 online help
- For STEP 7 V14 and higher, in function manual PROFINET with STEP 7 V14 (<http://support.automation.siemens.com/WW/view/en/49948856>)

PN/PN Coupler as a shared device

When configuring the PN/PN Coupler as a Shared Device, the following conditions apply:

- You can assign a slot to only one IO controller (no Shared Input).
- Slots of one IO device must be assigned one-to-one to the other IO device (couple partner) (e.g. slot 3 on left bus side = slot 3 on right bus side).
- The slots of an IO device can be assigned to an IO controller as desired. An associated slot area is not required.
- You can configure up to four IO controllers on both bus sides.

Example of communication relationship for a shared device

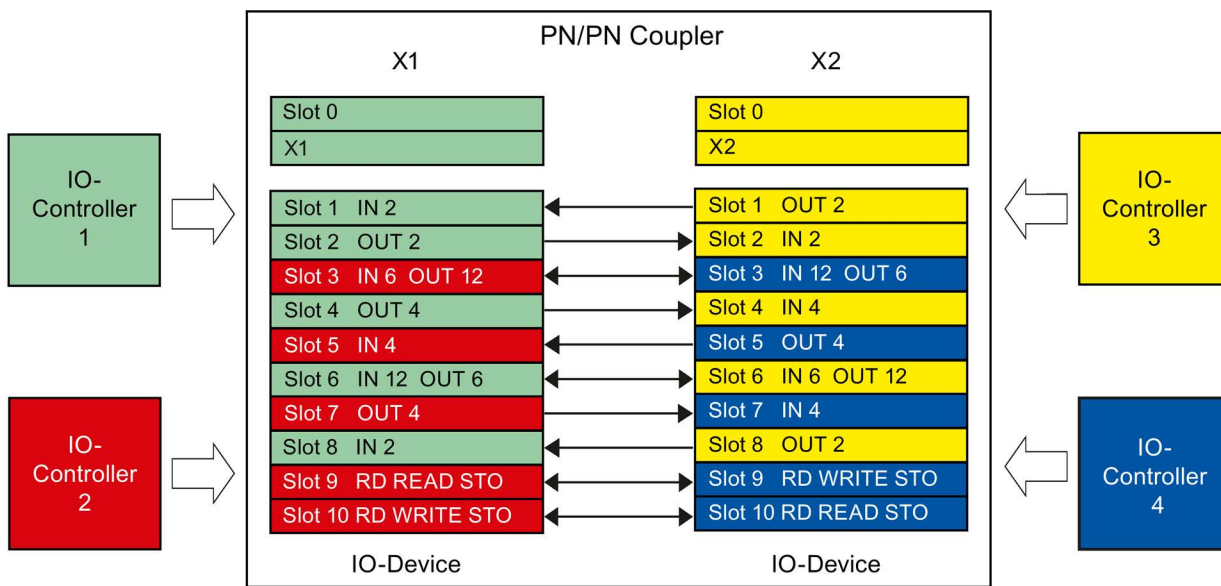

Figure 6-3 Example of communication relationship for a shared device

Example of asymmetric communication relationship for a shared device

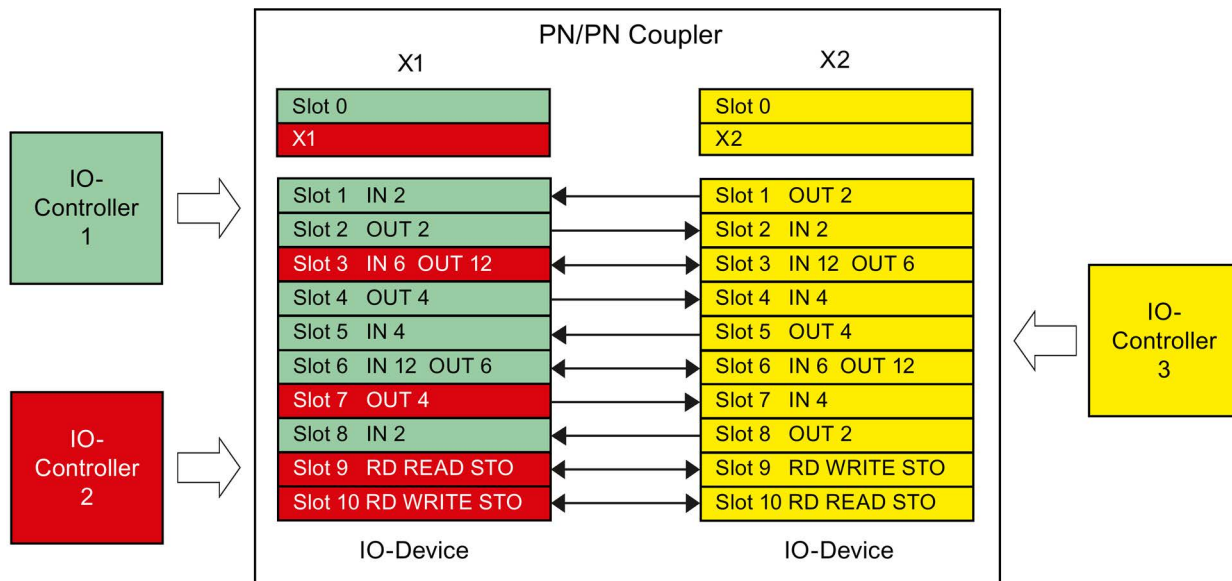

Figure 6-4 Example of asymmetric communication relationship for a shared device

Further information

You can find more information on this topic in the STEP 7 online help.

You can find additional examples in the sections Shared Input/Shared Output as communication functions (Page 79).

6.2.6 Media Redundancy with Planned Duplication (MRPD)

Media Redundancy with Planned Duplication (MRPD)

If your goal is to have media redundancy and short update times (together with IRT), use "Media Redundancy with Planned Duplication (MRPD)".

You can find more information

- In the STEP 7 online help
- For STEP 7 V14 and higher, in function manual PROFINET with STEP 7 V14 (<http://support.automation.siemens.com/WW/view/en/49948856>)

6.3 Shared Input/Shared Output as communication functions

6.3.1 Interface local distribution of IO data

Module-internal Shared Output is transferred to other controllers

In this example, IO data are transferred from one controller to other controllers over the PROFINET interface X1 by means of the Module-internal Shared Output.

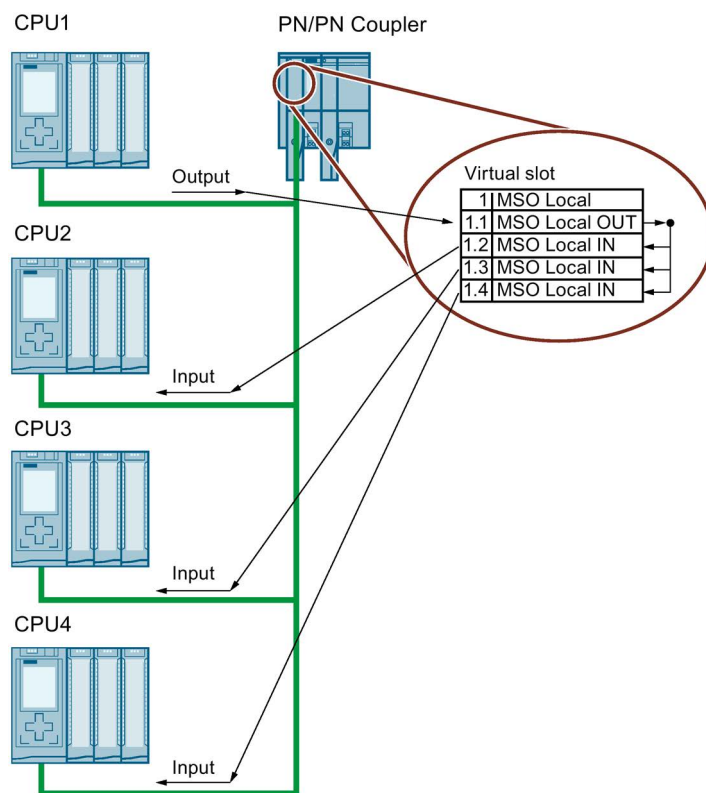

Figure 6-5 IO data are transferred to other controllers on bus side X1

Configuration

Table 6- 4 Configuration for the PROFINET interface X1

PROFINET interface (X1)				
Virtual slot	Type	I-length	Q-length	Access
1	MSO Local	-	-	-
1.1	MSO Local OUT	-	4 bytes	CPU 1
1.2	MSO Local IN	5 bytes incl. 1 byte DS	-	CPU 2
1.3	MSO Local IN	5 bytes incl. 1 byte DS	-	CPU 3
1.4	MSO Local IN	5 bytes incl. 1 byte DS	-	CPU 4

No configuration is required for network side 2.

Editing in the user program

CPU 1 writes IO data to the MSO Local OUT module with the virtual slot 1.1 of the PN/PN Coupler. The data is available to CPUs 2 to 4 for reading with the remaining MSO Local IN modules. The PN/PN Coupler operates CPUs 1 to 4 only over one network side. The validity of the provided user data is displayed by the data status byte (DS) of the MSO Local IN modules.

Side X2 of the PN/PN Coupler is not used.

You can also use this example:

- with fewer controllers and
- configure it with other virtual modules.

6.3.2 Coupling across the network and interface local distribution of IO data

Module-internal Shared Output modules are sent and transferred

In this example, IO data are sent using Module-internal Shared Output

- to the PROFINET interface X2 and sent to a controller and
- other controllers of the same PROFINET interface can only receive IO data if a coupling relationship has been established over the virtual slot with subplot 1 to the partner interface.

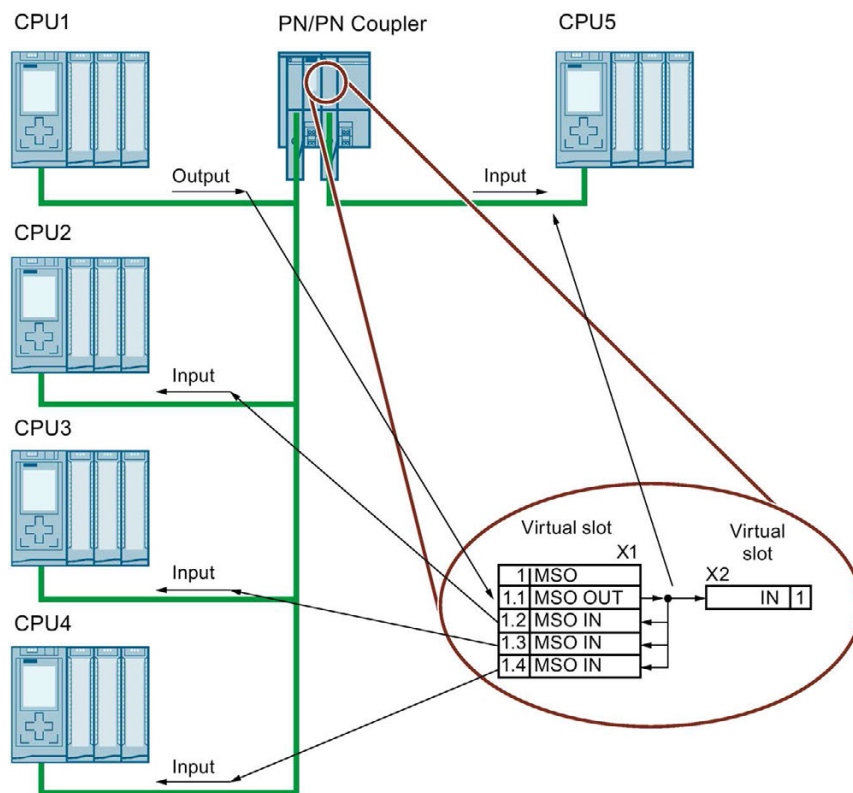

Figure 6-6 IO data are sent to the X2 side and transferred to the X1 side.

Configuration

Table 6- 5 Configuration for the PROFINET interface X1

PROFINET interface (X1)				
Virtual slot	Type	I-length	Q-length	Access
1	MSO	-	-	-
1.1	MSO OUT	-	4 bytes	CPU 1
1.2	MSO IN	5 bytes incl. 1 byte DS	-	CPU 2
1.3	MSO IN	5 bytes incl. 1 byte DS	-	CPU 3
1.4	MSO IN	5 bytes incl. 1 byte DS	-	CPU 4

Table 6- 6 Configuration for the PROFINET interface X2

PROFINET interface (X2)				
Virtual slot	Type	I-length	Q-length	Access
1	IN	5 bytes incl. 1 byte DS	-	CPU 5
2	-	-	-	-
3	-	-	-	-
4	-	-	-	-

Editing in the user program

CPU 1 writes IO data to the MSO OUT module with the virtual slot 1.1 of the PN/PN Coupler. The data is available to CPUs 2 to 4 for reading with the remaining MSO IN modules.

The PN/PN Coupler also makes the written IO data of the MSO OUT module of network side X1 available to the network side X2 by means of an IN module of the PLC 5. The validity of the provided user data on the network sides is displayed by the data status byte (DS) of the MSO Local IN and IN modules.

You can also use this example:

- with fewer controllers and
- configure it with other virtual modules.

6.3.3 Coupling across the network and distribution and interface local distribution of IO data

Module-internal Shared Output modules are sent and transferred

In this example, IO data are transferred using Module-internal Shared Output

- from one controller to other controllers to the PROFINET interface X1
- to the PROFINET interface X2 and sent to a controller and
- other controllers of the same PROFINET interface can only receive IO data if a coupling relationship has been established over the virtual slot with subplot 1 to the partner interface.

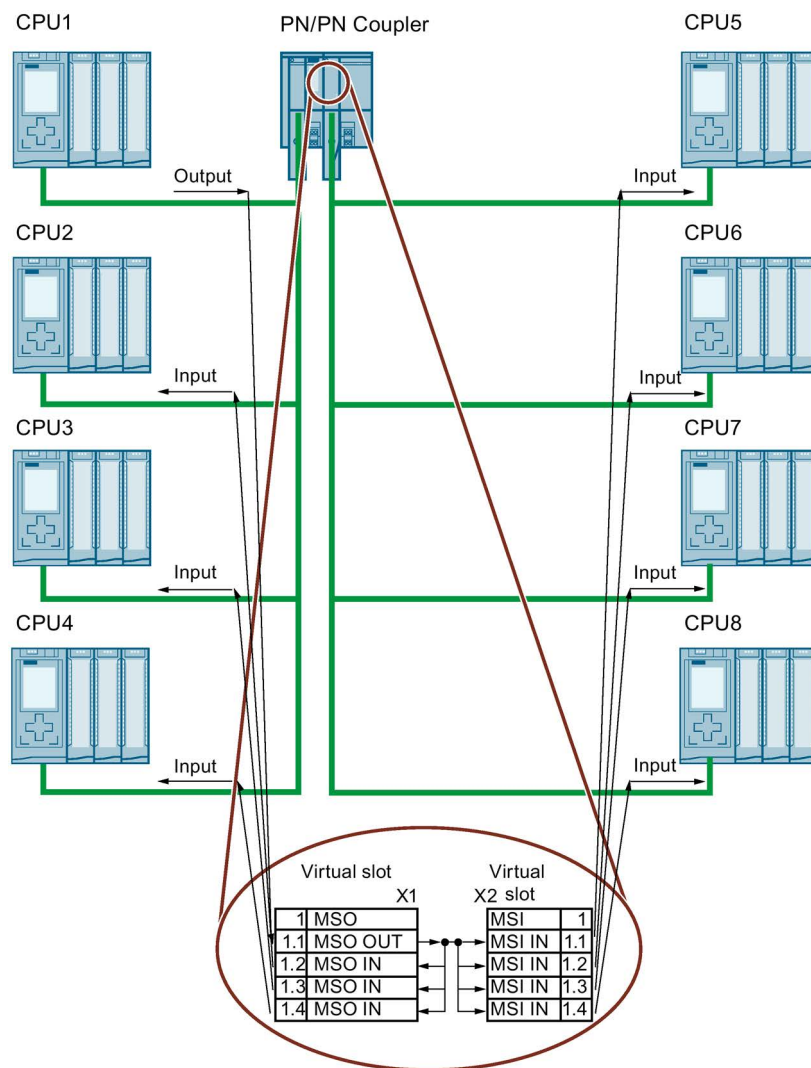

Figure 6-7 IO data are transferred to the X1 side and sent to the X2 side and transferred there

Configuration

Table 6- 7 Configuration for the PROFINET interface X1

PROFINET interface (X1)				
Virtual slot	Type	I-length	Q-length	Access
1	MSO	-	-	-
1.1	MSO OUT	-	4 bytes	CPU 1
1.2	MSO IN	5 bytes incl. 1 byte DS	-	CPU 2
1.3	MSO IN	5 bytes incl. 1 byte DS	-	CPU 3
1.4	MSO IN	5 bytes incl. 1 byte DS	-	CPU 4

Table 6- 8 Configuration for the PROFINET interface X2

PROFINET interface (X2)				
Virtual slot	Type	I-length	Q-length	Access
1	MSI	-	-	-
1.1	MSI IN	5 bytes incl. 1 byte DS	-	CPU 5
1.2	MSI IN	5 bytes incl. 1 byte DS	-	CPU 6
1.3	MSI IN	5 bytes incl. 1 byte DS	-	CPU 7
1.4	MSI IN	5 bytes incl. 1 byte DS	-	CPU 8

Editing in the user program

CPU 1 writes IO data to the MSO OUT module with the virtual slot 1.1 of the PN/PN Coupler. The data is available to CPUs 2 to 4 for reading with the remaining MSO IN modules.

The PN/PN Coupler also makes the written IO data available on the network side X2 to CPUs 5 to 8 through an MSI IN module. The validity of the provided user data on the network sides is displayed by the data status byte (DS) of the MSO OUT and MSI IN modules.

You can also use this example:

- with fewer controllers and
- configure it with other virtual modules.

Note

Data status byte (DS)

In operating mode "IO Modules (ext. comp. V3.x)" the data status byte (DS) is not available. The data validity of the coupled user data is then ensured by the provided user data flags of the PROFINET system.

Interrupts, error messages and diagnostics and system alarms

7

7.1 Diagnostics via LED displays

LEDs on the PN/PN coupler

The LEDs on the PN/PN Coupler and their function are described below.

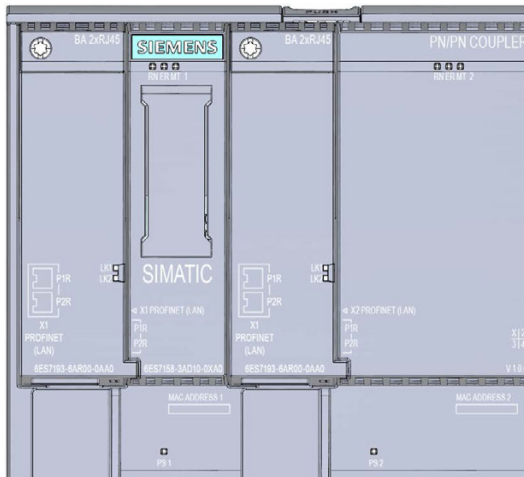

- RN 1 RUN LED PROFINET IO network side 1 (green)
- RN 2 RUN LED PROFINET IO network side 2 (green)
- ER 1 ERROR LED PROFINET IO network side 1 (red)
- ER 2 ERROR LED PROFINET IO network side 2 (red)
- MT 1 Maintenance indicator PROFINET IO network side 1 (yellow)
- MT 2 Maintenance indicator PROFINET IO network side 2 (yellow)
- LK 1 Connection to a switch or IO controller (green) at Port1
- LK 2 Connection to a switch or IO controller (green) at Port2
- PS 1 Power supply PROFINET IO network side 1 (green)
- PS 2 Power supply PROFINET IO network side 2 (green)

Figure 7-1 LEDs on the PN/PN Coupler





Meaning of the LED displays

The following tables contain the meanings of the status and error displays.

RN/ER/MT LEDs on the PN/PN Coupler

Table 7- 1 Status and error displays of RN/ER/MT LEDs

LEDs			Meaning	Remedy
RN 1/2 (RUN)	ER 1/2 (ERROR)	MT 1/2(M AINT)		
□ off	□ off	□ off	Missing or insufficient supply voltage on the PN/PN Coupler.	Check the supply voltage and switch it on at the PN/PN Coupler.
■ on	■ on	■ on	Test of LEDs during startup: The three LEDs light up simultaneously for approximately 0.25 s.	---
			RN/ER/MT LEDs are continuously On and RN/ER/MT LEDs of the other interface are Off or flashing: Hardware or firmware defective. Error information will be determined and stored retentively on the Flash memory.	Do not switch off the PN/PN Coupler as long as X1 LEDs are continuously lit (this process may take a few minutes).
			RN/ER/MT LEDs are continuously On and RN/ER LEDs of the other interface are flashing: Startup was stopped because a BusAdapter that is defective or not supported was detected on the other interface.	Replace the BusAdapter of the other interface.
☀ Flashes	Not relevant	Not relevant	PN/PN Coupler is deactivated.	Activate the PN/PN Coupler with the configuration software or the user program.
			PN/PN Coupler is not configured.	Configure the PN/PN Coupler with the configuration software.
			PN/PN Coupler is starting up.	---
			PN/PN Coupler is being assigned parameters.	---
			PN/PN Coupler is being reset to factory settings.	---
■ on	Not relevant	Not relevant	PN/PN Coupler is currently exchanging data with the IO controller.	---
Not relevant	☀ Flashes	Not relevant	Group errors and group channel faults.	Evaluate the diagnostics and eliminate the error.
			The preset configuration does not match the actual configuration of the PN/PN Coupler .	Check the configuration of the PN/PN Coupler: <ul style="list-style-type: none"> • Whether a module is missing or defective • Whether an unconfigured module is inserted
			Parameter assignment error	Evaluate the display of the module status in STEP 7. Eliminate the error in the corresponding I/O module.
Not relevant	Not relevant	■ on	Maintenance demanded	See section Interrupts (Page 90)

LEDs			Meaning	Remedy
RN 1/2 (RUN)	ER 1/2 (ERROR)	MT 1/2(M AINT)		
 Flashes	 Flashes	 Flashes	The "Node flash test" is running (the LK1 and LK2 LEDs of the PROFINET interface also flash). Hardware or firmware defective (The LK1 and LK2 LEDs of the PROFINET interface do not flash).	--- Restart the device by disconnecting and reconnecting the supply voltage. Run a firmware update. If the error persists, contact Siemens Industry Online Support. Replace the PN/PN Coupler.
 Flashes	 Flashes	Not relevant	Startup was stopped because a BusAdapter that is defective or not supported was detected.	Replace the BusAdapter of this interface.

PS LEDs on the PN/PN Coupler

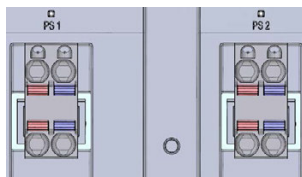



Figure 7-2 PS LEDs on the PN/PN Coupler

Table 7- 2 Status display of the PS LED

PS 1/2 LED	Meaning	Remedy
 off	Missing or insufficient supply voltage	Check the supply voltage.
 on	Supply voltage present	---

LK1/LK2 and MT1/MT2 LEDs on the BusAdapter

Table 7- 3 Status and error displays of LK1/LK2 and MT1/MT2 LEDs

LED		Meaning	Remedy
LK1/LK2	MT1/MT2*		
□ off	Not relevant	There is no Ethernet connection between the PROFINET IO interface of your PROFINET device and a communication partner (e.g. IO controller).	Check whether the bus cable to the switch/IO controller is interrupted.
■ on	Not relevant	There is an Ethernet connection between the PROFINET IO interface of your PROFINET device and a communication partner (e.g. IO controller).	---
⚡ Flashes	Not relevant	The "Node flash test" is running. (The RN/ER/MT LEDs are also flashing.)	---
Not relevant	□ off	No error	---
Not relevant	■ on	<ul style="list-style-type: none"> Fiber-optic error Maintenance demanded: attenuation through the fiber-optic cable is already so high that operation will soon no longer be possible. 	Causes and measures for the transmission route: <ul style="list-style-type: none"> Replacement of fiber-optic cable if damaged or aged Correct installation of the PROFINET connector/PROFINET connections Adherence to maximum length of 50 m for POF cable or 100 m for PCF cable Secure fit of the FOC connector.

* Present only on BA 2×SCRJ,BA SCRJ/RJ45 andBA SCRJ/FC BusAdapters

7.2 Diagnostics by user program

7.2.1 Extended channel diagnostics

Function

The channel diagnostics provides information about channel faults of the PN/PN Coupler.

Channel faults are mapped as channel diagnostics in IO diagnostic data records.

You read the data record with the "RDREC" instruction.

Structure of the diagnostic data records

The data records supported by the PN/PN Coupler are based on the PROFINET IO standard - Application Layer Service Definition V2.3.

If necessary, you can purchase the standard from the PROFIBUS Nutzerorganisation (PROFIBUS user organization (<http://www.profibus.com>)).

Codes of the extended channel diagnostics

The following extended channel diagnostics are signaled for the PN/PN Coupler:

Slot number	ChannelError-Type (CET)	ExtendedChannelError-Type (ECET)	Associated value AddValue	Diagnostics
0	0x0601	0x0681	0x00	Transmitted IO data invalid (partially bad-flagged)
0	0x0602	0x069C	0x00	Invalid BusAdapter on the PN/PN Coupler
0	0x0603	0x06A0	0x00	Error on other network
0	0x0603	0x06A1	Slot	Differences between the two networks at slot n
0	0x0603	0x06A2	0x00	No input data configured for the activated data validity display
0	0x0603	0x06A5	Slot	Shared Device conflict, invalid submodule assignment at slot n
0	0x0610	0x06B3	Number	Power supply error (PS number n)

7.2.2 Interrupts

The IO device initiates interrupts following certain errors. The evaluation of the interrupt is dependent on the IO controller used.

The PN/PN Coupler supports the following interrupts:

- Diagnostics interrupts

If the communication relationship exists between the IO controller and the **PN/PN Coupler**, manufacturer-specific diagnostics of the PN/PN Coupler also become active as interrupts. The interrupts trigger the call of an OB 82 in a SIMATIC CPU.

- Update interrupt (OB 56) for modules "RD READ STO" and "RD READ PUB":

You can optionally enable an update interrupt when configuring the "RD READ STO" and "RD READ PUB" modules: This indicates to the receiver that a new data record is available for reading in the buffer of the PN/PN Coupler.

The update interrupt is disabled by default. A new update interrupt can only be issued when the preceding interrupt has been acknowledged in the user program.

Note

Module "RD READ PUB"

When new data records are received in quick succession, it is not ensured that a separate update interrupt will be issued for each received data record.

- Maintenance alarms

The PN/PN Coupler supports diagnostics and the maintenance concept in PROFINET according to IEC 61158-6-10. The goal is to detect and remove potential problems as early as possible.

For the PN/PN Coupler, maintenance alarms signal to the user when a network component must be checked or replaced.

Maintenance alarms

The PN/PN Coupler signals a maintenance alarm to the higher-level diagnostics system when the following events occur:

Maintenance alarms	Event	Message/Meaning
Maintenance demanded <i>(maintenance demanded)</i> MT LED is lit	Loss of synchronization	<ul style="list-style-type: none"> • No synchronization message frame received After parameterization or during operation, the sync master did not receive a synchronization message frame within the timeout period. <ul style="list-style-type: none"> • Successive synchronization message frames are outside the permissible limits (jitter).
	Critical FOC attenuation	The received light intensity at the FOC port is critical. The FOC should be replaced.

System alarms in STEP 7

The maintenance information is generated in STEP 7 with the following system alarm:

- Maintenance demanded, identified by a yellow wrench icon at the relevant port.

7.2.3 Diagnostics readout

Options for reading out the diagnostic data

You can evaluate manufacturer-specific diagnostics using the corresponding data records (e.g. 0x800B) or using diagnostics interrupts.

Table 7-4 Reading out the diagnostic data with STEP 7.

Automation system with IO controller	Application	See ...
SIMATIC S7	Diagnostics as plain text in STEP 7 in online and diagnostics view	Online help for STEP 7 and as of STEP 7 V 14 PROFINET with STEP 7 V14 http://support.automation.siemens.com/WW/view/en/49948856
	Instruction "RDREC" (SFB 52) Reading data records from the IO device	
	Instruction "RALRM" (SFB 54) Receiving alarms from the IO device	

IO Modules

Based on the DS value in the last byte, the user can recognize the following scenarios:

- 0x40: There is no valid coupling partner of the module input data in the other subnet.
- 0x60: The IO controller in the other subnet is in STOP state.
- 0x80 Valid user data received from coupling partner

Note

Diagnostics

All own module diagnostics can be enabled or disabled.

Structure of the diagnostic data records

You can find the structure of the diagnostic data records and programming examples in the Programming Manual in sections Structure of the diagnostic data records and Examples for the diagnostic data records.

The data records supported by the PN/PN Coupler are based on the PROFINET IO standard - Application Layer Service Definition V2.0.

You can download the standard from the <http://www.profibus.com> (<http://www.profibus.com>) free of charge.

See also

From PROFIBUS DP to PROFINET IO
<http://support.automation.siemens.com/WW/view/en/19289930>

7.2.4 Data validity display

Using the DIA parameter (data validity display), you query information about the validity of the input data supplied from the other bus side of the PN/PN Coupler directly in the user program.

See also

Parameters (Page 62)

7.2.5 Diagnosis in Shared Device

Particularities for diagnostics and data validity:

The following conditions apply to diagnostics and data validity for the PN/PN Coupler as a Shared Device .

- Diagnostics are signaled only to an IO controller that has slot 0.
- The configuration-related diagnostics involve all slots:
 - The diagnosis "Other network side is not configured or has failed" is generated if a partner slot is not available for any individual configured slot.
 - The diagnosis "Different configuration of subnets X1 and X2" is generated if there is a difference in the module ID of the partner slot for at least one slot.
- The diagnosis "Data validity DIA is set, but no input data is configured" covers only the slots that belong to the IO controller that has slot 0.
- Shared Device conflict: invalid submodule assignment at slot n
 - For MSI and MSO modules, submodules of the same length of output and input data must be used.
 - For local MSO modules, the output submodule and at least 1 input submodule must be controlled by the IO controller assigned in each case.

7.2.6 STOP of the IO controller and recovery of the IO device

STOP of IO controller

The PN/PN Coupler indicates the STOP state of the IO controller of the other bus side using the optional "Data validity" diagnostics.

Diagnostics after STOP of the IO controller

If diagnostics are received from the IO device while the IO controller is in STOP state, the corresponding organization blocks are not initiated after startup of the IO controller. You must get an idea of the state of the IO device in OB 100. Evaluate the data status byte (DS) of the input modules in your user program.

Diagnostics after recovery of the IO device

Following recovery of an IO device, you must read data record E00C_H with the "RDREC" instruction. This contains all the diagnostics data for the slots assigned to an IO controller in an IO device.

Operation and maintenance

You update the firmware of the PN/PN Coupler via PROFINET IO:

- In HW Config, or
- In SIMATIC Manager using **PLC > Show accessible devices**
- with the SIMATIC Automation Tool (available on the Internet (<https://support.industry.siemens.com/cs/ww/en/view/98161300>)).

To update the firmware, you will need files (*.UPD) containing the current firmware.

You can find the latest firmware on the Internet (<https://support.industry.com/cs/ww/de/ps/6ES7-3AD10-0XA0/dl>).

8.1 Updating firmware via PROFINET IO

Updating firmware via PROFINET IO

You update the firmware selectively using both PROFINET IO interfaces.

Requirements:

- The PN/PN Coupler must be accessible online for the firmware update.
- The files with the current firmware version must be available in the file system of your programming device or PC.

Note

Firmware activated after download

If you have selected the "Activate firmware after download" option for the firmware update via PROFINET IO, both sides of the coupler will fail temporarily when the firmware is activated.

Further information

The STEP 7 online help system provides information on how to proceed.

8.2 Replacing defective PN/PN coupler

Introduction

For a new PN/PN Coupler, the R/W objects (I&M, SNMP and parameter assignment data) in the PN/PN Coupler are set to factory settings.

Replacement part case

You must bring a previously used PN/PN Coupler to the "Reset to factory settings" state before using it as a replacement part.

Procedure

To replace a defective PN/PN Coupler, follow these steps:

1. De-energize the PN/PN Coupler.
2. Unscrew the BusAdapter.
3. Remove the BusAdapter from the PROFINET IO interfaces of the defective PN/PN Coupler.
4. Remove the power supply of the defective PN/PN Coupler.
5. Replace the defective PN/PN Coupler.
6. Plug the BusAdapters onto the PROFINET IO interfaces of the new PN/PN Coupler and screw them in place.
7. Connect the power supply connection to the new PN/PN Coupler.
8. Switch on the voltage again.

8.3 Reset to factory settings

Requirement

The supply voltage on the PN/PN Coupler is switched on.

Required tools

3 to 3.5 mm screwdriver (for resetting with a RESET button)

Procedure using the RESET button

To reset the PN/PN Coupler to factory settings using the RESET button, follow these steps:

1. Remove the PN/PN Coupler from the mounting rail, see *Disassembling the PN/PN coupler* (Page 25), and swing it downwards.

Note

Power supply must be supplied with voltage

Both power supply connections must be supplied with voltage.

2. The RESET button is located on the back of the PN/PN Coupler behind a small opening: Press a screwdriver into the small opening for at least 3 seconds to activate the RESET button.

Note

One RESET button but two power supplies

When the RESET button is pushed, the power supply must be supplied with voltage on this side of the PN/PN Coupler.

This means if the left side of the PN/PN Coupler is to be reset, only the left power supply must be supplied with voltage and vice versa.

3. Mount the PN/PN Coupler again on the mounting rail, see *Assembling the PN/PN coupler* (Page 24).
4. Reassign the PN/PN Coupler parameters.

For additional information on retentively stored data, refer to the PROFINET Function Manual (<https://support.industry.siemens.com/cs/ww/en/view/49948856>).

Procedure using STEP 7 TIA Portal

To restore the factory settings for the PN/PN Coupler using the STEP 7 TIA Portal, follow these steps:

Ensure there is an online connection to the PN/PN Coupler.

1. Open the list of accessible devices of your PG/PC interface.
2. In the "Functions" folder of any network side of the PN/PN Coupler, select "Reset to factory settings".
3. If you want to keep the I&M data, select the "Retain I&M data" option button. If you want to delete the I&M data, select the "Delete I&M data" option button.
4. Click the "Reset" button.
5. Click "Yes" in response to the confirmation prompt for the process.

Result: The PN/PN Coupler then performs a "Reset to factory settings" for both network sides. All data of the PN/PN Coupler are reset to factory settings. Firmware updates are retained. The included data of the BusAdapters are also deleted.

Technical specifications

9.1 General technical specifications

9.1.1 Introduction

Scope of general technical specifications

The general technical specifications include:

- The standards and test values that are complied with and met by the described components.
- The test criteria based on which the described components were tested.

9.1.2 Standards and approvals

Currently valid markings and approvals

Note**Information on the housing of the PN/PN Coupler**

The currently valid markings and approvals are printed on the housing of the PN/PN Coupler.

5 safety rules for working in and on electrical installations

A set of rules, which are summarized in DIN VDE 0105 as the "five safety rules", are defined for work in or on electrical installations as a preventative measure against electrical accidents:

1. De-energize
2. Secure to prevent reconnection
3. Verify safe isolation from the supply
4. Connect to ground and short-circuit
5. Cover or provide barriers from adjacent live parts

These five safety rules must be applied in the above-indicated order before starting work on electrical equipment. After completing the work, proceed in the reverse order.

It is assumed that every electrician is familiar with these rules.

CE approval



The PN/PN Coupler satisfies the specifications and safety-related requirements of the following EC directives and is in line with the harmonized European standards (EN), which have been published in the Official Journals of the European Community for programmable logic controllers:

- 2014/30/EU "Electromagnetic Compatibility" (EMC Directive)
- 2014/34/EU "Equipment and protective systems intended for use in potentially explosive atmospheres" (Explosion Protection Directive)
- 2011/65/EU "Restriction of the use of certain hazardous substances in electrical and electronic devices" (RoHS Directives).

The EU conformity declaration certificates are available for the responsible authorities and are kept at the following address:

Siemens AG
Digital Factory

Factory Automation
DF FA AS DH AMB
PO Box 1963
D-92209 Amberg, Germany.

They are also available for download on the Siemens Industry Online Support website, under the keyword "Declaration of Conformity".

cULus approval



Underwriters Laboratories Inc. according to

- UL 508 (Industrial Control Equipment)
- CSA C22.2 No. 142 (Process Control Equipment)

OR

cULus HAZ. LOC. approval



Underwriters Laboratories Inc. according to

- UL 508 (Industrial Control Equipment)
- CSA C22.2 No. 142 (Process Control Equipment)
- ANSI/ISA 12.12.01
- CSA C22.2 No. 213 (Hazardous Location)

APPROVED for use in
Class I, Division 2, Group A, B, C, D Tx;
Class I, Zone 2, Group IIC Tx

Installation Instructions for cULus haz.loc.

- WARNING - Explosion Hazard - Do not disconnect while circuit is live unless area is known to be non-hazardous.
- WARNING - Explosion Hazard - Substitution of components may impair suitability for Class I, Division 2 or Zone 2.
- This equipment is suitable for use in Class I, Division 2, Groups A, B, C, D; Class I, Zone 2, Group IIC; or non-hazardous locations.

WARNING: EXPOSURE TO SOME CHEMICALS MAY DEGRADE THE SEALING PROPERTIES OF MATERIALS USED IN THE RELAYS.

OR

FM approval



Factory Mutual Research (FM) according to

- Approval Standard Class Number 3611, 3600, 3810
- ANSI/ISA 82.02.01 (IEC 61010-1)
- CSA C22.2 No. 213
- CSA 22.2 No. 1010.1

APPROVED for use in Class I, Division 2, Group A, B, C, D Tx;
Class I, Zone 2, Group IIC Tx

Installation Instructions for FM

- WARNING - Explosion Hazard - Do not disconnect while circuit is live unless area is known to be non-hazardous.
- WARNING - Explosion Hazard - Substitution of components may impair suitability for Class I, Division 2 or Zone 2.
- This equipment is suitable for use in Class I, Division 2, Groups A, B, C, D; Class I, Zone 2, Group IIC; or non-hazardous locations.

WARNING: EXPOSURE TO SOME CHEMICALS MAY DEGRADE THE SEALING PROPERTIES OF MATERIALS USED IN THE RELAYS.

OR

ATEX approval



In accordance with EN 60079-15 (Electrical apparatus for potentially explosive atmospheres; Type of protection "n") and EN 60079-0 (Electrical apparatus for potentially explosive gas atmospheres - Part 0: General Requirements)



II 3 G Ex nA IIC Tx Gc
DEKRA 12ATEX0038X

OR

IECEX approval



According to IEC 60079-15 (Explosive atmospheres - Part 15: Equipment protection by type of protection "n") and IEC 60079-0 (Explosive atmospheres - Part 0: Equipment - General requirements)



Ex nA IIC Tx Gc
IECEX DEK 13.0010X

RCM (C-Tick) Declaration of conformity for Australia/New Zealand



The PN/PN Coupler fulfills the requirements of the standards:

- AS/NZS 61000.6.4
- IEC 61000-6-4.

Korea Certification



KC registration number: KCC-REM-S49-S71500

Please note that this device corresponds to limit value class A in terms of the emission of radio frequency interference. This device can be used in all areas, except residential areas.

이 기기는 업무용(A급) 전자파 적합기기로서 판매자 또는 사용자는 이 점을 주의하시기 바라며 가정 외의 지역에서 사용하는 것을 목적으로 합니다.

Marking for the Eurasian Customs Union



EAC (Eurasian Conformity)

Customs Union of Russia, Belarus and Kazakhstan

Declaration of conformity with the technical requirements of the Customs Union (TR CU).

IEC 61131

The described components meet the requirements and criteria of IEC 61131-2 standard (Programmable logic controls, part 2: Equipment requirements and tests).

Marine approval

The following marine approvals are planned for the PN/PN Coupler:

Classification organizations:

- ABS (American Bureau of Shipping)
- BV (Bureau Veritas)
- DNV-GL (Det Norske Veritas-Germanischer Lloyd)
- KR (Korean Register of Shipping) and CCS (China Classification Society)
- LRS (Lloyds Register of Shipping)
- Class NK (Nippon Kaiji Kyokai)

WEEE mark (European Union)



Disposal information, observe the local regulations.

PROFINET standard

The described components are based on the IEC 61158-6-10 standard.

Use in industrial environments

The PN/PN Coupler is designed for use in industrial environments. It meets the following standards for this type of use:

- Requirements on interference emission EN 61000-6-4: 2011
- Requirements on immunity EN 61000-6-2: 2005

Use in mixed areas

Under specific prerequisites you can use the PN/PN Coupler in a mixed area. A mixed area is used for residential purposes and for commercial operations that do not significantly impact the residential purpose.

If you want to use the PN/PN Coupler in residential areas, you must ensure that its radio frequency interference emission complies with limit class B in accordance with EN 61000-6-3. Suitable measures for observing these limits for use in a mixed area are, for example:

- Installation of the PN/PN Coupler in grounded control cabinets
- Use of filters in supply lines

An additional individual acceptance test is also required.

Use in residential areas

Note

PN/PN Coupler is not intended for use in residential areas

The PN/PN Coupler is not intended for use in residential areas. If you are using the PN/PN Coupler in residential areas, radio and TV reception may be affected.

Reference

The certificates for the markings and approvals can be found on the Internet under Service&Support (<https://support.industry.siemens.com/>).

9.1.3 Electromagnetic compatibility

Definition

Electromagnetic compatibility (EMC) is the ability of an electrical installation to function satisfactorily in its electromagnetic environment without interfering with that environment.

Among other things, the PN/PN Coupler also meets the requirements of the EMC legislation for the European single market. This requires that the PN/PN Coupler comply with the requirements and guidelines for electrical assembly.

Pulse-shaped interference

The table below shows the electromagnetic compatibility of the described components with regard to pulse-shaped interference. This requires that the system comply with the requirements and guidelines for electrical assembly.

Table 9- 1 Pulse-shaped interference

Pulse-shaped interference	Tested with	Corresponds to severity
Electrostatic discharge in accordance with IEC 61000-4-2	Air discharge: ±8 kV	3
	Contact discharge: ±6 kV	3
Burst pulses (fast transient interference) in accordance with IEC 61000-4-4	±2 kV (power supply cable)	3
	±2 kV (signal cable >30 m)	3
	±1 kV (signal cable <30 m)	
High-energy single pulse (surge) in accordance with IEC 61000-4-5		2
• Symmetric coupling	±0.5 kV (power supply cable)	
• Asymmetric coupling	±1 kV (power supply cable to functional earth FE) ±1 kV (signal cable/data cable to functional earth FE)	

Sinusoidal interference

The following table shows the electromagnetic compatibility of the PN/PN Coupler with regard to sinusoidal interference (HF radiation).

Sinusoidal interference	Test values
HF radiation (electromagnetic fields) according to IEC 61000-4-3	80% amplitude modulation at 1 kHz <ul style="list-style-type: none"> • to 10 V/m from 80 MHz to 1 GHz • to 10 V/m from 1.4 GHz to 2 GHz • to 1 V/m from 2 GHz to 2.7 GHz
HF current feed on cables and cable shields according to IEC 61000-4-6	Test voltage 10 V at 80 % amplitude modulation of 1 kHz in the range from 10 kHz to 80 MHz

Sinusoidal interference

The following table shows the electromagnetic compatibility of the PN/PN Coupler with respect to sinusoidal interference (RF radiation).

Table 9- 2 Sinusoidal interference – RF radiation

RF radiation in accordance with IEC 61000-4-3/NAMUR 21 Electromagnetic RF field, amplitude-modulated		Corresponds with degree of severity
80 to 1000 MHz; 1.4 to 2 GHz	2.0 GHz to 2.7 GHz	3
10 V/m	1 V/m	
80% AM (1 kHz)		

The following table shows the electromagnetic compatibility of the PN/PN Coupler with respect to sinusoidal interference (RF coupling).

Table 9- 3 Sinusoidal disturbance variables – RF coupling

RF coupling in accordance with IEC 61000-4-6	Corresponds with degree of severity
from 10 kHz	3
10 V _{rms}	
80% AM (1 kHz)	
150 Ω source impedance	

Emission of radio interferences

Emission of interference from electromagnetic fields in accordance with EN 55011: limit class A, group 1.

Table 9- 4 Interference emission of electromagnetic fields

Frequency	Interference emission
from 30 to 230 MHz	<40 dB (μV/m) Q
from 230 to 1000 MHz	<47 dB (μV/m) Q
from 1 to 3 GHz	<66 dB (μV/m) P
from 3 to 6 GHz	<70 dB (μV/m) P

Emission of interference via AC supply voltage in accordance with EN 55011: limit class A, group 1.

from 0.15 to 0.5 MHz	< 79 dB (μV)Q < 66 dB (μV)M
from 0.5 to 30 MHz	< 73 dB (μV)Q < 60 dB (μV)M

9.1.4 Transport and storage conditions

Introduction

The described components meet the requirements regarding transport and storage conditions according to IEC 61131-2. The following information applies to modules that are transported and stored in their original packaging.

Transport and storage of modules

Table 9- 5 Transport and storage conditions

Type of condition	Permitted range
Free fall (in shipping package)	≤ 1 m
Temperature	-40 °C to +70 °C
Barometric pressure	1140 hPa to 660 hPa (corresponds to an elevation of -1000 m to 3500 m)
Relative humidity	5% to 95%, without condensation
Sinusoidal vibrations according to IEC 60068-2-6	5 - 8.4 Hz: 3.5 mm 8.4 - 500 Hz: 9.8 m/s ²
Shock according to IEC 60068-2-27	250 m/s ² , 6 ms, 1000 shocks

9.1.5 Mechanical and climatic ambient conditions for operation

Operating conditions

The described components are intended for weather-proof, stationary use.

The device was tested with the following extensions and restrictions in accordance with IEC 60721-3-3 Class 3K3:

Type of condition	Mounting position	Permitted range
Temperature	horizontal	0 ... 60 °C (without condensation)
Temperature	vertical	0 ... 50 °C (without condensation)
Barometric pressure ¹ , altitude	1140 ... 795 hPa, corresponds with an altitude of -1000 to 2000 m	
Relative humidity	From 10% to 90%, no condensation	
Pollutant concentration	SO ₂ : < 0.5 ppm; relative humidity < 60%, no condensation H ₂ S: < 0.1 ppm; relative humidity < 60%, no condensation	

¹ No pressure differential permitted inside and outside of housing/control cabinet

Use with additional measures

Without additional measures the described components must **not** be used in the following locations:

- Locations with a high amount of ionizing radiation
- Locations with difficult operating conditions; e.g. caused by
 - Dust formation
 - Corrosive vapors or gases
 - Strong electrical or magnetic fields
- Equipment that requires special monitoring, e.g.
 - Elevators
 - Electrical equipment in especially hazardous areas

For example, an additional measure can be installation in a cabinet or enclosure.

Mechanical environmental conditions

The following table specifies the mechanical environmental conditions for the described components for sinusoidal vibrations.

Table 9- 6 Mechanical environmental conditions

Frequency range	PN/PN Coupler for operation with a BusAdapter without an RJ45 socket	PN/PN Coupler for operation with a BusAdapter with an RJ45 socket
$5 \leq f \leq 8.4$ Hz	3.5 mm amplitude	
$8.4 \leq f \leq 150$ Hz	1 g constant acceleration	
$10 \leq f \leq 60$ Hz	0.35 mm amplitude	---
$60 \leq f \leq 1000$ Hz	5 g constant acceleration	

Reduction of vibrations

If the described components are exposed to stronger shocks or vibrations, take appropriate measures to reduce the acceleration or the amplitude.

We recommend mounting the described components on damping materials (for example, rubber-metal vibration dampers).

Tests for mechanical environmental conditions

The following table provides information about the type and scope of the tests for environmental mechanical conditions.

Table 9- 7 Tests for mechanical environmental conditions

Test for ...	Test standard	Comment
Vibrations	Vibration test according to IEC 60068-2-6 (sinusoidal)	Type of vibration: Frequency sweeps with a rate of change of 1 octave/minute. BusAdapter with an RJ45 socket <ul style="list-style-type: none"> • 5 Hz ≤ f ≤ 8.4 Hz, 3.5 mm constant amplitude • 8.4 Hz ≤ f ≤ 150 Hz, 1 g constant acceleration BusAdapter without an RJ45 socket <ul style="list-style-type: none"> • 10 Hz ≤ f ≤ 60 Hz, 0.35 mm constant amplitude • 60 Hz ≤ f ≤ 1000 Hz, 5 g constant acceleration Duration of vibration: 10 frequency sweeps per axis in each of three perpendicular axes
Shock	Shock, tested according to IEC 60068-2-27	Type of shock: Half-sine Shock intensity: 150 m/s ² peak value, 11 ms duration Direction of shock: 3 shocks in +/- direction in each of three perpendicular axes
Continuous shock	Shock, tested according to IEC 60068-2-27	Type of shock: Half-sine Shock intensity: 25 g peak value, 6 ms duration Direction of shock: 1000 shocks in +/- direction in each of three perpendicular axes

Climatic environmental conditions

The described components may be used in the following climatic ambient conditions:

Table 9- 8 Climatic environmental conditions

Environmental conditions	Permitted range
Temperature: horizontal installation vertical installation	from 0 to 60 °C (without condensation) from 0 to 50 °C (without condensation)
Relative humidity	from 10% to 90%,
Barometric pressure	1140 to 795 hPa
Pollutant concentration	ISA-S71.04 severity level G1; G2; G3

9.1.6 Specifications for insulation tests, safety class and degree of protection

Isolation

The isolation is designed in accordance with the requirements of EN 61131-2: 2007.

Note

Galvanic isolation with 707 V DC (Type Test) is tested for modules with 24 V DC supply voltage (SELV/PELV).

Pollution degree/overvoltage category according to IEC 61131

- Pollution degree 2
- Overvoltage category: II

Protection class according to IEC 61131-2: 2007

The entire system meets protection class I and includes parts of protection classes II and III. The PN/PN Coupler contains electric circuits of protection class III.

The grounding of the mounting rail must meet the requirements for a functional earth FE.

Recommendation: For an interference-proof setup, the ground conductor should have a cross-section > 6 mm².

To meet the requirements of protection class I, the installation location (e.g. enclosure, control cabinet) must have a protective conductor connection conforming to standards.

Degree of protection IP20

Degree of protection IP20 in accordance with IEC 60529 for the PN/PN Coupler, i.e.:

- Protection against contact with standard test finger
- Protection against foreign objects with diameters greater than 12.5 mm
- No protection against water

9.1.7 Rated voltage

Rated voltage for operation

The components described here work with a rated voltage of 24 V DC. The tolerance range is 19.2 V to 28.8 V.

9.2 Technical specifications of PN/PN Coupler (6ES7158-3AD10-0XA0)

Technical specifications of the PN/PN Coupler

Article number	6ES7158-3AD10-0XA0
Supply voltage	
Rated value (DC)	24 V
permissible range, lower limit (DC)	19.2 V
permissible range, upper limit (DC)	28.8 V
Reverse polarity protection	Yes
Mains buffering	
<ul style="list-style-type: none"> Mains/voltage failure stored energy time 	10 ms
Input current	
Current consumption, max.	360 mA; For 19.2 V input voltage at the right-hand supply terminal, including 2 plugged BA 2x LC
from supply voltage 1L+, max.	320 mA; For 19.2 V input voltage at the left-hand supply terminal, including 2 plugged BA 2x LC
Power loss	
Power loss, typ.	4 W; For 24 V input voltage and 2 plugged BA 2x RJ45 If BusAdapters with an optical interface are plugged, there is an additional 750 mW per optical interface (3 W with 2 plugged BA 2x LC)
Hardware configuration	
Submodules	
<ul style="list-style-type: none"> Number of submodules per station, max. 	116
Protocols	
PROFINET IO Device	
Services	
– Isochronous mode	No
– Open IE communication	Yes
– IRT	Yes
– MRP	Yes
– MRPD	Yes
– PROFINET system redundancy	No
– PROFIenergy	No
– Prioritized startup	Yes
– Shared device	Yes
– Number of IO Controllers with shared device, max.	4; per line side

9.2 Technical specifications of PN/PN Coupler (6ES7158-3AD10-0XA0)

Article number	6ES7158-3AD10-0XA0
Open IE communication	
<ul style="list-style-type: none"> • TCP/IP 	Yes
<ul style="list-style-type: none"> • SNMP 	Yes
<ul style="list-style-type: none"> • LLDP 	Yes
Isochronous mode	
Isochronous operation (application synchronized up to terminal)	No; For operation on isochronous bus
Interrupts/diagnostics/status information	
Diagnostics indication LED	
<ul style="list-style-type: none"> • RUN LED 	Yes; Green LED
<ul style="list-style-type: none"> • ERROR LED 	Yes; Red LED
<ul style="list-style-type: none"> • MAINT LED 	Yes; yellow LED
<ul style="list-style-type: none"> • Monitoring of the supply voltage (PWR-LED) 	Yes; green PWR LED
<ul style="list-style-type: none"> • Connection to network LINK (green) 	Yes; 2x green link LEDs on BusAdapter
Potential separation	
between supply voltage and electronics	Yes; to power input 2
between Ethernet and electronics	Yes
Ambient conditions	
Ambient temperature during operation	
<ul style="list-style-type: none"> • min. 	0 °C
<ul style="list-style-type: none"> • max. 	60 °C; = Tmax for horizontal installation; for vertical installation Tmax = 50 °C
Extended ambient conditions	
<ul style="list-style-type: none"> • relative to ambient temperature-atmospheric pressure-installation altitude 	Up to max. 2 000 m
Dimensions	
Width	100 mm; Minimized with good handling
Height	117 mm
Depth	74 mm; with mounting rail
Weights	
Weight, approx.	200 g; without BusAdapter

Dimension drawing

Dimension drawing

Dimension drawing for PN/PN Coupler (dimensions in mm)

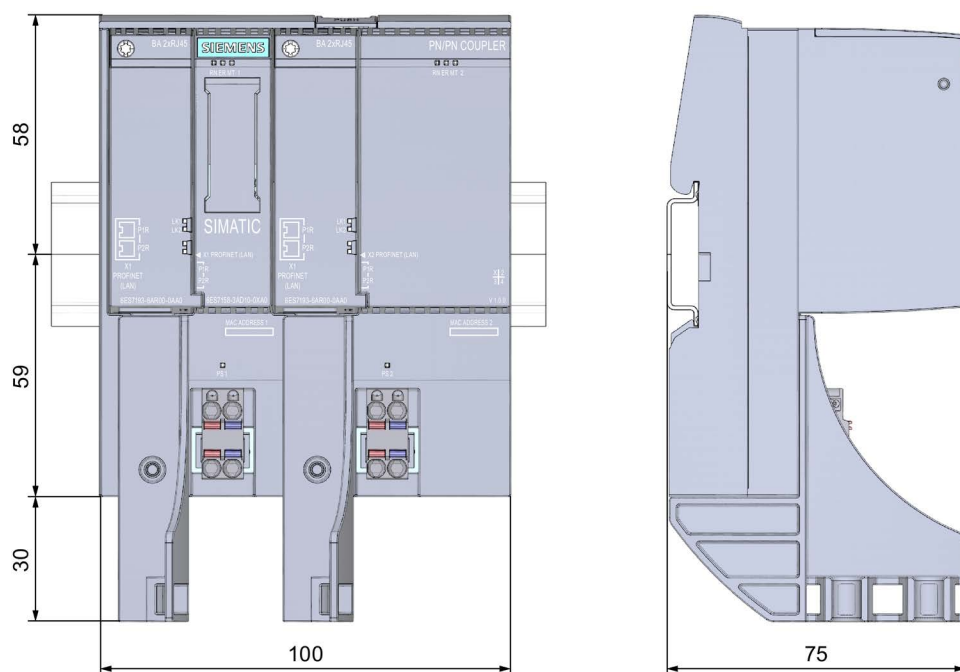

The mounting rail is 7.5 mm deep in the dimension drawing. You can also use a mounting rail with 15 mm.

Article numbers and accessories

Overview

Table B- 1 Article numbers for the PN/PN Coupler

Component	Number in pack	Article number
PN/PN Coupler	1 unit	6ES7158-3AD10-0XA0
BusAdapter		
<ul style="list-style-type: none"> BA 2×RJ45 (PROFINET BusAdapter with standard Ethernet socket) 	1 unit	6ES7193-6AR00-0AA0
<ul style="list-style-type: none"> BA 2×FC (PROFINET BusAdapter with FastConnect Ethernet connection) 	1 unit	6ES7193-6AF00-0AA0
<ul style="list-style-type: none"> BA 2×SCRJ (PROFINET BusAdapter with POF/PCF fiber-optic cable connection) 	1 unit	6ES7193-6AP00-0AA0
<ul style="list-style-type: none"> BA SCRJ/RJ45 (media converter, PROFINET BusAdapter with POF/PCF fiber-optic cable ⇔ standard RJ45 connector) 	1 unit	6ES7193-6AP20-0AA0
<ul style="list-style-type: none"> BA SCRJ/FC (media converter, PROFINET BusAdapter with POF/PCF fiber-optic cable ⇔ direct connection of bus cable) 	1 unit	6ES7193-6AP40-0AA0
<ul style="list-style-type: none"> BA 2xLC (PROFINET BusAdapter with glass fiber-optic cable connection) 	1 unit	6ES7193-6AG00-0AA0
<ul style="list-style-type: none"> BA LC/RJ45 (media converter, PROFINET BusAdapter with glass fiber-optic cable ⇔ standard RJ45 connector) 	1 unit	6ES7193-6AG20-0AA0
<ul style="list-style-type: none"> BA LC/FC (media converter, PROFINET BusAdapter with glass fiber-optic cable ⇔ direct connection of bus cable) 	1 unit	6ES7193-6AG40-0AA0
Cover for the BusAdapter interface	5 units	6ES7591-3AA00-0AA0
24 V DC connector	10 units	6ES7193-4JB00-0AA0
Reference identification label, sheet with 16 labels	10 units	6ES7193-6LF30-0AW0

Component	Number in pack	Article number
Mounting rails, tin-plated steel strip		
• Length: 483 mm	1 unit	6ES5710-8MA11
• Length: 530 mm	1 unit	6ES5710-8MA21
• Length: 830 mm	1 unit	6ES5710-8MA31
• Length: 2000 mm	1 unit	6ES5710-8MA41
Strain relief	5 units	6ES7193-6RA00-1AN0

Response times

Response times

The time that elapses between an IO controller writing to the process image outputs and when this data can be read in the process image of the second IO controller depends on the following:

- CPU cycle time of the two IO controllers
- Bus cycle time of the associated IO controller
- Duration for copying within the PN/PN Coupler (T_{COPY})
- Total data length in bytes (input/output)

The copying duration of the PN/PN Coupler depends on the data transmission rate used. It consists of the copy routine for the inputs and for the outputs. The following maximum values apply:

$$T_{COPY} = 25 \mu s + nIN \times 0.06 \mu s + nOUT \times 0.03 \mu s + (nSUB-1) \times 3.5 \mu s$$

- nIN: Number of bytes of inputs
- nOUT: Number of bytes of outputs
- nSUB: Number of submodules used

Influencing factors for the response times

The following applies to time-critical applications:

- Divide the data among as few modules and submodules as possible.
- Do not use data record modules.
- Exchange as little data as possible via the PN/PN Coupler.
- Do not request diagnostic data from the IO controller.
- Do not activate the data validity display DIA.
- Do not activate the data validity diagnostics.

Compatibility

Replacing PN/PN Coupler \leq V3.0 with PN/PN Coupler \geq V4.0

If you replace PN/PN Coupler \leq V3.0 with PN/PN Coupler \geq V4.0, no reconfiguring or rewiring is necessary, except in the following cases:

- You used a SIMATIC memory card in the project. Because PN/PN Coupler V4.0 and higher no longer has a SIMATIC memory card, the BusAdapter acts as a memory card. In this case, you must provide the PN/PN Coupler with the device name, e.g. with STEP 7 TIA Portal or with PRONETA.
- You have used an angled 90° PROFINET connector and you want to use the following BusAdapters:
 - BusAdapter with RJ45 socket: Replace the angled PROFINET connector with the BusAdapter 2×RJ45 socket (for example with SIMATIC NET IE FC RJ45 Plug 180).
 - BusAdapter with FC connection: Connect the PROFINET cable directly.

Note

New assembly

You do not have to remove the PROFINET cables again for a new assembly.

- The transmission rate of 10 Mbps for Ethernet services is not supported.
- You have configured the IRT operating mode "Flexibility". You now need to re-configure the PN/PN Coupler with the "IRT" operating mode for STEP 7 TIA Portal.
- Manufacturer-specific diagnostics: the User Structure Identifier (USI) is reduced from 4 bytes to 3 bytes.

PN/PN Coupler \geq V4.0 with configuration for firmware version \leq V3.0

If you are using a PN/PN-Coupler as of article number 6ES7 158-3AD10-0XA0 and firmware version V4.0 under configuration of a PN/PN Coupler with FW version \leq V3.0 (compatibility mode), the PN/PN Coupler works in the module operating mode "IO Modules".

The data validity of the coupled user data in this module operating mode is ensured by the provided user data flags of the PROFINET system.

Note

Module operating mode for PN/PN Coupler with firmware version \leq 3.0"

The module operating mode "IO Modules" for the firmware version \leq V3.0 uses the concept of closer data coupling. This means no additional data status byte (DS) is used for the input modules.

Glossary

Autonegotiation

Configuration protocol in Fast Ethernet. Before the actual data transfer, the devices on the network agree on a transfer mode that each participating device can work with (100 Mbps or 10 Mbps, full-duplex or half-duplex).

Bus

A common transfer route connecting all nodes and having two defined ends.

BusAdapter

Enables free selection of the connection technology and layout for the PROFINET fieldbus.

Cross-over cable

A cross-over cable is a four-wire or eight-wire twisted pair cable in which specific cable wires are swapped in one of the two RJ45 connectors. You can use a cross-over cable to connect two controllers directly with each other.

Data record routing

Forwarding of data records beyond subnet boundaries from a sender to receivers via a router.

Data status byte (for inputs only)

Users need the data status byte (DS) to check the validity of the coupled user data. An additional byte is added to all input modules; it can be evaluated in the user program.

Device name

Before an IO Device can be addressed by an IO Controller, it must have a device name. This procedure was selected for PROFINET because names are easier to handle than complex IP addresses.

Assignment of a device name for a specific IO Device can be compared with the setting of the PROFIBUS address for a DP slave.

An IO Device does not have a device name upon delivery. Only once a device name has been assigned using the PG/PC, can an IO Device be addressed by an IO Controller, e.g. for the transmission of configuring data (including the IP address) during start-up or for the exchange of useful data in cyclic mode.

Device replacement without removable medium/programming device

IO Devices having this function can be replaced simply:

- A removable medium (such as Micro Memory Card) with the stored device name is not required.
- The device name does not have to be assigned using the programming device.

The replaced IO Device receives the device name from the IO Controller, not from the removable medium or from the programming device. For this purpose, the IO Controller uses the configured topology and the neighborhood relationships determined by the IO Devices. The configured setpoint topology must agree with the actual topology.

Diagnostics

Diagnostics is the detection, localization, classification, display and further evaluation of errors, faults, and messages.

Diagnostics provides monitoring functions that run automatically while the system is in operation. This increases the availability of systems by reducing setup times and downtimes.

Earth

The conductive earth whose electric potential can be set to zero at any point.

Electromagnetic compatibility (EMC)

Electromagnetic compatibility is understood as the ability of a piece of electrical equipment to function perfectly in a specified environment without impacting on its surroundings in an impermissible way.

Equipment, electrical

All components, power circuits or parts of power circuits that are normally to be found in one single enclosure.

Equipotential bonding

Electrical connection (equipotential bonding conductor) that brings the conductive parts of electrical equipment and other conductive parts to the same or approximately the same potential in order to prevent troublesome or dangerous voltages arising between these parts.

External lightning protection

External plant components at which galvanic coupling of lightning surges is excluded. Corresponds with lightning protection zone 0_A and 0_B.

Fast Ethernet

Fast Ethernet describes the standard for transmitting data at 100 Mbps. This transfer technology uses the 100 Base-T standard for this.

Firmware update

Updating of firmware of interface module

After (compatible) function extensions or after improvements to performance, the interface module can be updated to the latest firmware version.

Ground

The ground refers to all the interconnected inactive parts of a piece of equipment that, even in the event of a fault, cannot pick up voltage that is dangerous to touch.

Grounding

Grounding means connecting an electrically conductive part to a grounding system by means of the ground electrode.

GSD file

The properties of a PROFINET device are described in a GSD file (General Station Descriptor), which contains all the information required for configuration.

As with PROFIBUS, you can link a PROFINET device in STEP 7 by means of a GSD file.

In PROFINET IO, the GSD file is always in XML format. The structure of the GSD file corresponds to ISO 15734, the worldwide standard for device descriptions.

HW Config

Part of STEP 7 for configuring hardware.

Industrial Ethernet

Industrial Ethernet (previously SINEC H1) is a technology that allows data to be transferred without interference in an industrial environment.

Due to the openness of PROFINET, you can use standard Ethernet components. We recommend, however, that you install PROFINET as Industrial Ethernet.

Isochronous real-time communication

Synchronized transmission method for the cyclic exchange of IRT data between PROFINET devices.

A reserved bandwidth is available within the send cycle for IRT IO data. The reserved bandwidth guarantees that IRT data can also be transferred at reserved, synchronized intervals while other, higher network loads are active (for example, TCP/IP communication, or additional real-time communication).

LAN

Local Area Network; interconnects multiple computers within a company. The geographical topology of a LAN is limited to the local premises and is only available to the operating company or institution.

LLDP

LLDP (Link Layer Discovery Protocol) is a protocol that is used to detect the closest neighbors. It enables a device to send information about itself and to save information received from neighboring devices in the LLDP MIB. This information can be looked up via the SNMP. This information allows a network management system to determine the network topology.

MAC address

Each PROFINET device is assigned a worldwide unique device identifier in the factory. This 6-byte long device identifier is the MAC address.

The MAC address consists of:

- 3-byte manufacturer ID and
- 3-byte device ID (sequential number).

The MAC address is placed legibly on the front of the device
e.g.: 08-00-06-6B-80-C0

MDI

In network connections it is normal for each device to be equipped with separate cable wires for transmitting and receiving. The network sockets (MDI) must be coupled in such a way that the transmit wire of one device lines up with the receive wire of the other device. If you use a cross-over cable, the wires are thereby interchanged (crossed) and communication is possible without additional devices.

MDI-X

The MDI-X connection type refers to a socket that is already internally crossed in the device. It is common in distribution devices, such as switches.

Parameter assignment

The term parameterization denotes the transfer of parameters from the IO Controller to the IO Device.

PELV

Protective Extra Low Voltage = extra low voltage with safe isolation that is grounded.

Power supply unit

A power supply unit supplies power to the field devices and the distributed process I/Os connected to them.

Prioritized startup

Prioritized startup denotes PROFINET functionality for accelerating the startup of IO Devices in a PROFINET IO system with RT and IRT communication. The function reduces the time that the correspondingly configured IO Devices require in order to return to the cyclic user data exchange in the following cases:

- After the supply voltage has returned
- After station recovery
- After IO Devices have been activated

Process image

The process image is part of the IO Controller's system memory. The signal states of the input modules are transferred to the process-image inputs at the beginning of the cyclic program. At the end of the cyclic program, the process image of the outputs is transferred to the IO Controller as signal status.

PROFIBUS International

Technical committee dedicated to the definition and development of the PROFIBUS and PROFINET standard.

PROFINET

Within the context of Totally Integrated Automation (TIA), PROFINET is the systematic continuation of the following systems:

- PROFIBUS DP, the established fieldbus
- Industrial Ethernet, the communication bus for the cell level

Experiences from both systems have been and are being integrated in PROFINET.

PROFINET is an Ethernet-based automation standard of PROFIBUS International (previously PROFIBUS User Organization e.V.), and defines a multi-vendor communication, automation, and engineering model. PROFINET has been part of IEC 61158 since 2003.

See PROFIBUS International

PROFINET components

A PROFINET component includes all data of the hardware configuration, the parameters of the modules, and the associated user program. The PROFINET component comprises the following elements:

- Technological function

The (optional) technological (software) function includes the interface to other PROFINET components as interconnectable inputs and outputs.

- Device

The device represents the physical automation device or field device, including the IO, sensors and actuators, mechanical system, and device firmware.

PROFINET device

A PROFINET device always has at least one Industrial Ethernet port. Additionally, a PROFINET device can have a PROFIBUS connection: as master with proxy functions. In exceptions, a PROFINET device can also have a several PROFIBUS connections (for example CP 5614).

PROFINET IO Controller

Device by means of which connected IO Devices are addressed. In other words: The IO Controller exchanges input and output signals with the assigned field devices. The IO Controller is often the controller in which the automation program is executed.

PROFINET IO

Within the context of PROFINET, PROFINET IO is a communication concept for implementing modular, distributed applications.

PROFINET IO allows you to create automation solutions familiar from PROFIBUS.

Implementation of PROFINET IO is carried out on the one hand via the PROFINET standard for automation devices and on the other by using the engineering tool STEP 7.

This means that you have the same application layer in STEP 7 – regardless of whether you configure PROFINET devices or PROFIBUS devices. The programming of your user program is identical for PROFINET IO and PROFIBUS DP when you use the blocks and system status lists expanded for PROFINET IO.

PROFINET IO Device

Distributed field device which is assigned to one of the IO Controllers (e.g. remote IO, valve terminals, frequency converter, switches).

Reference potential

Potential that is used to view and/or measure voltages for each circuit involved.

SELV

Safety extra low voltage (SELV) is voltage ≤ 30 V AC/60 V DC that is generated via a safety transformer or accumulator.

SNMP

SNMP (Simple Network Management Protocol) is the standardized protocol, for diagnosing and also configuring the Ethernet network infrastructure.

In the office setting and in automation engineering, devices from many different manufacturers support SNMP on the Ethernet.

SNMP-based applications can be operated on the same network in parallel to applications with PROFINET.

The scope of the supported functions differs depending on the device type. For example, a switch has more functions than a CP 1616.

Switch

PROFIBUS is a linear network. The communication nodes are connected with one another by means of a passive line - the bus.

By contrast, the Industrial Ethernet consists of point-to-point connections: each communication node is directly connected to exactly one communication node.

If a communication node is connected with several communication nodes, this communication node is connected to the port of an active network component - the switch. Additional communication nodes (including switches) can now be connected to the other ports of the switch. The connection between a communication node and the switch remains a point-to-point connection.

A switch also has the task of regenerating and distributing received signals. The switch "learns" the Ethernet address(es) of a connected PROFINET device or other switches and only forwards signals, which are destined for the connected PROFINET device or the connected switch.

A switch has a specific number of ports. You connect at most one PROFINET device or additional switch to each port.

TN-S system

In a TN-S system, the neutral conductor (N) and protective conductor (PE) are wire with separate insulation. The neutral conductor is connected to the grounded protective conductor at a central point, and only there. The protective conductor can be grounded any number of times.

Transmission rate

The transmission rate specifies the number of bits transmitted per second.

ungrounded

Having no conductive connection to earth

User data flag

Each IO module is assigned a value in the input or output data message; this value provides a statement on the quality of this user datum. For example, outputs of a specific module can be switched off by means of this without affecting other modules.

Index

2

24 V DC power supply, 28

A

Accessories, 20, 113

Approval

CE, 99

Approvals, 98

FM, 100

Area of application, 15

Article number, 18, 113

Assignment of the modules, 56

B

Basic knowledge, 3

BF (LED), 85

Boundary conditions

Data record transfer, 70

BusAdapter, 113

C

Cable, 113

CE approval, 99

Climatic environmental conditions, 108

Commissioning, 64

Compatibility limitations, 116

Components for mounting, 24

Configuration

Overview, 55

Configuring

RD READ PUB, 70

RD READ STO, 70

RD WRITE PUB, 70

RD WRITE STO, 70

with a different configuration tool, 61

with GSD file, 61

with STEP 7 TIA Portal, 58

Configuring with STEP 7 TIA Portal

Example, 59

Connecting

BusAdapter BA 2xFC to the PN/PN Coupler, 35

BusAdapter BA 2xLC to the PN/PN Coupler, 42

BusAdapter BA 2xRJ45 to PN/PN Coupler, 34

BusAdapter BA 2xSCRJ to the PN/PN Coupler, 38

BusAdapter BA 2xSCRJ/FC to the PN/PN Coupler, 40

BusAdapter BA LC/FC to the PN/PN Coupler, 46

BusAdapter BA SCRJ/RJ45 to the PN/PN

Coupler, 41

Connecting BusAdapter BA LC/RJ45 to the interface module, 45

Connecting BusAdapter BA 2xSCRJ, 38

Connecting BusAdapter BA 2xFC, 35

Connecting BusAdapter BA 2xLC, 42

Connecting BusAdapter BA 2xRJ45, 34

Connecting BusAdapter BA 2xSCRJ/FC, 40

Connecting BusAdapter BA LC/FC, 46

Connecting BusAdapter BA LC/RJ45, 45

Connecting BusAdapter BA SCRJ/RJ45, 41

Connections, 29

Customer benefits, 15

D

Data record transfer, 67, (Storage module type)

Configuring, 70

Publisher module type, 72

Degree of protection, 109

Delivery state, 96

Device name

Deleting, 96

Device replacement, 73

Diagnostic data records

Structure, 91

Diagnostics

after IO controller STOP, 93

after recovery of the IO device, 93

Extended channel diagnostics, 89

Options for reading out, 91

Shared Device, 92

Diagnostics interrupt, 90

Dimension drawing, 112

Display elements, 21, 85

Disposal, 3

E

Electrical isolation, 27

Electromagnetic compatibility (EMC), 103
EMC (Electromagnetic compatibility), 103
EMERGENCY STOP equipment, 28
Environmental conditions
 Climatic, 108
 Mechanical, 107, 108
 Operation, 106
 Transport and storage, 105
Equipment
 Open, 23
Error displays, 85
Extended channel diagnostics, 89

F

Factory settings
 Delivery state, 96
 Resetting to, 96
FM approval, 100
Functions
 New, 13

G

Galvanic properties, 27
Grounding, 27
GSD file, 61
 of STEP 7 TIA Portal, 60

I

Identification data, 65
IEC 61131, 101
Installation
 Ungrounded, 27
Installation rules
 Mounting position, 23
Interfaces, 21
Interference
 Pulse-shaped, 103
 sinusoidal, 104
Interrupt
 Diagnostics interrupt, 90
 Update interrupt, 90
IO controller STOP
 Subsequent diagnostics, 93
Isochronous real-time communication, 74
Isolation, 109

L

LEDs, 85
Lightning protection
 24 V DC power supply, 28
LINK (LED), 85

M

Maintenance alarm, 90
Marine approval, 102
Mechanical environmental conditions, 108
Media redundancy, 75
Media Redundancy with Planned Duplication (MRPD), 78
Module
 PROFIsafe, 57
Module replacement, 95
Module type
 Publisher, 70
 Storage, 70
Module-internal Shared Input/Shared Output, 76
Modules
 Assignment, 56
Mounting, 24
Mounting position, 23
Mounting technology, 23

O

OB 56, 72
ON (LED), 85
Operating conditions, 106

P

Parameters, 62
PN/PN Coupler
 Mounting, 24
 Parameter assignment, 62
 Replacing, 95
 Uninstalling, 25
Power supply
 Connecting, 30
 on both sides, 30
Principle of operation, 17
Prior knowledge, 3
Prioritized startup, 74
PROFINET IO
 Cable, 113
 Connecting BusAdapter BA 2×SCRJ, 38

- Connecting BusAdapter BA 2xFC, 35
- Connecting BusAdapter BA 2xLC, 42
- Connecting BusAdapter BA 2xRJ45, 34
- Connecting BusAdapter BA LC/FC, 46
- Connecting BusAdapter BA LC/RJ45, 45
- Connecting BusAdapter BA SCRJ/FC, 40
- Connecting BusAdapter BA SCRJ/RJ45, 41
- Standard, 102
 - with BusAdapter BA 2xFC, 48
 - with BusAdapter BA 2xLC, 50
 - with BusAdapter BA 2xRJ45, 47
 - with BusAdapter BA 2xSCRJ, 48
 - with BusAdapter BA LC/FC, 51
 - with BusAdapter BA LC/RJ45, 50
 - with BusAdapter BA SCRJ/FC, 49
 - with BusAdapter SCRJ/RJ45, 49
- PROFIsafe module, 57
- Properties, 19, 27
 - via PROFINET IO, 20
- Protection class, 109, 109
- Purpose of this manual, 3

R

- Radio interference, 103
- Radio interferences
 - Emission of, 105
- Rated voltage, 109
- Recovery of the IO device
 - Subsequent diagnostics, 93
- Recycling, 3
- Replacement
 - Defective PN/PN Coupler, 95
- Response times, 115
 - Influencing factors, 115
- RX/TX (LED), 85

S

- Safety rules, 98
- Scope, 3
- SF (LED), 85
- Shared Device, 76
 - Diagnostics, 92
- Standard mounting rail, 24, 113
- Standards, 98, 99
- Status and error displays
 - LEDs, 85
- Status displays, 85

T

- Technical specifications
 - Electromagnetic compatibility (EMC), 103
 - PN/PN Coupler, 110
 - Standards and approvals, 98
- Test voltage, 109
- Two-sided power supply, 30

U

- Ungrounded installation, 27
- Uninstalling, 25
- Update interrupt, 72, 90
- Updating firmware, 94
- Use
 - in industrial environments, 102
 - in mixed areas, 102
 - in residential areas, 103

V

- Vibrations, 107
- View, 18