

SIEMENS

SIMATIC HMI

HMI devices

TP1200 Comfort PRO,
TP1500 Comfort PRO,
TP1900 Comfort PRO,
TP2200 Comfort PRO

Compact Operating Instructions

Preface

Overview

1

Safety instructions

2

Mounting and connecting the
HMI device

3

Commissioning the device

4

Maintenance and care

5

Technical information

6



Technical Support

A

Legal information

Warning notice system

This manual contains notices you have to observe in order to ensure your personal safety, as well as to prevent damage to property. The notices referring to your personal safety are highlighted in the manual by a safety alert symbol, notices referring only to property damage have no safety alert symbol. These notices shown below are graded according to the degree of danger.

 DANGER
indicates that death or severe personal injury will result if proper precautions are not taken.
 WARNING
indicates that death or severe personal injury may result if proper precautions are not taken.
 CAUTION
indicates that minor personal injury can result if proper precautions are not taken.
NOTICE
indicates that property damage can result if proper precautions are not taken.

If more than one degree of danger is present, the warning notice representing the highest degree of danger will be used. A notice warning of injury to persons with a safety alert symbol may also include a warning relating to property damage.

Qualified Personnel

The product/system described in this documentation may be operated only by **personnel qualified** for the specific task in accordance with the relevant documentation, in particular its warning notices and safety instructions. Qualified personnel are those who, based on their training and experience, are capable of identifying risks and avoiding potential hazards when working with these products/systems.

Proper use of Siemens products

Note the following:

 WARNING
Siemens products may only be used for the applications described in the catalog and in the relevant technical documentation. If products and components from other manufacturers are used, these must be recommended or approved by Siemens. Proper transport, storage, installation, assembly, commissioning, operation and maintenance are required to ensure that the products operate safely and without any problems. The permissible ambient conditions must be complied with. The information in the relevant documentation must be observed.

Trademarks

All names identified by ® are registered trademarks of Siemens AG. The remaining trademarks in this publication may be trademarks whose use by third parties for their own purposes could violate the rights of the owner.

Disclaimer of Liability

We have reviewed the contents of this publication to ensure consistency with the hardware and software described. Since variance cannot be precluded entirely, we cannot guarantee full consistency. However, the information in this publication is reviewed regularly and any necessary corrections are included in subsequent editions.

Preface

Validity

These compact operating instructions apply to the following HMI devices in conjunction with the WinCC software package:

Comfort PRO devices 12"

Name	Article number
TP1200 Comfort PRO, suitable for support arm	6AV2124-0MC24-0AX0
TP1200 Comfort PRO, suitable for pedestal and extension components	6AV2124-0MC24-1AX0
TP1200 Comfort PRO, suitable for support arm and extension components	6AV2124-0MC24-0BX0

Comfort PRO devices 15"

Name	Article number
TP1500 Comfort PRO, suitable for support arm	6AV2124-0QC24-0AX0
TP1500 Comfort PRO, suitable for pedestal and extension components	6AV2124-0QC24-1AX0
TP1500 Comfort PRO, suitable for support arm and extension components	6AV2124-0QC24-0BX0

Comfort PRO devices 19"

Name	Article number
TP1900 Comfort PRO, suitable for support arm	6AV2124-0UC24-0AX0
TP1900 Comfort PRO, suitable for pedestal and extension components	6AV2124-0UC24-1AX0
TP1900 Comfort PRO, suitable for support arm and extension components	6AV2124-0UC24-0BX0

Comfort PRO devices 22"

Name	Article number
TP2200 Comfort PRO, suitable for support arm	6AV2124-0XC24-0AX0
TP2200 Comfort PRO, suitable for pedestal and extension components	6AV2124-0XC24-1AX0
TP2200 Comfort PRO, suitable for support arm and extension components	6AV2124-0XC24-0BX0

These compact operating instructions describe the technical differences of the Comfort PRO devices to the corresponding standard devices.

The information in these compact operating instructions take precedence in terms of their binding character over the statements in the underlying operating instructions, the release notes and the online help. The underlying operating instructions "Comfort Panels" are available on the Internet (<http://support.automation.siemens.com/WW/view/en/49313233>).

Unless otherwise described in this document, all specifications for the corresponding Comfort V2 device in the underlying operating instructions "Comfort Panels" apply to the Comfort PRO HMI devices, especially specifications regarding electronics, operating system, software, configuration, maintenance and service.

Note

This document belongs to the device and will also be required for repeat commissioning. Keep all supplied and supplementary documentation for the entire service life of the device. Provide all associated documents to any future owner of the device.

Please observe notes labeled as follows:

Note

A note contains important information about the product described in the manual and its use, or a specific section of the manual to which you should pay particular attention.

Naming conventions

Term	Applies to
System	<ul style="list-style-type: none"> • System • Machining center • One or more machines
PRO device, HMI device, device	All HMI devices listed under "Validity"
WinCC	WinCC V14 SP1 (TIA Portal) with one of the following HSPs: <ul style="list-style-type: none"> • "HSP 0226 HMI TP1200 Comfort PRO" or later for 12" PRO devices • "HSP 0212 HMI TP1500 - TP2200 Comfort PRO" or later for 15-22" PRO devices

Figures

This manual contains figures of the described devices. The figures can deviate from the particularities of the delivered device.

Picture components are marked with black position numbers on a white background ①, ②, ③, etc.

Steps in the figures are identified with white process numbers on a black background according to the sequence in which they have to be executed:

❶ , ❷ , ❸ , ...

Table of contents

	Preface	3
1	Overview	7
1.1	Product description.....	7
1.2	Software requirements	8
1.3	Scope of delivery.....	9
1.4	Configuration of the devices	10
1.4.1	PRO devices, suitable for support arm.....	10
1.4.2	PRO devices, suitable for pedestal and extension components.....	11
1.4.3	PRO devices, suitable for support arm and extension components	13
1.4.4	Interfaces	14
1.5	System components and accessories.....	15
1.5.1	System components for PRO devices.....	15
1.5.2	Accessories.....	18
2	Safety instructions	19
2.1	General safety instructions	19
2.2	Security management for HMI devices.....	21
2.3	Notes about usage	21
3	Mounting and connecting the HMI device	23
3.1	Preparing for installation.....	23
3.1.1	Checking the package contents.....	23
3.1.2	Checking the operating conditions	23
3.1.3	Permitted mounting positions.....	24
3.1.4	Installing a strain relief.....	25
3.2	Mounting the PRO device.....	26
3.2.1	Notes on mounting	26
3.2.2	PRO devices, suitable for support arm / pedestal and extension components	28
3.2.3	PRO devices, suitable for support arm and extension components	30
3.3	Connecting the PRO device.....	33
4	Commissioning the device.....	35
4.1	Notes on commissioning and operation	35
4.2	Memory concept.....	37
4.3	Changing the memory cards.....	39
5	Maintenance and care.....	41
5.1	Cleaning the device.....	41
5.2	Repair, spare parts, recycling and disposal.....	41

6	Technical information	42
6.1	Certificates and approvals	42
6.2	Electromagnetic compatibility	42
6.2.1	Emitted interference	42
6.2.2	Immunity to interferences	42
6.3	Mechanical ambient conditions	43
6.3.1	Storage conditions.....	43
6.3.2	Operating Conditions.....	43
6.4	Climatic ambient conditions	43
6.4.1	Long-term storage.....	43
6.4.2	Transport and short-term storage	44
6.4.3	Operating Conditions.....	44
6.5	Information on insulation tests, protection class and degree of protection.....	45
6.6	Dimension drawings	46
6.6.1	TP1200 Comfort PRO	46
6.6.2	TP1500 Comfort PRO	49
6.6.3	TP1900 Comfort PRO	52
6.6.4	TP2200 Comfort PRO	55
6.7	Specifications	58
6.8	Interface description	60
6.9	Scope of functions with WinCC.....	60
A	Technical Support.....	64
A.1	Service and support	64
A.2	Troubleshooting and system alarms	64
	Index.....	65

Overview

1.1 Product description

The SIMATIC HMI Comfort PRO devices with glass front have all-round IP65 and Type 4X/12 protection and complete the portfolio of the SIMATIC HMI Comfort devices. The rugged aluminum enclosure of the SIMATIC HMI Comfort PRO devices (PRO = Protected) allows for their use directly at the machine even under tough ambient conditions.

The SIMATIC HMI Comfort PRO devices can be mounted to a pedestal and connected to a support arm system either from above or below by means of a base adapter available from a variety of manufacturers. This means the SIMATIC HMI Comfort PRO devices can be used directly at the machine for ergonomic operation at different locations in a plant or production line.

The SIMATIC HMI Comfort PRO devices have a crystal clear, scratch-resistant and continuous glass front with high chemical resistance. Special features are industry-compliant antireflective coating as well as high image sharpness and brightness for good readability even with a large viewing angle. They also include automatic recognition of accidental touching and operating errors caused, for example, by resting the palm of your hand or contamination. The projective-capacitive touch (PCT) technology makes for efficient gesture and single-finger operation even with thin work gloves. Screen contents can, for example, be intuitively and quickly moved or supplemented by hidden components.

All devices offer the same excellent functionality and are configured exclusively with the innovative HMI software, WinCC. The engineering software is integrated in the engineering framework, "Totally Integrated Automation Portal".



Features

Front	<ul style="list-style-type: none"> • Continuous scratch-resistant glass front with antireflective coating and chemical resistance • Crystal clear TFT display with 16 million colors
Touch screen	<ul style="list-style-type: none"> • Capacitive single-touch screen • Suitable for operation with gloves, touch pen for capacitive touch screen and fingers
Interfaces	<ul style="list-style-type: none"> • 3 PROFINET interfaces • 1 PROFIBUS interface • 2 x USB 2.0 host port (Type A) • 2 x slot for SD memory card

Information and important notes on the interfaces and for connecting the devices are available in the following sections:

- Interfaces (Page 14)
- Connecting the PRO device (Page 33)

Mechanical differences to the standard product

Enclosure	Enclosure with all-round IP65 protection
Installation	Mounting to a support arm or stand with or without extension components
Interfaces	The interfaces including the slots for SD memory cards are located in the terminal compartment with Comfort PRO devices.

1.2 Software requirements







For configuring the PRO devices you need the WinCC V14 SP1 (TIA Portal) software with one of the following HSPs:

- "HSP 0226 HMI TP1200 Comfort PRO" or later for 12" PRO devices
- "HSP 0212 HMI TP1500 - TP2200 Comfort PRO" or later for 15-22" PRO devices

You can find the software under Technical Support on the Internet.

1.3 Scope of delivery

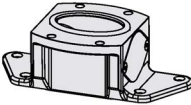
The following components are included in the scope of delivery of the HMI device.

Name	Figure	Number
HMI device		1
Installation instructions (Quick Install Guide)		1
Accessory pack with the following contents: <ul style="list-style-type: none"> • Power supply connector • Strain relief 		1
		1
Base adapter ¹		1
Cover for mechanical interface ²		1

¹ Only for PRO devices of the type "suitable for support arm" and "suitable for pedestal and extension components"

² Only for PRO devices of the type "suitable for support arm and extension components"

Some components in the scope of delivery are also available individually, see section "System components and accessories (Page 15)".

1.4 Configuration of the devices

1.4.1 PRO devices, suitable for support arm

The following figures show the design of the devices using TP1900 Comfort PRO suitable for support arm as an example.

Front view and side view



- ① Display with touch screen
- ② Enclosure
- ③ Backplane cover

Top view



- ① Mechanical interface for fastening

Rear view

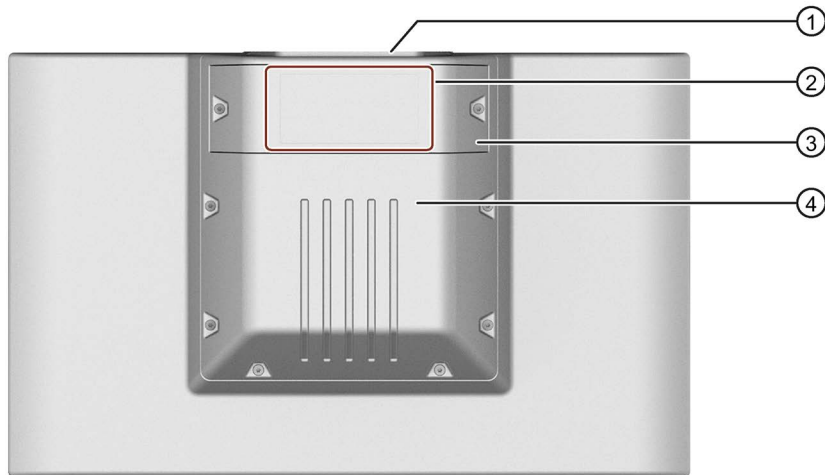

- ① Mechanical interface for fastening
- ② Rating plate
- ③ Terminal compartment cover
- ④ Backplane cover

1.4.2 PRO devices, suitable for pedestal and extension components

The following figures shows the design of the devices using TP1900 Comfort PRO suitable for pedestal and extension components as an example.

Front view and side view



- ① Display with touch screen
- ② Enclosure
- ③ Backplane cover

Bottom view

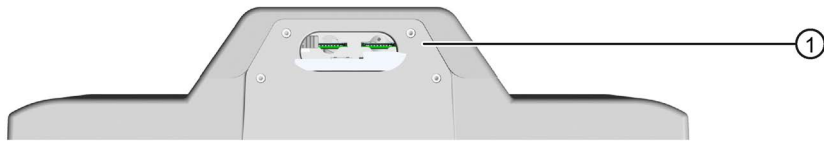

- ① Mechanical interface for fastening

Rear view

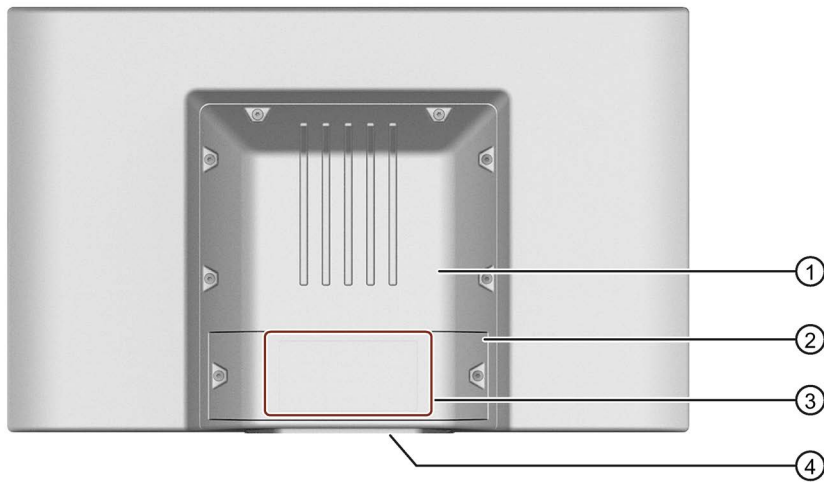

- ① Backplane cover
- ② Terminal compartment cover
- ③ Rating plate
- ④ Mechanical interface for fastening

1.4.3 PRO devices, suitable for support arm and extension components

The following figures show the design of the devices using TP1900 Comfort PRO suitable for support arm and extension components as an example.

Front view and side view



- ① Display with touch screen
- ② Enclosure
- ③ Mechanical interface for fastening (round tube)
- ④ Terminal compartment cover
- ⑤ Mechanical interface below

Rear view



- ① Mechanical interface for fastening (round tube)
- ② Terminal compartment cover
- ③ Nameplate
- ④ Mechanical interface below
- ⑤ Lower cover, included in the product package

1.4.4 Interfaces

All Comfort PRO devices

The figure below shows the interfaces of the Comfort PRO devices:

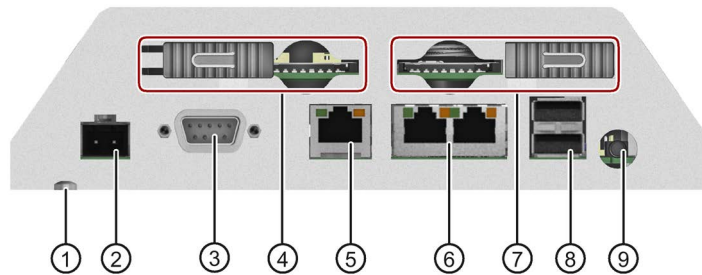

- | | |
|--|--|
| ① Connection for equipotential bonding (ground) | ⑥ X1 PROFINET (LAN), 10/100 Mb |
| ② X80 power supply connector | ⑦ X51 slot for SD data memory card with safety catch |
| ③ X2 PROFIBUS (Sub-D RS422/485) | ⑧ X61 / X62 USB type A |
| ④ X50 slot for SD system memory card with safety catch | ⑨ X90 Audio Line OUT |
| ⑤ X3 PROFINET (LAN), 10/100/1000 Mb | |

System memory card

Use a SIMATIC HMI Memory Card ≥ 2 GB as system memory card in slot X50.

Data memory card

Use a memory card in "SD(IO / HC)" or "MMC" format as data memory card in slot X51.
Recommendation: Use the SIMATIC HMI Memory Card.

Additional information

Use the X1 or X60 interface to connect a configuration PC. Use the X61 / X62 interfaces to connect peripheral devices such as a printer or keyboard. Use the X90 interface to connect a loudspeaker.

At interface X2 use a PROFIBUS connector with a 45° angle to the right.

Read the notes on connecting the devices in section "Connecting the PRO device (Page 33)".

Ordering information for memory cards is available in the section "Accessories (Page 18)".

1.5 System components and accessories

System components are products that were developed for a specific system and cannot be used for other systems, for example, the base adapter. System components are always directly related to a core product.

Accessories can typically be used for multiple devices from the same or different device families, for example, batteries, touch pens or protective membranes.

1.5.1 System components for PRO devices

Base adapter

PRO devices of the type "suitable for support arm" or "suitable for pedestal" can be mounted on the support arm or pedestal using the base adapter. A base adapter is included with the corresponding PRO devices. The base adapter can also be ordered separately.

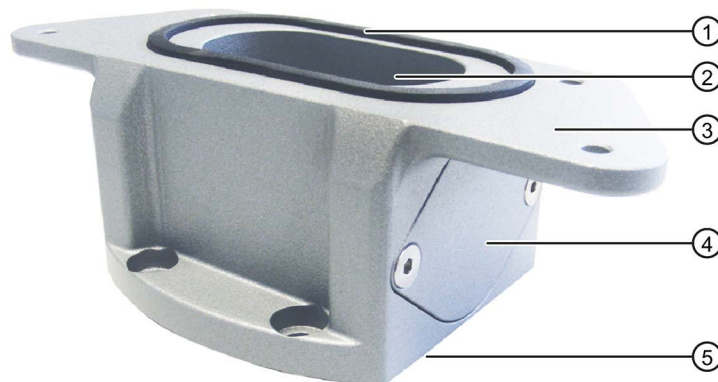

- ① Seal
- ② Channel cable
- ③ Mechanical interface to the PRO device
- ④ Cover
- ⑤ Mechanical interface to the support arm or pedestal including seal

Article number: 6AV7674-1KA00-0AA0

Adapter sets and couplings

The following mechanical adapter versions are also available for mounting a PRO device of the types "suitable for support arm" and "suitable for pedestal" via the base adapter:

- A Siemens VESA adapter set for VESA compatible systems
- Manufacturer-specific adapters or couplings

The following table shows the available Siemens adapter sets and examples of vendor-specific adapter versions:

Adapter version	Suitable for supporting arm systems	Article number
SIEMENS		
• Adapter set VESA75	VESA75-compatible systems	6AV7674-0KE00-0AA0
• Adapter set VESA100	VESA100-compatible systems	6AV7674-0KD00-0AA0
RITTAL		
Adapter for Siemens PRO Panel • Intermediate plate • Screws	• CP40 steel • CP60/120 for support arm connection 120 × 65 mm	6206.500
ROLEC		
Adapter for Siemens PRO Panel • Intermediate plate • Screws	• profiPlus-50 • taraPLUS for Ø 65 mm hole circle	142.024.000
BERNSTEIN		
Coupling for Siemens SIMATIC PRO • No intermediate plate required • Coupling with integrated adaptation for PRO devices	• CS-3000	• 1015300187 RAL 9006 White aluminum • 1015300043 RAL 7016 Anthracite grey

All information subject to change.

Flange mount

A flange mount is available for mounting a PRO device of the type "suitable for support arm and extension components".

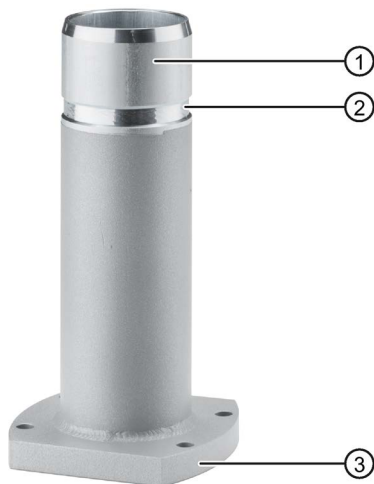

- ① Flange mount
- ② Ring groove for fastening on PRO device with setscrews
- ③ Mechanical interface to support arm

Article number: 6AV7674-1KF00-0AA0

Extension components - Extension Unit

The Extension Unit is used to install additional operator controls below a SIMATIC PRO device of type "Suitable for extension components" with 16:9 display.

By way of example, the figure below shows the Extension Unit 22" with eight operator controls including Emergency Stop button.



The operator controls on the Extension Units can be customized. The Extension Units come without operator controls. The possible mounting spaces are prepared for installation of operator controls.

The Extension Units are available in four sizes:

- Extension Unit 12"
- Extension Unit 15"
- Extension Unit 19"
- Extension Unit 22"

In each Extension Unit size, you have the flexibility to choose between the following interface variants for connection to the system:

- Hardwired
- PROFINET
- PROFIsafe

In addition, different operator controls, such as Emergency Stop pushbutton, selector switch, illuminated pushbutton, keyswitch, indicator light and RFID reader, are available.

Note

Only operator controls with Siemens approval may be installed in the Extension Unit.

Additional information

Additional information on system components for devices with all-round IP65 protection and extension components, such as IP65 keyboard, keyboard tray or USB port, is available on the Internet (<https://mall.industry.siemens.com/mall/en/WW/Catalog/Products/10268745>).

1.5.2 Accessories

An accessory kit with the necessary accessories is included with the HMI device. Additional accessories can be found on the Internet (<https://mall.industry.siemens.com/mall/en/WW/Catalog/Products/10144445>).

This section contains the number of accessories available at the time of publication of the operating instructions.

HMI I/O components

Name	Article number
45° PROFIBUS connector for RS422/RS485 interface	6ES7972-0BA42-0XA0
Plug for the power supply of the HMI device	6AV6671-8XA00-....

"...." stands for the variant key of the article number.

Storage media

Use only the following storage media for the HMI device.

Name	Article number
SIMATIC HMI Memory Card	6AV2181-8XP00-....
SIMATIC HMI USB stick	6AV2181-8AS20-....

"...." stands for the variant key of the article number.

Other accessories

Additional USB accessories can be found on the Internet in the following entry: FAQ 19188460 (<https://support.industry.siemens.com/cs/ww/en/view/19188460>).

Input help

Name	Article number
Touch pen system for resistive and capacitive touch systems	6AV2181-8AV20-...

"...." stands for the variant key of the article number.

Safety instructions

2.1 General safety instructions

Open equipment and the Machinery Directive

 WARNING
<p>Electrocution risk when control cabinet is open</p> <p>When you open the control cabinet, there may be a dangerous voltage at certain areas or components.</p> <p>Touching these areas or components can cause electrocution.</p> <p>Always disconnect the cabinet from the mains before opening it.</p> <p>The device may only be used in machines which comply with the Machinery Directive</p> <p>The Machinery Directive specifies precautions to be taken when commissioning and operating machinery within the European Economic Area.</p> <p>Failure to follow these precautions is a breach of the Machinery Directive. Such failure may also cause personal injury and damage depending on the machine operated.</p> <p>The machine in which the HMI device is to be operated must conform to Directive 2006/42/EC.</p>

Hazardous areas

When operating the HMI device in hazardous areas the following warning applies.

 WARNING
<p>Explosion Hazard</p> <p>Do not disconnect while circuit is live unless area is known to be non-hazardous. Substitution of components may impair suitability for Class I, Division 2 or Zone 2.</p> <p>Risque d'Explosion</p> <p>Ne pas déconnecter pendant que le circuit est sous tension, sauf si la zone est non-dangereuse. Le remplacement de composants peut compromettre leur capacité à satisfaire à la Classe I, Division 2 ou Zone 2.</p>

Strong high-frequency radiation

NOTICE

Observe immunity to high-frequency radiation

The device has an increased immunity to high frequency radiation according to the specifications on electromagnetic compatibility in the technical specifications.

Radiation exposure in excess of the specified immunity limits can impair device functions and result in malfunctions and therefore injuries or damage.

Read the information on immunity to high frequency radiation in the technical specifications.

ESD



An electrostatically sensitive device is equipped with electronic components. Due to their design, electronic components are sensitive to overvoltage and thus to the discharge of static electricity. Note the corresponding regulations when handling ESD.

Industrial Security

Siemens provides products and solutions with industrial security functions that support the secure operation of plants, systems, machines and networks.

In order to protect plants, systems, machines and networks against cyber threats, it is necessary to implement – and continuously maintain – a holistic, state-of-the-art industrial security concept. Siemens' products and solutions only form one element of such a concept.

Customer is responsible to prevent unauthorized access to its plants, systems, machines and networks. Systems, machines and components should only be connected to the enterprise network or the internet if and to the extent necessary and with appropriate security measures (e.g. use of firewalls and network segmentation) in place.

Additionally, Siemens' guidance on appropriate security measures should be taken into account. For more information about industrial security, please visit (<http://www.siemens.com/industrialsecurity>).

Siemens' products and solutions undergo continuous development to make them more secure. Siemens strongly recommends to apply product updates as soon as available and to always use the latest product versions. Use of product versions that are no longer supported, and failure to apply latest updates may increase customer's exposure to cyber threats.

To stay informed about product updates, subscribe to the Siemens Industrial Security RSS Feed under (<http://www.siemens.com/industrialsecurity>).

Disclaimer for third-party software updates

This product includes third-party software. Siemens AG only provides a warranty for updates/patches of the third-party software, if these have been distributed as part of a Siemens software update service contract or officially released by Siemens AG. Otherwise, updates/patches are undertaken at your own risk. You can find more information about our Software Update Service offer on the Internet at Software Update Service (<http://www.automation.siemens.com/mcms/automation-software/en/software-update-service>).

Notes on protecting administrator accounts

A user with administrator privileges has extensive access and manipulation options in the system.

Therefore, ensure there are adequate safeguards for protecting the administrator accounts to prevent unauthorized changes. To do this, use secure passwords and a standard user account for normal operation. Other measures, such as the use of security policies, should be applied as needed.

2.2 Security management for HMI devices

You can find additional information on security management of HMI devices on the Internet at the following address:

Panel Security Guidelines (<https://support.industry.siemens.com/cs/de/en/view/109481300>)

2.3 Notes about usage

NOTICE
The HMI device is approved for indoor use only.
The HMI device may be damaged if it is operated outdoors.
Operate the HMI device indoors only.

Note**Operate the device only in a normal atmospheric environment**

The technical characteristics of the device described in the operating instructions are guaranteed if you operate the device in normal ambient air conditions with usual air composition.

Industrial applications

The HMI device is designed for industrial applications. It conforms to the following standards:

- Requirements for emissions EN 61000-6-4: 2007
- Requirements for interference immunity EN 61000-6-2: 2005

Use in mixed-use zone

Under certain circumstances you can use the HMI device in a mixed-use zone. A mixed-use zone is used for housing and commercial operations that do not have a significant impact on residents.

When you use the HMI device in a mixed-use zone, you must ensure that the limits of the generic standard EN 61000-6-3 regarding emission of radio frequency interference are observed. Suitable measures for achieving these limits for use in a mixed-use zone include:

- Installation of the HMI device in grounded control cabinets
- Use of filters in electrical supply lines

Individual acceptance is required.

Use in residential areas

Note

HMI device not intended for use in residential area

The HMI device is not intended for use in residential areas. Operation of an HMI device in residential areas can have a negative influence on radio or TV reception.

Use with additional measures

The HMI device should not be used at the following locations unless additional measures are taken:

- In locations with a high degree of ionizing radiation
- In locations with severe operating conditions, for example, due to:
 - Corrosive vapors, gases, oils or chemicals
 - Strong electrical or magnetic fields of high intensity
- In systems that require special monitoring, for example, in:
 - Elevators
 - Systems in especially hazardous rooms

Mounting and connecting the HMI device

3.1 Preparing for installation

3.1.1 Checking the package contents

Check the package content for visible signs of transport damage and for completeness.

Note**Damaged parts**

A damaged part will cause the HMI device to malfunction.

Do not install parts damaged during shipment. In the case of damaged parts, contact your Siemens representative.

Check the scope of supply of the HMI device (see Scope of delivery (Page 9)).

Additional documents may be included in the delivery.

The documentation is part of the HMI device and is required for subsequent commissioning. Keep all enclosed documentation for the entire service life of the HMI device. You must pass along the enclosed documentation to any subsequent owner or user of the HMI device.

Make sure that every supplement to the documentation that you receive is stored together with the operating instructions.

3.1.2 Checking the operating conditions

Note the following aspects before installing the HMI device:

1. Familiarize yourself with the technical specifications for operating the HMI device. You can find this information in the section "Technical information (Page 42)".
2. Read the information about local use of the HMI device, see section "Notes about usage (Page 21)".

3.1.3 Permitted mounting positions

The device is intended for mounting on a support arm or stand.

The following figures show the permissible mounting positions of the different PRO devices.

PRO devices, suitable for support arm / pedestal and extension components

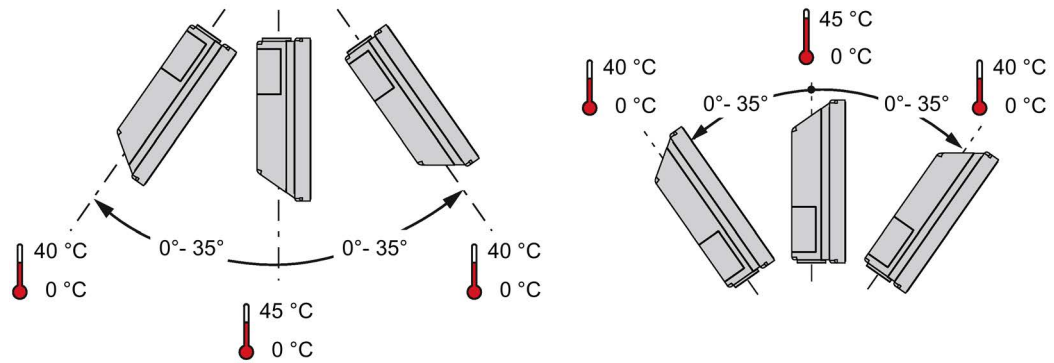

PRO devices, suitable for support arm and extension components

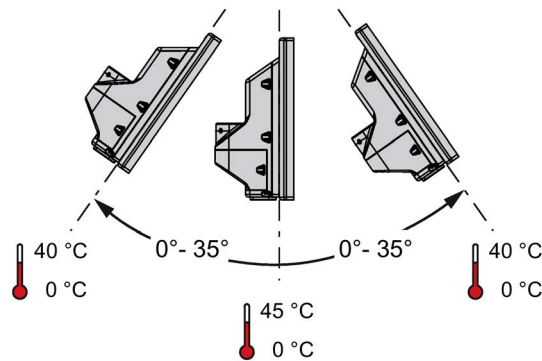

Ambient conditions

Note

No extended inclination and ambient temperature range for Comfort PRO devices

The information on the extended inclination and ambient temperature range in the Comfort Panels operating instructions does not apply to the Comfort PRO devices.

For information regarding the permitted ambient temperatures, refer to section "Climatic ambient conditions (Page 43)".

3.1.4 Installing a strain relief

Install the strain relief in the terminal compartment as follows:

1. Loosen the two screws of the terminal compartment cover and remove the terminal compartment cover.
2. Fasten the strain-relief with the screws intended for this purpose, torque 0.8 Nm.

In the delivery state, the screws are already pre-installed in the terminal compartment.

The figure below shows a PRO device of the type "suitable for pedestal and extension components" as an example.

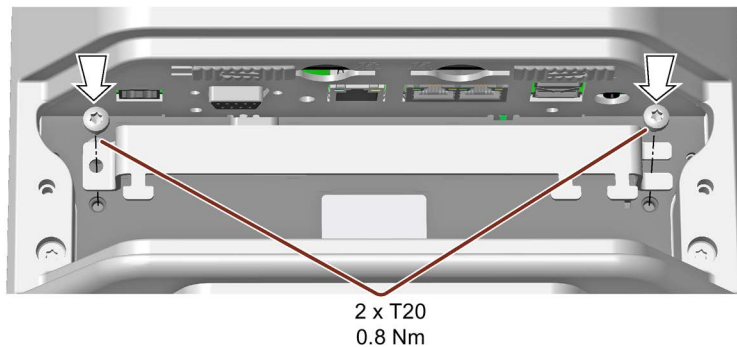

The figure can also be used for a PRO device of the type "suitable for support arm and extension components".

For PRO devices of the type "suitable for support arm", the strain relief is to be installed rotated by 180°.

3. If you do not install the device to a support arm or a pedestal immediately afterwards, close the terminal compartment. Fasten the terminal compartment cover with the two associated screws, torque 1.5 Nm. Check that the seal is sitting correctly.

3.2 Mounting the PRO device

3.2.1 Notes on mounting

 **WARNING**

The device must be mounted securely.

Inadequately dimensioned fasteners may cause the device to fall down. Serious physical injury may result.

Make sure that fasteners are adequately dimensioned during installation. Make sure to consider the weight of the device and the forces acting on the device when dimensioning. This applies in particular to dynamic load of the device. All fasteners including mounting surfaces, support arm systems, and fastening elements such as screws must be able to carry at least four times the weight of the device.

Observe any further statutory specifications applying at the location of use of the device and further applicable regulations with regard to fastening the device.

Pay attention to the torque specifications in the following sections.

NOTICE

Degree of protection for overall device

If you are using a support arm system or a pedestal system that does not have IP65 degree of protection or Enclosure Type 4X/12 (indoor use only), IP65 degree of protection or Enclosure Type 4X/12 (indoor use only) are lost for the entire device. Spray and water jets as well as penetrating substances can then damage the device.

Use a suitable support arm system or pedestal system with IP65 degree of protection or Enclosure Type 4X/12 (indoor use only) for your application.

Note

Liability disclaimer

The device is mounted to a pedestal or a support arm via the mechanical interface with screws. Siemens AG assumes no liability for the consequences of incorrect installation.

Warranty at risk

If you do not install the HMI device in accordance with the specifications in these operating instructions, the warranty for the device is voided.

- Always install the device according to these operating instructions.
- If the seal on the backplane cover is damaged, it can be repaired. For a repair scenario, following the instructions in the section "Repair, spare parts, recycling and disposal (Page 41)".

IP65 degree of protection and Enclosure Type 4X/12 (indoor use only) at risk

If there are no seals on the mechanical interfaces or if they are damaged, IP65 degree of protection and Enclosure Type 4X/12 (indoor use only) is at risk. Check the condition and proper seating of the seals.

<p>NOTICE</p>

<p>Damaging the seal when opening</p>
--

<p>If the device has not been opened for a long time, the backplane cover or terminal compartment cover may stick to the seal of the enclosure. Opening the device with excessive force or with tools will destroy the seal. Spray and water jets as well as penetrating substances can then damage the device.</p>

<p>Open the terminal compartment cover gently, without too much pressure.</p>

3.2.2 PRO devices, suitable for support arm / pedestal and extension components

Note

Mounting with and without a base adapter

The SIMATIC PRO devices are designed for mounting with the base adapter. If you install the device without a base adapter, you must adjust the mechanical interface between the support arm or pedestal and the unit accordingly, including placement of an appropriate seal on the mechanical interface.

Requirement

- All packaging components and protective films have been removed.
 - Siemens base adapter with screws, included in the scope of delivery of a PRO device of type "suitable for support arm" or "suitable for pedestal and extension components".
 - One of the following support arms or pedestal systems:
 - Support arm or pedestal with mechanical VESA interface and the corresponding Siemens adapter set
 - Support arm or pedestal with mechanical interface for the Siemens base adapter
The type of mechanical interface differs depending on the type of support arm or pedestal.
- See also section "System components for PRO devices (Page 15)".
- The following cables are fed through the pedestal or the support arm to which the device is mounted:
 - Protective conductor
 - Equipotential bonding cable
 - Data cables, such as PROFIBUS, PROFINET or USB cable
Recommendation: Route large connectors, such as PROFIBUS connectors and their cables, through the pedestal or support arm first.

Procedure

This section describes the mounting of the device to a support arm system using example figures. Installation on a pedestal is carried out in the same way. For devices of the type "suitable for support arm", the base adapter is screwed to the device from the top; for devices of the type "suitable for pedestal", it is screwed from below. A device for a support arm system cannot be used on a pedestal, and vice versa.

1. If an adapter plate for the Siemens base adapter is included in your support arm system, attach the adapter plate to the support arm with 4 M6x12 screws. Pay attention to the torque that is specified for the support arm.

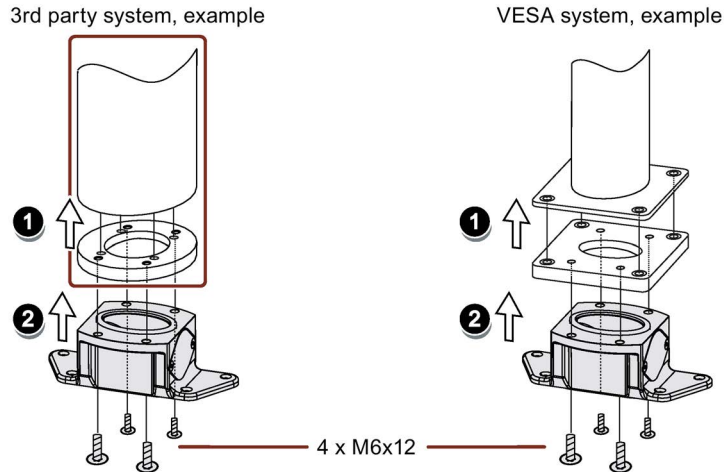

2. Attach the base adapter with 4 M6x12 screws to the mechanical interface of the support arm from below. Pay attention to the torque that is specified for the support arm.
3. Loosen the 2 screws of the terminal compartment cover and remove the terminal compartment cover.

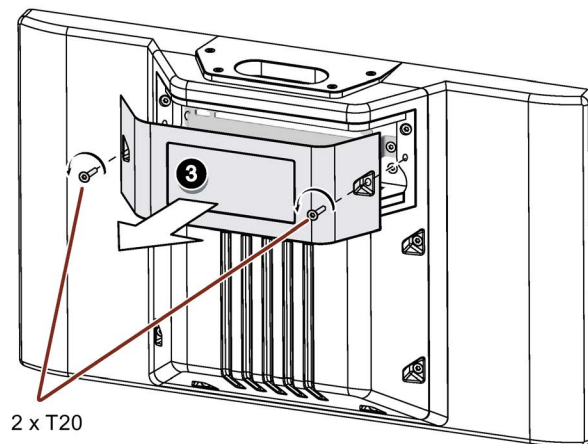

4. Insert all connection cables through the opening of the PRO device. Make sure that the connection cables are not damaged.

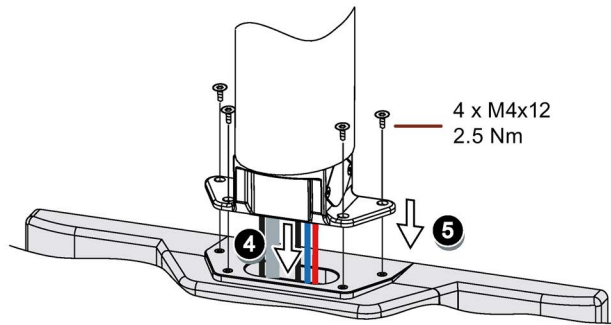

5. Attach the device with 4 M4x12 screws to the base adapter from the top, torque 2.5 Nm. Make sure that the connection cables are not crushed.
6. Connect all cables according to the description in the section below.
7. Fasten the terminal compartment cover to the device with the 2 screws, torque 1.5 Nm. Check that the seal is sitting correctly.

3.2.3 PRO devices, suitable for support arm and extension components

Requirement

- One of the following support arm systems:
 - Support arm with round tube end with outside diameter 48.3 mm, appropriate for the opening of the PRO device
When selecting the round tube, ensure that its inside diameter is large enough so that all needed cables and their connectors can fit through.
 - Support arm with mechanical interface, appropriate for the flange of the flange mount, and Siemens flange mount (not included in scope of delivery)
 - Support arm with mechanical VESA interface, the corresponding Siemens adapter set and the Siemens flange mount (not included in scope of delivery)
- See also section "System components for PRO devices (Page 15)".
- The PRO device, all packaging components and protective films have been removed
 - The lower cover of the PRO device from the accessory kit
 - The following cables are fed through the support arm to which the device is mounted:
 - Protective conductor
 - Equipotential bonding cable
 - Data cables, such as PROFIBUS, PROFINET or USB cable
Recommendation: Route large connectors, such as PROFIBUS connectors and their cables, through the pedestal or support arm first.

Procedure

The following figures show an example of how to attach the PRO device to a support arm system using the optionally available Siemens flange mount. The same approach is used to mount the PRO device to a 48.3 mm round tube.

1. Loosen the 2 screws of the terminal compartment cover and remove the terminal compartment cover.

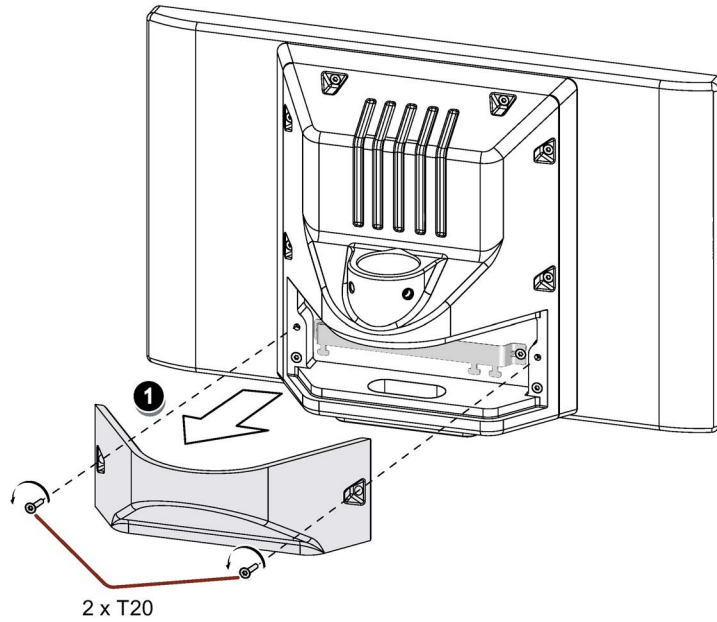

2. Grease the round tube adapter or 48.3 mm round tube with grease suitable for NBR seals, and insert the flange mount or 48.3 mm round tube into the corresponding opening of the PRO device.

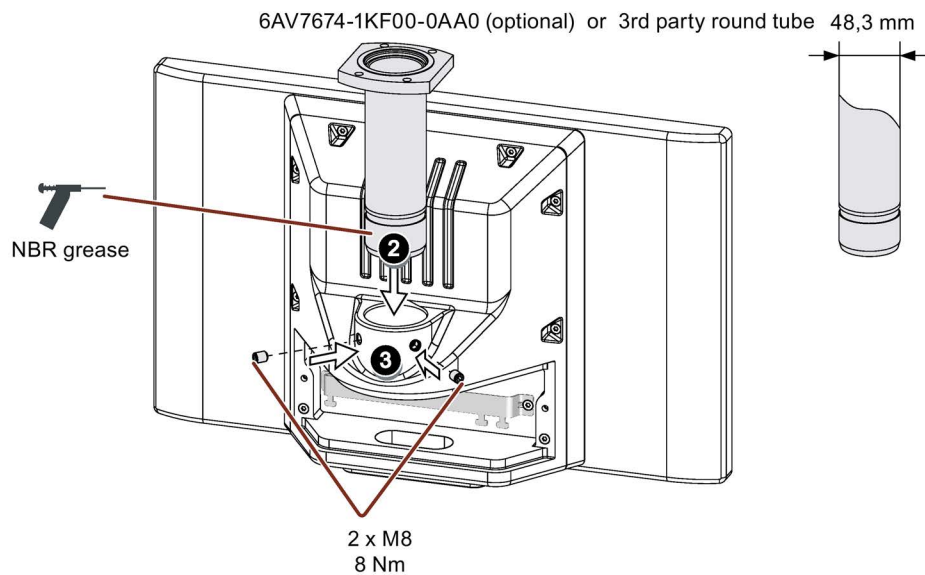

3.2 Mounting the PRO device

3. Attach the flange mount or the 48.3 mm round tube with the two M8 threaded pins. Observe the appropriate torque:
 - Siemens flange mount: 8 Nm
 - 48.3 mm steel round tube 8 Nm
 - 48.3 mm aluminum round tube: 5 Nm
4. If an adapter plate for the Siemens flange mount is included with your support arm, attach the adapter plate to the support arm with 4 M6x12 screws. Pay attention to the torque that is specified for the support arm.

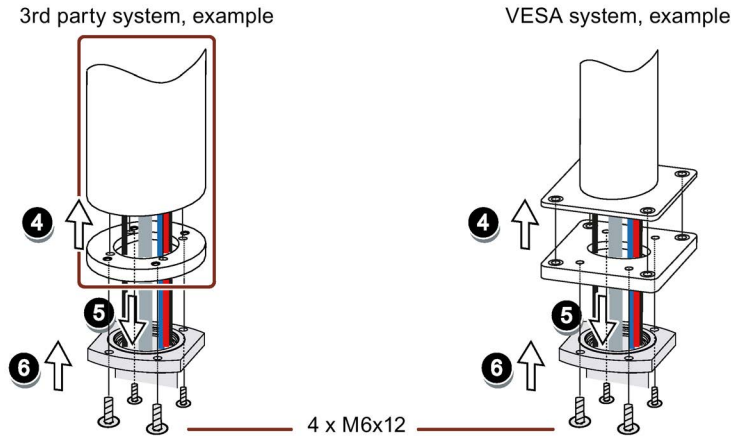

5. Insert all connection cables through the opening of the flange mount or 48.3 mm round tube into the connection compartment of the PRO device. Make sure that the connection cables are not damaged.
6. Attach the device with 4 M4x12 screws to the support arm from the below. The screws are not included in the product package of the PRO device. Pay attention to the torque that is specified for the support arm. Make sure that the connection cables are not crushed.
7. Connect all cables according to the description in the section below.
8. Fasten the terminal compartment cover to the device with the 2 screws, torque 1.5 Nm. Check that the seal is sitting correctly.
9. Attach the lower cover supplied with the PRO device with 4 M4x12 screws, torque 1.5 Nm. Alternatively, you can extend the PRO device by adding an Extension Unit at the bottom. Observe the associated documentation.

See also

System components for PRO devices (Page 15)

3.3 Connecting the PRO device

The specifications for Comfort V2 devices in the "Comfort Panels" operating instructions apply.

You should also observe the following notes.

Note**Cable routing**

As the PRO device is not installed in a control cabinet but on a pedestal or support arm, the connecting cables must be routed through the support arm or the pedestal.

Make sure to consult the corresponding connection diagrams in the Quick Install Guide supplied with your PRO device.

Connecting the controller

Note**PROFIBUS connector with 45° cable outlet necessary**

When you connect the HMI device over PROFIBUS, you are using a PROFIBUS connector with 45° cable outlet. We recommend the PROFIBUS connector with article number 6ES7972-0BA42-0XA0.

Note**Connecting PROFIBUS and PROFINET**

When you connect the HMI device over PROFIBUS and PROFINET, the interface X3 PROFINET (LAN) is covered up by the cable of the PROFIBUS connector with 45° cable outlet. Use one of the two X1 PROFINET (LAN) interfaces for PROFINET in this case.

Securing the cables

Secure the connected connectors and cables with cable ties to the corresponding fastening elements of the strain relief. You must secure at least those connectors that do not snap into place in the socket or cannot be fastened with screws.

The figure below shows an example of how you can secure connectors and cables of a PRO device of the type "suitable for pedestal and extension components".

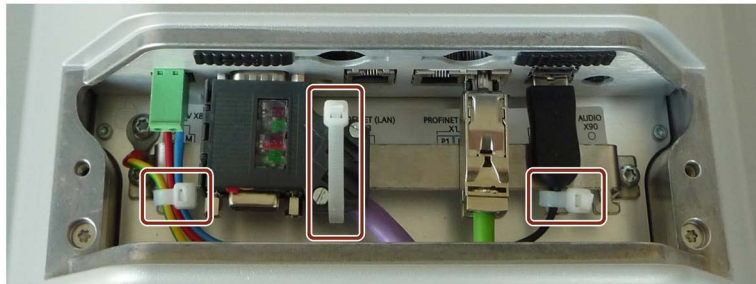



Commissioning the device

4.1 Notes on commissioning and operation

 WARNING
Personal injury or property damage due to no earth connection An inadequate earth connection or the lack of one may cause malfunction of the capacitive touch screen. Functions may not work properly. This can result in personal injury or property damage. <ul style="list-style-type: none">• Always connect the device to an earth conductor.• The earth conductor from the device must be connected directly to earth with low impedance (short connection, minimum cross-section 4 mm²).

You can find additional information on connecting the earth conductor in the section "Connecting the equipotential bonding" of the "Comfort Panels" operating instructions.

 WARNING
Personal injury or property damage due to maloperation Incorrect operation of devices with a touch screen can occur. This can result in personal injury or property damage. Take the following precautions: <ul style="list-style-type: none">• Configure the plant so that safety-related functions are not operated with the touch screen.• Switch off the device for cleaning and maintenance.

 WARNING
Danger of malfunction due to improper execution of gestures on the touch screen If gestures are executed incorrectly on the capacitive single-touch screen, these gestures may not be recognized or could be recognized incorrectly. The entries made are then not implemented by the device or are implemented incorrectly or in an unintended manner. Incorrect execution of the functions can lead to errors in the operation of the plant and thus to physical injury. Note when operating the capacitive single-touch screen: <ul style="list-style-type: none">• The touch screen reacts to contact on its surface, not to pressure.• When using a touch pen: Operate the touch screen only with a touch pen for capacitive touch.• Avoid unintended multiple touches, for example, with your knuckles.

Notes on operation

Note

Do not touch the touch screen during startup

The device automatically calibrates the capacitive single-touch screen during startup. The touch screen is locked during calibration.

Do **not** touch the touch screen during startup. Make sure that you do **not** rest on the touch screen with the palm of your hand during startup.

Make sure that there are **no** conductive liquids on the touch screen during startup.

Note when operating the capacitive single-touch screen:

- Surface contact with a diameter of about 5 to 20 mm is required for an operator action to be detected.
- An operation with gloves with a material thickness of <2 mm is detected in most cases. However, check the usefulness of the gloves you are using.
- To avoid incorrect operation, certain inputs are ignored and blocked from further entry:
 - Simultaneous operation with multiple fingers.
 - Surface contact with a diameter of > 3 cm, for example, resting the palm of the hand on the touch screen
 - As soon as the touch screen is no longer touched, input is possible again.

Functions of the capacitive single-touch screen

General functions

- Automatic calibration of the touch screen during startup; manual calibration is not necessary. For this reason the "Touch" tab does not exist in the "OP Properties" dialog for PRO devices.
- Touch and gesture operation analog to the operating options described in the "Comfort Panels" operating instructions.

Security functions in an industrial environment

The touch screen is locked for security reasons when following happens:

- There is a conductive liquid on the touch screen with ground contact via the enclosure or the operator, for example.
- Electromagnetic interference is present that exceeds the specification according to EN 61000-4-2.

Once the interference is over, the touch screen is no longer locked.

4.2 Memory concept

The HMI devices use the following memory types:

- **Internal memory**
- **Memory card** for data and logs
- **System memory card** for "automatic backup"
- USB port for a **USB storage medium** with data

Note

Always use the memory card instead of the USB port for logs.

Internal memory

The following data is saved in the internal memory:

- Operating system
- Project file
- License keys
- User administration
- Recipes*
- Other data, such as documents or media files

* To store recipes in the internal memory, select "\\Flash\\" as the path in WinCC.

Note

Cyclic write access to the internal memory is not permitted

Cyclic write access to internal memory is not permitted, because it reduces the service life of the internal memory and of the HMI device, for example, during configuration in which permanent system messages or user-defined messages are generated in the alarm buffer.

Configure an alarm window, check the number and frequency of the alarms that occur, and adjust the configuration accordingly if you expect a permanent load on the internal memory from alarms.

To prolong the service life of your device, you should preferably use external memory cards to store and log data, such as the SIMATIC HMI Memory Card.

Note

Number of permitted files in the root directory of the internal memory

The number of files in the root directory is limited to 256. The number of files is not limited in the subdirectories of the internal memory.

Memory card

The following data is saved on the memory card:

- Logs
- Data backups
- User data
- Recipes*)

*) To store recipes on the memory card, select "\Storage Card SD\" as the path in WinCC.

You can use commercially available memory cards with the "SD(IO / HC)" or "MMC" format. For reasons of data consistency, Siemens recommends the use of the SIMATIC HMI Memory Card as memory card, see AUTOHOTSPOT.

Note

Data consistency

When the HMI device is switched off, consistency of the stored data is ensured only for the SIMATIC HMI Memory Card ≥ 2 GB.

With commercially available memory cards, switching off the device may result in the loss of saved data, for example, due to a power failure.

The consistency of data stored in logs is only guaranteed if you use RDB format.

Frequency

Logs are stored at a frequency of approx. 0.2 Hz. Therefore, small amounts of data may be lost shortly before a power failure.

Use a UPS to avoid data loss even shortly before a power failure.

System memory card

The system memory card is part of the service concept of the HMI devices. If you enable the "automatic backup" function, all data from the internal memory of the HMI device is transferred to the system memory card. If the HMI device fails, you insert the system memory card into a replacement device. Once the replacement device starts, you can continue working in your project. This way you reduce your system downtimes to a minimum.

The system memory card is not visible in the user interface of the HMI device and it cannot be used for data storage. In order for the HMI device to recognize the system memory card, you have to insert the system memory card into the slot designed for it.

Note

Format of the system memory card

Only a SIMATIC HMI Memory Card ≥ 2 GB may be used as a system memory card. All other memory cards are not recognized as system memory card by the HMI device.

Slots for memory card and system memory card

The memory cards and system memory cards are protected by a safety catch. The memory cards and system memory cards can be hot-swapped during ongoing operation of the HMI device.

The figure below shows the slots with safety catch.

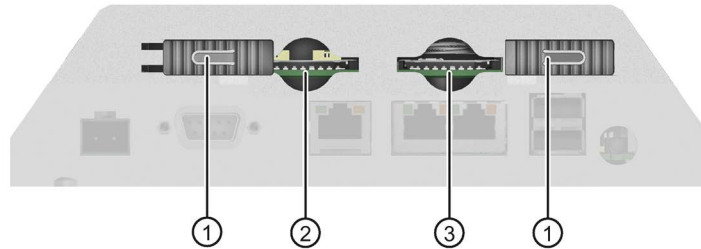

- ① Safety catch
- ② Slot for the system memory card.
Permitted: SIMATIC HMI Memory Card ≥ 2 GB
- ③ Slot for memory card in the "SD(IO / HC)" or "MMC" format.
Recommendation: SIMATIC HMI memory card

4.3 Changing the memory cards

Introduction

The memory cards and system memory cards are protected by a safety catch. The memory card and system memory card can be hot-swapped during ongoing operation of the HMI device.

Note

Potential loss of data

The data on the memory card is lost if you attempt to remove it while the HMI device is accessing its data.

Do not remove the memory card while data is being accessed. Observe the corresponding alarms on the screen.

Removing the system memory card while the project is running

If you remove the system storage card while a project is running, the project is ended.

Requirement

No write access to the memory and/or system memory card is currently taking place.

Procedure

Note

Use only a SIMATIC HMI memory card as a system memory card

Only the SIMATIC HMI Memory Card ≥ 2 GB may be used as a system memory card. All other memory cards are not recognized as system memory card by the HMI device.

Proceed as follows:

1. Push the safety catch to the outside.
2. To remove the memory card and/or system memory card, briefly press the card in question.

The card will be released and can be removed. This step is not required during commissioning.

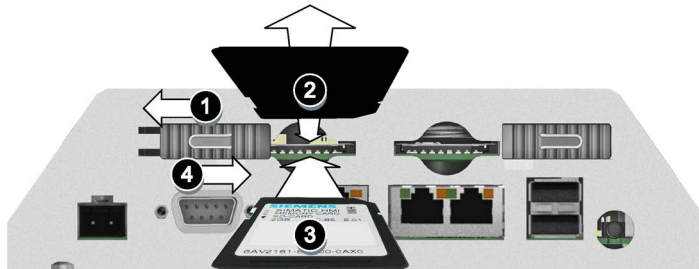

3. Insert the new memory card and/or system memory card.
4. Slide the safety catch back into its original position.

When you have inserted the system memory card, you will be prompted by the HMI device to enable the "Automatic Backup" function.

The memory card and/or system memory card is replaced.

Maintenance and care

5.1 Cleaning the device

The specifications in "Comfort Panels" operating instructions apply.

NOTICE
Disable or switch off the device while cleaning
Switch off the HMI device or activate the clean screen when you clean the appliance during operation.

Note**Cleaning of the coated glass touch screen**

Take care not to damage the glass touch screen and the coating of the touch screen on Comfort PRO devices.

Use a cleaning cloth and dishwashing liquid or foaming screen cleaners. Apply as little pressure as possible on the touch screen when cleaning.

5.2 Repair, spare parts, recycling and disposal

The specifications in "Comfort Panels" operating instructions apply.

Technical information

6.1 Certificates and approvals

Approvals

The device is certified as shown on the rear of the device.

As soon as additional certificates are available, you can find them in the Industry Mall or Technical Support.

Search for your device and use the link "Support > Approvals / Certificates".

6.2 Electromagnetic compatibility

The device is designed for industrial use.

6.2.1 Emitted interference

The device meets the requirements according to EN 61000-6-4.

Note

The HMI device is not intended for use in residential areas. Operation of an HMI device in residential areas can have a negative influence on radio/TV reception.

6.2.2 Immunity to interferences

The device meets the requirements according to EN 61000-6-2.

6.3 Mechanical ambient conditions

6.3.1 Storage conditions

The following information is for a device that is transported and stored in its original packaging.

The device meets the requirements according to IEC 60721-3-2 Class 2M2 with the following amendments and limitations:

Type of condition	Permitted range
Free fall	≤ 1 m
Vibration to IEC 60068-2-6	5 .. 8.4 Hz, deflection 3.5 mm 8.4 ... 500 Hz, acceleration 1 g
Shock to IEC 60068-2-27	250 m/s ² , 6 ms, 1000 shocks

6.3.2 Operating Conditions

The following information applies to a device installed according to the specifications in these operating instructions.

The device meets the requirements according to IEC 60721 Class 3M3 with the following amendments and limitations:

Type of condition	Permitted range
Vibration to IEC 60068-2-6	5 ... 8.4 Hz, deflection 3.5 mm 8.4 ... 200 Hz, acceleration 1 g
Shock to IEC 60068-2-27	150 m/s ² , 11 ms, 3 shocks

Shock pulses within the specified range can be transferred to the display but do not impact the functionality of the device.

6.4 Climatic ambient conditions

6.4.1 Long-term storage

The device meets the requirements of IEC 60721-3-1 Class 1K2.

The information applies to a device that is stored in its original packaging for longer than two weeks.

6.4.2 Transport and short-term storage

The following information applies to a device that is transported in the original packaging and weather-proof packaging, and stored from some time.

The device meets the requirements according to IEC 60721-3-2 Class 2K4 with the following amendments and limitations:

Type of condition	Permitted range
Temperature	-20 ... 60 °C
Atmospheric pressure	1140 ... 660 hPa, corresponds to an elevation of -1000 to 3500 m
Relative humidity	10 ... 90%, without condensation
Pollutant concentration	SO ₂ : < 0.5 ppm; relative humidity < 60%, no condensation H ₂ S: < 0.1 ppm; relative humidity < 60%, no condensation

Note

If dewing has developed, wait until the HMI device has dried completely before switching it on.

Do not expose the HMI device to direct radiation from a heater.

6.4.3 Operating Conditions

The following information applies to a device installed according to the specifications in these compact operating instructions.

The HMI device is designed for stationary operation according to IEC 60721.

The device meets the requirements according to IEC 60721-3-3 Class 3K3 with the following amendments and limitations:

Type of condition	Mounting position	Permitted range
Temperature, Mounting in horizontal format	Vertical	0 ... 45 °C
	Inclined, maximum inclination 35°	0 ... 40 °C
Atmospheric pressure, operation elevation	1140 ... 795 hPa, corresponds to an elevation of -1000 to 2000 m	
Relative humidity	From 10 to 90%, without condensation	
Pollutant concentration	SO ₂ : < 0.5 ppm; relative humidity < 60%, no condensation H ₂ S: < 0.1 ppm; relative humidity < 60%, no condensation	

Note

The system components connected to the HMI device, the power supply for example, must also be suited to the respective operating conditions.

See also

Permitted mounting positions (Page 24)

6.5 Information on insulation tests, protection class and degree of protection

Insulation test

The insulation strength is demonstrated in the type test with the following test voltages in accordance with IEC 61131-2:

Circuit	Insulation tested with (type test)
Rated voltage U_e 24 V	707 V DC to other circuits / to ground
Ethernet connector	1500 V AC

Degree of pollution and overvoltage category

The device meets the following requirements according to IEC 61131-2:2007:

Degree of pollution	2
Overvoltage category	II

Protection class

Protection class III according to IEC 61131-2

Protection against foreign objects and water

The device meets the requirements according to IEC 60529 and UL50.

Device side	Degree of protection
All-round	<ul style="list-style-type: none"> IP65 according to IEC 60529 Enclosure Type 4X/12 (indoor use only) according to UL50

The degree of protection can only be guaranteed if the seals are completely flush at the mechanical interfaces and at the terminal compartment, and the associated covers are closed.

6.6 Dimension drawings

6.6.1 TP1200 Comfort PRO

TP1200 Comfort PRO, suitable for pedestal and extension components

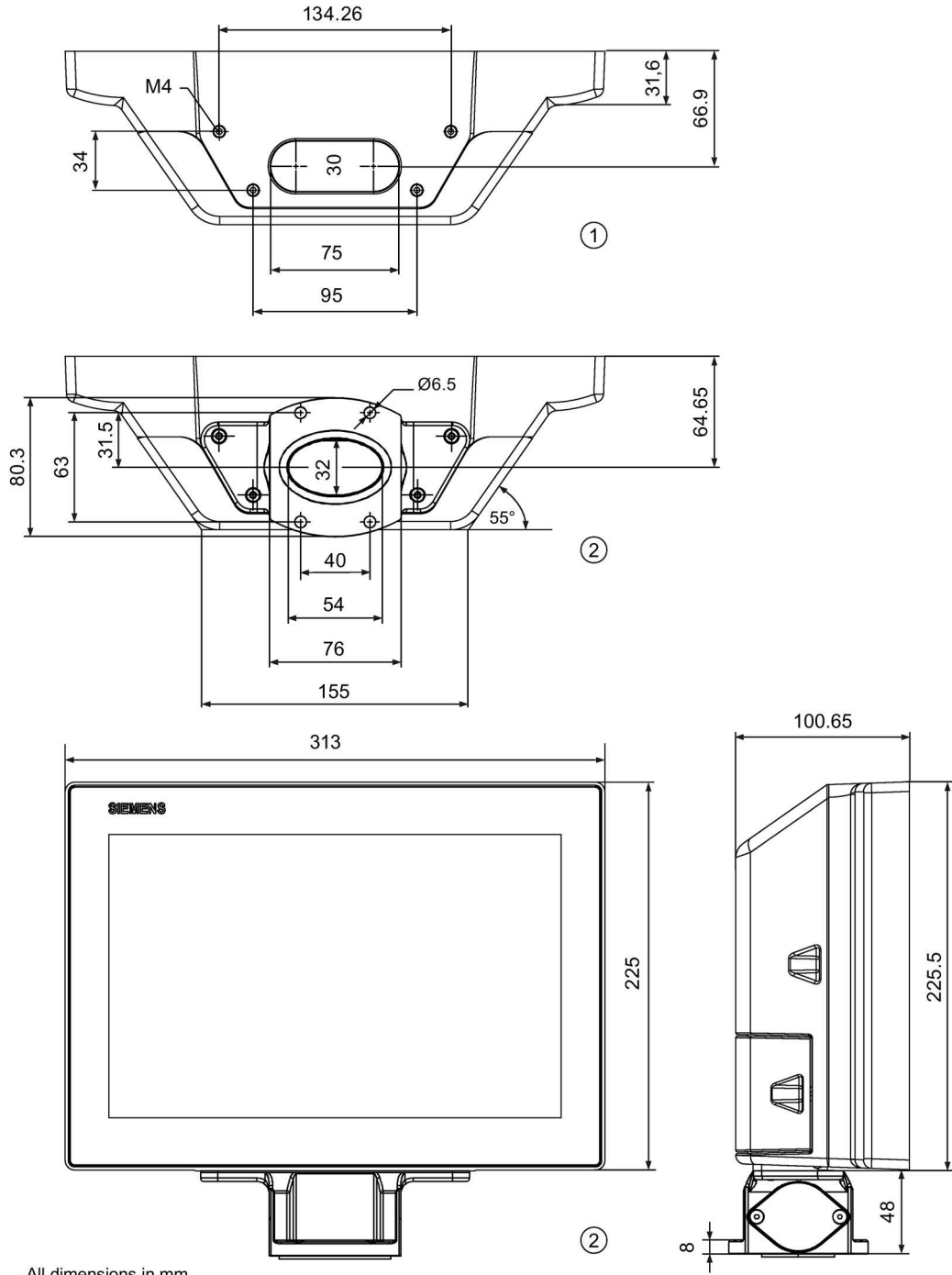

All dimensions in mm.

- ① Without base adapter
- ② With base adapter

TP1200 Comfort PRO, suitable for support arm

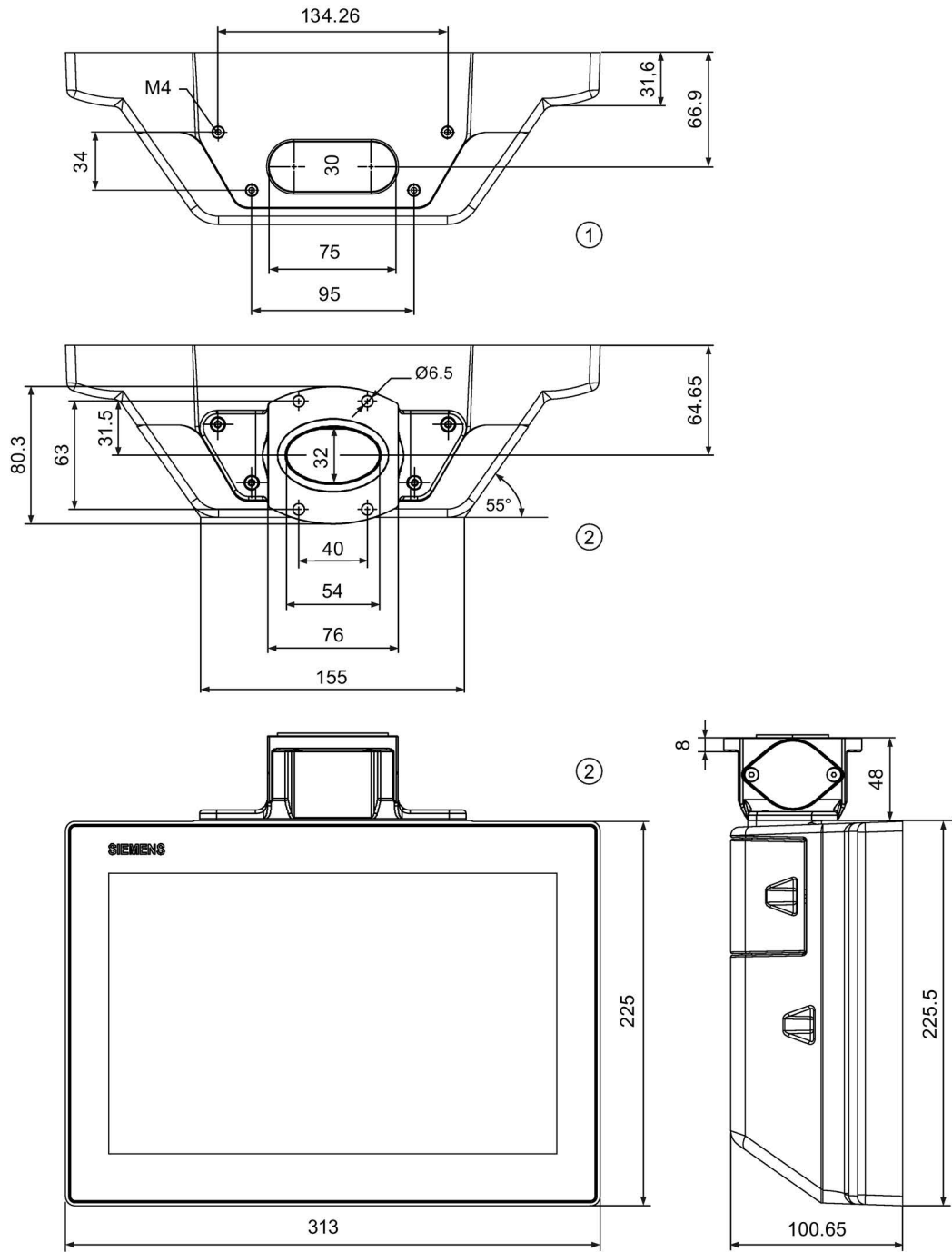

All dimensions in mm.

- ① Without base adapter
- ② With base adapter

TP1200 Comfort PRO, suitable for support arm and extension components

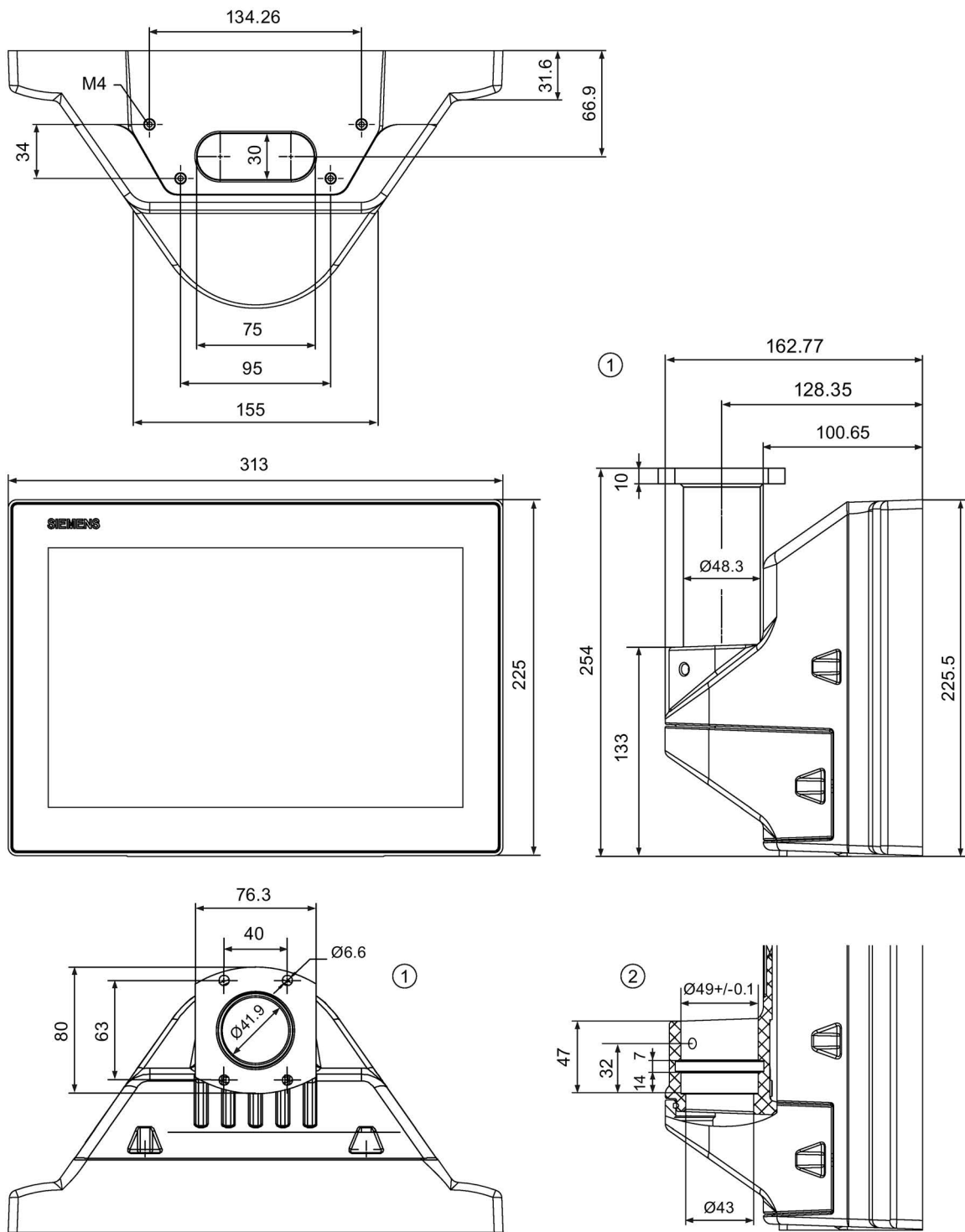

All dimensions in mm.

- ① With flange mount
- ② Without flange mount

6.6.2 TP1500 Comfort PRO

TP1500 Comfort PRO, suitable for pedestal and extension components

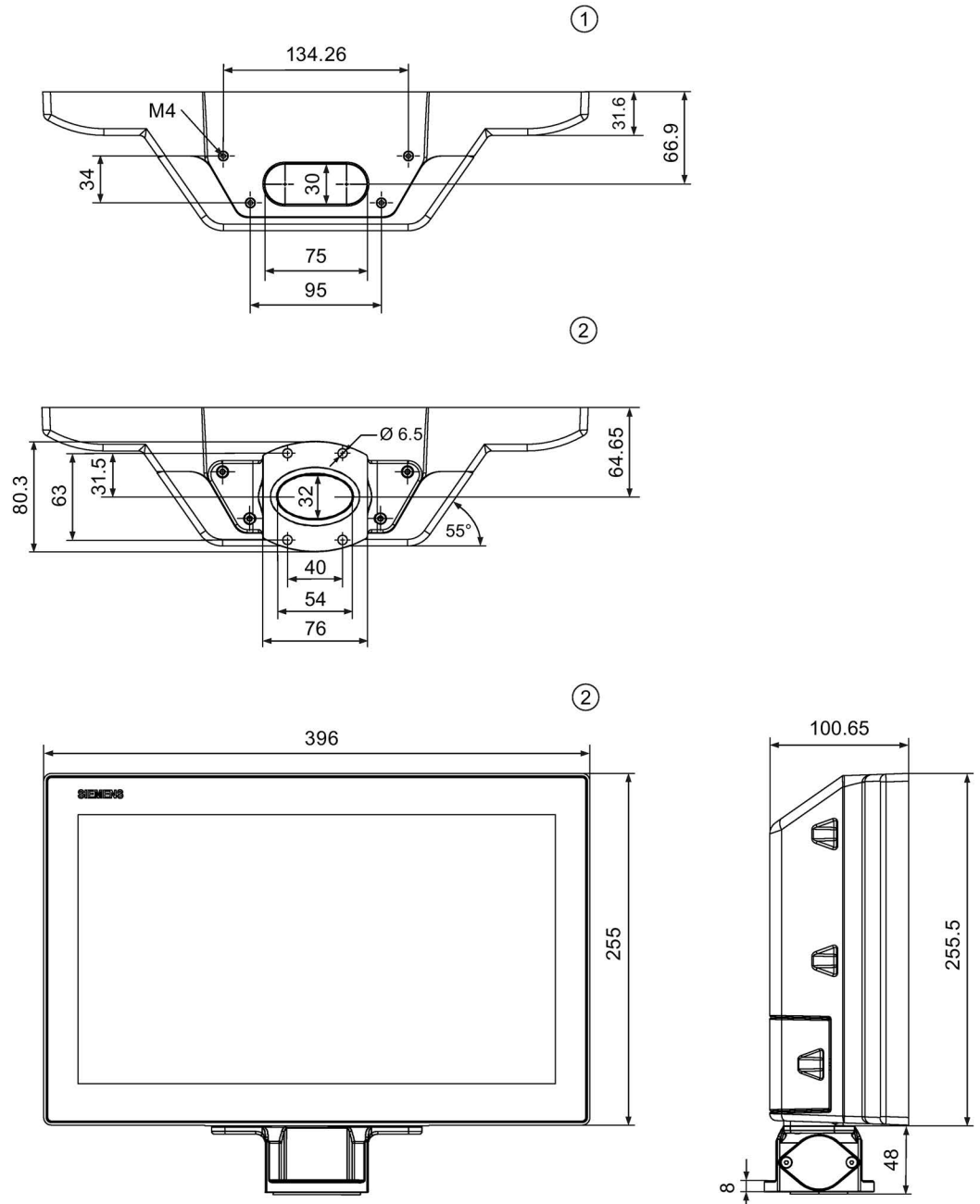

All dimensions in mm.

- ① Without base adapter
- ② With base adapter

TP1500 Comfort PRO, suitable for support arm

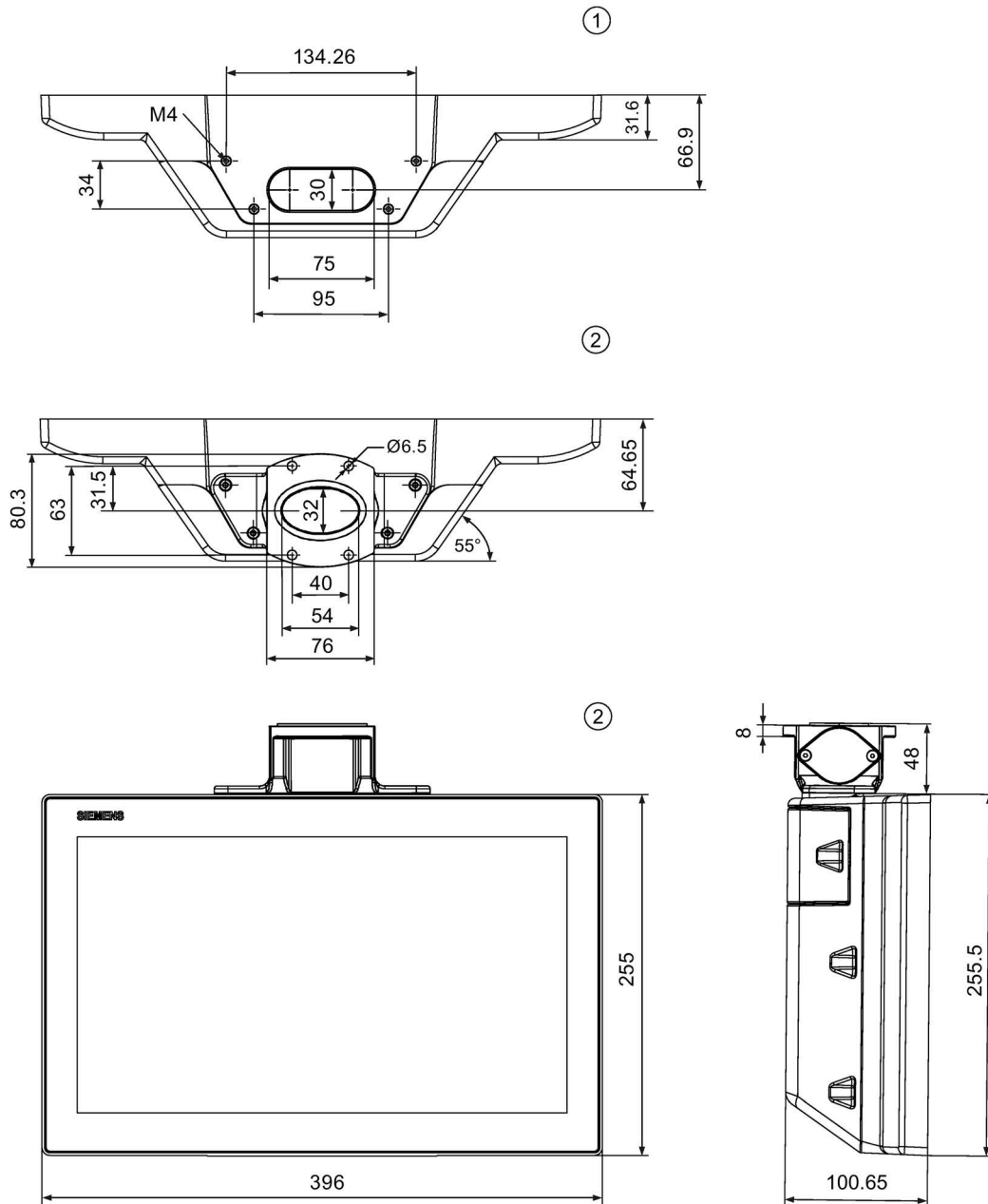

All dimensions in mm.

- ① Without base adapter
- ② With base adapter

TP1500 Comfort PRO, suitable for support arm and extension components

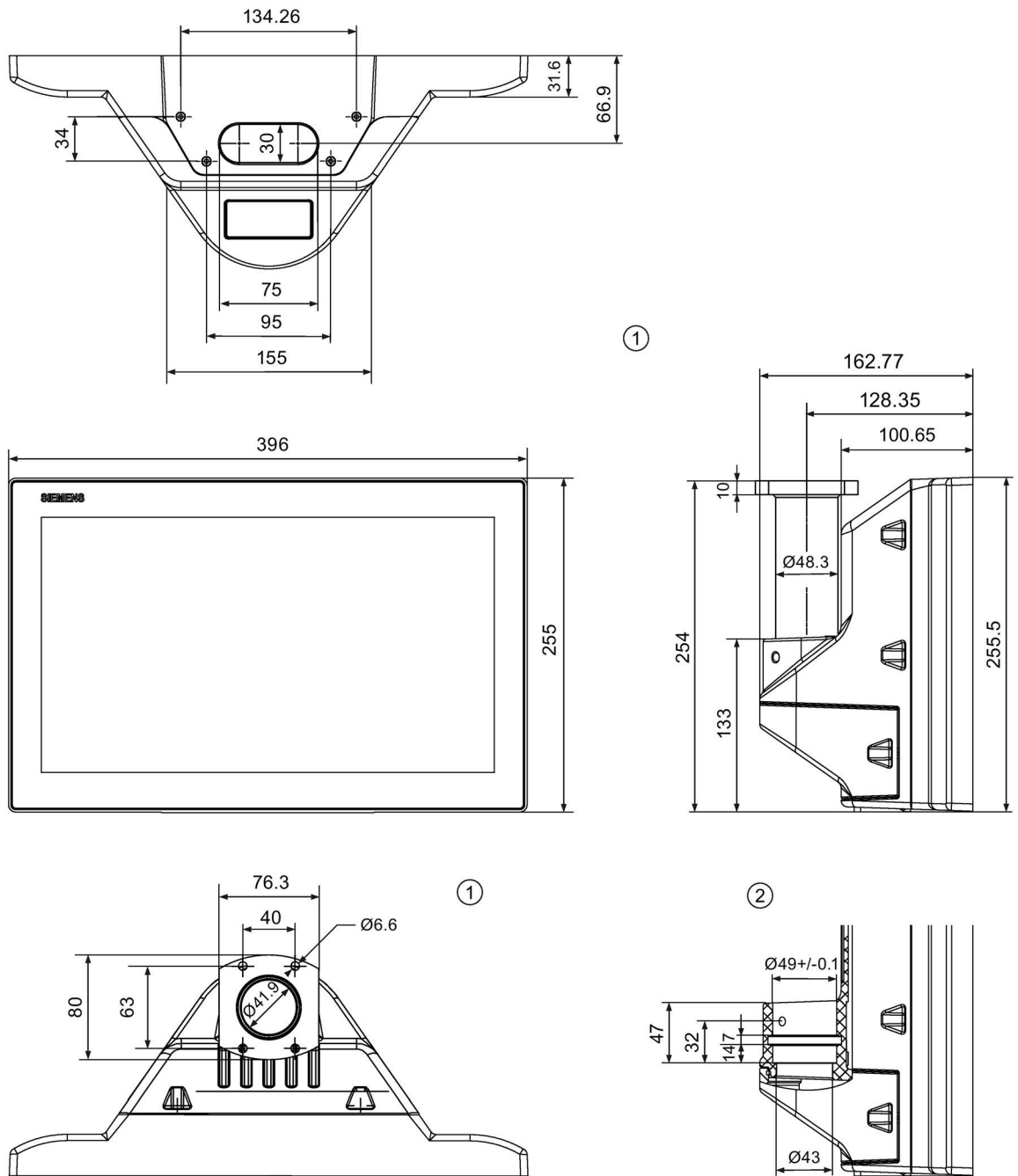

All dimensions in mm.

- ① With flange mount
- ② Without flange mount

6.6.3 TP1900 Comfort PRO

TP1900 Comfort PRO, suitable for pedestal and extension components

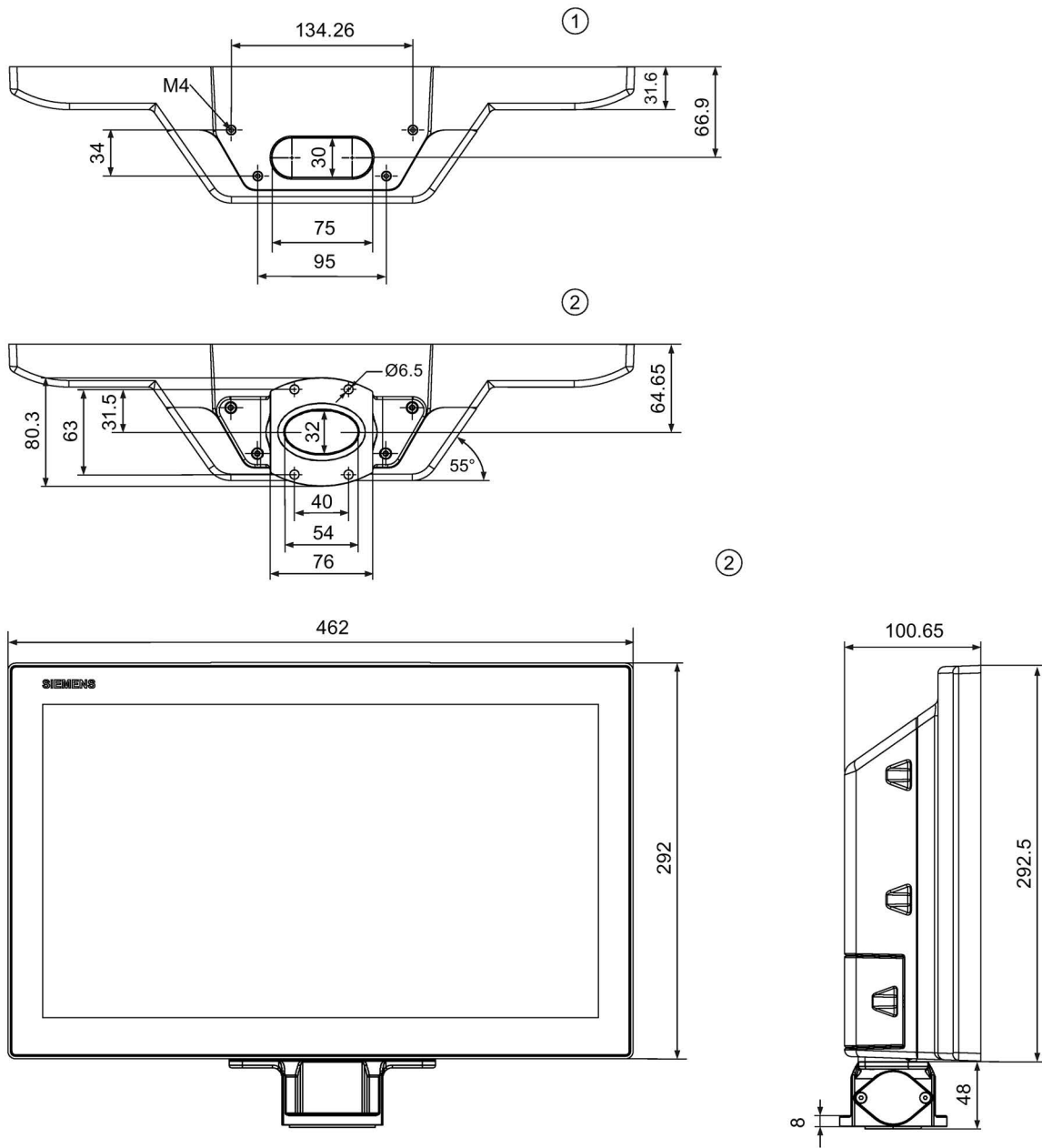

All dimensions in mm.

- ① Without base adapter
- ② With base adapter

TP1900 Comfort PRO, suitable for support arm

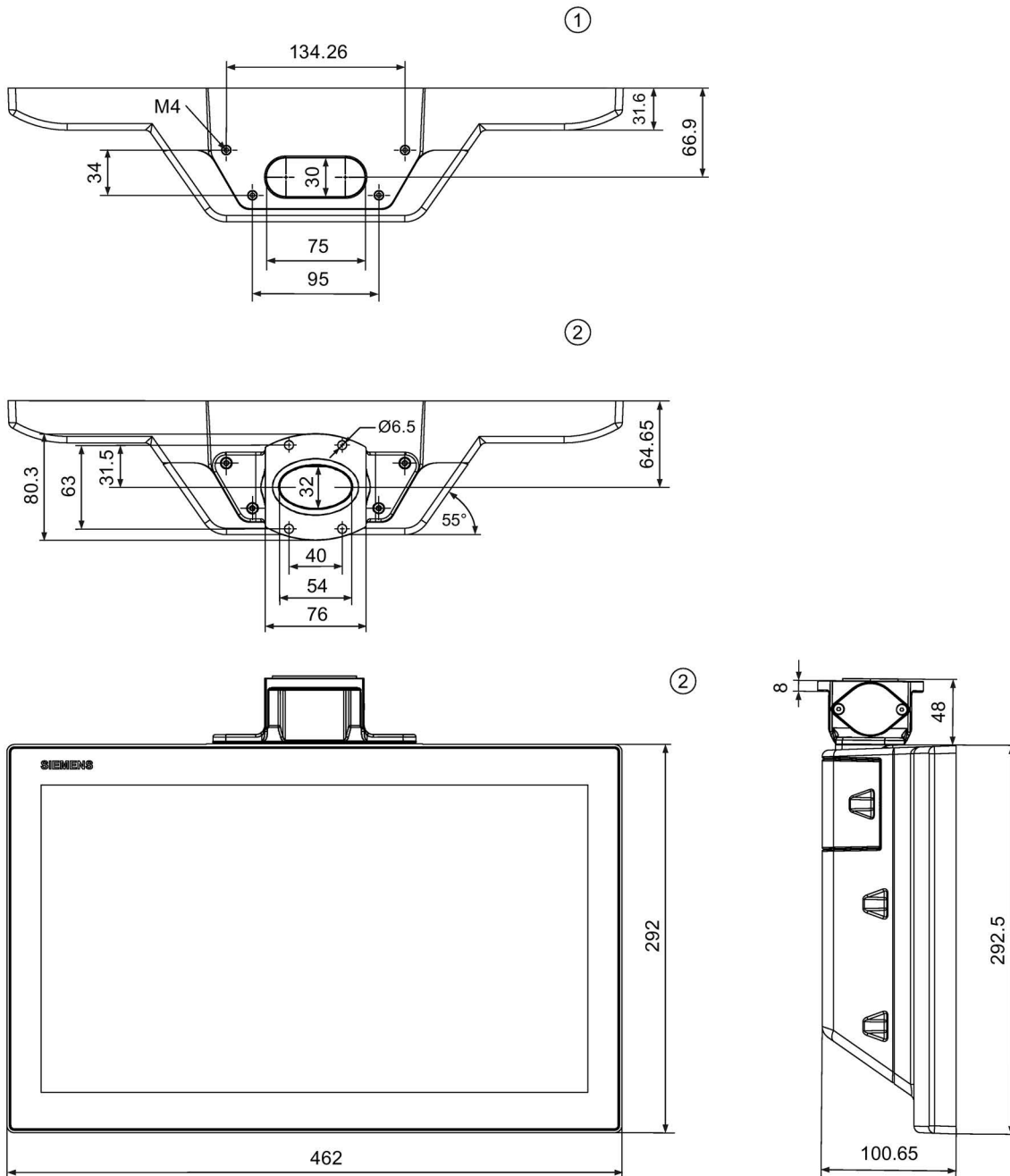

All dimensions in mm.

- ① Without base adapter
- ② With base adapter

TP1900 Comfort PRO, suitable for support arm and extension components

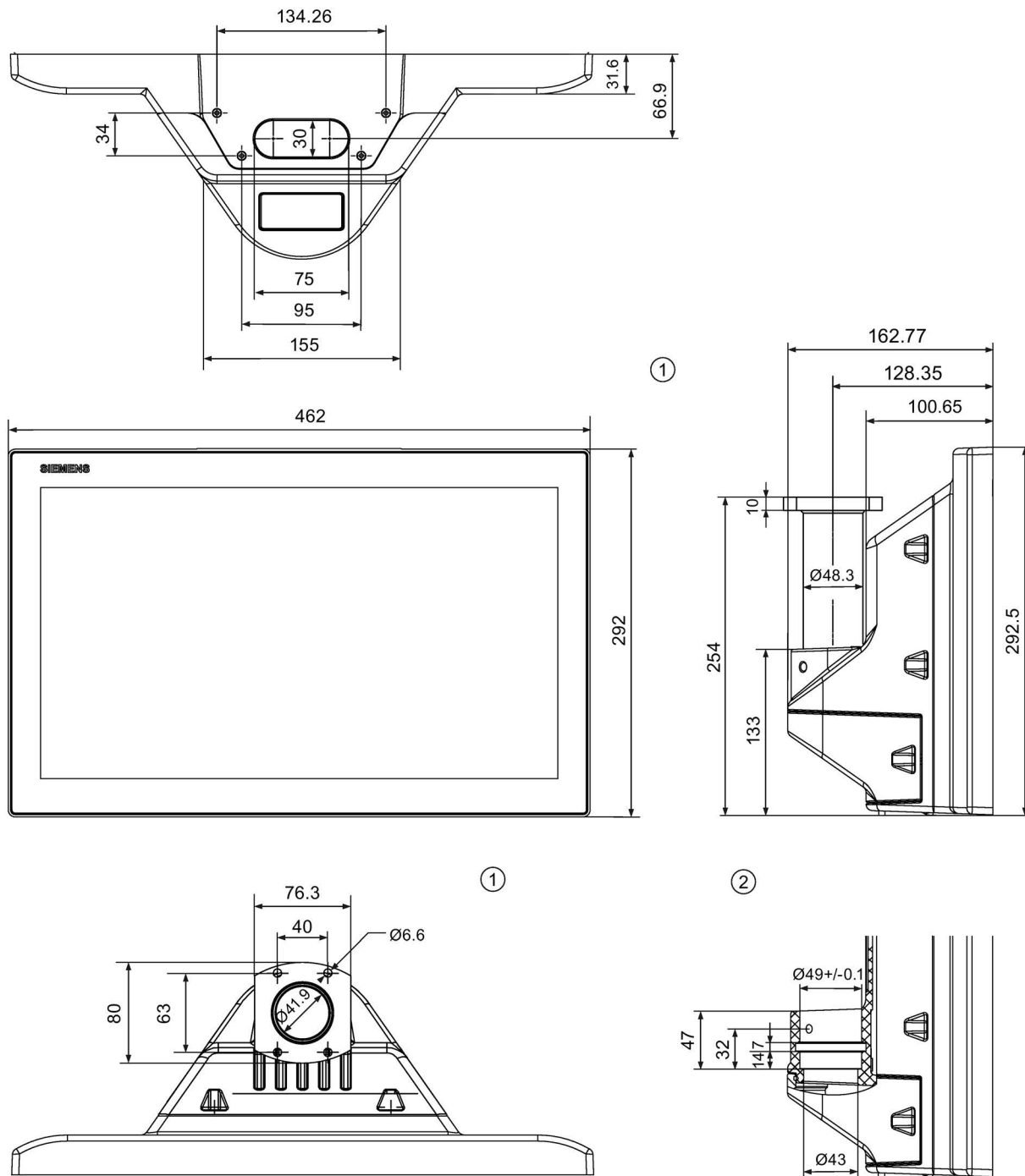

All dimensions in mm.

- ① With flange mount
- ② Without flange mount

6.6.4 TP2200 Comfort PRO

TP2200 Comfort PRO, suitable for pedestal and extension components

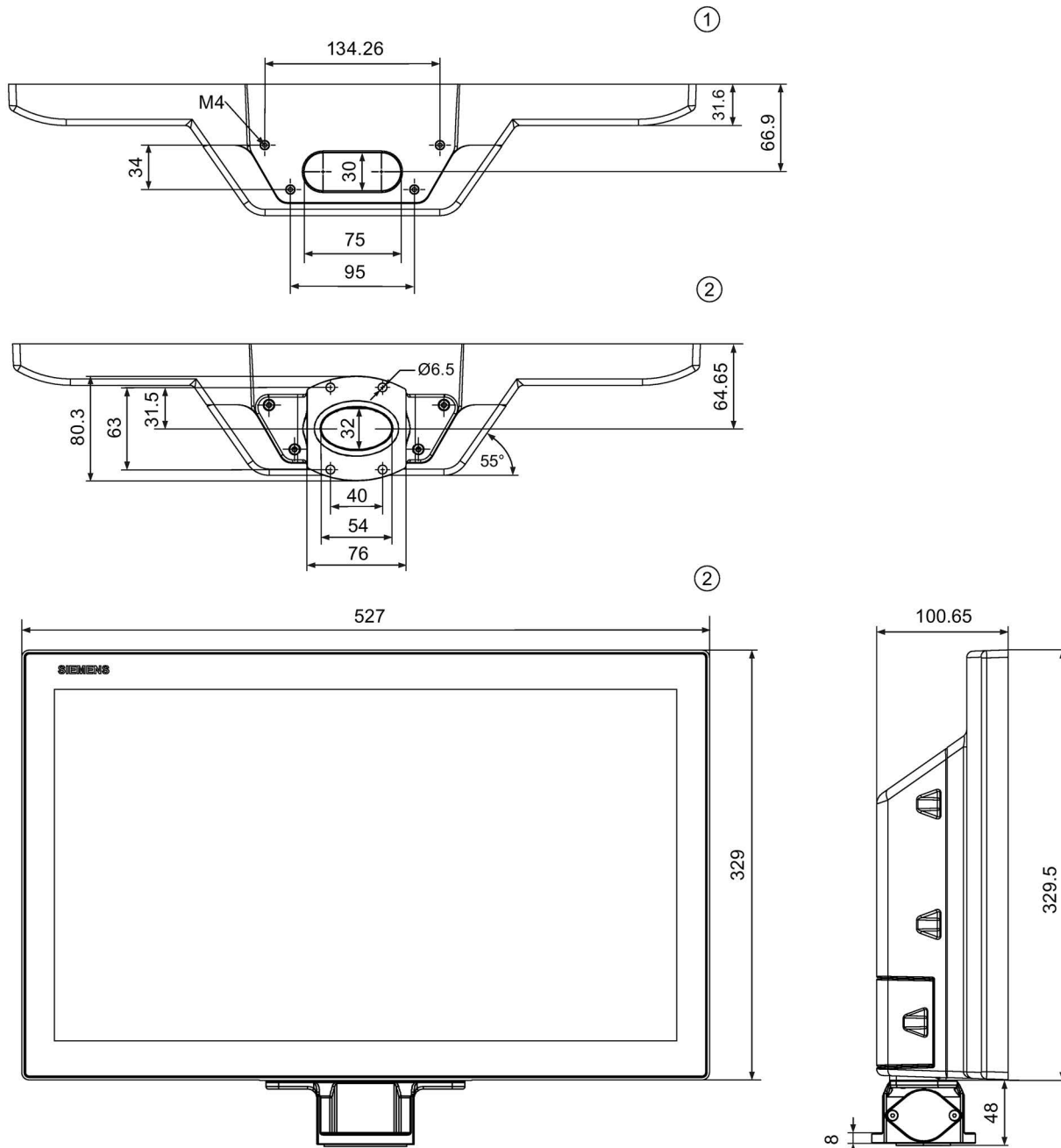

All dimensions in mm.

- ① Without base adapter
- ② With base adapter

TP2200 Comfort PRO, suitable for support arm

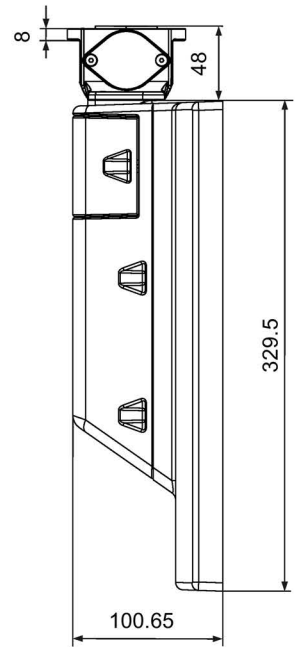
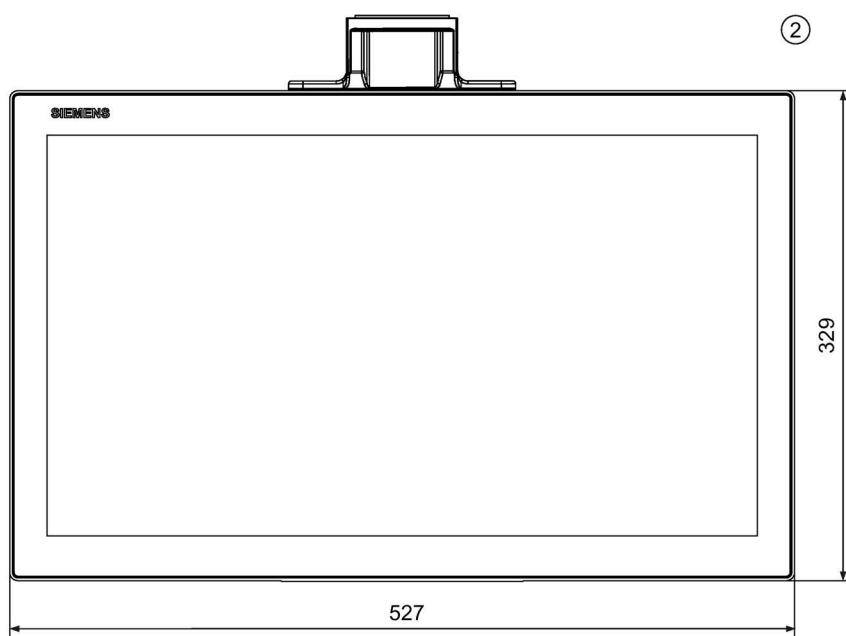
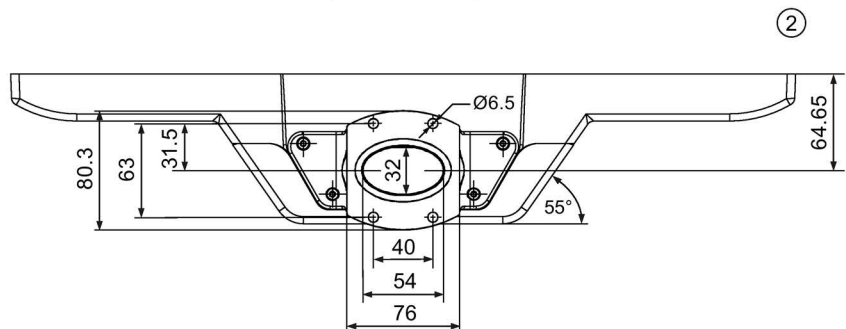
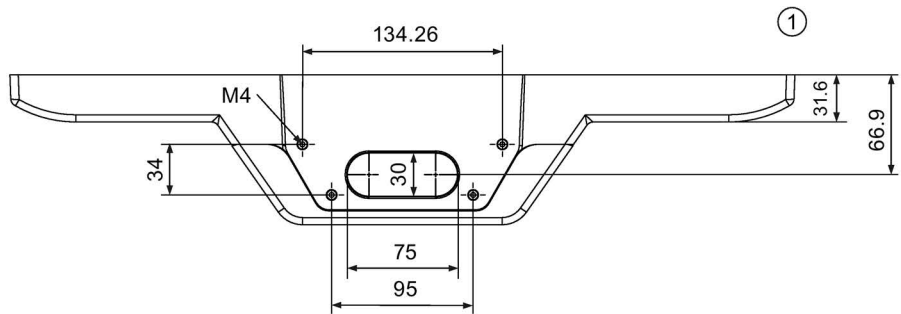

All dimensions in mm.

- ① Without base adapter
- ② With base adapter

TP2200 Comfort PRO, suitable for support arm and extension components

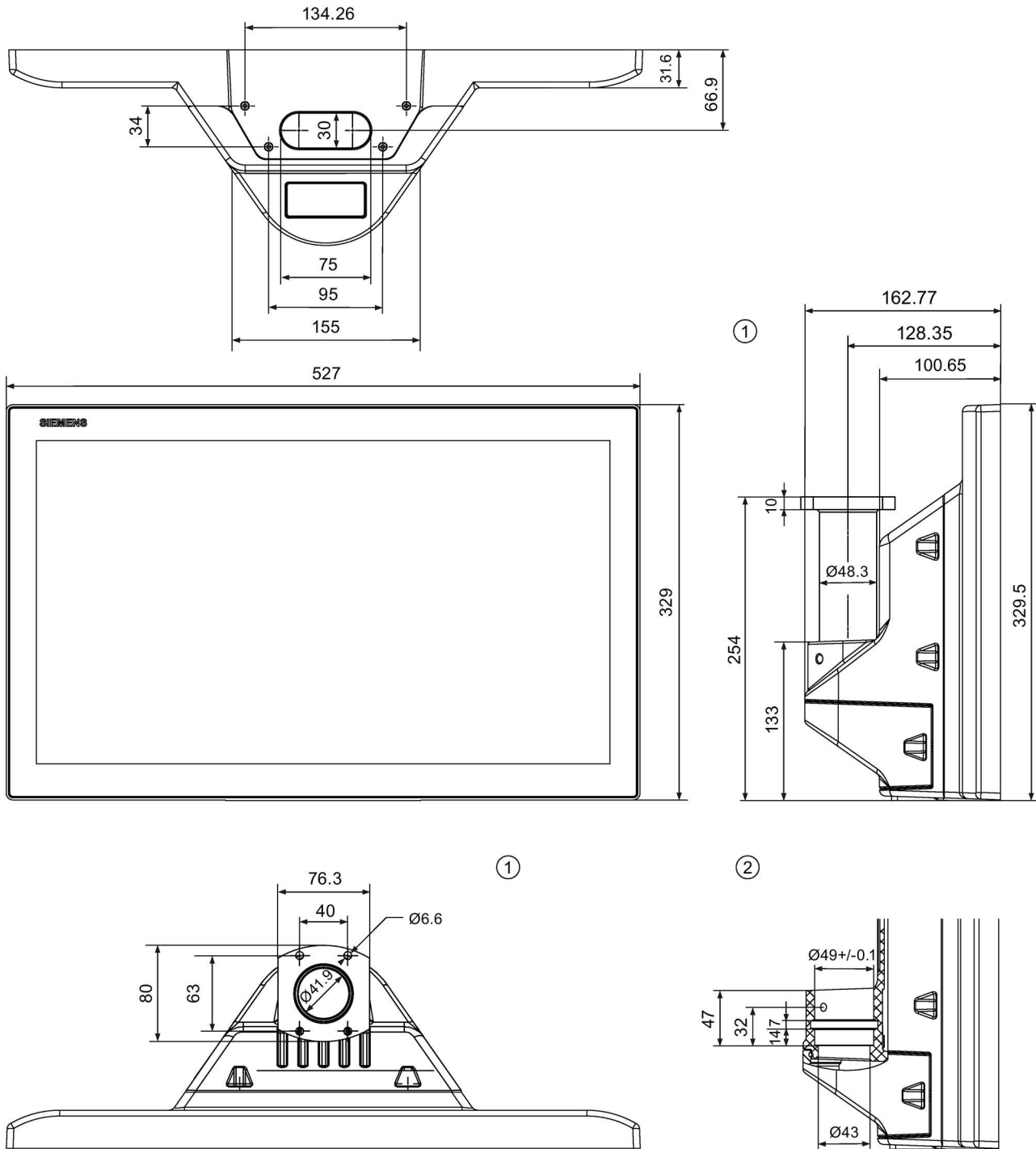

All dimensions in mm.

- ① With flange mount
- ② Without flange mount

6.7 Specifications

Weight of the PRO PRO devices suitable for pedestal and extension components / support arm

	TP1200 Comfort PRO	TP1500 Comfort PRO	TP1900 Comfort PRO	TP2200 Comfort PRO
Weight without packaging	4.5 kg	6.3 kg	7.4 kg	8.5 kg

Weight of the PRO devices suitable for support arm and extension components

	TP1200 Comfort PRO	TP1500 Comfort PRO	TP1900 Comfort PRO	TP2200 Comfort PRO
Weight without packaging	4.9 kg	6.2 kg	7.2 kg	8.1 kg

Display

	TP1200 Comfort PRO	TP1500 Comfort PRO	TP1900 Comfort PRO	TP2200 Comfort PRO
Type	LCD TFT			
Active display area	12.1" 261.1 mm x 163.2 mm	15.6" 344.2 x 193.5 mm	18.5" 409.8 x 230.4 mm	21.5" 495.6 x 292.2 mm
Resolution	1280 x 800 pixels	1366 x 768 pixels	1366 x 768 pixels	1920 x 1080 pixels
Possible colors	Up to 16 million			
Brightness control	Manual/automatic, value range 0 to 100 ¹ , 0 = backlighting off			
Backlighting	LED, dimmable			
Half Brightness Life Time (MTBF ²)	80000 h	50000 h	50000 h	30000 h
Pixel error class in accordance with ISO 9241-307	I			

¹ Via WinCC: Complete range, via Control Panel: Manual ("Low limit" to 100) or automatic (0 to 100). The factory setting for "Low limit" is a fixed minimum value.

² MTBF: Operating hours after which the maximum brightness is reduced by half compared to the original value. MTBF is increased by using the integrated dimming function, for example time-controlled via screen saver or centrally via PROFenergy.

Input device

	TP1200 Comfort PRO	TP1500 Comfort PRO	TP1900 Comfort PRO	TP2200 Comfort PRO
Touch screen	Yes, projective capacitive			

Memory

	TP1200 Comfort PRO	TP1500 Comfort PRO	TP1900 Comfort PRO	TP2200 Comfort PRO
Usable memory for application data	12 MB	24 MB		
Usable memory for recipe data ¹	2 MB	4 MB		
Additional memory for options	12 MB	24 MB		
Data memory card ²	1 x MMC/SD combination slot			
System memory card ²	1 x SD slot			

¹ Can be extended via memory card

² Memory cards are available as SIMATIC HMI accessories

Interfaces

	TP1200 Comfort PRO	TP1500 Comfort PRO	TP1900 Comfort PRO	TP2200 Comfort PRO
1 x RS 422/485 (PROFIBUS)	Max. 12 Mbps, applies to DP operations			
Ethernet (PROFINET)	2 x RJ45 10/100 Mbps ¹			
Ethernet (PROFINET)	1 x RJ45 10/100/1000 Mbps			
Audio	Line Out			
USB 2.0	2 x Host ²			

¹ With integrated switch (one IP address only)

² USB type A; maximum load 500 mA

Power supply

	TP1200 Comfort PRO	TP1500 Comfort PRO	TP1900 Comfort PRO	TP2200 Comfort PRO
Rated voltage	24 V DC			
Permitted voltage range	+19.2 V to +28.8 V			
Rated current	1.5 A	1.5 A	1.5 A	1.8 A
Rated current, load-dependent	1.2 ... 1.7 A	1.2 ... 1.8 A	1.2 ... 1.8 A	1.5 ... 2.2 A
Inrush current I _{2t}	0.5 A ² s			
Power consumption ¹	36 W	36 W	36 W	44 W
Maximum permitted transient	35 V (500 ms)			
Minimum time between two transients	50 s			
Internal protection	Yes			

¹ The power loss generally corresponds to the specified value for power consumption.

Miscellaneous

	TP1200 Comfort PRO	TP1500 Comfort PRO	TP1900 Comfort PRO	TP2200 Comfort PRO
Buffered real-time clock ¹	Yes			
Audio reproduction	Integrated or external via Line OUT			
Magnetic field intensity	50/60 Hz; 100 A/m RMS			

¹ Battery backup typically 6 weeks

6.8 Interface description

The specifications in the section "Interface description" of the "Comfort Panels" operating instructions apply.

6.9 Scope of functions with WinCC

The tables below show the objects which can be integrated in a project for an HMI device.

Note

The specified values are maximum values of the individual objects. Simultaneous use of multiple objects with their maximum value can lead to problems in the active project.

Alarms

Object	Specification	TP1200 Comfort PRO	TP1500/1900/2200 Comfort PRO
Alarms	Number of discrete alarms	4000	6000
	Number of analog alarms	200	
	Alarm length	80 characters	
	Number of tags / process values in an alarm	Max. 8	
	Number of alarm classes	32	
	Display	Alarm window, alarm view	
	Acknowledge error alarm individually	Yes	
	Edit alarm	Yes	
	Alarm indicator	Yes	
ALARM_S	Display S7 alarms	Yes	
Alarm buffer, retentive	Alarm buffer capacity	1024	
	Simultaneously queued alarm events	500	
	View alarm	Yes	
	Delete alarm buffer	Yes	
	Print alarms line by line	Yes	

Note

Read the notes on using the internal memory

If too many alarms are written to the alarm buffer in short time intervals, the life of the internal memory and thus the service life of the HMI device will be reduced.

When configuring alarms, read the notes on the internal memory in the section "Memory concept (Page 37)".

Tags, values and lists

Object	Specification	TP1200 Comfort PRO	TP1500/1900/2200 Comfort PRO
Tags	Number	2048	4096
Limit value monitoring	Input/output	Yes	
Linear scaling	Input/output	Yes	
Text lists	Number	500 ¹	
Graphics lists	Number	500 ¹	

¹ The maximum total of text and graphics lists is 500.

Screens

Object	Specification	TP1200 Comfort PRO	TP1500/1900/2200 Comfort PRO
Screens	Number	500	750
	Objects per screen	400	600
	Tags per screen	400	600
	Complex objects per screen (for example, bars)	20	40
	Template	Yes	

Recipes

Object	Specification	TP1200 Comfort PRO	TP1500/1900/2200 Comfort PRO
Recipes	Number	300	500
	Data records per recipe	500	1000
	Entries per data record	1000	2000
	Recipe memory	2 MB	4 MB
	Storage location ¹	<ul style="list-style-type: none"> • Memory card (MMC/SD) • USB storage medium • Network drive 	

¹ The number of recipe data records may be restricted by the capacity of the storage medium.

Logs

Note

The HMI devices are suitable for the logging of relatively small volumes of data.

Manage the data in several adjacent logs in a segmented circular log. The use of a large circular log has a negative effect on performance.

Object	Specification	TP1200 Comfort PRO	TP1500/1900/2200 Comfort PRO
Logs	Number of logs	50	
	Number of partial logs in a segmented circular log	400	
	Entries per log ¹	20000	50000
	Filing format	CSV with ANSI character set, RDB, TXT	
	Storage location	<ul style="list-style-type: none"> • Memory card • USB storage medium • Network drive 	

¹ The number of entries in the log may be restricted by the capacity of the storage medium.

Read the notes on using logs in the section "Memory concept (Page 37)".

Safety

Object	Specification	TP1200 Comfort PRO	TP1500/1900/2200 Comfort PRO
User view	Number of user groups	50	
	Number of users	50	
	Number of authorizations / user permissions	32	

Info texts

Object	Specification	TP1200 Comfort PRO	TP1500/1900/2200 Comfort PRO
Info texts	Length (no. of characters)	500 (depending on font)	
	For alarms	Yes	
	For screens	Yes	
	For screen objects (e.g. I/O field, switch, button, invisible button)	Yes	

Additional functions

Object	Specification	TP1200 Comfort PRO	TP1500/1900/2200 Comfort PRO
Screen settings	Brightness setting	Yes	
Language change	Number of languages per project	32	
VB Script	User-specific extension of the functionality	Yes	
	Number of scripts	100	200
Graphic objects	Vector and pixel graphics	Yes	
Trends	Number	300	400
Scheduler	Number of tasks	48	
Text objects	Number	40000	
Direct keys	PROFIBUS DP direct keys	Yes	
	PROFINET IO direct keys	Yes	

A.1 Service and support

You can find additional information and support for the products described on the Internet at the following addresses:

- Technical support (<https://support.industry.siemens.com>)
- Support request form (<http://www.siemens.com/automation/support-request>)
- After Sales Information System SIMATIC IPC/PG (<http://www.siemens.com/asis>)
- SIMATIC Documentation Collection (<http://www.siemens.com/simatic-tech-doku-portal>)
- Your local representative
(<http://www.automation.siemens.com/mcms/aspa-db/en/Pages/default.aspx>)
- Training center (<http://sitrain.automation.siemens.com/sitrainworld/?AppLang=en>)
- Industry Mall (<https://mall.industry.siemens.com>)

When contacting your local representative or Technical Support, please have the following information at hand:

- MLFB of the device
- BIOS version for industrial PC or image version of the device
- Other installed hardware
- Other installed software

Tools & downloads

Please check regularly if updates and hotfixes are available for download to your device. The download area is available on the Internet at the following link:

After Sales Information System SIMATIC IPC/PG (<http://www.siemens.com/asis>)

A.2 Troubleshooting and system alarms

The specifications in "Comfort Panels" operating instructions apply.

Index

A

Alarm buffer, 60
ALARM_S, 60
Alarms, 60
Approvals, 42

B

Base adapter, 15
Brightness setting, 63

C

Compact Operating Instructions
 Validity, 3
Convention
 Term, 4

D

Degree of pollution, 45
Degree of protection, 45
Dimension drawings
 TP1200 Comfort PRO, 46
 TP1500 Comfort PRO, 49
 TP1900 Comfort PRO, 52
 TP2200 Comfort PRO, 55
Direct keys, 63
Display
 HMI devices, 58
Documentation
 Enclosed, 23

E

Earth connection, 35
ESD, 20
Extension Unit, 17

F

Figures, 4
Flange mount, 16

H

HMI device
 Installing, 29, 31
 Technical specifications, 58
HMI devices
 Input device, 58
 Interfaces, 59
 Memory, 59
HMI devices
 Display, 58
 Weight, 58
HMI I/O components, 18

I

Info texts, 62
Input device
 HMI devices, 58
Input help, 18
Installing
 HMI device, 29, 31
Instructions
 General, 22
Insulation test, 45
Interfaces
 HMI devices, 59

L

Language change, 63
Lists, 61
Log
 Format, 62
Logs, 62

M

Memory
 HMI devices, 59
Memory card, 18
Mounting position
 PRO device, 24

N

Naming conventions, 4

O

Operation

capacitive single-touch screen, 35

Overtoltage category, 45

P

Power supply

HMI devices, 59

PRO device, pedestal and extension components

Views, 11

PRO device, support arm

Views, 10

PRO device, support arm and extension components

Views, 13

PROFIBUS connector, 18

Protection against ingress of solid foreign bodies, 45

Protection against water, 45

Protection class, 45

R

Radiation, 20

High-frequency radiation, 20

Radio interference, 22

Recipes, 61

S

Safety instruction

Operation indoors, 21

Storage, 44

Transportation, 44

Scheduler, 63

Screens, 61

Storage media, 18

Support arm system, 15

Adapter set VESA 100, 15

Adapter set VESA 75, 15

BERNSTEIN adaptation, 15

RITTAL adapter, 15

ROLEC adapter, 15

T

Tags, 61

Technical specifications

Display, 58

HMI devices, 58

Input device, 58

Interfaces, 59

Memory, 59

Power supply, 59

Text objects, 63

TP1200 Comfort PRO

Dimension drawings, 46

TP1500 Comfort PRO

Dimension drawings, 49

TP1900 Comfort PRO

Dimension drawings, 52

TP2200 Comfort PRO

Dimension drawings, 55

Transport damage, 23

Trends, 63

U

USB stick, 18

Use

in mixed-use zone, 22

In residential areas, 22

Industrial, 22

With additional measures, 22

User view, 62

V

VB Script, 63

W

Weight

HMI devices, 58