

SIMATIC

ET 200SP Product information on the documentation of the ET 200SP distributed I/O system

Product Information

Preface

Module overview of
ET 200SP

1



Supplements to ET 200SP
documentation

2

Legal information

Warning notice system

This manual contains notices you have to observe in order to ensure your personal safety, as well as to prevent damage to property. The notices referring to your personal safety are highlighted in the manual by a safety alert symbol, notices referring only to property damage have no safety alert symbol. These notices shown below are graded according to the degree of danger.

| |
|--------------------------------------------------------------------------------------------------------|
|  DANGER |
| indicates that death or severe personal injury will result if proper precautions are not taken. |
|  WARNING |
| indicates that death or severe personal injury may result if proper precautions are not taken. |
|  CAUTION |
| indicates that minor personal injury can result if proper precautions are not taken. |
| NOTICE |
| indicates that property damage can result if proper precautions are not taken. |

If more than one degree of danger is present, the warning notice representing the highest degree of danger will be used. A notice warning of injury to persons with a safety alert symbol may also include a warning relating to property damage.

Qualified Personnel

The product/system described in this documentation may be operated only by **personnel qualified** for the specific task in accordance with the relevant documentation, in particular its warning notices and safety instructions. Qualified personnel are those who, based on their training and experience, are capable of identifying risks and avoiding potential hazards when working with these products/systems.

Proper use of Siemens products

Note the following:

| |
|------------------------------------------------------------------------------------------------------------------------------------------------------------------------------------------------------------------------------------------------------------------------------------------------------------------------------------------------------------------------------------------------------------------------------------------------------------------------------------------------------------------------------------------------------|
|  WARNING |
| Siemens products may only be used for the applications described in the catalog and in the relevant technical documentation. If products and components from other manufacturers are used, these must be recommended or approved by Siemens. Proper transport, storage, installation, assembly, commissioning, operation and maintenance are required to ensure that the products operate safely and without any problems. The permissible ambient conditions must be complied with. The information in the relevant documentation must be observed. |

Trademarks

All names identified by ® are registered trademarks of Siemens AG. The remaining trademarks in this publication may be trademarks whose use by third parties for their own purposes could violate the rights of the owner.

Disclaimer of Liability

We have reviewed the contents of this publication to ensure consistency with the hardware and software described. Since variance cannot be precluded entirely, we cannot guarantee full consistency. However, the information in this publication is reviewed regularly and any necessary corrections are included in subsequent editions.

Preface

Validity

This product information supplements the documentation for the ET 200SP and takes precedence over our system manuals, function manuals and product manuals.

Security information

Siemens provides products and solutions with industrial security functions that support the secure operation of plants, systems, machines and networks.

In order to protect plants, systems, machines and networks against cyber threats, it is necessary to implement – and continuously maintain – a holistic, state-of-the-art industrial security concept. Siemens' products and solutions only form one element of such a concept.

Customer is responsible to prevent unauthorized access to its plants, systems, machines and networks. Systems, machines and components should only be connected to the enterprise network or the internet if and to the extent necessary and with appropriate security measures (e.g. use of firewalls and network segmentation) in place.

Additionally, Siemens' guidance on appropriate security measures should be taken into account. For more information about industrial security, please visit (<http://www.siemens.com/industrialsecurity>).

Siemens' products and solutions undergo continuous development to make them more secure. Siemens strongly recommends to apply product updates as soon as available and to always use the latest product versions. Use of product versions that are no longer supported, and failure to apply latest updates may increase customer's exposure to cyber threats.

To stay informed about product updates, subscribe to the Siemens Industrial Security RSS Feed under (<http://www.siemens.com/industrialsecurity>).

Table of contents

| | | |
|----------|------------------------------------------------------------------------|-----------|
| | Preface | 3 |
| 1 | Module overview of ET 200SP | 5 |
| 1.1 | Possible combinations of BaseUnits and I/O modules | 5 |
| 1.2 | CPUs..... | 13 |
| 1.3 | Interface modules..... | 14 |
| 1.4 | BaseUnits..... | 16 |
| 1.5 | I/O modules..... | 18 |
| 1.6 | Motor starters..... | 20 |
| 1.7 | Accessories..... | 21 |
| 2 | Supplements to ET 200SP documentation | 26 |
| 2.1 | Using the SIMATIC ET 200SP over 2000 m above sea level. | 26 |
| 2.2 | System manual | 28 |
| 2.3 | BaseUnits manual..... | 28 |
| 2.3.1 | Special consideration for BaseUnits with functional versions < 04..... | 28 |
| 2.3.2 | Terminal labeling of the PotDis-TB | 29 |
| 2.4 | CPU manuals..... | 30 |
| 2.5 | Interface module manuals..... | 31 |
| 2.6 | I/O module manuals..... | 35 |
| 2.6.1 | Digital module device manuals | 37 |
| 2.6.2 | Analog module device manuals..... | 42 |
| 2.6.3 | Communications module manuals..... | 46 |
| 2.6.4 | Device manuals Technology modules | 46 |
| 2.7 | Function manuals..... | 46 |

Module overview of ET 200SP

1.1 Possible combinations of BaseUnits and I/O modules

Contents



This product information includes amendments and corrections to the documentation of the ET 200SP Distributed I/O System

(<https://support.industry.siemens.com/cs/ww/en/view/109742709>).

Which I/O modules / motor starters fit on a BaseUnit?

The following table provides an overview of the I/O modules / motor starters that fit on the corresponding compatible BaseUnits:

Table 1- 1 Possible combinations of BaseUnits and I/O modules

| I/O module | BaseUnit BU15- | | BaseUnit BU20- | | | | | | | Color-coded label for process terminals |
|----------------------------|----------------|------------|----------------|------------|------------|------------|------------|------------|------------|--------------------------------------------------------------------------------------------|
| | BU type A0 | BU type A1 | BU type B0 | BU type B1 | BU type C0 | BU type C1 | BU type D0 | BU type F0 | BU type U0 | |
| P16+A10+2D | P16+A0+12D | P12+A4+0B | P12+A0+4B | P6+A2+4D | P6+A2+4B | P12+A0+0B | P8+A4+0B | P16+A0+2D | P16+A0+2B | |
| P16+A0+2D | P16+A0+2D/T | | | | | | | | | |
| P16+A10+2B | P16+A0+12B | | | | | | | | | |
| P16+A0+2B | P16+A0+2B/T | | | | | | | | | |
| P16+A0+2B | P16+A0+2B/T | | | | | | | | | |
| Digital I/O modules | | | | | | | | | | |
| DI 16x24VDC ST | ✓ | | | | | | | | | CC00  |
| DI 8x24VDC ST | ✓ | | | | | | | | | CC01  |

1.1 Possible combinations of BaseUnits and I/O modules

| I/O module | BaseUnit BU15- | | BaseUnit BU20- | | | | | | | Color-coded label for process terminals | | |
|----------------------|----------------------------------------------------|--------------------------------------------------------------|----------------|------------|------------|------------|------------|------------|------------------------|-----------------------------------------|------|--|
| | BU type A0 | BU type A1 | BU type B0 | BU type B1 | BU type C0 | BU type C1 | BU type D0 | BU type F0 | BU type U0 | | | |
| | P16+A10+2D P16+A0+2D P16+A10+2B P16+A0+2B | P16+A0+12D /T P16+A0+2D/T P16+A0+12B /T P16+A0+2B/T | P12+A4+0B | P12+A0+4B | P6+A2+4D | P6+A2+4B | P12+A0+0B | P8+A4+0B | P16+A0+2D P16+A0+2B | | | |
| DI 8x24VDC HF | ✓ | | | | | | | | | | CC01 | |
| DI 8x24VDC HS | ✓ | | | | | | | | | | CC01 | |
| DI 8x24VDC BA | ✓ | | | | | | | | | | CC01 | |
| DI 8x24VDC SRC BA | ✓ | | | | | | | | | | CC02 | |
| DI 8xNAMUR HF | ✓ | | | | | | | | | | CC01 | |
| DI 4x120..230 VAC ST | | | | ✓ | | | | | | | CC41 | |
| DQ 16x24VDC/0.5A ST | ✓ | | | | | | | | | | CC00 | |
| DQ 4x24VDC/2 A ST | ✓ | | | | | | | | | | CC02 | |

1.1 Possible combinations of BaseUnits and I/O modules









| I/O module | BaseUnit BU15- | | BaseUnit BU20- | | | | | | | Color-coded label for process terminals | | |
|-------------------------|----------------------------------------------------|------------------------------------------------------------|----------------|------------|------------|------------|------------|------------|------------------------|-----------------------------------------|------|--|
| | BU type A0 | BU type A1 | BU type B0 | BU type B1 | BU type C0 | BU type C1 | BU type D0 | BU type F0 | BU type U0 | | | |
| | P16+A10+2D P16+A0+2D P16+A10+2B P16+A0+2B | P16+A0+12D/T P16+A0+2D/T P16+A0+12B/T P16+A0+2B/T | P12+A4+0B | P12+A0+4B | P6+A2+4D | P6+A2+4B | P12+A0+0B | P8+A4+0B | P16+A0+2D P16+A0+2B | | | |
| DQ 8x24VDC/0.5 ST | ✓ | | | | | | | | | | CC02 | |
| DQ 8x24VDC/0.5A HF | ✓ | | | | | | | | | | CC02 | |
| DQ 8x24VDC/0.5A BA | ✓ | | | | | | | | | | CC02 | |
| DQ 8x24VDC/0.5A SNK BA | ✓ | | | | | | | | | | CC01 | |
| DQ 4x24...230V AC/2A ST | | | | ✓ | | | | | | | CC41 | |
| DQ 4x24...230V AC/2A HF | | | | ✓ | | | | | | | CC20 | |
| DQ 4x24VDC/2A HF | ✓ | | | | | | | | | | CC02 | |
| DQ 4x24VDC/2A HS | ✓ | | | | | | | | | | CC00 | |

Module overview of ET 200SP







1.1 Possible combinations of BaseUnits and I/O modules

| I/O module | BaseUnit BU15- | | BaseUnit BU20- | | | | | | | Color-coded label for process terminals | |
|--------------------------------|----------------------------------------------------|------------------------------------------------------------|----------------|------------|------------|------------|------------|------------|------------------------|-----------------------------------------|---------|
| | BU type A0 | BU type A1 | BU type B0 | BU type B1 | BU type C0 | BU type C1 | BU type D0 | BU type F0 | BU type U0 | | |
| | P16+A10+2D P16+A0+2D P16+A10+2B P16+A0+2B | P16+A0+12D/Т P16+A0+2D/Т P16+A0+12B/Т P16+A0+2B/Т | P12+A4+0B | P12+A0+4B | P6+A2+4D | P6+A2+4B | P12+A0+0B | P8+A4+0B | P16+A0+2D P16+A0+2B | | |
| RQ 4x24VUC/2 A CO ST | ✓ | | | | | | | | | | CC00 |
| RQ 4x120VDC-230VAC/5A NO ST | | | ✓ | ✓ | | | | | | | --- --- |
| RQ 4x120VDC-230VAC/5A NO MA ST | | | ✓ | ✓ | | | | | | | --- --- |
| Analog I/O modules | | | | | | | | | | | |
| AI 4xRTD/TC 2-/3-/4-wire HF | ✓ | ✓ | | | | | | | | | CC00 |
| AI 8xRTD/TC 2-wire HF | ✓ | ✓ | | | | | | | | | CC00 |
| AI 8xU BA | ✓ | ✓ | | | | | | | | | CC02 |
| AI 2xU ST | ✓ | ✓ | | | | | | | | | CC00 |
| AI 2xI 2-/4-wire ST | ✓ | ✓ | | | | | | | | | CC05 |
| AI 4xU/I 2-wire ST | ✓ | ✓ | | | | | | | | | CC03 |

1.1 Possible combinations of BaseUnits and I/O modules

| I/O module | BaseUnit BU15- | | BaseUnit BU20- | | | | | | | Color-coded label for process terminals | | |
|-----------------------------|----------------------------------------------------|------------------------------------------------------------|----------------|------------|------------|------------|------------|------------|------------------------|-----------------------------------------|------|---------------------------------------------------------------------------------------|
| | BU type A0 | BU type A1 | BU type B0 | BU type B1 | BU type C0 | BU type C1 | BU type D0 | BU type F0 | BU type U0 | | | |
| | P16+A10+2D P16+A0+2D P16+A10+2B P16+A0+2B | P16+A0+12D/T P16+A0+2D/T P16+A0+12B/T P16+A0+2B/T | P12+A4+0B | P12+A0+4B | P6+A2+4D | P6+A2+4B | P12+A0+0B | P8+A4+0B | P16+A0+2D P16+A0+2B | | | |
| AI 2xU/I 2-/4-wire HF | ✓ | ✓ | | | | | | | | | CC05 |  |
| AI 2xU/I 2-/4-wire HS | ✓ | ✓ | | | | | | | | | CC00 |  |
| AI 8xI 2-/4-wire BA | ✓ | ✓ | | | | | | | | | CC01 |  |
| AI 4xI 2-/4-wire ST | ✓ | ✓ | | | | | | | | | CC03 |  |
| AI 4xI 2-wire 4...20mA HART | ✓ | ✓ | | | | | | | | | CC03 |  |
| AQ 2xU ST | ✓ | ✓ | | | | | | | | | CC00 |  |
| AQ 2xI ST | ✓ | ✓ | | | | | | | | | CC00 |  |
| AQ 4xU/I ST | ✓ | ✓ | | | | | | | | | CC00 |  |

1.1 Possible combinations of BaseUnits and I/O modules

| I/O module | BaseUnit BU15- | | BaseUnit BU20- | | | | | | | Color-coded label for process terminals | |
|-----------------------------|----------------------------------------------------|--------------------------------------------------------------|----------------|------------|------------|------------|------------|------------|------------------------|-----------------------------------------|---------------------------------------------------------------------------------------|
| | BU type A0 | BU type A1 | BU type B0 | BU type B1 | BU type C0 | BU type C1 | BU type D0 | BU type F0 | BU type U0 | | |
| | P16+A10+2D P16+A0+2D P16+A10+2B P16+A0+2B | P16+A0+12D /T P16+A0+2D/T P16+A0+12B /T P16+A0+2B/T | P12+A4+0B | P12+A0+4B | P6+A2+4D | P6+A2+4B | P12+A0+0B | P8+A4+0B | P16+A0+2D P16+A0+2B | | |
| AQ 2xU/I HS | ✓ | ✓ | | | | | | | | CC00 |  |
| AQ 2xU/I HF | ✓ | ✓ | | | | | | | | CC00 |  |
| AI Energy Meter 400VAC ST | | | | | | | ✓ | | | --- | --- |
| AI Energy Meter 480VAC ST | | | | | | | ✓ | | | --- | --- |
| Fail-safe modules | | | | | | | | | | | |
| F-PM-E 24VDC/8A PPM ST | | | | | ✓ | | | | | CC52 |  |
| F-DI 8x24VDC HF | ✓ | | | | | | | | | CC01 |  |
| F-DQ 4x24VDC/2 A PM HF | ✓ | | | | | | | | | CC02 |  |
| F-DQ 8x24VDC/0.5A PP HF | ✓ | | | | | | | | | CC02 |  |
| F-RQ 1x24VDC/2 4..230VAC/5A | | | | | | | | ✓ | | CC42 |  |

1.1 Possible combinations of BaseUnits and I/O modules

| I/O module | BaseUnit BU15- | | BaseUnit BU20- | | | | | | | Color-coded label for process terminals |
|------------------------------|----------------------------------------------------|------------------------------------------------------------|----------------|------------|------------|------------|------------|------------|------------------------|------------------------------------------------------------------------------------------|
| | BU type A0 | BU type A1 | BU type B0 | BU type B1 | BU type C0 | BU type C1 | BU type D0 | BU type F0 | BU type U0 | |
| | P16+A10+2D P16+A0+2D P16+A10+2B P16+A0+2B | P16+A0+12D/T P16+A0+2D/T P16+A0+12B/T P16+A0+2B/T | P12+A4+0B | P12+A0+4B | P6+A2+4D | P6+A2+4B | P12+A0+0B | P8+A4+0B | P16+A0+2D P16+A0+2B | |
| Communication modules | | | | | | | | | | |
| CM 4xIO-Link | ✓ | | | | | | | | | CC04  |
| CM AS-i Master ST | | | | | ✓ | | | | | --- |
| F-CM AS-i Safety ST | | | | | ✓ | ✓ | | | | --- |
| CM PtP | ✓ | | | | | | | | | --- |
| Technology modules | | | | | | | | | | |
| TM Count 1x24V | ✓ | | | | | | | | | --- |
| TM PosInput 1 | ✓ | | | | | | | | | --- |
| TM Timer DIDQ 10x24V | ✓ | | | | | | | | | --- |
| TM Pulse 2x24V | | | | ✓ | | | | | | --- |
| SIWAREX WP321 | ✓ | | | | | | | | | --- |

1.1 Possible combinations of BaseUnits and I/O modules

Table 1-2 Possible combinations of BaseUnits and motor starters

| Motor starters | BaseUnit BU30- | | | | | | Color-coded label for process terminals |
|------------------------------------|-----------------------------------------------|--------------------------------|-------------------------------|--------------------------|--------------------------------------------------------------|----------------------------------------------------|-----------------------------------------|
| | MS1 with infeed 24 V DC and 500 V AC | MS2 with infeed 500 V AC | MS3 with infeed 24 V DC | MS4 without infeed | MS5 with in- feed 500 V AC and F-DI terminals | MS6 without infeed with F-DI terminals | |
| Direct starter | | | | | | | |
| DS 0.3 - 1 A HF | | ✓ | | | ✓* | --- | --- |
| DS 0.9 - 3 A HF | | ✓ | | | ✓* | --- | --- |
| DS 2.8 - 9 A HF | | ✓ | | | ✓* | --- | --- |
| DS 4.0 - 12 A HF | | ✓ | | | ✓* | --- | --- |
| Reversing starter | | | | | | | |
| RS 0.3 - 1 A HF | | ✓ | | | ✓* | --- | --- |
| RS 0.9 - 3 A HF | | ✓ | | | ✓* | --- | --- |
| RS 2.8 - 9 A HF | | ✓ | | | ✓* | --- | --- |
| RS 4.0 - 12 A HF | | ✓ | | | ✓* | | |
| Failsafe direct starter | | | | | | | |
| F-DS 0.3 - 1 A HF | | ✓ | | | ✓ | --- | --- |
| F-DS 0.9 - 3 A HF | | ✓ | | | ✓ | --- | --- |
| F-DS 2.8 - 9 A HF | | ✓ | | | ✓ | --- | --- |
| F-DS 4.0 - 12 A HF | | ✓ | | | ✓ | --- | --- |
| Fail-safe reversing starter | | | | | | | |
| F-RS 0.3 - 1 A HF | | ✓ | | | ✓ | --- | --- |
| F-RS 0.9 - 3 A HF | | ✓ | | | ✓ | --- | --- |
| F-RS 2.8 - 9 A HF | | ✓ | | | ✓ | --- | --- |
| F-RS 4.0 - 12 A HF | | ✓ | | | ✓ | --- | --- |

* The F-DI terminals do not have a function in this combination.

Table 1-3 Combination possibilities between potential distributor BaseUnit and potential distributor terminal block

| Potential distributor terminal block | Potential distributor BaseUnit | | | |
|--------------------------------------|--------------------------------|------------------|------------------|------------------|
| | PotDis-BU-P1/D-R | PotDis-BU-P1/B-R | PotDis-BU-P2/D-B | PotDis-BU-P2/B-B |
| PotDis-TB-P1-R | ✓ | ✓ | ✓ | ✓ |
| PotDis-TB-P2-B | ✓ | ✓ | ✓ | ✓ |
| PotDis-TB-n.c.-G | ✓ | ✓ | ✓ | ✓ |
| PotDis-TB-BR-W | ✓ | ✓ | ✓ | ✓ |

1.2 CPUs

CPUs

| CPU | Number in pack | Article number |
|--------------------------------------|----------------|--------------------|
| CPU 1510SP-1 PN with server module | Pack of 1 | 6ES7510-1DJ0x-0AB0 |
| CPU 1510SP F-1 PN with server module | Pack of 1 | 6ES7510-1SJ0x-0AB0 |
| CPU 1512SP-1 PN with server module | Pack of 1 | 6ES7512-1DK0x-0AB0 |
| CPU 1512SP F-1 PN with server module | Pack of 1 | 6ES7512-1SK0x-0AB0 |
| CPU 1515SP PC with server module | Pack of 1 | 6ES7677-2AAxx-0xx0 |

| Important differences between CPUs...PN | | | | |
|---------------------------------------------------------------|-------------------------------------------------------------------------------------------------------------------------------------------------------------------------------------------------------|-------------------|---------------------------------------------------------------------------------------------------------------------------------------------------------------------------------------------------------------------------------------------------------------------------------------------------------------------------------------------------------------------------------------------------------------------------------------------------------------------------------------------------------------------------------------|-------------------|
| Features | CPU 1510SP-1 PN | CPU 1510SP F-1 PN | CPU 1512SP-1 PN | CPU 1512SP F-1 PN |
| Bus connection | PROFINET: BusAdapter (port 1, 2) <ul style="list-style-type: none"> BA 2xRJ45 (as of firmware version 1.6) BA 2xFC (as of firmware version V1.6) RJ45, integrated (port 3) | | PROFINET: BusAdapter (port 1, 2) <ul style="list-style-type: none"> BA 2xRJ45 (as of firmware version 1.6) BA 2xFC (as of firmware version V1.6) BA 2xSCRJ (as of firmware V1.8)¹ BA SCRJ/RJ45 (as of firmware V1.8)¹ BA SCRJ/FC (as of firmware V1.8)¹ BA 2xLC (as of firmware V2.0)¹ BA LC/RJ45 (as of firmware V2.0)¹ BA LC/FC (as of firmware V2.0)¹ RJ45, integrated (port 3) | |
| | PROFIBUS: PROFIBUS DP connection socket via CM DP communication module | | | |
| Number of modules | 64 | | | |
| Data work memory | 750 KB | 750 KB | 1 MB | 1 MB |
| Code work memory | 100 KB | 150 KB | 200 KB | 300 KB |
| Address space | 1280 bytes/2560 bytes ² | | | |
| Multi hot-swapping | Yes | | | |
| Can be used for safety applications (supports PROFIsafe V2.0) | No | Yes | No | Yes |

¹ Only with article numbers 6ES7512-1DK01-0AB0 and 6ES7512-1SK01-0AB0

² Only 6ES7510-1DJ01-0AB0, 6ES7512-1SJ01-0AB0, 6ES7512-1DK01-0AB0 and 6ES7512-1SK01-0AB0 with FW version V2.0

Note

The CM AS-i Master ST and F-CM AS-i Safety ST communication modules are supported as of firmware V1.8 of the CPUs. Note the following additional requirements:

CM AS-i Master ST:

- Firmware version of the CM AS-i Master ST: V1.1
- STEP 7 (TIA Portal): V13 SP1 Update 4 or higher

F-CM AS-i Safety ST

- Firmware version of the CM AS-i Safety ST: V1.0
- STEP 7 (TIA Portal): as of V13 SP1 Update 4 and HSP0070 V3.0

1.3 Interface modules

Interface modules

| Interface modules | Number in pack | Article number |
|----------------------------------------------------------------------------------------------------------------|----------------|--------------------|
| Interface module IM 155-6 PN BA | Pack of 1 | 6ES7155-6AR00-0AN0 |
| Interface module IM 155-6 PN ST | | |
| • with BusAdapter BA 2xRJ45 and server module | Pack of 1 | 6ES7155-6AA00-0BN0 |
| • with server module | Pack of 1 | 6ES7155-6AU00-0BN0 |
| Interface module IM 155-6 PN HF with server module | Pack of 1 | 6ES7155-6AU00-0CN0 |
| Interface module IM 155-6 PN HS with server module | Pack of 1 | 6ES7155-6AU00-0DN0 |
| Interface module IM 155-6 DP HF with PROFIBUS FastConnect bus connector (6ES7972-0BB70-0XA0) and server module | Pack of 1 | 6ES7155-6BA00-0CN0 |

| Important differences between the interface modules | | | | | |
|-----------------------------------------------------|------------------------------------|------------------------------------------------------------------------------------------------------------------------------------------------------|--------------------------------------------------------------------------------------------------------------------------------------------------------------------------------------------------------------------------------------------------------------------------------------------------------------------------------------------------------------------------------------------------------------------------|--------------------------------------------------------------------------------------------------------------------------------------------------------------------------------------------------------------------------------------------------------------------------------------------------------------------------------------------------------------------------------------------------------------------------|-----------------------------------------------|
| Features | IM 155-6 PN BA | IM 155-6 PN ST | IM 155-6 PN HF | IM 155-6 PN HS | IM 155-6 DP HF |
| Bus connection | PROFINET: 2xRJ45, integrated | PROFINET: BusAdapter <ul style="list-style-type: none"> • BA 2xRJ45 (as of firmware V1.0) • BA 2xFC (as of firmware V1.0) | PROFINET: BusAdapter <ul style="list-style-type: none"> • BA 2xRJ45 (as of firmware V2.0) • BA 2xFC (as of firmware V2.0) • BA 2xSCRJ (as of firmware V2.2) • BA SCRJ/RJ45 (as of firmware V3.1) • BA SCRJ/FC (as of firmware V3.1) • BA 2xLC (as of firmware V3.3) • BA LC/RJ45 (as of firmware V3.3) • BA LC/FC (as of firmware V3.3) | PROFINET: BusAdapter <ul style="list-style-type: none"> • BA 2xRJ45 (as of firmware V4.0) • BA 2xFC (as of firmware V4.0) • BA 2xSCRJ (as of firmware V4.0) • BA SCRJ/RJ45 (as of firmware V4.0) • BA SCRJ/FC (as of firmware V4.0) • BA 2xLC (as of firmware V4.0) • BA LC/RJ45 (as of firmware V4.0) • BA LC/FC (as of firmware V4.0) | PROFIBUS: PROFIBUS DP connection socket |
| Number of modules | 12 | 32 | 64 | 30 | 32 |
| RESET button | No | Yes | Yes | Yes | Not necessary |
| Address space (I/O data) | 32 bytes | 798 bytes | 1440 bytes | 968 bytes | 244 bytes |
| Multi hot-swapping | No | No | Yes | Yes | Yes |

Table 1- 4 Station expansion via ET-Connection (mixed configuration ET 200SP/ET 200AL)

| Modules | Number in pack | Article number |
|--------------|----------------|--------------------|
| BU-Send | Pack of 1 | 6ES7193-6BN00-0NE0 |
| BA-Send 1xFC | Pack of 1 | 6ES7193-6AS00-0AA0 |

1.4 BaseUnits

BaseUnits

Table 1- 5 BaseUnits for I/O modules

| BU type | BaseUnits (short name) | Color-coded labels* | Packaging unit | Article number |
|---------|------------------------|------------------------------------------------------|----------------|--------------------|
| A0 | BU15-P16+A10+2D | P16: CC00 to CC05 A10: CC71 to CC73 | Pack of 1 | 6ES7193-6BP20-0DA0 |
| | | | Pack of 10 | 6ES7193-6BP20-2DA0 |
| A0 | BU15-P16+A0+2D | P16: CC00 to CC05 | Pack of 1 | 6ES7193-6BP00-0DA0 |
| | | | Pack of 10 | 6ES7193-6BP00-2DA0 |
| A0 | BU15-P16+A10+2B | P16: CC00 to CC05 A10: CC71 to CC73 | Pack of 1 | 6ES7193-6BP20-0BA0 |
| | | | Pack of 10 | 6ES7193-6BP20-2BA0 |
| A0 | BU15-P16+A0+2B | P16: CC00 to CC05 | Pack of 1 | 6ES7193-6BP00-0BA0 |
| | | | Pack of 10 | 6ES7193-6BP00-2BA0 |
| A1 | BU15-P16+A0+12D/T | P16: CC00 to CC05 12D: CC74 | Pack of 1 | 6ES7193-6BP40-0DA1 |
| A1 | BU15-P16+A0+2D/T | P16: CC00 to CC05 | Pack of 1 | 6ES7193-6BP00-0DA1 |
| A1 | BU15-P16+A0+12B/T | P16: CC00 to CC05 12B: CC74 | Pack of 1 | 6ES7193-6BP40-0BA1 |
| A1 | BU15-P16+A0+2B/T | P16: CC00 to CC05 | Pack of 1 | 6ES7193-6BP00-0BA1 |
| B0 | BU20-P12+A4+0B | A4: CC81 to CC83 | Pack of 1 | 6ES7193-6BP20-0BB0 |
| | | | Pack of 10 | 6ES7193-6BP20-2BB0 |
| B1 | BU20-P12+A0+4B | P12: CC41 | Pack of 1 | 6ES7193-6BP20-0BB1 |
| C0 | BU20-P6+A2+4D | P6: CC51, CC52 A2: CC84 to CC86 | Pack of 1 | 6ES7193-6BP20-0DC0 |
| C1 | BU20-P6+A2+4B | P6: CC51 A2: CC84 to CC86 | Pack of 1 | 6ES7193-6BP20-0BC1 |
| D0 | BU20-P12+A0+0B | --- | Pack of 1 | 6ES7193-6BP00-0BD0 |
| F0 | BU20-P8+A4+0B | P8: CC42 | Pack of 1 | 6ES7193-6BP20-0BF0 |
| U0 | BU20-P16+A0+2D | P16: CC00 to CC05 | Pack of 1 | 6ES7193-6BP00-0BU0 |
| | | | Pack of 10 | 6ES7193-6BP00-2BU0 |
| U0 | BU20-P16+A0+2B | P16: CC00 to CC05 | Pack of 1 | 6ES7193-6BP00-0DU0 |
| | | | Pack of 10 | 6ES7193-6BP00-2DU0 |

* not included in the scope of delivery of the BaseUnit

Table 1- 6 BaseUnit PotDis

| PotDis type | Potential distributor (short name) | Color coded labels | Packaging unit | Article number |
|-------------|------------------------------------|--------------------|----------------|--------------------|
| P1 | PotDis-BU-P1/D-R | CC62 | Pack of 1 | 6ES7193-6UP00-0DP1 |
| P1 | PotDis-BU-P1/B-R | CC62 | Pack of 1 | 6ES7193-6UP00-0BP1 |

| PotDis type | Potential distributor (short name) | Color coded labels | Packaging unit | Article number |
|-------------|------------------------------------|--------------------|----------------|--------------------|
| P2 | PotDis-BU-P2/D-B | CC63 | Pack of 1 | 6ES7193-6UP00-0DP2 |
| P2 | PotDis-BU-P2/B-B | CC63 | Pack of 1 | 6ES7193-6UP00-0BP2 |

Table 1- 7 BaseUnit PotDis-TB

| Terminal block type | Terminal block (short name) | Color coded labels | Packaging unit | Article number |
|---------------------|-----------------------------|--------------------|----------------|--------------------|
| P1 | PotDis-TB-P1-R | CC12 | Pack of 1 | 6ES7193-6TP00-0TP1 |
| P2 | PotDis-TB-P2-B | CC13 | Pack of 1 | 6ES7193-6TP00-0TP2 |
| N0 | PotDis-TB-n.c.-G | CC10 | Pack of 1 | 6ES7193-6TP00-0TN0 |
| P0 | PotDis-TB-BR-W | CC10 | Pack of 1 | 6ES7193-6TP00-0TP0 |

Table 1- 8 BaseUnits for motor starters

| BU type | BaseUnits (short name) | Color-coded labels | Packaging unit | Article number |
|---------|------------------------|--------------------|----------------|--------------------|
| MS1 | BU30-MS1 | - | Pack of 1 | 3RK1908-0AP00-0AP0 |
| MS2 | BU30-MS2 | - | Pack of 1 | 3RK1908-0AP00-0CP0 |
| MS3 | BU30-MS3 | - | Pack of 1 | 3RK1908-0AP00-0BP0 |
| MS4 | BU30-MS4 | - | Pack of 1 | 3RK1908-0AP00-0DP0 |
| MS5 | BU30-MS5 | - | Pack of 1 | 3RK1908-0AP00-0EP0 |
| MS6 | BU30-MS6 | - | Pack of 1 | 3RK1908-0AP00-0FP0 |

1.5 I/O modules

I/O modules

| Digital I/O modules | Number in pack | Article number |
|--------------------------------|----------------|--------------------|
| DI 16x24VDC ST | Pack of 1 | 6ES7131-6BH00-0BA0 |
| | Pack of 10 | 6ES7131-6BH00-2BA0 |
| DI 8x24VDC ST | Pack of 1 | 6ES7131-6BF00-0BA0 |
| | Pack of 10 | 6ES7131-6BF00-2BA0 |
| DI 8x24VDC HF | Pack of 1 | 6ES7131-6BF00-0CA0 |
| DI 8x24VDC HS | Pack of 1 | 6ES7131-6BF00-0DA0 |
| DI 8xNAMUR HF | Pack of 1 | 6ES7131-6TF00-0CA0 |
| DI 8x24VDC BA | Pack of 1 | 6ES7131-6BF00-0AA0 |
| | Pack of 10 | 6ES7131-6BF00-2AA0 |
| DI 8x24VDC SRC BA | Pack of 1 | 6ES7131-6BF60-0AA0 |
| DI 4x120..230VAC ST | Pack of 1 | 6ES7131-6FD00-0BB1 |
| DQ 16x24VDC/0.5A ST | Pack of 1 | 6ES7132-6BH00-0BA0 |
| | Pack of 10 | 6ES7132-6BH00-2BA0 |
| DQ 8x24VDC/0.5A ST | Pack of 1 | 6ES7132-6BF00-0BA0 |
| | Pack of 10 | 6ES7132-6BF00-2BA0 |
| DQ 8x24VDC/0.5A HF | Pack of 1 | 6ES7132-6BF00-0CA0 |
| DQ 8x24VDC/0.5A BA | Pack of 1 | 6ES7132-6BF00-0AA0 |
| | Pack of 10 | 6ES7132-6BF00-2AA0 |
| DQ 8x24VDC/0.5A SNK BA | Pack of 1 | 6ES7132-6BF60-0AA0 |
| DQ 4x24VDC/2A ST | Pack of 1 | 6ES7132-6BD20-0BA0 |
| | Pack of 10 | 6ES7132-6BD20-2BA0 |
| DQ 4x24..230VAC/2A ST | Pack of 1 | 6ES7132-6FD00-0BB1 |
| | Pack of 10 | 6ES7132-6FD00-2BB1 |
| DQ 4x24..230VAC/2A HF | Pack of 1 | 6ES7132-6FD00-0CU0 |
| DQ 4x24VDC/2A HF | Pack of 1 | 6ES7132-6BD20-0CA0 |
| DQ 4x24VDC/2A HS | Pack of 1 | 6ES7132-6BD20-0DA0 |
| RQ 4x24VUC/2A CO ST | Pack of 1 | 6ES7132-6GD50-0BA0 |
| RQ 4x120VDC-230VAC/5A NO ST | Pack of 1 | 6ES7132-6HD00-0BB1 |
| | Pack of 10 | 6ES7132-6HD00-2BB1 |
| RQ 4x120VDC-230VAC/5A NO MA ST | Pack of 1 | 6ES7132-6MD00-0BB1 |

| Analog I/O modules | Number in pack | Article number |
|-----------------------------|----------------|--------------------|
| AI 8xU BA | Pack of 1 | 6ES7134-6FF00-0AA1 |
| AI 2xU ST | Pack of 1 | 6ES7134-6FB00-0BA1 |
| AI 4xU/I 2-wire ST | Pack of 1 | 6ES7134-6HD00-0BA1 |
| | Pack of 10 | 6ES7134-6HD00-2BA1 |
| AI 2xU/I 2-/4-wire HF | Pack of 1 | 6ES7134-6HB00-0CA1 |
| AI 2xU/I 2-/4-wire HS | Pack of 1 | 6ES7134-6HB00-0DA1 |
| AI 8xI 2-/4-wire BA | Pack of 1 | 6ES7134-6GF00-0AA1 |
| AI 2xI 2-/4-wire ST | Pack of 1 | 6ES7134-6GB00-0BA1 |
| AI 4xI 2-/4-wire ST | Pack of 1 | 6ES7134-6GD00-0BA1 |
| AI 8xRTD/TC 2-wire HF | Pack of 1 | 6ES7134-6JF00-0CA1 |
| | Pack of 10 | 6ES7134-6JF00-2CA1 |
| AI 4xRTD/TC 2-/3-/4-wire HF | Pack of 1 | 6ES7134-6JD00-0CA1 |
| | Pack of 10 | 6ES7134-6JD00-2CA1 |
| AI 4xI 2-wire 4...20mA HART | Pack of 1 | 6ES7134-6TD00-0CA1 |
| AQ 2xU ST | Pack of 1 | 6ES7135-6FB00-0BA1 |
| AQ 2xI ST | Pack of 1 | 6ES7135-6GB00-0BA1 |
| AQ 4xU/I ST | Pack of 1 | 6ES7135-6HD00-0BA1 |
| AQ 2xU/I HF | Pack of 1 | 6ES7135-6HB00-0CA1 |
| AQ 2xU/I HS | Pack of 1 | 6ES7135-6HB00-0DA1 |
| AI Energy Meter 400VAC ST | Pack of 1 | 6ES7134-6PA01-0BD0 |
| AI Energy Meter 480VAC ST | Pack of 1 | 6ES7134-6PA20-0BD0 |

| Fail-safe modules | Number in pack | Article number |
|-----------------------------|----------------|--------------------|
| F-PM-E 24VDC/8A PPM ST | Pack of 1 | 6ES7136-6PA00-0BC0 |
| F-DI 8x24VDC HF | Pack of 1 | 6ES7136-6BA00-0CA0 |
| F-DQ 4x24VDC/2A PM HF | Pack of 1 | 6ES7136-6DB00-0CA0 |
| F-DQ 8x24VDC/0.5A PP HF | Pack of 1 | 6ES7136-6DC00-0CA0 |
| F-RQ 1x24VDC/24...230VAC/5A | Pack of 1 | 6ES7136-6RA00-0BF0 |

| Communication modules | Number in pack | Article number |
|-----------------------|----------------|--------------------|
| CM 4xIO-Link | Pack of 1 | 6ES7137-6BD00-0BA0 |
| CM AS-i Master ST | Pack of 1 | 3RK7137-6SA00-0BC1 |
| F-CM AS-i Safety ST | Pack of 1 | 3RK7136-6SC00-0BC1 |
| CM PtP | Pack of 1 | 6ES7137-6AA00-0BA0 |
| CM DP (for CPU) | Pack of 1 | 6ES7545-5DA00-0AB0 |

| Technology module | Number in pack | Article number |
|----------------------|----------------|--------------------|
| TM Count 1x24V | Pack of 1 | 6ES7138-6AA00-0BA0 |
| TM PosInput 1 | Pack of 1 | 6ES7138-6BA00-0BA0 |
| TM Timer DIDQ 10x24V | Pack of 1 | 6ES7138-6CG00-0BA0 |
| TM Pulse 2x24V | Pack of 1 | 6ES7138-6DB00-0BB1 |
| SIWAREX WP321 | Pack of 1 | 7MH4138-6AA00-0BA0 |

1.6 Motor starters

Motor starters

| Direct starter | Packaging unit | Article number |
|------------------|----------------|--------------------|
| DS 0.3 - 1 A HF | Pack of 1 | 3RK1308-0AB00-0CP0 |
| DS 0.9 - 3 A HF | Pack of 1 | 3RK1308-0AC00-0CP0 |
| DS 2.8 - 9 A HF | Pack of 1 | 3RK1308-0AD00-0CP0 |
| DS 4.0 - 12 A HF | Pack of 1 | 3RK1308-0AE00-0CP0 |

| Reversing starter | Packaging unit | Article number |
|-------------------|----------------|--------------------|
| RS 0.3 - 1 A HF | Pack of 1 | 3RK1308-0BB00-0CP0 |
| RS 0.9 - 3 A HF | Pack of 1 | 3RK1308-0BC00-0CP0 |
| RS 2.8 - 9 A HF | Pack of 1 | 3RK1308-0BD00-0CP0 |
| RS 4.0 - 12 A HF | Pack of 1 | 3RK1308-0BE00-0CP0 |

| Failsafe direct starter | Number in pack | Article number |
|-------------------------|----------------|--------------------|
| F-DS 0.3 - 1 A HF | Pack of 1 | 3RK1308-0CB00-0CP0 |
| F-DS 0.9 - 3 A HF | Pack of 1 | 3RK1308-0CC00-0CP0 |
| F-DS 2.8 - 9 A HF | Pack of 1 | 3RK1308-0CD00-0CP0 |
| F-DS 4.0 - 12 A HF | Pack of 1 | 3RK1308-0CE00-0CP0 |











| Fail-safe reversing starter | Number in pack | Article number |
|-----------------------------|----------------|--------------------|
| F-RS 0.3 - 1 A HF | Pack of 1 | 3RK1308-0DB00-0CP0 |
| F-RS 0.9 - 3 A HF | Pack of 1 | 3RK1308-0DC00-0CP0 |
| F-RS 2.8 - 9 A HF | Pack of 1 | 3RK1308-0DD00-0CP0 |
| F-RS 4.0 - 12 A HF | Pack of 1 | 3RK1308-0DE00-0CP0 |









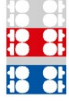

1.7 Accessories

Accessories









| General accessories | Packaging unit | Article number |
|------------------------------------------------------------------------------------------------------------------|----------------|--------------------|
| BusAdapter | | |
| • BA 2×RJ45 (PROFINET BusAdapter with standard Ethernet socket) | Pack of 1 | 6ES7193-6AR00-0AA0 |
| • BA 2×FC (PROFINET BusAdapter with FastConnect Ethernet connection) | Pack of 1 | 6ES7193-6AF00-0AA0 |
| • BA 2xSCRJ (PROFINET BusAdapter with POF/PCF fiber-optic cable connection) | Pack of 1 | 6ES7193-6AP00-0AA0 |
| • BA SCRJ/RJ45 (media converter, PROFINET BusAdapter with fiber-optic cable FOC ⇔ standard RJ45 connector) | Pack of 1 | 6ES7193-6AP20-0AA0 |
| • BA SCRJ/FC (media converter, PROFINET bus adapter with fiber-optic cable FOC ⇔ direct connection of bus cable) | Pack of 1 | 6ES7193-6AP40-0AA0 |
| • BA 2xLC (PROFINET BusAdapter with glass fiber-optic cable connection) | Pack of 1 | 6ES7193-6AG00-0AA0 |
| • BA LC/RJ45 (media converter, PROFINET BusAdapter with glass fiber-optic cable ⇔ standard RJ45 connector) | Pack of 1 | 6ES7193-6AG20-0AA0 |
| • BA LC/FC (Media converter, PROFINET bus adapter with glass fiber-optic cable ⇔ direct connection of bus cable) | Pack of 1 | 6ES7193-6AG40-0AA0 |
| PROFIBUS FastConnect bus connector | Pack of 1 | 6ES7972-0BB70-0XA0 |
| Server module (spare part) | Pack of 1 | 6ES7193-6PA00-0AA0 |
| BU cover | | |
| • 15 mm wide | Pack of 5 | 6ES7133-6CV15-1AM0 |
| • 20 mm wide | Pack of 5 | 6ES7133-6CV20-1AM0 |
| Shield connector for BaseUnit (shield contacts and shield terminals) | Pack of 5 | 6ES7193-6SC00-1AM0 |
| Reference identification label, sheet with 16 labels | Pack of 10 | 6ES7193-6LF30-0AW0 |
| Labeling strips (for labeling the I/O modules) | | |
| • Roll, light gray (with a total of 500 labeling strips) | Pack of 1 | 6ES7193-6LR10-0AA0 |
| • Roll, yellow (with a total of 500 labeling strips) | Pack of 1 | 6ES7193-6LR10-0AG0 |
| • DIN A4 sheets, light gray (with a total of 1000 labeling strips) | Pack of 10 | 6ES7193-6LA10-0AA0 |
| • DIN A4 sheets, yellow (with a total of 1000 labeling strips) | Pack of 10 | 6ES7193-6LA10-0AG0 |
| Mounting rails, tin-plated steel strip | | |
| • Length: 483 mm | Pack of 1 | 6ES5710-8MA11 |
| • Length: 530 mm | Pack of 1 | 6ES5710-8MA21 |
| • Length: 830 mm | Pack of 1 | 6ES5710-8MA31 |
| • Length: 2000 mm | Pack of 1 | 6ES5710-8MA41 |



1.7 Accessories

| Accessories, color identification labels (push-in terminals), 15 mm wide | Packaging unit | | Article number |
|----------------------------------------------------------------------------------------------------------------------------------------------------|----------------|-------------------------------------------------------------------------------------|--------------------|
| 16 process terminals (you can find additional information in the I/O Module manual) | | | |
| <ul style="list-style-type: none"> Gray (terminals 1 to 16); color code CC00 | Pack of 10 |  | 6ES7193-6CP00-2MA0 |
| <ul style="list-style-type: none"> Gray (terminals 1 to 8), red (terminals 9 to 16); color code CC01 | Pack of 10 |  | 6ES7193-6CP01-2MA0 |
| <ul style="list-style-type: none"> Gray (terminals 1 to 8), blue (terminals 9 to 16); color code CC02 | Pack of 10 |  | 6ES7193-6CP02-2MA0 |
| <ul style="list-style-type: none"> Gray (terminals 1 to 8), red (terminals 9 to 12), gray (terminals 13 to 16); color code CC03 | Pack of 10 |  | 6ES7193-6CP03-2MA0 |
| <ul style="list-style-type: none"> Gray (terminals 1 to 8), red (terminals 9 to 12), blue (terminals 13 to 16); color code CC04 | Pack of 10 |  | 6ES7193-6CP04-2MA0 |
| <ul style="list-style-type: none"> Gray (terminals 1 to 12), red (terminals 13 and 14), blue (terminals 15 and 16); color code CC05 | Pack of 10 |  | 6ES7193-6CP05-2MA0 |
| 10 AUX terminals (for BU15-P16+A10+2D, BU15-P16+A10+2B) | | | |
| <ul style="list-style-type: none"> Yellow-green (terminals 1A to 10A); color code CC71 | Pack of 10 |  | 6ES7193-6CP71-2AA0 |
| <ul style="list-style-type: none"> Red (terminals 1A to 10A); color code CC72 | Pack of 10 |  | 6ES7193-6CP72-2AA0 |
| <ul style="list-style-type: none"> Blue (terminals 1A to 10A); color code CC73 | Pack of 10 |  | 6ES7193-6CP73-2AA0 |
| 10 add-on terminals (for BU15-P16+A0+12D/T, BU15-P16+A0+12B/T) | | | |
| <ul style="list-style-type: none"> Red (terminals 1B to 5B), blue (terminals 1 to 5C); color code CC74 | Pack of 10 |  | 6ES7193-6CP74-2AA0 |

| Accessories, color identification labels (push-in terminals), 20 mm wide | Packaging unit | | Article number |
|--------------------------------------------------------------------------------------------------------------------------------------------------|----------------|--------------------------------------------------------------------------------------|--------------------|
| 12 process terminals (you can find additional information in the I/O Module manual) | | | |
| <ul style="list-style-type: none"> Gray (terminals 1 to 4), red (terminals 5 to 8), blue (terminals 9 to 12); color code CC41 | Pack of 10 |  | 6ES7193-6CP41-2MB0 |
| <ul style="list-style-type: none"> Gray (terminals 1 to 8), red (terminals 9 and 10), blue (terminals 11 and 12), color code CC42 | Pack of 10 |  | 6ES7193-6CP42-2MB0 |
| 6 process terminals (you can find additional information in the I/O Module manual) | | | |
| <ul style="list-style-type: none"> Gray (terminals 1 to 4), red (terminal 5), blue (terminal 6); color code CC51 | Pack of 10 |  | 6ES7193-6CP51-2MC0 |
| <ul style="list-style-type: none"> Gray (terminals 1, 2 and 5), red (terminals 3 and 4), blue (terminal 6); color code CC52 | Pack of 10 |  | 6ES7193-6CP52-2MC0 |
| 4 AUX terminals (for BU20-P12+A4+0B) | | | |
| <ul style="list-style-type: none"> Yellow-green (terminals 1A to 4A); color code CC81 | Pack of 10 |  | 6ES7193-6CP81-2AB0 |
| <ul style="list-style-type: none"> Red (terminals 1A to 4A); color code CC82 | Pack of 10 |  | 6ES7193-6CP82-2AB0 |
| <ul style="list-style-type: none"> Blue (terminals 1A to 4A); color code CC83 | Pack of 10 |  | 6ES7193-6CP83-2AB0 |
| 2 AUX terminals (for BU20-P6+A2+4D, BU20-P6+A2+4B) | | | |
| <ul style="list-style-type: none"> Yellow-green (terminals 1A and 2A); color code CC84 | Pack of 10 |  | 6ES7193-6CP84-2AC0 |
| <ul style="list-style-type: none"> Red (terminals 1A and 2A); color code CC85 | Pack of 10 |  | 6ES7193-6CP85-2AC0 |
| <ul style="list-style-type: none"> Blue (terminals 1A and 2A); color code CC86 | Pack of 10 |  | 6ES7193-6CP86-2AC0 |

1.7 Accessories

| Accessories, color identification labels (push-in terminals) PotDis | Packaging unit | | Article number |
|------------------------------------------------------------------------------------------------------------------|----------------|-------------------------------------------------------------------------------------|--------------------|
| PotDis-BU, 16 potential terminals | | | |
| <ul style="list-style-type: none"> Red for PotDis-BU-P1/x-R (terminals 1 to 16); color code CC62 | Pack of 10 |  | 6ES7193-6CP62-2MA0 |
| <ul style="list-style-type: none"> Blue for PotDis-BU-P2/x-B (terminals 1 to 16), color code CC63 | Pack of 10 |  | 6ES7193-6CP63-2MA0 |
| PotDis-TB-P1-R, 18 potential terminals | | | |
| <ul style="list-style-type: none"> Red (terminals 1 to 18); color code CC12 | Pack of 10 |  | 6ES7193-6CP12-2MT0 |
| <ul style="list-style-type: none"> Gray (terminals 1 to 18); color code CC10 | Pack of 10 |  | 6ES7193-6CP10-2MT0 |
| PotDis-TB-P2-B, 18 potential terminals | | | |
| <ul style="list-style-type: none"> Blue (terminals 1 to 18); color code CC13 | Pack of 10 |  | 6ES7193-6CP13-2MT0 |
| <ul style="list-style-type: none"> Gray (terminals 1 to 18); color code CC10 | Pack of 10 |  | 6ES7193-6CP10-2MT0 |
| PotDis-TB-BR-W, 18 potential terminals | | | |
| <ul style="list-style-type: none"> Yellow/green (terminals 1 to 18); color code CC11 | Pack of 10 |  | 6ES7193-6CP11-2MT0 |
| <ul style="list-style-type: none"> Red (terminals 1 to 18); color code CC12 | Pack of 10 |  | 6ES7193-6CP12-2MT0 |

| Accessories, color identification labels (push-in terminals) PotDis | Packaging unit | | Article number |
|---------------------------------------------------------------------------------------------|----------------|-----------------------------------------------------------------------------------|--------------------|
| <ul style="list-style-type: none"> Blue (terminals 1 to 18); color code CC13 | Pack of 10 |  | 6ES7193-6CP13-2MT0 |
| <ul style="list-style-type: none"> Gray (terminals 1 to 18); color code CC10 | Pack of 10 |  | 6ES7193-6CP10-2MT0 |
| PotDis-TB-n.c.-G, 18 potential terminals | | | |
| <ul style="list-style-type: none"> Gray (terminals 1 to 18); color code CC10 | Pack of 10 |  | 6ES7193-6CP10-2MT0 |

| Accessories for motor starter | Packaging unit | Article number |
|--------------------------------------------|----------------|--------------------|
| 3DI / LC module | Pack of 1 | 3RK1908-1AA00-0BP0 |
| Fan | Pack of 1 | 3RW4928-8VB00 |
| Additional mechanical bracket for BaseUnit | Pack of 1 | 3RK1908-1EA00-1BP0 |
| Cover for an empty BaseUnit | Pack of 1 | 3RK1908-1CA00-0BP0 |
| Touch protection cover for infeed bus | Pack of 1 | 3RK1908-1DA00-2BP0 |

Supplements to ET 200SP documentation

2.1 Using the SIMATIC ET 200SP over 2000 m above sea level.

The type test of the SIMATIC ET 200SP is based on IEC 61131-2: 2007. According to test conditions of IEC 61131-2: 2007, the permissible ambient temperature refers to an air pressure of 795 hPa to 1140 hPa. The specified air pressure corresponds to operation at elevations from -1000 m to 2000 m.

Elevations above 2000 m are possible. The maximum "operating elevation in relation to sea level" depends on the module and is described in the technical specifications of the respective module.

The certificates are generally issued for elevations up to 2000 m, as the underlying test standards do not consider higher elevations for installation.

According to IEC 61131-2: 2017, a temperature derating of 10 % per 1000 m must be taken into account for elevations above 2000 m.

Example:

The following diagram shows the permissible ambient temperature as a function of the installation elevation and the mounting position for the DI16x24VDC ST digital input module.

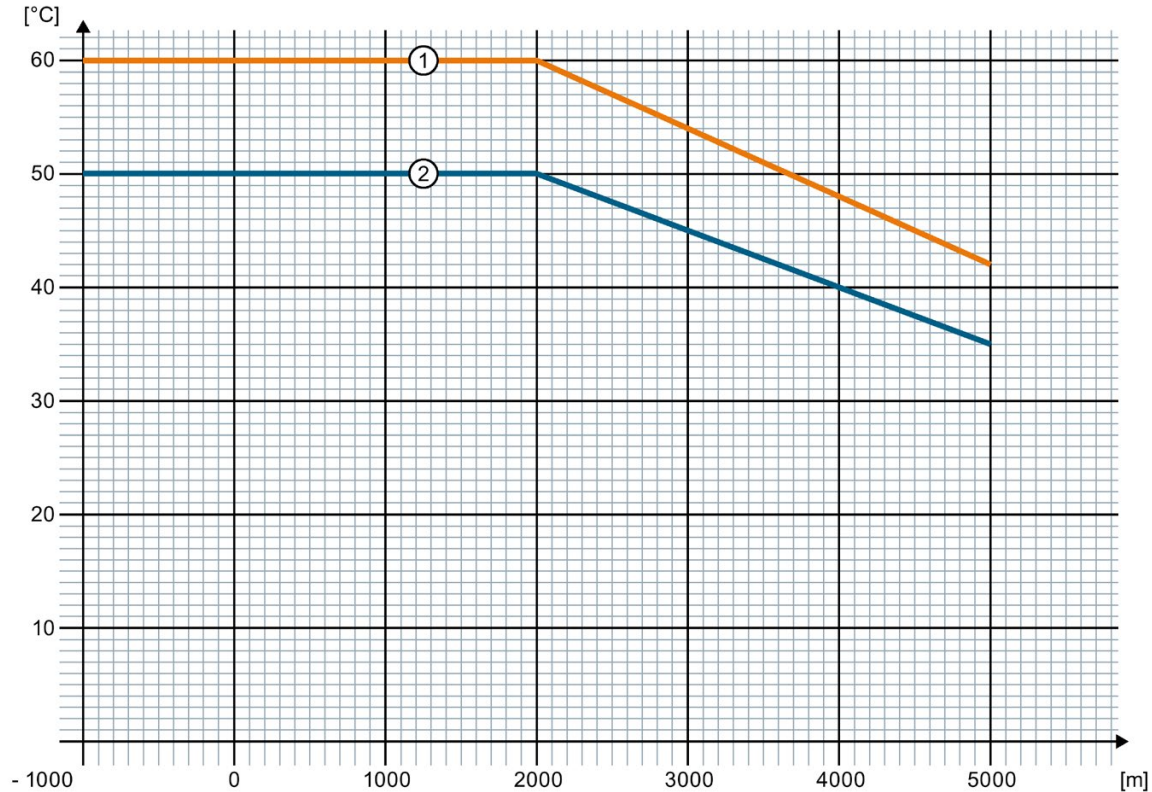

- ① Permissible ambient temperature with vertical mounting
- ② Permissible ambient temperature with horizontal mounting

Figure 2-1 Derating of the ambient temperature (°C) depending on the installation elevation (m) and the mounting position.

For further questions regarding installation elevations above 2000 m, please contact Technical Support. Your personal contact can be found on the Internet (https://www.automation.siemens.com/aspa_app/?ci=yes&lang=en®id=WW).

2.2 System manual

System manual ET 200SP Distributed I/O system, Edition 02/2018

Section 13.6 Firmware update

Modules with firmware version V0.0.0 do not support the "firmware update" function.

2.3 BaseUnits manual

2.3.1 Special consideration for BaseUnits with functional versions < 04

The following BaseUnits with functional version < 04 can only be used in potential groups with rated voltages ≤ 48 V DC or 24 V AC:

- BaseUnit BU20-P12+A0+4B (6ES7193-6BP20-0BB1).
- BaseUnit BU20-P12+A0+0B (6ES7193-6BP00-0BD0).

2.3.2 Terminal labeling of the PotDis-TB

New specification of the terminal labeling

New specification offers the following advantages:

- Unique terminal numbering per slot, even though the same reference identifier is used for the PotDis-BU and the PotDis-TB of a slot.
- Best possible readability
- Shortest possible designation to keep the work for conductor labeling as low as possible
- Compliant with ECAD rules
- Complies with the previous ET 200SP Logic
- You can continue using the color identification label CC00

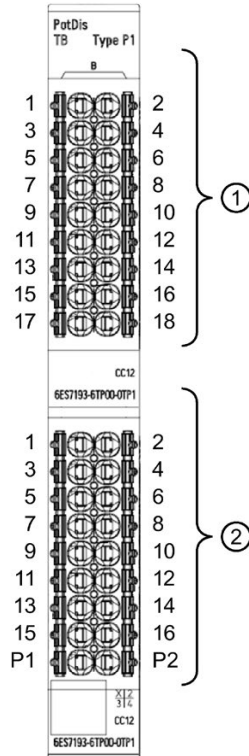

- ① **Terminal labeling of the PotDis-TB**
- ② **Terminal labeling of the PotDis-BU**

B1 to B18. To save space the preceding character "B" is printed once at the top and may not be covered by the color identification labels.

1 to 16, the supply terminals P1 and P2.

2.4 CPU manuals

Manual CPU 1512SP-1 PN, Edition 09/2016

Section 4.1 Status and error display of the CPU

MT1/MT2 LEDs on BusAdapter BA 2xSCRJ, BA SCRJ/RJ45, BA SCRJ/FC

Table 2- 1 Status and error displays of MT1/MT2 LEDs

| LED | Meaning | Solution |
|------------------|---------------------------------------------------------------------------------------------------------------------------------------------------------------------------------------------------------|-----------------------------------------------------------------------------------------------------------------------------------------------------------------------------------------------------------------------------------------------------------------------------------------------------------------------------------------------------------------------|
| MT1/MT2* | | |
| <p>□ Off</p> | No error | --- |
| <p>■ On</p> | <ul style="list-style-type: none"> Fiber-optic error Maintenance demanded: Attenuation through the fiber-optic cable is so high that operation will soon no longer be possible. | <p>Causes and measures for the transmission route:</p> <ul style="list-style-type: none"> Replacement of fiber-optic cable if damaged or aged Correct installation of the PROFINET connector/PROFINET connections Adherence to maximum length of 50 m for POF cable or 100 m for PCF cable Secure fit of the FOC connector. |

* Only available on BusAdapter BA 2xSCRJ

Section 6 Technical specifications

Technical specifications of the BusAdapters BA 2xSCRJ, BA SCRJ/RJ45, BA SCRJ/FC

The maximum length of the PCF-GI fiber-optic cable is 250 m.

Device manuals CPU 1510SP-1 PN and CPU 1512SP-1 PN, Edition 09/2016

"LED" instruction

You can read the status (e.g. "On" or "Off") of LEDs of a CPU or a module using the "LED" instruction. Note, however, that is not possible to read the LED status of the LINK RX/TX LEDs of the CPU 1510SP-1 PN and CPU 1512SP-1 PN.

You can find additional information on the "LED" instruction in the STEP 7 online help.

2.5 Interface module manuals

Configuration notes on interface modules depending on the I/O modules

| Module | Firmware version | IM 155-6 PN BA | IM 155-6 PN ST | | | | IM 155-6 PN HF | | | | | | IM 155-6 PN HS | IM 155-DP HF | | | |
|--------------------------------|------------------|----------------|----------------|------|------|------|----------------|------|------|------|------|------|----------------|--------------|------|------|------|
| | | V3.2 | V1.0 | V1.1 | V3.1 | V3.3 | V2.0 | V2.1 | V2.2 | V3.0 | V3.1 | V3.3 | V4.0 | V1.0 | V1.1 | V3.0 | V3.1 |
| AI 2xI 2-/4-wire ST | V1.0 | ✓ | --- | --- | ✓ | ✓ | --- | --- | --- | ✓ | ✓ | ✓ | ✓ | --- | --- | ✓ | ✓ |
| AI 2xU ST | V1.0 | ✓ | --- | --- | ✓ | ✓ | --- | --- | --- | ✓ | ✓ | ✓ | ✓ | --- | --- | ✓ | ✓ |
| AI 2xU/I 2-/4-wire HF | V2.0 | ✓ | ✓ | ✓ | ✓ | ✓ | ✓ | ✓ | ✓ | ✓ | ✓ | ✓ | ✓ | ✓ | ✓ | ✓ | ✓ |
| AI 8xI 2-/4-wire BA | V1.0 | ✓ | --- | ✓ | ✓ | ✓ | --- | --- | ✓ | ✓ | ✓ | ✓ | ✓ | --- | ✓ | ✓ | ✓ |
| AI 8xU BA | V1.0 | ✓ | --- | ✓ | ✓ | ✓ | --- | --- | ✓ | ✓ | ✓ | ✓ | ✓ | --- | ✓ | ✓ | ✓ |
| AI Energy Meter 400VAC ST | V3.0 | ✓ | ✓ | ✓ | ✓ | ✓ | ✓ | ✓ | ✓ | ✓ | ✓ | ✓ | ✓ | ✓ | ✓ | ✓ | ✓ |
| AI Energy Meter 480VAC ST | V4.0 | ✓ | --- | --- | ✓ | ✓ | --- | --- | --- | ✓ | ✓ | ✓ | ✓ | --- | --- | ✓ | ✓ |
| AQ 2xI ST | V1.0 | ✓ | --- | --- | ✓ | ✓ | --- | --- | --- | ✓ | ✓ | ✓ | ✓ | --- | --- | ✓ | ✓ |
| AQ 2xU ST | V1.0 | ✓ | --- | --- | ✓ | ✓ | --- | --- | --- | ✓ | ✓ | ✓ | ✓ | --- | --- | ✓ | ✓ |
| DI 8x24VDC BA | V1.0 | ✓ | --- | ✓ | ✓ | ✓ | --- | --- | ✓ | ✓ | ✓ | ✓ | ✓ | --- | ✓ | ✓ | ✓ |
| DI 8x24VDC HS | V1.0 | ✓ | --- | ✓ | ✓ | ✓ | --- | --- | ✓ | ✓ | ✓ | ✓ | ✓ | --- | ✓ | ✓ | ✓ |
| DI 8x24VDC HF | V2.0 | ✓ | ✓ | ✓ | ✓ | ✓ | ✓ | ✓ | ✓ | ✓ | ✓ | ✓ | ✓ | ✓ | ✓ | ✓ | ✓ |
| DI 16x24VDC ST | V1.1 | ✓ | ✓ | ✓ | ✓ | ✓ | ✓ | ✓ | ✓ | ✓ | ✓ | ✓ | ✓ | ✓ | ✓ | ✓ | ✓ |
| DQ 4x24VDC/2A HS | V1.0 | ✓ | --- | ✓ | ✓ | ✓ | --- | --- | ✓ | ✓ | ✓ | ✓ | ✓ | --- | ✓ | ✓ | ✓ |
| DQ 4x24VDC/2A HF | V2.0 | ✓ | ✓ | ✓ | ✓ | ✓ | ✓ | ✓ | ✓ | ✓ | ✓ | ✓ | ✓ | ✓ | ✓ | ✓ | ✓ |
| DQ 4x24 ... 230VAC/2A HF | V1.0 | ✓ | --- | --- | --- | ✓ | --- | --- | --- | --- | ✓ | ✓ | ✓ | --- | --- | ✓ | ✓ |
| RQ 4x120VDC-230VAC/5A NO MA ST | V1.0 | ✓ | --- | --- | ✓ | ✓ | --- | --- | --- | ✓ | ✓ | ✓ | ✓ | --- | --- | ✓ | ✓ |
| DQ 8x24VDC/0.5A HF | V2.0 | ✓ | ✓ | ✓ | ✓ | ✓ | ✓ | ✓ | ✓ | ✓ | ✓ | ✓ | ✓ | ✓ | ✓ | ✓ | ✓ |
| DQ 8x24VDC/0.5A BA | V1.0 | ✓ | --- | --- | ✓ | ✓ | --- | --- | --- | ✓ | ✓ | ✓ | ✓ | --- | --- | ✓ | ✓ |
| DQ 16x24VDC/0.5A BA | V0.0 | ✓ | --- | --- | --- | ✓ | --- | --- | --- | --- | ✓ | ✓ | ✓ | --- | --- | ✓ | ✓ |
| DQ 16x24VDC/0.5A ST | V1.1 | ✓ | ✓ | ✓ | ✓ | ✓ | ✓ | ✓ | ✓ | ✓ | ✓ | ✓ | ✓ | ✓ | ✓ | ✓ | ✓ |
| PotDis-TB-P1-R | - | ✓ | --- | --- | --- | ✓ | --- | --- | --- | --- | ✓ | ✓ | ✓ | --- | --- | ✓ | ✓ |
| PotDis-TB-P2-B | - | ✓ | --- | --- | --- | ✓ | --- | --- | --- | --- | ✓ | ✓ | ✓ | --- | --- | ✓ | ✓ |
| PotDis-TB-n.c.-G | - | ✓ | --- | --- | --- | ✓ | --- | --- | --- | --- | ✓ | ✓ | ✓ | --- | --- | ✓ | ✓ |
| PotDis-TB-BR-W | - | ✓ | --- | --- | --- | ✓ | --- | --- | --- | --- | ✓ | ✓ | ✓ | --- | --- | ✓ | ✓ |

--- This combination is not permitted in the configuration

IM 155-6 PN ST Manual, Edition 04/2017

Response times

The response time of the IM 155-6 PN ST is made up of:

- Backplane bus cycle time
- Operating system processing

Note

Validity of the formula

The following formula applies to the ET 200SP backplane bus.

The formula does not apply to the ET-Connection bus.

Backplane bus cycle time

The backplane bus cycle time is the time the interface module requires to output new output data, read new input data and then copy the data to the PROFINET send buffer.

The backplane bus cycle time is the result of the update time configured for the interface module as IO device and amounts to at least 1 ms.

- If the configured update time ≥ 1 ms, the backplane bus cycle time is equal to the configured update time.
- If the configured update time < 1 ms, the backplane bus cycle time is the product of an integer multiple of the configured update time.

Table 2- 2 Example calculation

| Configured update time | Backplane bus cycle time (integer multiple, minimum 1 ms) |
|------------------------|-----------------------------------------------------------|
| 250 μ s | 4 x 250 μ s = 1000 μ s |
| 750 μ s | 2 x 750 μ s = 1500 μ s |
| 1000 μ s | 1000 μ s |
| 2000 μ s | 2000 μ s |

Operating system processing time

The operating system processing time is calculated based on the following formula:

Operating system processing time output

$$\text{Operating system processing time_output}[\mu\text{s}] = 147 + 3.775 \text{ number_m} + 0.275 \text{ bytes_out}$$

Operating system processing time input

$$\text{Operating system processing time_input}[\mu\text{s}] = 158.3 + 2.325 \text{ number_m} + 0.325 \text{ bytes_in}$$

Explanation of the parameters:

Number_m: Total number of all modules (incl. server module)

Bytes_out: Sum of all output bytes

Bytes_in: Sum of all input bytes

Calculating the response time

Response time output

The response time output of the IM 155-6 PN ST is made up of:

- Backplane bus cycle time
- Operating system processing time_output.

Response time input

The response time input of the IM 155-6 PN ST is made up of:

- Backplane bus cycle time
- Operating system processing time_input.

IM 155-6 PN HF manual, Edition 12/2015

Section 3.1 Pin assignment

PROFINET interface X1 Port 2:

If autonegotiation is disabled, the RJ-45 socket (X1 Port 2) has the switch assignment (MDI-X).

Section 5.3.3 Channel diagnostics

Coding of the extended channel diagnostics (as of firmware version V3.3.0)

With the IM 155-6 PN HF interface module, the following extended channel diagnostics are reported:

| Slot number | ChannelError-Type (CET) | ExtendedChannel-ErrorType (ECET) | Associated value AddValue | Diagnostics |
|--------------------|-------------------------|----------------------------------|---------------------------|---------------------------------------------------------------------------------------------------------------------------------------------------------------------------------------------------------------|
| Module slot | 0x0602 | 0x0691 | Slot | Station stop - module parameter "Potential group" faulty or incorrect BaseUnit in actual slot (AddValue) |
| Slot 0 | 0x0602 | 0x0693 | 0x00 | Diagnostics with missing server module |
| | 0x0602 | 0x0698 | 0x00 | Diagnostics backplane bus too long |
| | 0x0602 | 0x0699 | Slot | Diagnostics with incorrect bus configuration |
| | 0x0602 | 0x069C | 0x00 | Diagnostics with incorrectly plugged BusAdapter |
| Server module slot | 0x0610 | 0x06B0 | 0x00 | Group diagnostics: Missing supply voltage L+ for the potential groups Note: The slot in which the light-colored BaseUnit of the respective load module is located is coded in the "ChannelNumber" element. |

Section 6.1 Compatibility of modules

Compatibility of the interface module IM 155-6 PN HF:

For the compatibility of the interface module IM 155-6 PN ST take into account that the interface module IM 155-6 PN HF solely supports the transmission rate of 100 Mbps for Ethernet services.

Section 7 Technical specifications

- Technical specifications of the BusAdapters BA 2xSCRJ, BA SCRJ/RJ45, BA SCRJ/FC:
The maximum length of the PCF-GI fiber-optic cable is 250 m.
- Technical specifications of the BusAdapters BA 2xLC, BA LC/RJ45, BA LC/FC:
Cable length:
 - Multimode graded index fiber 50/125 µm: 3 km
 - Multimode graded index fiber 62.5/125 µm: 3 km

IM 155-6 PN HS manual, Edition 09/2016

Section 3.1 Pin assignment

PROFINET interface X1 Port 2:

If autonegotiation is disabled, the RJ-45 socket (X1 Port 2) has the switch assignment (MDI-X).

Section 7 Technical specifications

- The PROFINET certification of network Class 3 is in preparation.
- Technical specifications of the BusAdapters BA 2×SCRJ, BA SCRJ/RJ45, BA SCRJ/FC: The maximum length of the PCF-GI fiber-optic cable is 250 m.

2.6 I/O module manuals

Configuration notes on the I/O modules
(supplement to Product overview section in the manual)

| I/O module | | Order number | Firmware version | STEP 7 (TIA Portal) | STEP 7 V5.5 SP3 |
|------------------------|---------------------|--------------------|------------------|---------------------------------------|-----------------|
| Digital input modules | DI 16x24VDC ST | 6ES7131-6BH00-0BA0 | V1.1.0 | HSP0162 V13 SP1 or higher | HSP0229 V6.0 |
| | DI 8x24VDC BA | 6ES7131-6BF00-0AA0 | V1.0.0 | HSP0126 | HSP0229 V5.0 |
| | DI 8x24VDC ST | 6ES7131-6BF00-0BA0 | V1.1.0 | V13 Update 3 | HSP0229 V4.0 |
| | DI 8x24VDC HF | 6ES7131-6BF00-0CA0 | V2.0.0 | HSP0163 V13 SP1 Update 4 or higher | HSP0229 V6.0 |
| | DI 8x24VDC HS | 6ES7131-6BF00-0DA0 | V1.0.2 | Integrated as of V14 | HSP0229 V5.0 |
| Digital output modules | DQ 8x24VDC/0.5A BA | 6ES7132-6BF00-0AA1 | V1.0.0 | HSP0162 V13 SP1 or higher | HSP0230 V6.0 |
| | DQ 4x24VDC/2A ST | 6ES7132-6BD20-0BA0 | V1.1.0 | V13 Update 3 | HSP0230 V4.0 |
| | DQ 8x24VDC/0.5A ST | 6ES7132-6BF00-0BA0 | V1.1.0 | V13 Update 3 | HSP0230 V4.0 |
| | DQ 16x24VDC/0.5A ST | 6ES7132-6BH00-0BA0 | V1.1.0 | HSP0162 V13 SP1 or higher | HSP0230 V6.0 |
| | DQ 8x24VDC/0.5A HF | 6ES7132-6BF00-0CA0 | V2.0.0 | HSP0163 V13 SP1 Update 4 or higher | HSP0230 V6.0 |

| I/O module | | Order number | Firmware version | STEP 7 (TIA Portal) | STEP 7 V5.5 SP3 |
|----------------------|--------------------------------|--------------------|------------------|---------------------------------------|----------------------------------------|
| | DQ 4x24VDC/2A HF | 6ES7132-6BD20-0CA0 | V2.0.0 | HSP0163 V13 SP1 Update 4 or higher | HSP0230 V6.0 |
| | DQ 4x24VDC/2A HS | 6ES7132-6BD20-0DA0 | V1.0.2 | Integrated as of V14 | HSP0230 V5.0 |
| | DQ 4x24...230VAC/2A ST | 6ES7132-6FD00-0BB1 | V1.0 | as of V13 | HSP0230 V3.0 |
| | DQ 4x24...230VAC/2A HF | 6ES7132-6FD00-0CU0 | V1.0.0 | as of V14 with HSP0240 | HSP 0230 as of V8.0 |
| | RQ 4x120VDC-230VAC/5A NO ST | 6ES7132-6HD00-0BB1 | V1.0.0 | HSP0128 | HSP0232 V5.0 |
| | RQ 4x120VDC-230VAC/5A NO MA ST | 6ES7132-6MD00-0BB1 | V1.0.0 | HSP0162 V13 SP1 or higher | HSP0232 V6.0 |
| Analog input modules | AI 8xU BA | 6ES7134-6FF00-0AA1 | V1.0.0 | HSP0126 | HSP0227 V5.0 |
| | AI 2xU ST | 6ES7134-6FB00-0BA1 | V1.0.0 | HSP0160 V13 SP1 or higher | HSP0227 V6.0 |
| | AI 8xI 2-/4-wire BA | 6ES7134-6GF000AA1 | V1.0.0 | HSP0126 | HSP0227 V5.0 |
| | AI 4xI 2-/4-wire ST | 6ES7134-6GD00-0BA1 | V1.1.0 | V13 Update 3 | HSP0227 V4.0 |
| | AI 2xI 2-/4-wire ST | 6ES7134-6GB00-0BA1 | V1.0.0 | HSP0160 V13 SP1 or higher | HSP0227 V6.0 |
| | AI 4xU/I 2-wire ST | 6ES7134-6HD00-0BA1 | V1.1.0 | V13 Update 3 | HSP0227 V4.0 |
| | AI 2xU/I 2-/4-wire HF | 6ES7134-6HB00-0CA1 | V2.0.0 | HSP0161 V13 SP1 or higher | HSP0227 V6.0 V5.5 SP4 HF7 or higher |
| | AI 2xU/I 2-/4-wire HS | 6ES7134-6HB00-0DA1 | V2.0.1 | Integrated as of V14 | HSP0227 V5.0 |
| | AI Energy Meter 400VAC ST | 6ES7134-6PA01-0BD0 | V3.0.0 | V13 SP1 Update 4 HSP0159 | HSP0227 V6.0 |
| | AI Energy Meter 480VAC ST | 6ES7134-6PA20-0BD0 | V4.0.0 | V13 SP1 Update 4 HSP0159 | HSP0227 V6.0 V5.5 SP4 HF7 or higher |

| I/O module | | Order number | Firmware version | STEP 7 (TIA Portal) | STEP 7 V5.5 SP3 |
|-----------------------|-------------|--------------------|------------------|------------------------------|-----------------|
| Analog output modules | AQ 2xU ST | 6ES7135-6FB00-0BA1 | V1.0.0 | HSP0160 V13 SP1 or higher | HSP0228 V6.0 |
| | AQ 2xI ST | 6ES7135-6GB00-0BA1 | V1.0.0 | HSP0160 V13 SP1 or higher | HSP0228 V6.0 |
| | AQ 4xU/I ST | 6ES7135-6HD00-0BA1 | V1.1.0 | V13 Update 3 | HSP0228 V4.0 |
| | AQ 2xU/I HS | 6ES7135-6HB00-0DA1 | V2.0.1 | Integrated as of V14 | HSP0228 V5.0 |

2.6.1 Digital module device manuals

Manuals for I/O modules ST, BA

When you have deactivated all channels of the I/O module, a diagnostics alarm is still generated in the case of a fault if the "Missing supply voltage L+" diagnostics is enabled. For the following I/O modules, this behavior is corrected as of firmware version > V1.1.0:

- DI 16x24VDC ST
- DI 8x24VDC ST
- DQ 16x24VDC/0.5A ST
- DQ 8x24VDC/0.5 A ST
- DQ 4x24VDC/0.5A ST

Manuals for digital input modules with wire-break detection

When wire-break detection is configured the module requires a low quiescent current at the digital input in case of "0" signal for the monitoring. The parallel connection of a resistor with 25 k Ω to 45 k Ω is required in order that this quiescent current can flow when encoder contacts are open.

If wire-break detection is disabled in the configuration, no parallel connection of the resistor is required.

If wire-break detection is configured, connect a resistor with 25 k Ω to 45 k Ω parallel to each mechanical encoder contact.

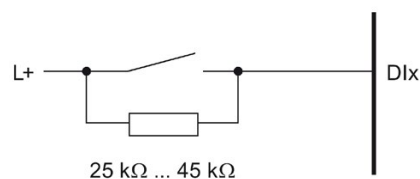

Figure 2-2 Connect mechanical encoder contact with resistor

Manuals DI 4x120...230VAC ST, Edition 02/2014; DQ 4x24...230VAC/2A ST, Edition 02/2014

Section 4.3 Address space

If you have enabled value status, the module returns value status 1, regardless of the state of the connected supply voltage.

Manual DI 8x24VDC HF, Edition 02/2014

Section 6.1 Technical specifications

- 24 V encoder supply
 - Output current, max.: 700 mA, total current

Manual DI 8xNAMUR HF, Edition 02/2014

Section A.2 Parameter assignment and structure of parameter data record

With data records 0 to 7, you can configure individual channels.

When the interface module IM 155-6 DP HF (PROFIBUS DP) is used and data records 0 and 1 are read, the module returns the diagnostics data records and not the parameter data records of the DI 8xNAMUR HF.

DQ 4x24VDC/2A HS manual, Edition 09/2016

Section 6.1 Technical specifications

For this module, the marine approval for the bridge and deck zone is valid from a bus cycle time of at least 250 μ s.

Manual DQ 4x24..230VAC/2A ST digital output module, Edition 03/2015

Section 3.1 Pin assignment; Supply voltage fuse protection

The module has neither short-circuit protection nor overload protection. Protect the module from being destroyed by impermissible high current and install a fine fuse in the supply line. The maximum rated current of the fine fuse depends on the hardware function status (FS) of the module.

| HW functional status of the module | Max. rated current of fuse | Tripping characteristic |
|------------------------------------|----------------------------|-------------------------|
| FS \leq 3 | 8 A | Quick response |
| FS \geq 4 | 10 A | Quick response |

Section 6.1 Technical specifications, Switching frequency with inductive load

The switching frequency of the outputs with inductive loads is max. 0.5 Hz.

Higher switching frequency is possible in spite of this, and depends on the alternating voltage and switched inductors or the power factor of the electric motor used.

| Alternating voltage | Condition | Max. switching frequency |
|---------------------|-----------------------------------------------------------------------------------------------------------------------------------------------------------------------------------------------------------------------------------------------------------------------------------------------------------------------------------------------------------------------------------|--------------------------|
| 200 VAC or lower | --- | 10 Hz |
| 200 VAC or higher | <ul style="list-style-type: none"> • Power factor of the electric motor $\cos \varphi > 0.35$ • Electric motor must only be turned off after startup (no jogging mode). <p>Electric motors which are turned off during startup could create inductive shutoff voltages > 600 V , which could destroy the output electronics (Triac).</p> | 10 Hz |

DQ 8x24VDC/0.5A ST manual, Edition 07/2014

Section 4.2 Explanation of the parameters (as of functional version FS-05 of DQ 8x24VDC/0.5A ST)

Diagnostics: Wire break:

The module responds to a wire break as follows:

- Disabled:
 - Channel status LED lit green
 - Output voltage present at channel
- Enabled:
 - Channel status LED is off
 - Output is switched off
 - In addition, the wire break diagnostics is signaled and the DIAG LED on the module flashes red

Note

If one of the two parameters "Diagnostics: Short-circuit to L+" or "Diagnostics: Wire break" is enabled and one of these diagnostics occurs, the affected channel is switched off. This prevents undefined load switching and supports detection of a faulty channel for module diagnostics.

DQ 4x24...230VAC/2A HF Manual, Edition 02/2018

Section 3.1.1. und 4.1.1 Wiring and block diagram

The following figure shows an example for the terminal assignment of the digital output module DQ 4x24...230VAC/2A HF on the BaseUnit BU type U0 (3-wire connection) in combination with a potential distribution module and terminal block.

For a 3-wire connection you connect the protective earth (PE) of the actuator to the terminal block.

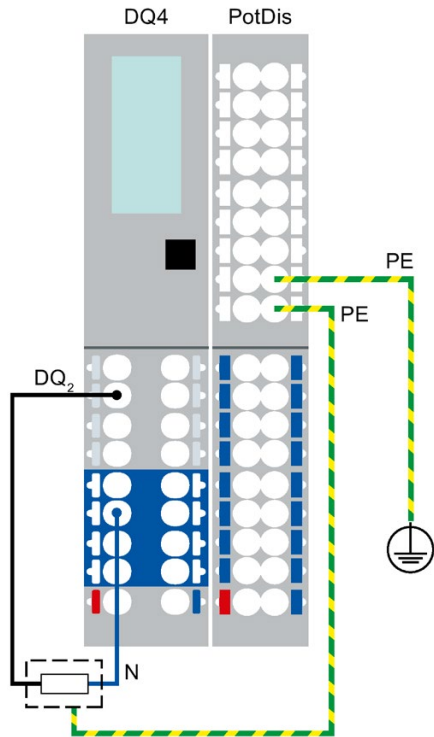

Figure 2-3 3-wire connection of actuators with potential distribution module at the digital output module DQ 4x24...230VAC/2A HF

RQ 4x24VUC/2A CO ST manual, Edition 02/2014

Section 4.3 Address space

Configuration options for the RQ 4x24VUC/2A CO ST digital output module:

The following configurations are possible:

- Configuration 1: without value status
- Configuration 2: with value status

Evaluating the value status:

An additional byte is allocated in the input address space if you enable the value status for the digital module. Each bit in this byte is assigned to a channel and returns information on the validity of the digital value (0 = incorrect value).

Address space for the RQ 4x24VUC/2A CO ST digital output module:

The following figure shows the assignment of the address space for the RQ 4x24VUC/2A CO ST with value status (Quality Information (QI)). The addresses for the value status are only available if the value status is enabled.

Assignment in the process image of the outputs (PIQ)

| | | | | | | | | | |
|------|---|---|---|---|---|---|---|---|----------------------------------|
| | 7 | 6 | 5 | 4 | 3 | 2 | 1 | 0 | |
| QB x | 0 | 0 | 0 | 0 | | | | | Output values at channels 0 to 3 |

Assignment in the process image of the inputs (PII)

| | | | | | | | | | |
|------|---|---|---|---|---|---|---|---|--------------------------------------|
| | 7 | 6 | 5 | 4 | 3 | 2 | 1 | 0 | |
| IB x | 0 | 0 | 0 | 0 | | | | | Value status (QI) at channels 0 to 3 |

0: value output at channel is faulty

Figure 2-4 Address space for the RQ 4x24VUC/2A CO ST digital output module

Section 6.1 Technical specifications

Correction / additions to the technical specifications:

- Switching capacity of the contacts (DC)
 - Rated switching voltage (DC): 24 V
 - With resistive load, max.: 2 A
 - Thermal continuous current, max.: 2 A
- Switching capacity of the contacts (AC)
 - Rated switching voltage (AC): 24 V
 - With resistive load, max.: 0.5 A
 - Thermal continuous current, max.: 0.5 A

**RQ 4x120VDC-230VAC/5A NO ST manual, Edition 03/2015 and
RQ 4x120VDC-230VAC/5A NO MA ST manual, Edition 12/2015**

Section 3.1 Wiring and block diagram

The AUX terminals of the self-assembling voltage bus can be used for the connection of the protective conductor (PE) or for voltages up to a maximum of 24 V DC.

2.6.2 Analog module device manuals

Manuals for analog input modules

| Manual | Edition |
|-----------------------------|----------------|
| AI 8xI 2-/4-wire BA | 03/2015 |
| AI 8xU BA | 03/2015 |
| AI 2xI 2-/4-wire ST | 12/2015 |
| AI 2xU ST | 12/2015 |
| AI 4xI 2-/4-wire ST | 07/2014 |
| AI 4xU/I 2-wire ST | 07/2014 |
| AI 4xI 2-wire 4...20mA HART | 11/2014 |
| AI 2xU/I 2-/4-wire HF | 12/2015 |
| AI 4xRTD/TC 2-/3-/4-wire HF | 02/2014 |
| AI 8xRTD/TC 2-wire HF | 02/2014 |

Section 5.2 Parameters

Note

Please note that the settings in the "Interference frequency suppression" parameter have a direct effect on the cycle time of the module. The analog value is therefore also affected by additionally set filtering via the "Smoothing" parameter.

Manuals AI 4xRTD/TC 2-/3-/4-wire HF, Edition 02/2014; AI 8xRTD/TC 2-wire HF, Edition 02/2014

Section 3 Wiring

Note

When potential-free sensors are used, the M- inputs can be bridged and connected to ground/FE. This is not necessary for disabled inputs.

Section 4.1 Measurement types and measuring ranges, figure 4-1, Assignment in the process image input (PII)

Assignment in the process image input (PII) with SIMATIC S7

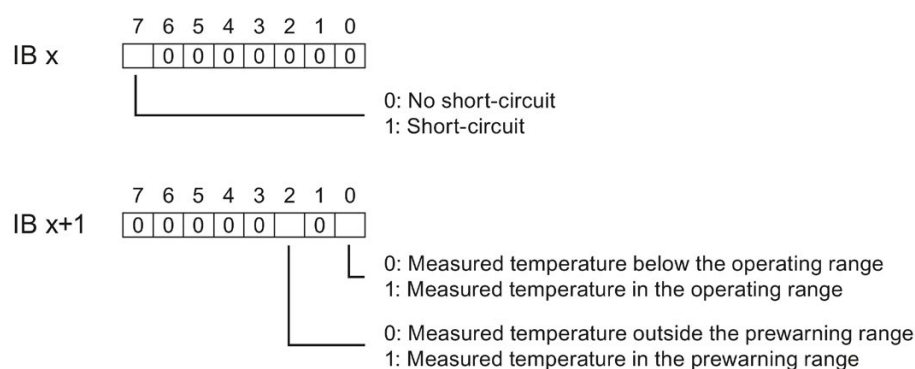

Figure 2-5 Assignment in the process image input (PII)

Manuals AI 4xRTD/TC 2-/3-/4-wire HF, Edition 02/2014; AI 8xRTD/TC 2-wire HF, Edition 02/2014; AQ 2xU/I HF, Edition 02/2014

Note

The "Channel temporarily not available" diagnostics is reported on a change to user calibration.

Other diagnostics alarms cannot be used to detect a change to user calibration.

Manuals AI 2xU/I 2-/4-wire HF, Edition 12/2015; AI Energy Meter 480VAC ST, Edition 12/2015

For configuration with STEP 7 V13 or higher (TIA Portal), real values between -7×10^{28} and $+7 \times 10^{28}$ can be input. This is true for configuration via HSP and via GSD file (PROFINET).

For configuration with STEP 7 V5.5 SP4 as of HF7, configuration by means of GSD file (PROFINET) with REAL values of -1.175×10^{38} to $+3.402 \times 10^{38}$ is possible.

With STEP 7 SP4 to HF6, parameter assignment of REAL values is not possible. Functions that require REAL values are not available in this case.

Manuals AI Energy Meter 400VAC ST, Edition 12/2015; AI Energy Meter 480VAC ST, Edition 12/2015

Requirements for the operation of the AI Energy Meter on slot 1 of the ET 200SP:

| Interface module / CPU | AI Energy Meter 400VAC ST (6ES7134-6PA01-0BD0) | AI Energy Meter 480VAC ST (6ES7134-6PA20-0BD0) |
|-------------------------------------------------|----------------------------------------------------------------------------------------------------------------|---------------------------------------------------|
| IM 155-6 PN BA (6ES7155-6AR00-0AN0) | Can be operated on slot 1 for all IM 155-6 PN BA | |
| IM 155-6 PN ST (6ES7155-6AU00-0BN0) | Can be operated on slot 1 for IM 155-6 PN ST from firmware version V3.1 and higher and functional status FS 07 | |
| IM 155-6 PN HF (6ES7155-6AU00-0CN0) | Can be operated on slot 1 for IM 155-6 PN HF from firmware version V3.0 and higher and functional status FS 05 | |
| IM 155-6 DP HF (6ES7 155-6BU00-0CN0) | Can be operated on slot 1 for IM 155-6 DP HF from firmware version V3.0 and higher | |
| CPU 1510SP-1 PN, CPU 1512SP-1 PN, CPU 1515SP PC | Can be operated on slot 1 for all CPUs | |

In the manual for Energy Meter 480VAC ST, Edition 12/2015

In the device manual for Energy Meter 480VAC ST, the measured value ID and the associated measured variables for the complete performance are reversed. The correct association is shown in the table below:

| Measured value ID | Measured variables | Unit |
|-------------------|-----------------------------|------|
| 34 | Total active power L1L2L3 | W |
| 35 | Total reactive power L1L2L3 | var |
| 36 | Total apparent power L1L2L3 | VA |
| 65 | Max. total active power | W |
| 66 | Max. total reactive power | var |
| 67 | Max. total apparent power | VA |
| 95 | Min. total active power | W |
| 96 | Min. total reactive power | var |
| 97 | Min. total apparent power | VA |

If you use the user-data mapping via data record DS 130, please note that the texts for the measured variables are also displayed incorrectly during configuration.

During configuration of the measured variables for the total active, reactive, and apparent power, select the following texts:

| Desired measured variable for the user-data mapping | Text to select during configuration |
|-----------------------------------------------------|---------------------------------------|
| Total active power L1L2L3 | Total apparent power L1L2L3 (ID00034) |
| Total reactive power L1L2L3 | Total active power L1L2L3 (ID00035) |
| Total apparent power L1L2L3 | Total reactive power L1L2L3 (ID00036) |
| Max. total active power | Max. total apparent power (ID00065) |
| Max. total reactive power | Max. total active power (ID00066) |
| Max. total apparent power | Max. total reactive power (ID00067) |
| Min. total active power | Min. total apparent power (ID00095) |
| Min. total reactive power | Min. total active power (ID00096) |
| Min. total apparent power | Min. total reactive power (ID00097) |

The project configuration modification described above is no longer required if the following tools and GSD files are used:

- STEP 7 (TIA Portal) as of V14
- STEP 7 (TIA Portal) as of V5.5 SP4 with HSP 0227
- GSD file GSDML-V2.32-ET200SP-20160706

Manual for AQ 2xU/I HF, Edition 02/2014

Section 3.1 Wiring and block diagram, pin assignment

You can now also use the 3-wire connection in addition to the 2-wire and 4-wire connection for the analog module AQ 2xU/I HF.

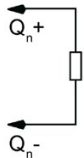
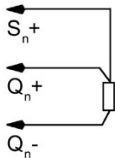
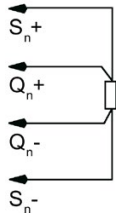
| Pin assignment for AQ 2xU/I HF | | | Explanation |
|------------------------------------------------------------------------------------------------------------------|------------------------------------------------------------------------------------------------------------------|------------------------------------------------------------------------------------------------------------------|----------------------------------------------------------------------------------------------------------------------------------------------------------------------------------------------------------------------------------------------------------------------------------|
| Voltage 2-wire connection  | Voltage 3-wire connection  | Voltage 4-wire connection  | <ul style="list-style-type: none"> • Qn+: Analog output voltage/current (positive), channel n • Qn-: Analog output voltage/current (negative), channel n • Sn+: Sensor line positive, channel n • Sn-: Sensor line negative, channel n |

The 3-wire connection and 4-wire connection make compensation for line impedance possible. The compensation is not possible for 2-wire connections due to the missing sensor cable.

2.6.3 Communications module manuals

Communication module CM DP, Edition 12/2014

The communication module CM DP supports the PROFIsafe protocol V2.
Exception: Fail-safe modules that only support PROFIsafe V1 mode.

2.6.4 Device manuals Technology modules

Technology module TM Pulse 2x24V, Edition 09/2015

Supplement in the section Preface

Please read the information about Open Source Software on the Internet (<https://support.industry.siemens.com/cs/ww/en/view/109740777>).

2.7 Function manuals

Function manual Cycle and response times, edition 09/2016

Section 3.4 Response time for cyclic and time-driven program processing,

Update time of the backplane bus for the CPUs ET 200SP (addendum to table 3-6 Update time of the ET 200SP CPUs)

The duration of the update time of the backplane bus for the ET 200SP CPUs depends on the number of I/O modules. The following table is for orientation purposes. It shows the approximate relationship between the number of I/O modules for the ET 200SP and the bus cycle used. The example in the table assumes there is 8 bytes of I/O data per I/O module.

| Number of ET 200SP I/O modules | Input data (bytes) | Output data (bytes) | Bus cycle used (µs) |
|--------------------------------|--------------------|---------------------|---------------------|
| 8 | 64 | 64 | 250 |
| 16 | 128 | 128 | 250 |
| 24 | 192 | 192 | 281.25 |
| 32 | 256 | 256 | 312.50 |
| 40 | 320 | 320 | 343.75 |
| 48 | 384 | 384 | 375 |
| 56 | 448 | 448 | 406.25 |
| 64 | 512 | 512 | 437.50 |

The bus cycle for I/O modules with more than 32 bytes of I/O data is calculated with an I/O module with 32 bytes. The I/O module requires additional bus cycles to update its I/O data in this case.