

SIEMENS

SIMATIC

ET 200SP Power Module F-PM-E 24VDC/8A PPM ST (6ES7136-6PA00-0BC0)

Manual

Preface

Documentation guide

1

Product overview

2

Connecting

3

Parameters/address space

4

Applications of the F-I/O
module

5

Interrupts/diagnostic
messages

6

Technical specifications

7

Response times

A

Switching of loads

B

Translation of original operating instructions



07/2013

A5E03857933-01

Legal information

Warning notice system

This manual contains notices you have to observe in order to ensure your personal safety, as well as to prevent damage to property. The notices referring to your personal safety are highlighted in the manual by a safety alert symbol, notices referring only to property damage have no safety alert symbol. These notices shown below are graded according to the degree of danger.

 DANGER
indicates that death or severe personal injury will result if proper precautions are not taken.
 WARNING
indicates that death or severe personal injury may result if proper precautions are not taken.
 CAUTION
indicates that minor personal injury can result if proper precautions are not taken.
NOTICE
indicates that property damage can result if proper precautions are not taken.

If more than one degree of danger is present, the warning notice representing the highest degree of danger will be used. A notice warning of injury to persons with a safety alert symbol may also include a warning relating to property damage.

Qualified Personnel

The product/system described in this documentation may be operated only by **personnel qualified** for the specific task in accordance with the relevant documentation, in particular its warning notices and safety instructions. Qualified personnel are those who, based on their training and experience, are capable of identifying risks and avoiding potential hazards when working with these products/systems.

Proper use of Siemens products

Note the following:

 WARNING
Siemens products may only be used for the applications described in the catalog and in the relevant technical documentation. If products and components from other manufacturers are used, these must be recommended or approved by Siemens. Proper transport, storage, installation, assembly, commissioning, operation and maintenance are required to ensure that the products operate safely and without any problems. The permissible ambient conditions must be complied with. The information in the relevant documentation must be observed.

Trademarks

All names identified by ® are registered trademarks of Siemens AG. The remaining trademarks in this publication may be trademarks whose use by third parties for their own purposes could violate the rights of the owner.

Disclaimer of Liability

We have reviewed the contents of this publication to ensure consistency with the hardware and software described. Since variance cannot be precluded entirely, we cannot guarantee full consistency. However, the information in this publication is reviewed regularly and any necessary corrections are included in subsequent editions.

Preface

Purpose of the documentation

This device manual complements the system manual ET 200SP distributed I/O system. General functions of the ET 200SP are described in the system manual ET 200SP distributed I/O system (<http://support.automation.siemens.com/WW/view/en/58649293>).

The information provided in this device manual and the system manual enables you to commission the ET 200SP distributed I/O system.

Conventions

Note the following identified notes:

Note

A note includes important information on the product described in the documentation, on handling the product or on the part of the documentation to which you should pay special attention.

Security information

Siemens provides automation and drive products with industrial security functions that support the secure operation of plants or machines. They are an important component in a holistic industrial security concept. With this in mind, our products undergo continuous development. We therefore recommend that you keep yourself informed with respect to our product updates. Please find further information and newsletters on this subject at: (<http://support.automation.siemens.com>)

To ensure the secure operation of a plant or machine it is also necessary to take suitable preventive action (e.g. cell protection concept) and to integrate the automation and drive components into a state-of-the-art holistic industrial security concept for the entire plant or machine. Any third-party products that may be in use must also be taken into account. Please find further information at: (<http://www.siemens.com/industrialsecurity>)

Table of contents

	Preface	3
1	Documentation guide	7
1.1	Documentation Guide for Power Module F-PM-E 24VDC/8A PPM ST	7
2	Product overview	9
2.1	Properties of the F-PM-E 24VDC/8A PPM ST	9
3	Connecting	13
3.1	Terminal assignment	13
3.2	Block diagram	16
4	Parameters/address space	17
4.1	Parameters	17
4.2	Explanation of parameters	19
4.2.1	F-parameters	19
4.2.2	PM-parameters	19
4.2.2.1	Maximum test period	19
4.2.3	Parameters of the sensor supply	20
4.2.3.1	Short circuit test	20
4.2.3.2	Time for short circuit test	20
4.2.3.3	Startup time of sensors after short circuit test	21
4.2.4	Parameters of the inputs	21
4.2.4.1	Sensor evaluation	21
4.2.4.2	Discrepancy behavior	23
4.2.4.3	Discrepancy time	24
4.2.4.4	Reintegration after discrepancy error	24
4.2.4.5	Activated	25
4.2.4.6	Sensor supply	25
4.2.4.7	Input delay	26
4.2.4.8	Pulse extension	26
4.2.4.9	Chatter monitoring	27
4.2.4.10	Monitoring window	28
4.2.5	Parameters of the output	28
4.2.5.1	Activated	28
4.2.5.2	Controlling the output	28
4.2.5.3	Output type	28
4.2.5.4	Max. readback time dark test	29
4.2.5.5	Disable dark test for 48 hours	31
4.2.5.6	Max. readback time switch on test	32
4.2.5.7	Activated light test	34
4.2.5.8	Diagnosis: Wire break	35
4.3	Address space	36

5	Applications of the F-I/O module	39
5.1	Applications for the output DQ/P1 and P2	39
5.1.1	Applications: Safety mode up to SIL3/Cat.4/PLe	40
5.1.1.1	Application: Wiring a load to the digital output, PM switching.....	40
5.1.1.2	Application: Wiring a load to the digital output, PP switching	41
5.1.1.3	Application: Wiring two loads in parallel to the digital output, PM switching.....	41
5.1.1.4	Application: Wiring two loads in parallel to the digital output, PP switching	42
5.2	Applications for inputs	43
5.2.1	Applications of the electronic module	43
5.2.2	Application 1: Safety mode SIL3/Cat.3/PLd.....	45
5.2.3	Application 2: Safety mode SIL3/Cat.3/PLe.....	48
5.2.4	Application 3: Safety mode SIL3/Cat.4/PLe.....	51
5.2.4.1	Application 3.1 (SIL3/Cat.4/PLe).....	52
5.2.4.2	Application 3.2 (SIL3/Cat.4/PLe).....	54
5.3	Application for internal evaluation	57
5.4	Applications for safety-related shutdown of standard modules	59
5.4.1	Safety-related shutdown of standard output modules, PM-switching.....	59
5.4.2	Safety-related shutdown of standard output modules, PP-switching	61
6	Interrupts/diagnostic messages.....	65
6.1	Status and error display	65
6.2	Interrupts	67
6.3	Diagnostic messages	69
6.4	Value status	75
7	Technical specifications	77
A	Response times	83
A.1	Response times	83
A.2	Minimum distance of test pulses.....	84
B	Switching of loads.....	85
B.1	Connecting capacitive loads	85
B.2	Switching of inductive loads.....	86

Documentation guide

1.1 Documentation Guide for Power Module F-PM-E 24VDC/8A PPM ST

Introduction

The documentation of the SIMATIC products has a modular design and includes topics concerning your automation system.

The complete documentation of the ET 200SP system consists of different modules divided into system manuals, function manuals and manuals.

The STEP 7 (online help) information system supports you in configuring and programming your automation system.

Overview of documentation for the F-PM-E 24VDC/8A PPM ST fail-safe power module

The table below lists additional documents that complement this description of the F-PM-E 24VDC/8A PPM ST fail-safe power module and are available on the Internet.

Table 1- 1 Documentation for the F-PM-E 24VDC/8A PPM ST fail-safe power module

Topic	Documentation	Most important contents
Description of the system	System manual ET 200SP distributed I/O system (http://support.automation.siemens.com/WW/view/en/58649293)	<ul style="list-style-type: none"> • Application planning • Installation • Connecting • Commissioning • Approvals • TÜV certificate
BaseUnits	Manual ET 200SP BaseUnits (http://support.automation.siemens.com/WW/view/en/58532597/133300)	Technical specifications
Description of the SIMATIC Safety F-system	Programming and operating manual SIMATIC Safety - Configuring and Programming (http://support.automation.siemens.com/WW/view/en/54110126)	<ul style="list-style-type: none"> • Configuring • Programming • Approvals

SIMATIC manuals

The latest manuals for SIMATIC products are available on the Internet (<http://www.siemens.com/automation/service&support>) for free download.

Functional Safety Services

Siemens Functional Safety Services support you with a comprehensive package of services from risk assessment to verification all the way to plant commissioning and modernization. We also offer consultation on the use of fail-safe and fault-tolerant SIMATIC S7 automation systems.

You will find more detailed information on the Internet (<http://www.siemens.com/safety-services>).

Please send your questions to us by e-mail (<mailto:safety-services.industry@siemens.com>).

Product overview

2.1 Properties of the F-PM-E 24VDC/8A PPM ST

Order number

6ES7136-6PA00-0BC0

View of the module

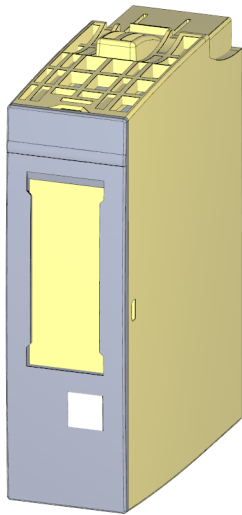

Figure 2-1 View of the F-PM-E 24VDC/8A PPM ST module

Properties

- Technical properties
 - Fail-safe digital module
 - 2 inputs (SIL3/Cat.4/PLe)
 - 1 output PM-switching or PP-switching, output current 8 A (SIL3/Cat.4/PLe)
 - 2 outputs for sensor supply
 - Sink input (P-reading)
 - Source output (PM/PP-switching)
 - Supply voltage L+
 - Suitable for connection of 2-wire sensors to IEC 61131, type 1
 - Channel-specific assignable input delay 0.4 ms to 20 ms
 - Diagnostic display (DIAG red/green LED)
 - Status display for each input or output (green LED)
 - Fault display for each input or output (red LED)
 - Diagnostics, e.g., short circuit/wire break, channel-specific
 - Diagnostics, e.g., load voltage missing, module-specific
 - Channel-specific or passivation throughout the module
- Supported functions
 - Firmware update
 - I&M identification data
 - PROFIsafe

 **WARNING**

The fail-safe performance characteristics in the technical specifications apply to a proof-test interval of 20 years and a mean time to repair of 100 hours. If a repair within 100 hours is not possible, remove the respective module from the BaseUnit or switch off its supply voltage before 100 hours expires. The module switches off independently after the 100 hours have expired.

Follow the repair procedure described in section Diagnostic messages (Page 69).

Accessories

The following accessories, which are not included in the product package of the F-module, can be used with the F-module:

- Labeling strips
- Color identification labels
- Reference identification labels
- Shield connection

Additional information on accessories can be found in the ET 200SP Distributed I/O System System Manual (<http://support.automation.siemens.com/WW/view/en/58649293>).

Safety-related shutdown of standard DQ modules by the F-PM-E 24VDC/8A PPM ST

This cost-effective solution allows for full and simultaneous shutdown of all affected outputs of the standard DQ modules when a fault is detected in the process or on the F-PM-E 24VDC/8A PPM ST power module.

You achieve SIL2/Cat.3/PLd with safety-related shutdown of standard DQ modules.

You can use the F-PM-E 24VDC/8A PPM ST power module with all standard DQ modules within a potential group. Additional information is available in Applications for safety-related shutdown of standard modules (Page 59).

Passivation of fail-safe outputs over a long period of time

 WARNING
Unintentional activation of F-I/O with fail-safe outputs
If an F-I/O with fail-safe outputs is passivated for a period longer than that specified in the safety parameters (> 100 hours) and the fault remains uncorrected, you need to exclude the possibility that the F-I/O can be activated unintentionally by a second fault, and thus place the F-system in a dangerous state.
Even though it is highly unlikely that such hardware faults occur, you must prevent the unintentional activation of F-I/O with fail-safe outputs by using circuit measures or organizational measures.
One possibility is the shutdown of the power supply of the passivated F-I/O within a time period of 100 hours, for example.
The required measures are standardized for plants with product standards.
For all other plants, the plant operator must create a concept for the required measures and have it approved by the inspector.

Connecting

3.1 Terminal assignment

General terminal assignment

Table 3- 1 Terminal assignment for F-PM-E 24VDC/8A PPM ST

Terminal assignment for F-PM-E 24VDC/8A PPM ST (6ES7136-6PA00-0BC0)						
Terminal	Assignment	Terminal	Assignment	Description	BaseUnit ¹	Color identification label (terminals 1 to 16)
1	DI ₀	2	DI ₁	<ul style="list-style-type: none"> DI_n: Input signal, channel n VS_n: Internal sensor supply, channel n DQ-P₀: Output signal, channel 0, P-switching DQ-M₀: Ground for output signal, channel 0, M-switching AUX: Protective conductor connection or voltage bus for SELV/PELV circuits 	C0	 <p>CC52 6ES7193-6CP52-2MC0</p>
3	VS ₀	4	VS ₁			
5	DQ-P ₀	6	DQ-M ₀			
7	AUX	8	AUX			
L+	DC24V	N	M			
L+	DC24V	N	M			

¹ Usable BaseUnit types can be identified by the last two digits of their order number. See also *ET 200SP Distributed I/O System* manual

Note

Make sure that you only use the power module with BaseUnit type C0 during commissioning.

Digital output

The digital output switches the voltage L+ and M using two electronic switches (see Block diagram (Page 16)). The switched voltage and chassis are conducted to the internal voltage buses P1 and P2. The switched voltage and chassis is also available at the BaseUnit at DQ-P₀ and DQ-M₀.

This results in two connection options that can be used at the same time, if desired:

- One load can be wired directly to the BaseUnit (see Applications for the output DQ/P1 and P2 (Page 39)).
- The standard modules can be supplied and switched off safety-related by means of the internal voltage buses P1 and P2. You can, in turn, connect loads to the standard modules (see Applications for safety-related shutdown of standard modules (Page 59)).

WARNING

It is no longer possible to shut down an actuator if a cross circuit has developed between L+ and DQ. To prevent cross circuits between L+ and DQ, you must route the cables used to connect the actuators in a cross-circuit proof manner (for example, as separate, sheathed cables or in separate cable ducts).

Redundant ground conductor required

WARNING

The ground conductor to the BaseUnit for F-PM-E 24VDC/8A PPM ST must be installed twice for safety reasons. Any interruption of a single ground conductor would prevent the safety-related shutdown of voltage bus P2.

Property of the individual shutdown of F-modules with fail-safe outputs

A channel-specific shutdown occurs when a fault is detected. It is also possible to react to critical process states staggered over time or to perform safety-related shutdown of individual outputs.

Switching of loads with ground if the F-module is configured PM-switching

If the following two conditions are met, F-PM-E 24VDC/8A PPM ST detects a short circuit:

- If loads that have a connection between chassis and ground are switched by the F-PM-E 24VDC/8A PPM ST, for example, to improve the EMC properties.
- If chassis and ground are connected at the power supply unit.

From the perspective of the F-module, the M-switch is bridged by the chassis-ground connection (refer to the diagram below as an example for an F-PM-E 24VDC/8A PPM ST).

Remedy:

- Use the F-PM-E 24VDC/8A PPM ST configured as a PP-switching module.
- Increase the value of the resistance between chassis and ground at the load end to more than 100 k Ω .
- Reduce the capacitance value between chassis and ground at the load end to less than 2 μ F.

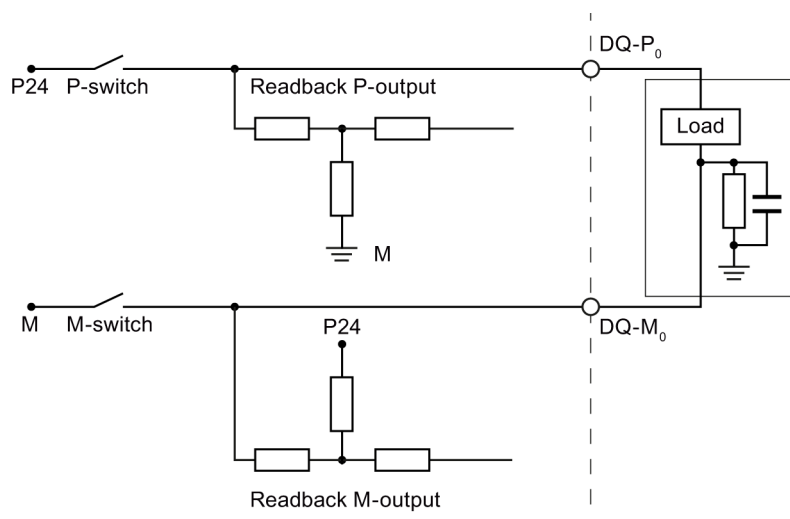

Figure 3-1 Switching of grounded loads (resistance between chassis and ground)

! WARNING

During startup, the F-PM-E 24VDC/8A PPM ST carries out a switch-on test of approximately 3 ms. The capacitance between chassis and ground at the load end is charged by way of the load resistance. This low charging current may briefly trigger sensitive load circuits.

See also

ET 200SP distributed I/O system

(<http://support.automation.siemens.com/WW/view/en/58649293>)

3.2 Block diagram

Block diagram

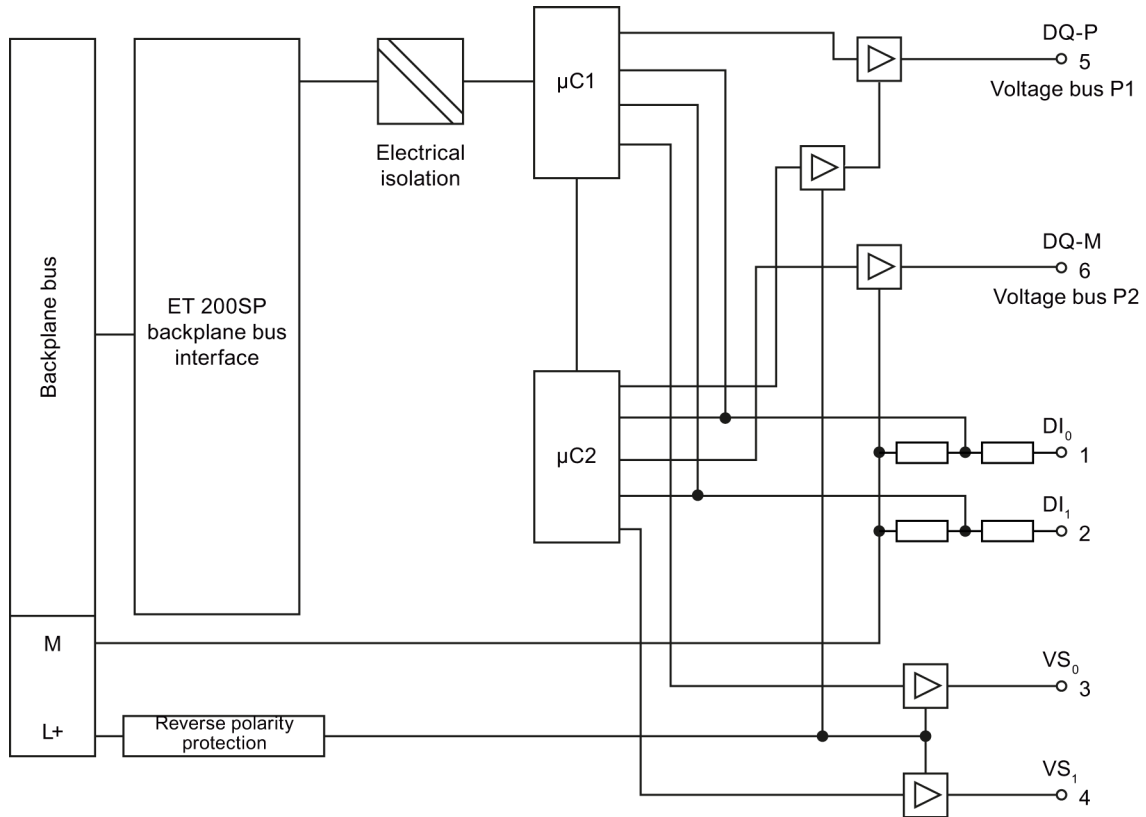

Figure 3-2 Block diagram F-PM-E 24VDC/8A PPM ST

Parameters/address space

4.1 Parameters

Parameters

 WARNING
Diagnostic functions should be activated or deactivated in accordance with the application.

Table 4- 1 Parameters for power module

Parameter	Value range	Parameter reassignment in RUN	Scope
F-parameters:			
Manual assignment of the F-monitoring time	<ul style="list-style-type: none"> disable enable 	no	Module
F-monitoring time	1 to 65535 ms	no	Module
F-source address	1 to 65534	no	Module
F-destination address	1 to 65534	no	Module
F-parameter signature (without address)	0 to 65535	no	Module
Behavior after channel faults	<ul style="list-style-type: none"> Passivate entire module Passivate channel 	no	Module
F-I/O DB manual number assignment	<ul style="list-style-type: none"> disable enable 	no	Module
F-I/O DB number	—	no	Module
F-I/O DB name	—	no	Module
PM-parameters:			
Maximum test period	<ul style="list-style-type: none"> 100 s 1000 s 	no	Module
Sensor supply:			
Short circuit test	<ul style="list-style-type: none"> disable enable 	no	Channel
Time for short circuit test	0.5 ms to 2 s	no	Channel
Startup time of the sensors after short circuit test	0.5 ms to 2 s	no	Channel

4.1 Parameters

Parameter	Value range	Parameter reassignment in RUN	Scope
Inputs:			
Sensor evaluation	<ul style="list-style-type: none"> 1oo1 evaluation 1oo2 evaluation, equivalent 1oo2 evaluation, non-equivalent 	no	Channel pair
Discrepancy behavior	<ul style="list-style-type: none"> Supply last valid value Supply 0 value 	no	Channel pair
Discrepancy time	5 ms to 30 s	no	Channel pair
Reintegration after discrepancy error	<ul style="list-style-type: none"> Test 0-signal necessary Test 0-signal not necessary 	no	Channel pair
Activated	<ul style="list-style-type: none"> disable enable 	no	Channel
Sensor supply	<ul style="list-style-type: none"> Sensor supply 0 Sensor supply 1 External sensor supply 	no	Channel
Input delay	<ul style="list-style-type: none"> 0.4 ms 0.8 ms 1.6 ms 3.2 ms 6.4 ms 10.0 ms 12.8 ms 20 ms <p>The provided value range depends on the parameter assignment of the employed sensor supply.</p>	no	Channel
Pulse extension	<ul style="list-style-type: none"> — 0.5 s 1 s 2 s 	no	Channel
Chatter monitoring activated	<ul style="list-style-type: none"> disable enable 	no	Channel
Number of signal changes	2 to 31	no	Channel
Monitoring window	0 to 100 s (If 0 s is configured, the monitoring window is 0.5 s long.)	no	Channel

Parameter	Value range	Parameter reassignment in RUN	Scope
Output:			
Activated	<ul style="list-style-type: none"> • disable • enable 	no	Channel
Control of the output	<ul style="list-style-type: none"> • F-CPU • F-CPU and onboard F-DI 	no	Module
Output type	<ul style="list-style-type: none"> • PM switching • PP switching 	no	Channel
Max. readback time dark test	0.8 to 400.0 ms	no	Channel
Disable dark test for 48 hours	<ul style="list-style-type: none"> • disable • enable 	no	Channel
Max. readback time switch on test	0.8 to 5.0 ms	no	Channel
Activated light test	<ul style="list-style-type: none"> • disable • enable 	no	Channel
Diagnosis: Wire break	<ul style="list-style-type: none"> • disable • enable 	no	Channel

4.2 Explanation of parameters

4.2.1 F-parameters

F-parameters

Information on F-parameters is available in the SIMATIC Safety - Configuring and Programming (<http://support.automation.siemens.com/WW/view/en/54110126>) manual.

4.2.2 PM-parameters

4.2.2.1 Maximum test period

Here you specify the time within which the light and dark tests (in all combinations) should be performed throughout the module. When this time expires, the tests are repeated.

The "Maximum test period" parameter is a module parameter, which means the test cycle for the entire fail-safe output module is performed within the configured maximum test time. If the bit pattern test is not performed within the configured time (or the shortened test time of 60 seconds in case of an error), the module goes into the error state.

4.2.3 Parameters of the sensor supply

4.2.3.1 Short circuit test

Here you enable the short-circuit detection for the channels of the F-module for which "Internal sensor supply" is set.

The short-circuit test is only useful if you are using simple switches that do not have their own power supply. For switches with power supply, for example, 3/4-wire proximity switches, a short-circuit test is not possible.

The short-circuit detection switches off the sensor supply briefly. The length of the deactivation period is equivalent to the configured "Time for sensor test".

If a short-circuit is detected, the F-module triggers a diagnostic interrupt and the input is passivated.

The following short-circuits are detected:

- Short-circuit of input to L+
- Short-circuit of the input of another channel when it has a 1 signal
- Short-circuit between the input and sensor supply of another channel
- Short-circuit between the sensor supply and the sensor supply of another channel

If the short-circuit test is disabled, you must make your wiring short-circuit and cross-circuit proof or select a connection type (discrepancy, non-equivalent) which also detect the cross-circuits using discrepancy.

During the execution time (Time for sensor test + Startup time of sensor after sensor test) of the short circuit test, the last valid value of the input before the start of the short circuit test is passed to the F-CPU. The activation of the short-circuit test thus affects the response time of the respective channel or channel pair.

4.2.3.2 Time for short circuit test

Function

When the short-circuit test is enabled, the corresponding sensor supply is switched off for the configured time. If the module does not detect a "0" signal at the input within the assigned time, a diagnostic message is generated.

When assigning parameters, note that

- If the channel is passivated, this may be due to too high capacitance between sensor supply and input. This consists of the capacitance per unit length of the cable and the capacitance of the employed sensor. If the connected capacitance does not discharge within the assigned time, you need to adjust the "Time for sensor test" parameter.
- The values available for the input delay depend on the "Ramp-up time of the sensor after short-circuit test" and the "Time for short-circuit test" of the configured sensor supply.

4.2.3.3 Startup time of sensors after short circuit test

Function

In addition to the off time ("Time for sensor test"), a startup time must be specified for performing the short circuit test. You use this parameter to notify the module how long the utilized sensor needs to start up after connecting the sensor supply. This prevents an undefined input state due to transient reactions in the sensor.

When assigning parameters, note that

- This parameter must be greater than the transient recovery time of the employed sensor.
- Because the assigned time affects the response time of the module, we recommend that you set the time as short as possible but long enough so that your sensor can settle safely.
- The values available for the input delay depend on the "Ramp-up time of the sensor after short-circuit test" and the "Time for short-circuit test" of the configured sensor supply.

Requirement

The short circuit test is enabled.

4.2.4 Parameters of the inputs

4.2.4.1 Sensor evaluation

Overview

Select the type of sensor evaluation with the "Sensor evaluation" parameter:

- 1oo2 evaluation, equivalent
- 1oo2 evaluation, non-equivalent

1oo2 evaluation equivalent/non-equivalent

With a 1oo2 evaluation equivalent/non-equivalent, two input channels are occupied by:

- One single-channel sensor
- One non-equivalent sensor
- One two-channel sensor
- Two single-channel sensors

The input signals are compared internally for equivalence or non equivalence.

Note that in 1oo2 evaluation, two channels are combined into a channel pair. The number of available process signals of the F-module is reduced accordingly.

Discrepancy analysis

When using a two-channel sensor or two single-channel sensors which measure the same process variable, the sensors interact with a slight time delay due to the limited precision of their arrangement.

The discrepancy analysis for equivalence/non-equivalence is used for fail-safe applications to prevent errors from time differences between two signals for the same function. The discrepancy analysis is initiated when different levels are detected in two associated input signals (when testing for non-equivalence: the same levels). A check is made to determine whether the difference in levels (when testing for non equivalence: the same levels) has disappeared after an assignable time period, the so-called discrepancy time. If not, this means that a discrepancy error exists.

Achievable safety class

The following safety class can be achieved depending on the selected sensor evaluation:

- SIL3/Cat.4/PLe with "1oo2 evaluation equivalent/non-equivalent"

4.2.4.2 Discrepancy behavior

Function

For the "Discrepancy behavior", you assign the value that is supplied to the safety program in the F-CPU during a discrepancy between two relevant input channels, which means while discrepancy time is running. You assign the discrepancy behavior as follows:

- "Supply last valid value"
- "Supply value 0"

Requirements

You have assigned the following:

- "Evaluation of the sensors": "1oo2 evaluation, equivalent" or "1oo2 evaluation, non-equivalent"

"Supply last valid value"

The most recent valid value (old value) before the discrepancy occurred is made available to the safety program in the F-CPU as soon as a discrepancy is detected between the signals of the two affected input channels. This value is supplied until the discrepancy disappears or the discrepancy time expires and a discrepancy error is detected. The sensor-actuator response time is correspondingly increased by this time.

This means the discrepancy time of connected sensors with 1oo2 evaluation must be adjusted to fast response times. It makes no sense, for example, if connected sensors with a discrepancy time of 500 ms trigger a time-critical shutdown.. In the worst-case scenario, the sensor-actuator response time is extended by an amount approximately equal to the discrepancy time:

- For this reason, position the sensors in the process in such a way as to **minimize discrepancy**.
- Then select the **shortest possible** discrepancy time which is also sufficient to compensate for faulty triggering of discrepancy errors.

"Supply value 0"

As soon as a discrepancy between the signals of the two relevant input channels is detected, the value "0" is made available to the safety program in the F-CPU.

If you have set "Supply value 0", the sensor-actuator response time is not affected by the discrepancy time.

4.2 Explanation of parameters

4.2.4.3 Discrepancy time

Function

You can set the discrepancy time for each channel pair.

Requirements

You have assigned the following:

- "Evaluation of the sensors": "1oo2 evaluation, equivalent" or "1oo2 evaluation, non-equivalent"

In most cases, a discrepancy time is started, but does not fully expire because the signal differences are cleared within a short time.

Set the discrepancy time high enough that in the error-free case the difference between the two signals (when testing for non equivalence: the same levels) has always disappeared before the discrepancy time has expired.

Behavior while discrepancy time is running

While the programmed discrepancy time is running internally on the module, either the **last valid value** or "**0**" is returned to the safety program on the F-CPU by the input channels involved, depending on the parameter settings for the behavior at discrepancy.

Behavior after expiration of the discrepancy time

If no agreement (when checking for non equivalence: inequality) of the input signals exists once the assigned discrepancy time expires, for example, due to a break in a sensor wire, a discrepancy error is detected and the "Discrepancy error" diagnostic message containing information on which channels are faulty is generated.

4.2.4.4 Reintegration after discrepancy error

Function

This parameter specifies the criteria for when a discrepancy error is regarded as corrected, thus enabling reintegration of the relevant input channels. The following parameter assignment options are available:

- "Test 0-signal necessary"
- "Test 0-signal not necessary"

Requirements

You have assigned the following:

- "Sensor evaluation": "1oo2 evaluation, equivalent" or "1oo2 evaluation, non equivalent"

"Test 0-signal necessary"

If you have assigned "Test 0-signal necessary", a discrepancy error is not regarded as corrected until a 0-signal is present at both of the relevant input channels.

If you are using non equivalent sensors, which means you have set "Sensor evaluation" to "1oo2 evaluation, non equivalent", a 0-signal must be present again at the low order channel of the channel pair.

"Test 0-signal not necessary"

If you have assigned "Test 0-Signal not necessary", a discrepancy error is regarded as corrected when a discrepancy no longer exists at both of the relevant input channels.

4.2.4.5 Activated

You hereby enable the corresponding channel for signal processing in the safety program.

4.2.4.6 Sensor supply

Here you select one of the internal sensor supplies VS_0 to VS_n or an external sensor supply.

The selection of an internal sensor supply is required for using the short circuit test.

See also

Time for short circuit test (Page 20)

4.2 Explanation of parameters

4.2.4.7 Input delay

Function

To suppress stray interference, you can set an input delay for the entire channel or channel pair.

Interference pulses whose pulse time is less than the set input delay (in ms) are suppressed. Suppressed interference pulses are invisible in the PII.

A high input delay suppresses longer interference pulses, but results in a longer response time.

The values available for the input delay depend on the "Startup time of sensors after short circuit test" and the "Time for short circuit test" of the configured sensor supply.

Note

Due to the physical properties, there is a possibility of crosstalk between signals in the case of long, unshielded signal lines (see section "Electromagnetic compatibility" in the system manual ET 200SP distributed I/O system

(<http://support.automation.siemens.com/WW/view/en/58649293>)).

Adapt the input delay or use shielded signal lines in order to prevent possible passivation of the fail-safe digital inputs and switch-off of the sensor supply.

See also

Technical specifications (Page 77)

4.2.4.8 Pulse extension

Function

Pulse extension is a function to change a digital input signal. A pulse on a digital input is extended to at least the assigned length. If the input pulse is already longer than the assigned length, the pulse is not changed.

The fail-safe electronic module only lengthens pulses with the value "0" because the basis of the safety concept is that there is a safe state for all process variables. For digital F-I/O, this is the value "0", which applies to sensors as well as to actuators.

With 1oo2 evaluation, the result of the evaluation of both sensors is used for the pulse extension.

4.2.4.9 Chatter monitoring

Function

Chatter monitoring is a process control function for digital input signals. It detects and reports unusual signal sequences in the process with 1oo1 evaluation, for example, an input signal fluctuating between "0" and "1" too frequently. The occurrence of such signal characteristics is an indication of faulty sensors or process control instability.

Recognizing unusual signal patterns

An assigned monitoring window is available for each input channel. The monitoring window starts with the first signal change of the input signal. If the input signal changes within the monitoring window at least as often as the assigned "Number of signal changes", a chatter error is detected. If no chatter error is detected within the monitoring window, the next signal change restarts the monitoring window.

If a chatter error is detected, a diagnostic is signaled. If the chatter error does not occur for the monitoring window for three times the configured period, the diagnostic is reset.

Principle

The figure below shows the principle of chatter monitoring as a graphic.

Parameter for number of signal changes = 8

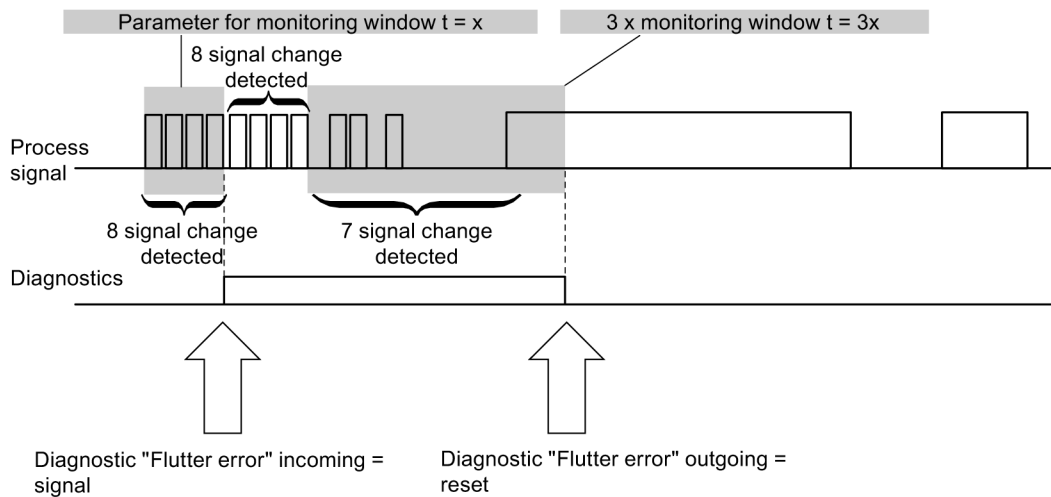

Figure 4-1 Figure chatter monitoring

Number of signal changes

Sets the number of signal changes after which a chatter error should be reported.

4.2 Explanation of parameters

4.2.4.10 Monitoring window

Sets the time for the monitoring window of flutter monitoring.

You can set times of 1 s to 100 s in whole seconds for the monitoring window.

You can configure a monitoring window of 0.5 s when you set 0 s.

4.2.5 Parameters of the output

4.2.5.1 Activated

If you select this check box, the corresponding channel is enabled for signal processing in the safety program.

You can deactivate an unused channel with this parameter.

4.2.5.2 Controlling the output

Activates the internal evaluation.

Additional information on internal evaluation is available in the chapter "Application for internal evaluation" (Page 57).

4.2.5.3 Output type

The parameter specifies if the output switches PM or PP.

4.2.5.4 Max. readback time dark test

Function

Dark tests are shutdown tests with bit pattern test.

For a dark test, a test signal is switched to the output channel while the output channel is active (output signal "1"). This output channel is then briefly disabled (= "dark period") and read back. A sufficiently slow actuator does not respond to this and remains switched on.

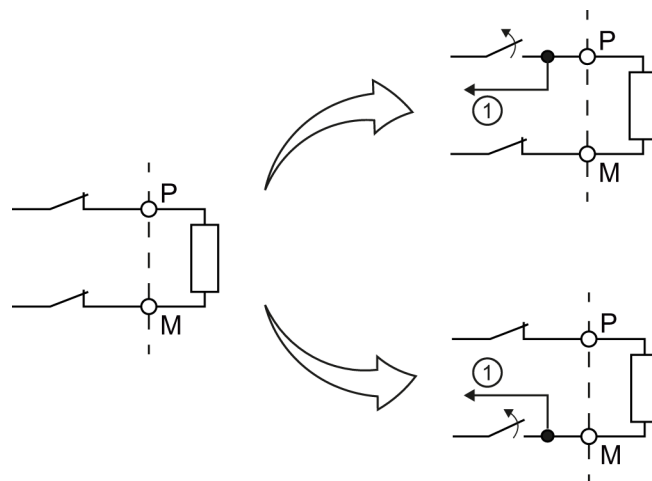

① Readback

Figure 4-2 Functional principle of the dark test (PM switching)

This parameter allows you to set the time for the readback.

If the expected signals (P-readback and M-readback) could not be read back correctly after expiration of the readback time dark test, the output channel is passivated.

No new process values are switched to the output channels while a bit pattern is still active (switch test is carried out). This means that a higher maximum readback time for the dark test increases the response time of the F-module.

WARNING

Through the configured readback time dark test, short circuits (cross-circuits) to a signal with a frequency greater than $1/(2 \times \text{configured readback time dark test})$ Hz cannot be recognized (50:50 sampling ratio).

Short circuits (cross-circuits) to an output of the same module are recognized.

The parameter also has an effect on the short circuit detection (cross-circuit) with "1" signal when the output signal is changed from "1" to "0" with the safety program.

Setting readback time dark test

Because the fault reaction time is extended by the length of the readback time dark test, we recommend that you set the readback time dark test by trial and error as low as possible, but high enough that the output channel is not passivated.

You determine the readback time required for your actuator with the diagram in the chapter Switching capacitive loads (Page 85).

If the capacity of the actuator is not known, it may be necessary for you to determine the value for the readback time light test by trial and error. This may also be necessary due to the part variances in the actuator or external influences.

Proceed as follows:

- Set the readback time dark test so that the output channel can be read back correctly but your actuator does not respond yet.
- If the output channel is passivated sporadically, set a higher value for the maximum readback time dark test.
- If the output channel is passivated, the readback time dark test is too small for a connected capacitive load. The discharge cannot take place during the configured readback time dark test. Increase the readback time dark test.

If you have set the readback time dark test to the maximum value of 400 ms and there is still a passivation of the output channel, there is either an external fault or the connected capacity is outside the permitted range.

Test pulses of the dark test

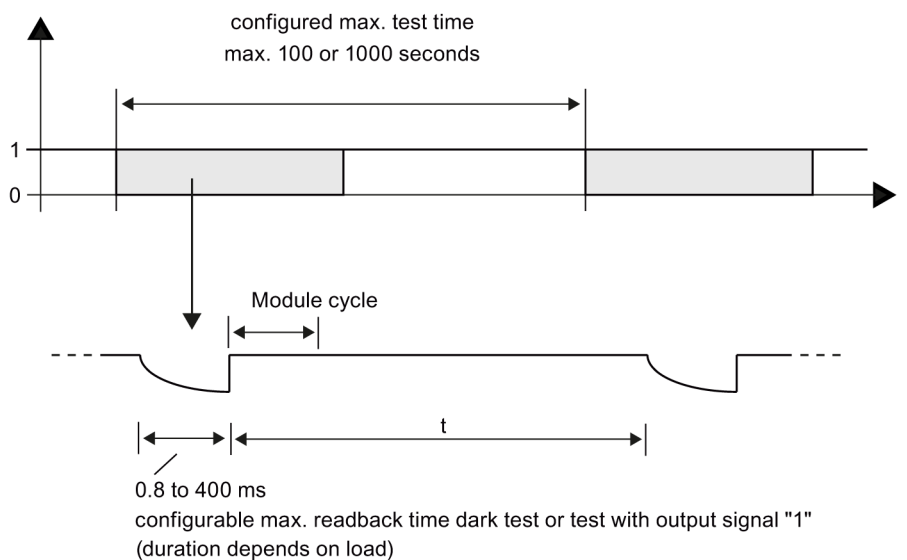

Figure 4-3 Test pulses of the dark test

The distance between two test pulses (t) depends on the parameter assignment. Additional information is available in Minimum distance of test pulses (Page 84).

4.2.5.5 Disable dark test for 48 hours

This option allows you to suppress the dark test.

If the channel is permanently active (1) for 48 hours, 2 dark test pulses (PP switching) or 3 dark test pulses (PM switching) are directed to this channel once the time has expired.

You must provide the signal change from 1 to 0 at the channel yourself within 48 hours to prevent the dark test pulse. The dark test is suspended for another 48 hours after the signal change from 0 to 1.

The dark test is permanently suppressed if the following condition is met:

- A signal change from 1 to 0 takes place before the 48 hours have expired.

WARNING

The output is passivated if an error caused by a short-circuit is recognized when the safety-function is executed (output turned off). This is necessary because a complete bit pattern test is not performed within 48 hours, which means an undetected error burst may not be ruled out.

If the channel can retain signal 0 for 48 hours and longer, the function "Disable dark test for 48 hours" must not be used.

Consult the respective requirements of your product standards regarding error detection time.

4.2.5.6 Max. readback time switch on test

Function

The switch on test is part of the bit pattern test.

During the switch on test, the P-switch and M-switch of the output channel are alternately closed and read back when the output channel is inactive (output signal "0"). Contrary to the light test, no power flows through the connected load during the switch on test.

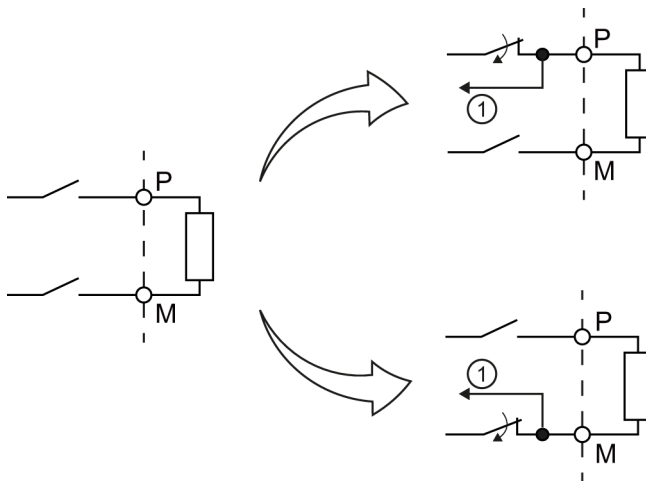

① Readback

Figure 4-4 Functional principle of the switch on test (PM switching)

This parameter allows you to set the time for the readback. If the signal was not read back correctly once the time has expired, the output channel is passivated.

The switch on test detects the following faults:

- Short circuit to L+ with output signal "0"
- Short circuit to ground with output signal "0"

<p>⚠ WARNING</p> <p>Through the configured readback time, short circuits (cross-circuits) to an interfering signal with a frequency $> 1 / (2 \times \text{configured readback time})$ Hz can be suppressed (50:50 sampling ratio).</p> <p>Short circuits (cross-circuits) to an output of the same module are recognized.</p>

Setting readback time

Because the fault reaction time is extended by the length of the set readback time, we recommend that you set the readback time by trial and error as low as possible but high enough that the output channel is not passivated.

To determine the readback time required for your actuator, refer to the diagram in the chapter Switching capacitive loads (Page 85).

If the capacity of the actuator is not known, it may be necessary for you to determine the required value for the readback time by trial and error. This may also be necessary due to the part variances in the actuator or external influences.

Proceed as follows:

- Set the readback time switch on test in such a way that the output channel can be read back correctly but your actuator does not respond yet.
- If the output channel is passivated sporadically, set a higher value for the maximum readback time switch on test.
- If the output channel is passivated, the readback time switch on test is too small for a connected capacitive load. The charge of the capacitive load cannot take place within the configured readback time switch on test. Increase the readback time.

If you have set the readback time to the maximum value of 5 ms and there is still a passivation of the output channel, there is either an external fault or the connected capacity is outside the permitted range.

4.2.5.7 Activated light test

Function

Overload and wire break are detected with a 0 signal at the output.

For a light test, several test signals are switched to the output channel while the output channel is inactive (output signal "0"). The output channel is switched on briefly during the light test (= "light period") and read back. A sufficiently slow actuator does not respond to this and remains switched off.

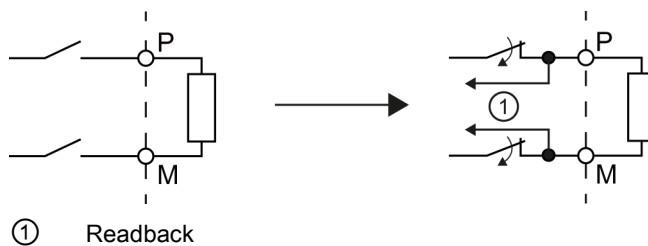

① Readback

Figure 4-5 Functional principle of the light test (PM switching)

In contrast to the switch on test, the P-switch and the M-switch switch at the same time during the light test and power flows through the connected load.

If the readback signals are incorrect, the signal is present for the configured readback time at the output channel before the fault causes passivation of the output channel.

If the signal was not read back correctly once the maximum readback time switch on test has expired, the output channel is passivated.

No new process values are switched to the output channels while a bit pattern is still active (switch test is carried out). This means that a higher maximum readback time switch on test for the light test increases the response time of the F-module.

Test pulses of the light test

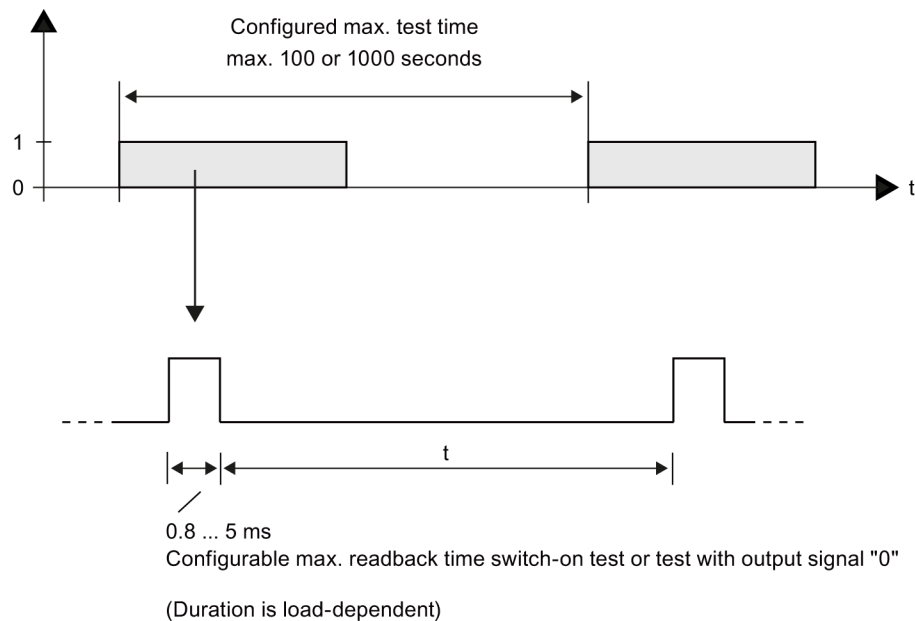

Figure 4-6 Test pulses of the light test

The distance between two test pulses (t) depends on the parameter assignment. Additional information is available in Minimum distance of test pulses (Page 84).

If a light pulse returns a fault, the same light pulse (which means the same bit pattern) is repeated once after t . If the fault is still present, the maximum test time is automatically reduced to 60 seconds and a diagnostic message is generated. If the fault is no longer present, the output channel is reintegrated after the next fault-free test cycle.

4.2.5.8 Diagnosis: Wire break

You can use a wire break test to monitor the connection from the output channel to the actuator.

Selecting this check box enables the wire break monitoring for the relevant channel.

Wire break is signaled when the following conditions are met:

- Wiring to the actuator is interrupted.
- A module that is disabled in fail-safe mode by the F-PM module has been removed.

You also have to activate the light test to detect a wire break with an output signal "0".

4.3 Address space

Address assignment of power module F-PM-E 24VDC/8A PPM ST

The F-PM-E 24VDC/8A PPM ST power module occupies the following address areas in the F-CPU:

Table 4- 2 Address assignment in the F-CPU

Occupied bytes in the F-CPU:	
In input range	In output range
x + 0 to x + 6	x + 0 to x + 4

x = Module start address

Address assignment of the user data and value status of power module F-PM-E 24VDC/8A PPM ST

Of the assigned addresses of power module F-PM E 24VDC/8A PPM ST, the user data occupy the following addresses in the F-CPU:

Table 4- 3 Address assignment of user data in the input range

Byte in the F-CPU	Assigned bits in F-CPU per F-module:							
	7	6	5	4	3	2	1	0
x + 0	—	—	—	—	—	—	DI ₁	DI ₀
x + 1	—	—	—	—	—	—	Value status for DI ₁	Value status for DI ₀
x + 2	—	—	—	—	—	—	—	Value status DQ ₀

x = Module start address

Table 4- 4 Address assignment of user data in the output range

Byte in the F-CPU	Assigned bits in F-CPU per F-module:							
	7	6	5	4	3	2	1	0
x + 0	—	—	—	—	—	—	—	DQ ₀

x = Module start address

Note

You may only access the addresses occupied by user data and value status.

The other address areas occupied by the F-modules are assigned for functions including safety-related communication between the F-modules and F-CPU in accordance with PROFIsafe.

1oo2 evaluation of the sensors combines the two channels. With 1oo2 evaluation of the sensors you may only access the low order channel in the safety program.

Additional information

For detailed information about F-I/O access, refer to the SIMATIC Safety – Configuring and Programming (<http://support.automation.siemens.com/WW/view/en/54110126>) manual.

See also

Value status (Page 75)

Applications of the F-I/O module

5.1 Applications for the output DQ/P1 and P2

Conditions for achieving SIL/Cat./PL

The table below lists the conditions which have to be met for achieving the various safety categories.

Table 5- 1 Conditions for achieving SIL/Cat./PL

F-PM-E 24VDC/8A PPM ST		Achievable safety class
Digital output DQ	Without standard DQ modules	SIL3/Cat.4/PLe
	With standard DQ modules	SIL2/Cat.3/PLd

5.1.1 Applications: Safety mode up to SIL3/Cat.4/PLe

Wiring

The wiring is carried out on the matching BaseUnit (Page 13).

5.1.1.1 Application: Wiring a load to the digital output, PM switching

The fail-safe digital output consists of two P-switches for DQ-P₀ and one M-switch for DQ-M₀. They connect the load between the P-switches DQ-P₀ and the M-switch DQ-M₀. The two P-switches and the M-switch are always activated so that voltage is applied to the load. This circuit achieves SIL3/Cat.4/PLe.

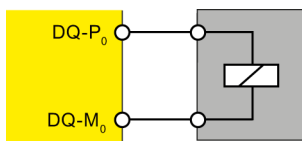

Figure 5-1 Wiring diagram of power module F-PM-E 24VDC/8A PPM ST

	WARNING
In order to achieve SIL3/Cat.4/PLe with this wiring, you must install a qualified actuator, for example, in accordance with IEC 60947.	

Parameter assignment

Assign the following parameter for the corresponding channel:

Table 5-2 Parameters

Parameter	
Output type	PM switching

5.1.1.2 Application: Wiring a load to the digital output, PP switching

The fail-safe digital output consists of two P-switches for DQ-P₀ and one M-switch for DQ-M₀. You connect the load between the P-switch DQ-P₀ and chassis in this case. The two P-switches are always activated so that voltage is applied to the load. This circuit achieves SIL3/Cat.4/PLe.

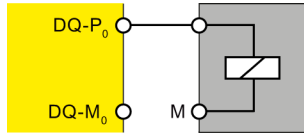

Figure 5-2 Wiring diagram of power module F-PM-E 24VDC/8A PPM ST

	WARNING
<p>In order to achieve SIL3/Cat.4/PLe with this wiring, you must install a qualified actuator, for example, in accordance with IEC 60947.</p>	

Parameter assignment

Assign the following parameter for the corresponding channel:

Table 5-3 Parameters

Parameter	
Output type	PP switching

5.1.1.3 Application: Wiring two loads in parallel to the digital output, PM switching

You achieve SIL3/Cat.4/PLe with the following wiring variant.

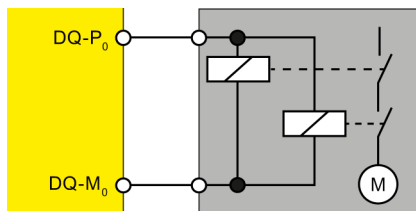

Figure 5-3 Wiring diagram for connecting two relays each in parallel to F-DQ of power module F-PM-E 24VDC/8A PPM ST

Note

When two relays are connected in parallel to one digital output (as shown above), a wire break is only detected if the wire break disconnects both relays from P or M. The diagnostics generated in the process is not safety-related.

Parameter assignment

Assign the following parameter for the corresponding channel:

Table 5-4 Parameters

Parameter	
Output type	PM switching

5.1.1.4 Application: Wiring two loads in parallel to the digital output, PP switching

You achieve SIL3/Cat.4/PLe with the following wiring variant.

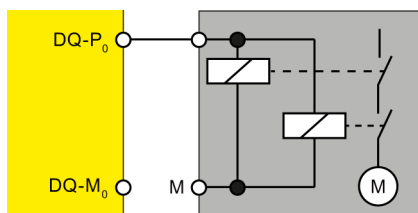

Figure 5-4 Wiring diagram for connecting two relays each in parallel to F-DQ of power module F-PM-E 24VDC/8A PPM ST

Note

When two relays are connected in parallel to one digital output (as shown above), a wire break is only detected if the wire break disconnects both relays from P or M. The diagnostics generated in the process is not safety-related.

Parameter assignment

Assign the following parameter for the corresponding channel:

Table 5-5 Parameters

Parameter	
Output type	PP switching

5.2 Applications for inputs

5.2.1 Applications of the electronic module

Selecting the application

The diagram below supports you in selecting the application that suits your fail-safe requirements. In the following sections, you will learn how to wire the F-module, the specific parameters you must assign in STEP 7 Safety and the errors that are detected.

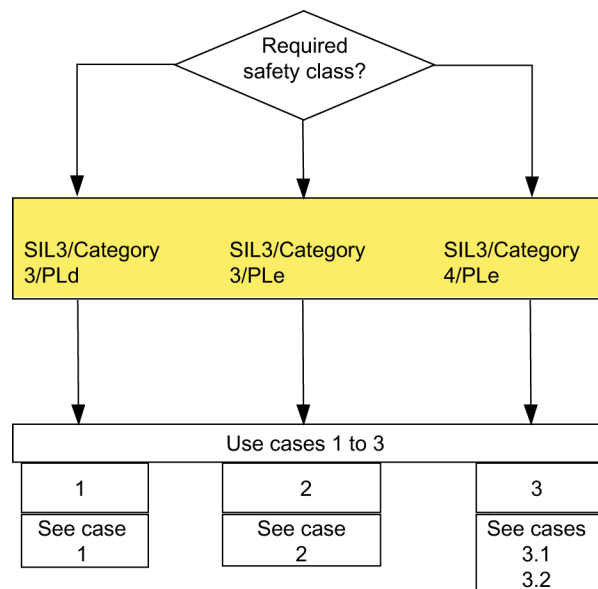

Figure 5-5 Selecting the application – digital inputs of the F-PM-E 24VDC/8A PPM ST

WARNING

The achievable safety class depends on the quality of the sensor and the duration of the proof-test interval in accordance with IEC 61508:2010. If the quality of the sensor is lower than the quality required by the safety class, redundant sensors connected via two channels must be used and evaluated.

Conditions for achieving SIL/Cat./PL

The table below lists the conditions which have to be met for achieving at least the corresponding safety requirements.

Table 5- 6 Conditions for achieving SIL/Cat./PL

Application	Sensor evaluation	Sensor supply	Achievable SIL/Cat./PL
1	1oo1	Any	3 / 3 / d
2	1oo2 equivalent	Internal, without short circuit test	3 / 3 / e
		External	
3.1	1oo2 equivalent	Internal, with short circuit test	3 / 4 / e
3.2	1oo2 non-equivalent	External/internal, with short circuit test	

Sensor requirements

Information on safety-related use of sensors is available in the section Requirements for sensors and actuators for fail-safe modules in the ET 200SP distributed I/O system (<http://support.automation.siemens.com/WW/view/en/58649293>) system manual.

5.2.2 Application 1: Safety mode SIL3/Cat.3/PLd

Wiring

The wiring is carried out on the matching BaseUnit (Page 13).

Sensor supply

The sensor supply can be powered internally or externally.

Wiring diagram – connecting one sensor via one channel

One sensor is connected via one channel (1oo1 evaluation) for each process signal. Any sensor supply of the module can be assigned to each input.

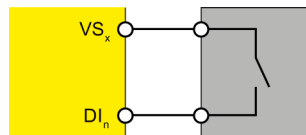

Figure 5-6 One sensor connected via one channel, internal sensor supply

You can also supply the sensor by means of an external sensor supply.

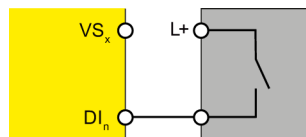

Figure 5-7 One sensor connected via one channel, external sensor supply

⚠ WARNING

To achieve SIL3/Cat.3/PLd using this wiring, you must use a qualified sensor.

Parameter assignment

Assign the following parameters for the corresponding channel:

Table 5- 7 Parameter assignment

Parameters	Channel with internal sensor supply	Channel with external sensor supply
Sensor evaluation	1oo1 evaluation	
Short circuit test	<ul style="list-style-type: none">• disable• enable	disable
Sensor supply	<ul style="list-style-type: none">• Sensor supply n	External sensor supply*

*) Otherwise a diagnostic message will be generated when short circuit test is activated.

Fault detection

The following table presents fault detection according to the sensor supply and the parameter assignment for the short circuit test:

Table 5- 8 Fault detection

Fault	Fault detection		
	Internal sensor supply and short circuit test activated	Internal sensor supply and short circuit test deactivated	External sensor supply
Short circuit with other channels or other sensor supplies (short circuit with other channels is detected only if they use a different sensor supply)	yes*	no	no
Short circuit with L+ to DI _n	yes	no	no
Short circuit with M to DI _n	yes*	yes*	no
Discrepancy error	—	—	—
Short circuit with L+ to VS _n	yes	no	—
Short circuit with M to VS _n or defective	yes	yes	—

*) Fault detection only if signals are corrupted. That is, the read signal differs from the sensor signal. If there is no signal corruption with respect to the sensor signal, fault detection is not possible and is not required from a safety standpoint.

WARNING

If the short circuit test is not activated or the sensor supply to digital inputs is set to "External sensor supply", the wiring between the sensor and the input channel must be short circuit proof.

5.2.3 Application 2: Safety mode SIL3/Cat.3/PLe

Assigning inputs to each other

The F-PM-E 24VDC/8A PPM ST power module has two fail-safe inputs, DI₀ and DI₁ (SIL3). You can combine the two inputs into one input.

The process signal is supplied by channel DI₀.

Wiring

The wiring is carried out on the matching BaseUnit (Page 13).

Sensor supply

The sensor supply can be powered internally or externally.

Wiring diagram – connecting a two-channel sensor via two channels

A two-channel sensor is connected equivalent to two inputs of the F-module for each process signal (1oo2 evaluation).

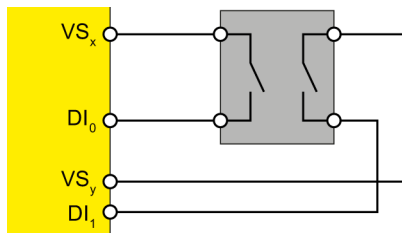

Figure 5-8 One two-channel sensor connected via two channels, internal sensor supply

You can also supply the sensor by means of an external sensor supply.

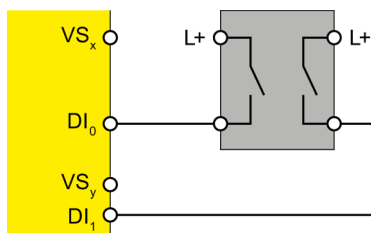

Figure 5-9 One two-channel sensor connected via two channels, external sensor supply

Wiring diagram – connecting two single-channel sensors via two channels

Two single-channel sensors that capture the same process value are connected to two inputs of the F-module for each process signal (1oo2 evaluation).

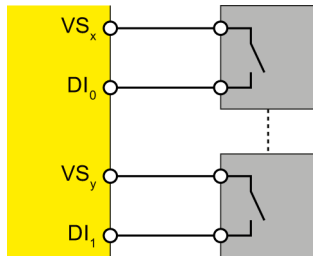

Figure 5-10 Two single-channel sensors connected via two channels, internal sensor supply

You can also supply the sensor by means of an external sensor supply.

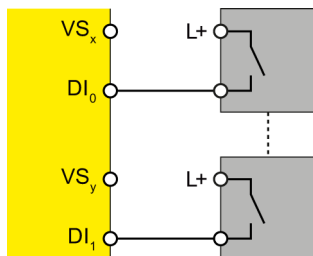

Figure 5-11 Two single-channel sensors connected via two channels, external sensor supply

	WARNING
To achieve SIL3/Cat.3/PLe using this wiring, you must use a qualified sensor.	

Parameter assignment

Assign the following parameters for the corresponding channel:

Table 5- 9 Parameter assignment

Parameter	Channel with internal sensor supply	Channel with external sensor supply
Sensor evaluation	1oo2 evaluation, equivalent	
Short circuit test	<ul style="list-style-type: none"> • disable • enable 	disable

Fault detection

The following table presents fault detection according to the sensor supply and the parameter assignment for the short circuit test:

Table 5- 10 Fault detection

Fault	Fault detection	
	Internal sensor supply and short circuit test deactivated	External sensor supply
Short circuit within the channel pair, with other channels or other sensor supplies	no	no
Short circuit with L+ to DI _n	yes*	yes*
Short circuit with M to DI _n	yes*	yes*
Discrepancy error	yes	yes
Short circuit with L+ to VS _n	no	no
Short circuit with M to VS _n or defective	yes	—

*) Fault detection only if signals are corrupted. That is, the read signal differs from the sensor signal (discrepancy error). If there is no signal corruption with respect to the sensor signal, fault detection is not possible and is not required from a safety standpoint.

5.2.4 Application 3: Safety mode SIL3/Cat.4/PLe

Assigning inputs to each other

The F-PM-E 24VDC/8A PPM ST power module has two fail-safe inputs, DI₀ and DI₁ (SIL3). You can combine the two inputs into one input.

The process signal is supplied by channel DI₀.

Wiring

The wiring is carried out on the matching BaseUnit (Page 13).

Sensor supply

The sensor must be supplied **internally** for application 3.1 (Page 52).

The sensor can be supplied internally or externally for application 3.2 (Page 54).

Requirements for applications in machine protection with Cat.4

Both conditions must be met for applications in machine protection with Cat.4:

- The wiring between sensors and automation system and between automation system and actuators must be designed to state-of-the-art engineering and standards to prevent short circuits.
- All short circuits listed in Table 5-12 Fault detection (Page 53) and Table 5-14 Fault detection (Page 56) must be detected. You only need to detect **one** short circuit because two faults are required to generate it. This means both signal cables in short circuit have an isolation fault. A multiple short circuit analysis is not required.

Procedures for locating all short circuits are also permitted if single short circuits are not located. One of the two conditions must be met for this purpose:

- Short circuits may not corrupt the read signals compared to the sensor signals.
- Short circuits cause a corruption of the read signals compared to sensor signals in the direction that ensures safety.

5.2.4.1 Application 3.1 (SIL3/Cat.4/PLe)

Wiring diagram – connecting a two-channel sensor via two channels

A two-channel sensor is connected to both inputs of the power module for each process signal (1oo2 evaluation).

Supply the sensors from two different sensor supplies.

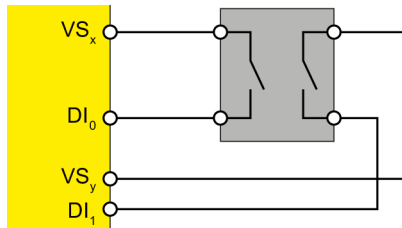

Figure 5-12 One two-channel sensor connected via two channels, internal sensor supply

You can also connect two single-channel sensors via two channels. In this case, the same process variable is acquired with two mechanically separate sensors.

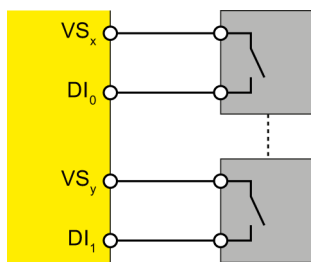

Figure 5-13 Two single-channel sensors connected via two channels, internal sensor supply

	WARNING
To achieve SIL3/Cat.4/PLe using this wiring, you must use a suitably qualified sensor.	

Parameter assignment

Assign the following parameters for the corresponding channel:

Table 5- 11 Parameter assignment

Parameter	Channel with internal sensor supply
Sensor evaluation	1oo2 evaluation, equivalent
Short circuit test	enable
Sensor supply	<ul style="list-style-type: none"> • Sensor supply n • External sensor supply

Fault detection

The following table presents fault detection according to the sensor supply and the parameter assignment for the short circuit test:

Table 5- 12 Fault detection

Fault	Fault detection
Short circuit within the channel pair, with other channels or other sensor supplies	yes*
Short circuit with L+ to DI _n	yes* / yes (for channel whose short circuit test is activated)
Short circuit with M to DI _n	yes*
Discrepancy error	yes
Short circuit with L+ to VS _n	yes
Short circuit with M to VS _n or defective	yes

*) Fault detection only if signals are corrupted. That is, the read signal differs from the sensor signal (discrepancy error). If there is no signal corruption with respect to the sensor signal, fault detection is not possible and is not required from a safety standpoint.

5.2.4.2 Application 3.2 (SIL3/Cat.4/PLe)

Wiring diagram – connecting a nonequivalent sensor nonequivalent via two channels

A nonequivalent sensor is connected nonequivalent via 2 channels to both inputs of the power module for each process signal (1oo2 evaluation, nonequivalent).

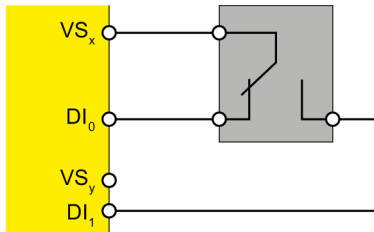

Figure 5-14 Nonequivalent sensor connected, internal sensor supply

You can also supply the sensor by means of an external sensor supply.

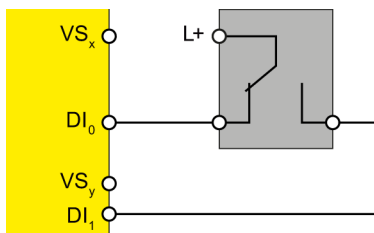



Figure 5-15 Nonequivalent sensor connected, external sensor supply

 WARNING
To achieve SIL3/Cat.4/PLe using this wiring, you must use a suitably qualified sensor.

Wiring diagram – connecting two single-channel sensors nonequivalent via two channels

Two single-channel sensors are connected nonequivalent to both inputs of the power module for each process signal (1oo2 evaluation).

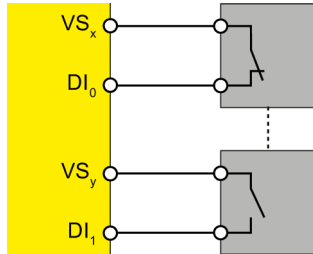

Figure 5-16 Two single-channel sensors connected nonequivalent, internal sensor supply

You can also supply the sensors by means of an external sensor supply.

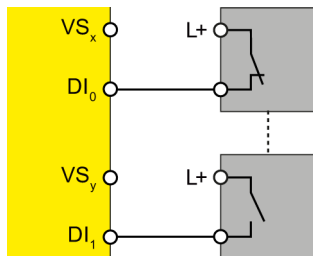

Figure 5-17 Two single-channel sensors connected nonequivalent, external sensor supply

	WARNING
To achieve SIL3/Cat.4/PLe using this wiring, you must use a suitably qualified sensor.	

Parameter assignment

Assign the following parameters for the corresponding channel:

Table 5- 13 Parameter assignment

Parameters	
Sensor evaluation	1oo2 evaluation, non equivalent
Short circuit test	<ul style="list-style-type: none"> • disable • enable
Sensor supply	<ul style="list-style-type: none"> • Sensor supply n • External sensor supply

Fault detection

The following table presents fault detection according to the sensor supply and the parameter assignment for the short circuit test:

Table 5- 14 Fault detection

Fault	Fault detection
Short circuit within the channel pair, with other channels or other sensor supplies	yes
Short circuit with L+ to DI _n	yes* / yes (for channel whose short circuit test is activated)
Short circuit with M to DI _n	yes*
Discrepancy error	yes
Short circuit with L+ to VS _n	yes, if used
Short circuit with M to VS _n or defective	yes, if sensor supply is activated

*) Fault detection only if signals are corrupted. That is, the read signal differs from the sensor signal (discrepancy error). If there is no signal corruption with respect to the sensor signal, fault detection is not possible and is not required from a safety standpoint.

5.3 Application for internal evaluation

Function

The evaluation of the safety function takes place internally in the F-module.

You can choose between 1oo1 evaluation or nonequivalent/equivalent 1oo2 evaluation of the sensors.

- With 1oo1 evaluation, the activated inputs are logically ANDed with the process image of output DQ₀.
- With 1oo2 evaluation, the result of the inputs is logically ANDed with the process image of output DQ₀.

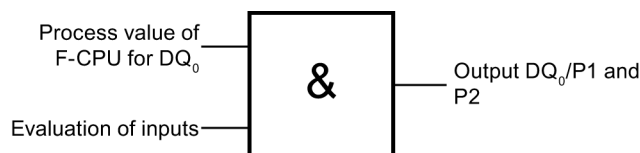

The acknowledgment in case of an error takes place by the safety program in the F-CPU.

Use the wiring diagrams Applications for the output DQ/P1 and P2 (Page 39) and Applications for inputs (Page 43).

You achieve SIL3/Cat.4/PLe.

WARNING

In order to achieve SIL3/Cat.4/PLe with this wiring, you must install a qualified actuator and sensor, for example, in accordance with IEC 60947.

Note

If an error occurs at the inputs in this application, the F-module also outputs the error message "Safety-related shutdown" or "Safety event" for the output. Following elimination of the error at the inputs, a reintegration of the output is only possible after the bit pattern test (within the test time shortened to 60 s) has been performed.

Interconnection example

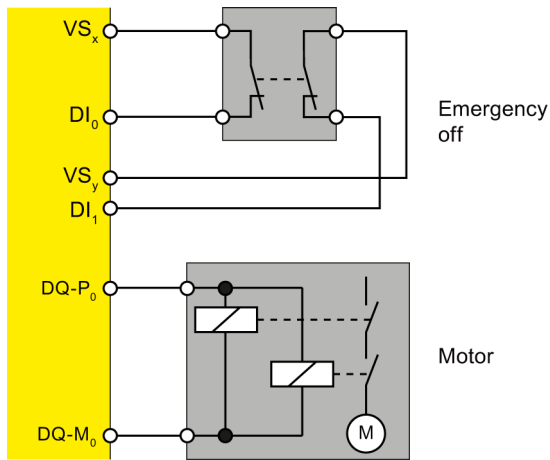

Figure 5-18 Emergency Off shutdown of a motor with equivalent 1oo2 evaluation

Parameter assignment

Assign the following parameters for the F-module:

Parameter	
Control of the output	F-CPU and onboard F-DI
Type of sensor interconnection	<ul style="list-style-type: none"> • 1-channel • 2-channel equivalent • 2-channel, non equivalent
Sensor supply	Sensor supply 0, Sensor supply 1, or External sensor supply

5.4 Applications for safety-related shutdown of standard modules

5.4.1 Safety-related shutdown of standard output modules, PM-switching

The F-PM-E 24VDC/8A PPM ST power module opens, together with the matching BaseUnit, a new potential group. Standard DQ modules that you use in the potential group can undergo a safety-related shutdown by the F-PM-E 24VDC/8A PPM ST power module. For this, the F-PM-E 24VDC/8A PPM ST power module performs a safety-related shutdown of voltage buses P1 and P2.

Configure the power module parameters as described in section Terminal assignment (Page 13).

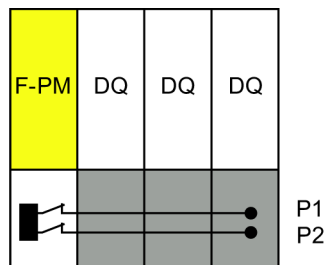

Figure 5-19 Safety-related shutdown of standard output modules

You achieve SIL2/Cat.3/PLd with safety-related shutdown of standard DQ modules.

 **WARNING**

Safety-related activation of standard DQ module outputs is not possible; only safety-related **shutdown** is possible. You must therefore take the following possible effects into consideration:

In the worst case scenario, you must consider all possible faults of the standard DQ modules and the program controlling them for which there is no direct fault detection. For example, the F-PM-E 24VDC/8A PPM ST and F-DQ 4×24VDC/2A PM HF do not detect external short circuits to L+ at the standard DQ module outputs. All faults of the standard DQ modules act on the process via final controlling elements. The process must be made known to the F-CPU by way of sensors and a corresponding safety program.

Because safety-critical faults in the standard DQ modules cannot be detected by self-tests within the module, the "diagnostics" must be performed indirectly via the controlled process. As long as the incorrectly controlled process does not pose a hazard, the safety-related control does not intervene. It only performs a shutdown if the process exhibits unwanted or potentially dangerous behavior.

It therefore follows that the reaction times for faults within standard DQ modules are not based on the specified short fault detection times of S7 but rather depend on the controlled process and the evaluation of feedback from the process.

Safety-related process values must be

- safely
- read in by way of fail-safe inputs or fail-safe input modules (e.g., F-DI)
- the safety function must be evaluated locally in the power module F-PM-E 24VDC/8A PPM ST or processed by the fail-safe CPU to form output commands and
- output by the fail-safe output module for shutdown of the corresponding safety relay or
- output by the F-PM-E 24VDC/8A PPM ST fail-safe power module.

If the expectations at the process end are not met (due to a process malfunction or faulty standard DO modules), the standard DQ modules must be brought to a safe state by way of the higher-level safety circuit.

The process safety time is of particular importance here. During this process safety time, no hazard is posed by an incorrectly controlled process.

The safety program must react in a safety-related and logical manner to unwanted or potentially dangerous states in the process via the F-PM-E 24VDC/8A PPM ST, F-DQ 4×24VDC/2A PM HF and fail-safe output modules.

If you want to avoid the problems described above completely, we recommend that you use the PM-switching F-DQ 4×24VDC/2A PM HF module instead of standard DQ modules.

 **WARNING**

Always connect the 24 V DC supply for the standard ET 200SP modules to the F-PM-E 24VDC/8A PPM ST. Otherwise, the outputs of DQ modules may exhibit safety-critical behavior.

⚠ WARNING
<p>When supplying standard DQ modules, always use the BaseUnits of these modules to supply the actuators (actuator feedback on the DQ module).</p> <p>See also Terminal assignment (Page 13).</p>

⚠ WARNING
<p>Note the following for the "Safety-related shutdown of standard modules" application:</p> <p>If standard modules behind a F-PM-E 24VDC/8A PPM ST power module are exposed to surge conditions, immunity according to failure criterion B is achieved (according to EN 298 and IEC 61326-3-2), i.e., the standard modules may fail in the event of surge conditions.</p>

5.4.2 Safety-related shutdown of standard output modules, PP-switching

The F-PM-E 24VDC/8A PPM ST power module opens, together with the matching BaseUnit, a new potential group . Standard DQ modules that you use in the potential group can undergo a safety-related shutdown by the F-PM-E 24VDC/8A PPM ST power module. For this, the F-PM-E 24VDC/8A PPM ST power module performs a safety-related shutdown of voltage bus P1.

Configure the power module parameters as described in section Terminal assignment (Page 13).

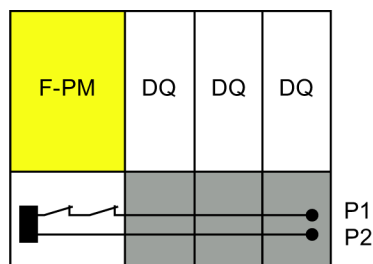

Figure 5-20 Safety-related shutdown of standard output modules

You achieve SIL2/Cat.3/PLd with safety-related shutdown of standard DQ modules.

 **WARNING**

Safety-related activation of standard DQ module outputs is not possible; only safety-related **shutdown** is possible. You must therefore take the following possible effects into consideration:

In the worst case scenario, you must consider all possible faults of the standard DQ modules and the program controlling them for which there is no direct fault detection. For example, the F-PM-E 24VDC/8A PPM ST and F-DQ 4×24VDC/2A PM HF do not detect external short circuits to L+ at the standard DQ module outputs. All faults of the standard DQ modules act on the process via final controlling elements. The process must be made known to the F-CPU by way of sensors and a corresponding safety program.

Because safety-critical faults in the standard DQ modules cannot be detected by self-tests within the module, the "diagnostics" must be performed indirectly via the controlled process. As long as the incorrectly controlled process does not pose a hazard, the safety-related control does not intervene. It only performs a shutdown if the process exhibits unwanted or potentially dangerous behavior.

It therefore follows that the reaction times for faults within standard DQ modules are not based on the specified short fault detection times of S7 but rather depend on the controlled process and the evaluation of feedback from the process.

Safety-related process values must be

- safely
- read in by way of fail-safe inputs or fail-safe input modules (e.g., F-DI)
- the safety function must be evaluated locally in the power module F-PM-E 24VDC/8A PPM ST or processed by the fail-safe CPU to form output commands and
- output by the fail-safe output module for shutdown of the corresponding safety relay or
- output by the F-PM-E 24VDC/8A PPM ST fail-safe power module.

If the expectations at the process end are not met (due to a process malfunction or faulty standard DO modules), the standard DQ modules must be brought to a safe state by way of the higher-level safety circuit.

The process safety time is of particular importance here. During this process safety time, no hazard is posed by an incorrectly controlled process.

The safety program must react in a safety-related and logical manner to unwanted or potentially dangerous states in the process via the F-PM-E 24VDC/8A PPM ST, F-DQ 4×24VDC/2A PM HF and fail-safe output modules.

If you want to avoid the problems described above completely, we recommend that you use the PM-switching F-DQ 4×24VDC/2A PM HF module instead of standard DQ modules.

 **WARNING**

Always connect the 24 V DC supply for the standard ET 200SP modules to the F-PM-E 24VDC/8A PPM ST. Otherwise, the outputs of DQ modules may exhibit safety-critical behavior.

 **WARNING**

When supplying standard DQ modules, always use the BaseUnits of these modules to supply the actuators (actuator feedback on the DQ module).

See also Terminal assignment (Page 13).

 **WARNING**

Note the following for the "Safety-related shutdown of standard modules" application:

If standard modules behind a F-PM-E 24VDC/8A PPM ST power module are exposed to surge conditions, immunity according to failure criterion B is achieved (according to EN 298 and IEC 61326-3-2), i.e., the standard modules may fail in the event of surge conditions.

Interrupts/diagnostic messages

6.1 Status and error display

LED display

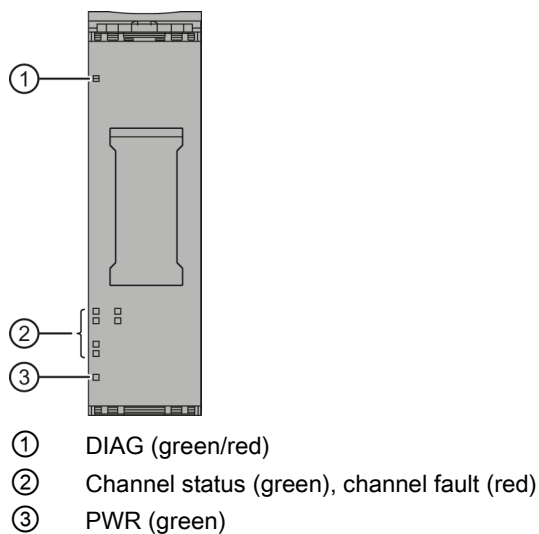



Figure 6-1 LED display

Meaning of the LED displays



The following tables explain the meaning of the status and error displays. Remedies for diagnostic messages can be found in section Diagnostic messages (Page 69).

 WARNING
The DIAG LED and the channel status and channel fault LEDs of the inputs and outputs are not designed as safety-related LEDs and therefore may not be evaluated for safety-related activities.

6.1 Status and error display





PWR LED

Table 6- 1 Meaning of the PWR LED

PWR	Meaning
 Off	Supply voltage L+ missing
 On	Supply voltage L+ available







DIAG LED

Table 6- 2 Meaning of the DIAG LED

DIAG	Meaning
 Off	Backplane bus supply of the ET 200SP not okay
 Flashing	Module parameters not configured
 On	Module parameters configured and no module diagnostics
 Flashing	Module parameters configured and module diagnostics

Channel status/channel fault LED

Table 6- 3 Meaning of the channel status/channel fault LED

Channel status	Channel fault	Meaning
 Off	 Off	Process signal = 0 and no channel diagnostics
 On	 Off	Process signal = 1 and no channel diagnostics
 Off	 On	Process signal = 0 and channel diagnostics
 Alternately flashing		Channel waiting for user acknowledgment

Channel status/DIAG/channel fault LED

Table 6- 4 Meaning of the channel status/DIAG/channel fault LED

Channel status	DIAG	Channel fault	Meaning
□ Off	⚡ Flashing	■ All On	The PROFIsafe address does not match the configured PROFIsafe address
⚡ Flashing	⚡ Flashing	□ Off	Identification of the F-module when assigning the PROFIsafe address

6.2 Interrupts

Introduction

The F-PM-E 24VDC/8A PPM ST fail-safe power module supports diagnostic interrupts.

Diagnostic interrupt

The F-module generates a diagnostic interrupt for each diagnostic message described in section Diagnostic messages (Page 69).

The table below provides an overview of the diagnostic interrupts of the F-module . The diagnostic interrupts are assigned either to one channel or the entire F-module.

 WARNING
Before acknowledging the short circuit diagnostic message, remedy the respective fault and validate your safety function. Follow the fault remedying procedure described in section Diagnostic messages (Page 69).

Table 6- 5 Diagnostic interrupts of the F-PM-E 24VDC/8A PPM ST

Diagnostic interrupt	Fault code	Signaled in application	Scope of diagnostic interrupt	Configurable
Overtemperature	5 _D	—	F-module	No
Parameter assignment error	16 _D			
Load voltage missing	17 _D			
Access to retentive storage of F-address not possible	30 _D			
Different destination address (F_Dest_Add)	64 _D			

6.2 Interrupts

Diagnostic interrupt	Fault code	Signaled in application	Scope of diagnostic interrupt	Configurable		
Invalid destination address (F_Dest_Add)	65 _D					
Invalid source address (F_Source_Add)	66 _D					
Watchdog time is 0 ms (F_WD_Time or F_WD_Time2)	67 _D					
"F_SIL" parameter exceeds the application-specific SIL	68 _D					
"F_CRC_Length" parameter does not match the generated CRC	69 _D					
Incorrect F-parameter version or F_Block_ID	70 _D					
CRC1 error	71 _D					
Inconsistent iParameters (iParCRC error)	75 _D					
F_Block_ID not supported	76 _D					
Internal error	256 _D					
Time monitoring activated	259 _D					
Internal supply voltage of the module failed	260 _D					
Output short-circuited to L+	261 _D				Channel	Yes
Output short-circuited to ground	262 _D					
Wire break	265 _D					
Incorrect/inconsistent firmware present. Firmware update required	283 _D	2, 3		No		
Discrepancy error, channel status 0/0	768 _D					
Discrepancy error, channel status 0/1	769 _D					
Discrepancy error, channel status 1/0	770 _D					
Discrepancy error, channel status 1/1	771 _D	1, 2, 3		Yes		
Input signal could not be clearly detected	773 _D					
Short circuit of internal sensor supply to L+	774 _D					
Overload or short circuit of internal sensor supply to ground	775 _D	1				
No pulse detected	778 _D					
Sensor signal chatters	784 _D	1,2,3	F-module	No		
Switching frequency too high	785 _D					
Undertemperature	786 _D					
Fault in input circuit	787 _D					
PROFIsafe communication error (timeout)	792 _D					
PROFIsafe communication error (CRC)	793 _D					
PROFIsafe address assignment error	794 _D					
Input short-circuited to L+	796 _D	Channel	Yes			
Output defective	797 _D					
Readback error	798 _D	—		No		
Overload	800 _D					
Supply voltage too high	802 _D					
Supply voltage too low	803 _D	1, 2, 3	F-module			

6.3 Diagnostic messages

Digital module error types

Module faults are indicated as diagnostics (module status).

Once the fault is eliminated, the F-module must be reintegrated in the safety program. For additional information on passivation and reintegration of F-I/O, refer to the SIMATIC Safety – Configuring and Programming

(<http://support.automation.siemens.com/WW/view/en/54110126>) manual.

Table 6- 6 Diagnostic messages of the F-PM-E 24VDC/8A PPM ST

Diagnostic message	Fault code	Meaning	Remedy
Overtemperature	5D	An excessively high temperature was measured in the F-module.	Operate the F-module within the specified temperature range. (see Technical specifications (Page 77)) Once the fault has been eliminated, the F-module must be removed and inserted or the power switched OFF and ON
Wire break	6D	Possible causes: <ul style="list-style-type: none"> • There is an interrupted cable between the module and actuator. • The channel is not connected (open). • There is a short circuit between channels with different signals. 	<ul style="list-style-type: none"> • Establish a cable connection. • Disable the wire break detection for the channel in the parameter assignment. • Eliminate the short circuit.
Parameter assignment error	16D	Parameter assignment errors include: <ul style="list-style-type: none"> • The F-module cannot use the parameters (unknown, invalid combination, etc.). • The F-module parameters have not been configured. 	Correct the parameter assignment.
Load voltage missing	17D	Missing or insufficient supply voltage L+	<ul style="list-style-type: none"> • Check supply voltage L+ at BaseUnit • Check BaseUnit type
Access to retentive storage of F-address not possible	30D	The F-destination address stored in the coding element cannot be accessed.	Verify that the coding element is present or replace the coding element.
Different destination address (F_Dest_Add)	64D	The PROFIsafe driver has detected a different F-destination address.	Check the parameter assignment of the PROFIsafe driver and the address setting of the F-module.
Invalid destination address (F_Dest_Add)	65D	The PROFIsafe driver has detected an invalid F-destination address.	Check the parameter assignment of the PROFIsafe driver.
Invalid source address (F_Source_Add)	66D	The PROFIsafe driver has detected an invalid F-source address.	

6.3 Diagnostic messages

Diagnostic message	Fault code	Meaning	Remedy
Watchdog time is 0 ms (F_WD_Time or F_WD_Time2)	67 _D	The PROFIsafe driver has detected an invalid watchdog time.	
"F_SIL" parameter exceeds the application-specific SIL	68 _D	The PROFIsafe driver has detected a discrepancy between the SIL setting of the communication and the application.	
"F_CRC_Length" parameter does not match the generated CRC	69 _D	The PROFIsafe driver has detected a discrepancy in the CRC length.	
Incorrect F-parameter version or F_Block_ID	70 _D	The PROFIsafe driver has detected an incorrect version of the F-parameters or an invalid F_Block_ID.	
CRC1 error	71 _D	The PROFIsafe driver has detected inconsistent F-parameters.	
Inconsistent iParameters (iParCRC error)	75 _D	The PROFIsafe driver has detected inconsistent iParameters.	Check the parameter assignment.
F_Block_ID not supported	76 _D	The PROFIsafe driver has detected an incorrect Block ID.	Check the parameter assignment of the PROFIsafe driver.
Internal error	256 _D	Possible causes: <ul style="list-style-type: none"> Impermissibly high electromagnetic interference is present. The F-module is defective. 	<ul style="list-style-type: none"> Eliminate the interference. The module must then be pulled and plugged, or the power switched OFF and ON Replace the F-module.
Internal supply voltage of the module failed	260 _D	Possible causes: <ul style="list-style-type: none"> Impermissibly high electromagnetic interference is present. The F-module is defective. 	<ul style="list-style-type: none"> Eliminate the electromagnetic interference. The module must then be pulled and plugged, or the power switched OFF and ON Replace the F-module.
Output short-circuited to L+	261 _D	Short circuit to L+ can mean: <ul style="list-style-type: none"> The sensor cable is short-circuited to L+. The output cable is short-circuited to L+. 	Correct the process wiring.
Output short-circuited to ground	262 _D	Short circuit to ground can mean: <ul style="list-style-type: none"> The sensor cable is short-circuited to ground. The output cable is short-circuited to ground. The output signal is short-circuited to ground. 	Correct the process wiring.
Incorrect/inconsistent firmware present. Firmware update required	283 _D	The firmware is incomplete and/or firmware added to the F-module is incompatible. This leads to errors or functional limitations when operating the F-module.	<ul style="list-style-type: none"> Perform a firmware update for all parts of the F-module and note any error messages. Use only firmware versions released for this F-module.

Diagnostic message	Fault code	Meaning	Remedy
Discrepancy error, channel status 0/0	768 _D	Possible causes: <ul style="list-style-type: none"> • The process signal is faulty. • The sensor is defective. • The configured discrepancy time is too low. • There is a short circuit between an unconnected sensor cable and the sensor supply cable. • Wire break in connected sensor cable or the sensor supply cable • An error occurred during the discrepancy check. 	<ul style="list-style-type: none"> • Check the process signal. • Replace the sensor. • Check the parameter assignment of the discrepancy time. • Check the process wiring.
Discrepancy error, channel status 0/1	769 _D		
Discrepancy error, channel status 1/0	770 _D		
Discrepancy error, channel status 1/1	771 _D		
Input signal could not be clearly detected	773 _D	An error occurred in the plausibility check of the input signal between the processors. You must eliminate the error within 100 hours. If you do not eliminate the error within 100 hours, the F-module will become inoperative. Possible causes: <ul style="list-style-type: none"> • The input signal is faulty, e.g., as a result of impermissibly high electromagnetic interference. • A high-frequency input signal is present, e.g., due to mutual interference of sensors or the signal being above the sampling frequency of the input signal. • A momentary interruption/short circuit of the sensor cable (loose contact) is present. • The sensor/switch is bouncing. 	<ul style="list-style-type: none"> • Use shielded cables to reduce the EMC effects. • Reduce the input frequency. • Check the wiring of the sensor.
Short circuit of internal sensor supply to L+	774 _D	Possible causes: <ul style="list-style-type: none"> • There is a short circuit of the internal sensor supply with L+. • There is a short circuit of two sensor supplies. • The capacitance of the connected sensor for the configured test time is too high. • The sensor is defective. 	<ul style="list-style-type: none"> • Eliminate the short circuit in the process wiring. • Check the configured test time and the process wiring. • Replace the sensor.

6.3 Diagnostic messages

Diagnostic message	Fault code	Meaning	Remedy
Overload or short circuit of internal sensor supply to ground	775 _D	<p>Possible causes:</p> <ul style="list-style-type: none"> The internal sensor supply is short-circuited to ground. Impermissibly high electromagnetic interference is present. 	<ul style="list-style-type: none"> Eliminate the overload. Eliminate the short circuit in the process wiring. Check the "Sensor supply" parameter. Eliminate/reduce the electromagnetic interference.
No pulse detected	778 _D	<p>A pulse with a length greater than or equal to "Minimum pulse time" has not occurred within the time configured with the "Pulse monitoring window" parameter.</p> <p>Possible causes:</p> <ul style="list-style-type: none"> The "Pulse monitoring window" parameter setting is too low. The "Minimum pulse time" parameter setting is too high. There is a wire break in the process wiring. 	<ul style="list-style-type: none"> Check the "Pulse monitoring window" parameter. Check the "Minimum pulse time" parameter. Check the process wiring.
Sensor signal chatters	784 _D	<p>Too many signal changes have occurred within the time configured with the "Monitoring window" parameter.</p> <ul style="list-style-type: none"> The "Monitoring window" parameter setting is too high. The "Number of signal changes" parameter setting is too low. A momentary interruption/short circuit of the sensor cable (loose contact) is present. Impermissibly high electromagnetic interference is present. The sensor is bouncing. The sensor is defective. 	<ul style="list-style-type: none"> Check the "Monitoring window" parameter. Check the "Number of signal changes" parameter. Check the process wiring. Eliminate/reduce the electromagnetic interference. Replace the sensor.
Switching frequency too high	785 _D	The maximum switching frequency of the F-module has been exceeded.	Reduce the switching frequency. (see Technical specifications (Page 77))
Undertemperature	786 _D	The minimum permissible temperature limit has been violated.	Operate the F-module within the specified temperature range. (see Technical specifications (Page 77))
Fault in input circuit	787 _D	<p>The F-module has detected an internal error.</p> <p>Possible causes:</p> <ul style="list-style-type: none"> Impermissibly high electromagnetic interference is present. The F-module is defective. 	<ul style="list-style-type: none"> Eliminate/reduce the electromagnetic interference. Replace the F-module.

Diagnostic message	Fault code	Meaning	Remedy
PROFIsafe communication error (timeout)	792 _D	The PROFIsafe driver has detected a timeout. Possible causes: <ul style="list-style-type: none"> The F-monitoring time is set incorrectly. Bus faults are present. 	<ul style="list-style-type: none"> Check the parameter assignment. Ensure that communication is functioning correctly.
PROFIsafe communication error (CRC)	793 _D	The PROFIsafe driver has detected a CRC error. Possible causes: <ul style="list-style-type: none"> The communication between the F-CPU and F-module is disturbed. Impermissibly high electromagnetic interference is present. An error occurred in the sign-of-life monitoring. 	<ul style="list-style-type: none"> Check the communication connection between the F-module and F-CPU. Eliminate the electromagnetic interference.
PROFIsafe address assignment error	794 _D	An error occurred during the automatic PROFIsafe address assignment.	Check the configuration.
Input short-circuited to L+	796 _D	The input signal is short-circuited to L+.	Eliminate the short circuit.
Output defective	797 _D	The F-module has detected an internal error. Possible causes: <ul style="list-style-type: none"> Short circuit to L+ or M The F-module is defective. 	<ul style="list-style-type: none"> Check the wiring. Replace the F-module.
Readback error	798 _D	The F-module has detected an internal error. Possible causes: <ul style="list-style-type: none"> Impermissibly high electromagnetic interference is present. The F-module is defective. 	If the error persists, replace the F-module.
Overload	800 _D	The maximum permissible output current has been exceeded. The output stage has been switched off. Possible causes: <ul style="list-style-type: none"> A short circuit exists. 	Check the process wiring.
Supply voltage too high	802 _D	The supply voltage is too high.	Check the supply voltage.
Supply voltage too low	803 _D	The supply voltage is too low.	Check the supply voltage.

6.3 Diagnostic messages

Supply voltage outside the nominal range

In the case of a voltage dip in the supply voltage L+, the DIAG LED flashes and the module is passivated.

When the voltage has recovered (level must remain above the specified value for at least 1 minute (see Technical specifications (Page 77): Voltages, Currents, Potentials)), the DIAG LED stops flashing. The module remains passivated.

Behavior in case of cross circuit/short circuit to the sensor supply

When internal sensor supply is specified and short circuit test is disabled, short circuits to ground at the sensor supplies are detected. Channels for which the relevant sensor supply is configured will be passivated.

When internal sensor supply is specified and short circuit test is enabled, short circuits to ground and potential at the sensor supply are detected. Channels for which the relevant sensor supply is configured will be passivated.

Special features for fault detection

The detection of certain faults (short-circuits or discrepancy errors, for example) depends on the application, the wiring, and the parameter assignment of the short circuit test and the sensor power supply. The corresponding tables for fault detection for the applications are available under Applications of the F-I/O module (Page 39).

Generally applicable information on diagnostics

Information on diagnostics that pertains to all fail-safe modules (for example, readout of diagnostics functions or passivation of channels) is available in the SIMATIC Safety – Configuring and Programming (<http://support.automation.siemens.com/WW/view/en/54110126>) manual.

6.4 Value status

Properties

In addition to the diagnostic messages and the status and error display, the F-module makes available information about the validity of each input and output signal – the value status. The value status is entered in the process image along with the input signal.

Value status for digital input and output modules

The value status is additional binary information of a digital input or output signal. It is entered in the process image of the inputs (PII) at the same time as the process signal. It provides information about the validity of the input or output signal.

The value status is influenced by the wire break check, short-circuit, chatter monitoring, pulse extension, and plausibility check.

- 1_B: A valid process value is output for the channel.
- 0_B: A fail-safe value is output for the channel, or the channel is deactivated.

Assignment of the inputs and value status in the PII

Each channel of the F-module is assigned a value status in the process image of the inputs. You can find the assignment in section Address space (Page 36).

Reference

A detailed description of the evaluation and processing of the respective input signals can be found in the SIMATIC Safety – Configuring and Programming (<http://support.automation.siemens.com/WW/view/en/54110126>) manual.

Technical specifications

Technical specifications of F-PM-E 24VDC/8A PPM ST

	6ES7136-6PA00-0BC0
Product type designation	F-PM-E PPM 24VDC
General information	
Hardware product version	01
Firmware version	V1.0.0
Product function	
I&M data	Yes; IM0 to IM3
Engineering with	
STEP 7 TIA Portal configurable/integrated as of version	V12.0
STEP 7 configurable/integrated as of version	as of V5.5 SP3 / -
PROFIBUS as of GSD version/GSD revision	V2.3
PROFINET as of GSD version/GSD revision	V2.31
Operating mode	
Multi-output	No
Installation type/mounting	
Rack mounting possible	No
Front installation possible	No
Rail mounting possible	Yes; standard DIN rail
Wall mounting/direct mounting possible	No
Supply voltage	
Type of supply voltage	24 V DC
Rated value (DC)	24 V
Low limit of permissible range (DC)	20.4 V
High limit of permissible range (DC)	28.8 V
Reverse polarity protection	Yes
Input current	
Current consumption (rated value)	75 mA; without load
Current consumption, max.	21 mA; from backplane bus
Output voltage	
Rated value (DC)	24 V

6ES7136-6PA00-0BC0	
Sensor supply	
Number of outputs	2
Output current	
Up to 60 °C, max.	0.3 A
Short circuit protection	Yes; electronic (response threshold 0.7 A to 2.1 A)
24 V sensor supply	
24 V	Yes; min. L+ (-1.5 V)
Short circuit protection	Yes
Output current, max.	600 mA; total current of all sensors
Power	
Power consumption from the backplane bus	70 mW
Power loss	
Power loss, typ.	5 W
Address space	
Address space per module	
Input	7 bytes
Output	5 bytes
Digital inputs	
Number of inputs	2
m/p-reading	Yes; p-reading
Input characteristic curve according to IEC 61131, Type 1	Yes
Input voltage	
Type of input voltage	DC
Rated value, DC	24 V
For "0" signal	-30 to +5 V
For "1" signal	+15 to +30 V
Input current	
For "1" signal, typ.	3.7 mA
Input delay (for rated value of input voltage)	
For standard inputs	
<ul style="list-style-type: none"> • Assignable • For "0" to "1", min. • For "0" to "1", max. • For "1" to "0", min. • For "1" to "0", max. 	Yes 0.4 ms 20 ms 0.4 ms 20 ms
For counter/technological functions	
<ul style="list-style-type: none"> • Assignable 	No
Length of cable	
Cable length, shielded, max.	1000 m
Cable length unshielded, max.	500 m

	6ES7136-6PA00-0BC0
Digital outputs	
Number of outputs	1
Digital outputs, configurable	Yes
Short circuit protection	Yes
• Response threshold, typ.	> 14.8 A
Wire break detection	Yes
• Response threshold, typ.	8 mA
Overload protection	Yes
• Response threshold, typ.	8.8 A
Voltage induced on current interruption limited to	max 1.5 V
Switching capacity of outputs	
With resistive load, max.	8 A
With lamp load, max.	100 W
Load resistance range	
Low limit	3 Ω
High limit	2000 Ω
Output voltage	
Type of output voltage	DC
For "1" signal, min.	24 V; L+ (-0.5 V)
Output current	
For "1" signal, rated value	8 A
For "0" signal, residual current, max.	1.5 mA; PP-switching: Max. 1.5 mA; PM-switching: Max. 1 mA
Switching frequency	
With resistive load, max.	10 Hz; symmetrical
With inductive load, max.	0.1 Hz; acc. to IEC 947-5-1, DC13, symmetrical
With lamp load, max.	4 Hz; symmetrical
Total current of outputs	
Max. current per channel	8 A; (note derating data in the manual)
Max. current per module	8 A; (note derating data in the manual)
Length of cable	
Cable length, shielded, max.	1000 m
Cable length unshielded, max.	500 m
Interrupts/diagnostics/status information	
Fail-safe values can be switched to	No
Interrupts	
Diagnostic interrupt	Yes
Hardware interrupt	No
Diagnostic messages	
Diagnostics	Yes, see section "Interrupts/diagnostic messages" in the manual

6ES7136-6PA00-0BC0	
Diagnostics display LED	
RUN LED	Yes; green LED
ERROR LED	Yes; red LED
Monitoring of supply voltage	Yes; green PWR LED
Channel status display	Yes; green LED
For channel diagnostics	Yes; red LED
For module diagnostics	Yes; green/red DIAG LED
Electrical isolation	
Electrical isolation channels	
Between channels	No
Between the channels and the backplane bus	Yes
Between the channels and the supply voltage of the electronics	No
Permitted potential difference	
Between different circuits	60 V DC / 75 V AC
Isolation	
Isolation test voltage	707 V DC (type test)
Standards, approvals, certificates	
SIL acc. to IEC 61508	SIL 3
Suitable for safety functions	Yes
Maximum achievable safety class in safety mode	
Performance level according to EN ISO 13849-1	PLe
Low demand (PFD) acc. to SIL3	< 2.00E-05 1/h
High demand (PFH) acc. to SIL3	< 1.00E-09 1/h
Environmental conditions	
Operating temperature	
Min.	0 °C
Max.	60 °C
Horizontal installation, min.	0 °C
Horizontal installation, max.	60 °C
Vertical installation, min.	0 °C
Vertical installation, max.	50 °C
Storage/transport temperature	
Min.	-40 °C
Max.	70 °C
Dimensions	
Width	20 mm
Height	72 mm
Depth	55 mm
Weights	
Weight, approx.	70 g

Temperature characteristic values (derating)

Mounting position	Maximum temperature	Maximum output current
Horizontal	40 °C	8 A
	50 °C	6 A
	60 °C	4 A
Vertical	50 °C	4 A

Dimension drawing

See ET 200SP BaseUnits

(<http://support.automation.siemens.com/WW/view/en/58532597/133300>) manual

Response times

A.1 Response times

Introduction

The next section shows the response times of power module F-PM-E 24VDC/8A PPM ST. The response times of the fail-safe modules are included in the calculation of the F-system response time.

Times required for the calculation

Maximum internal processing time: $T_{max.} = 29 \text{ ms}$

Maximum cycle time: $T_{cycle} = 14 \text{ ms}$

Short circuit test time for the sensor supply configured for the channel = "Time for short circuit test" + "Startup time after short circuit test"

The input delay, short circuit test times, dark test time, switch-on time, discrepancy time, and test time are configured in STEP 7.

Definition of response time for fail-safe digital inputs

The response time represents the interval between a signal change at the digital input and reliable availability of the safety frame on the backplane bus.

Definition of response time for internal evaluation: Cycle time + Input delay + Short circuit test time + Maximum(readback time, switch-on time, light test time)

Maximum response time in the error-free case with 1oo1 evaluation

Maximum response time = T_{max} + Input delay + Short circuit test time for the sensor supply configured for the channel

Maximum response time in the error-free case with 1oo2 evaluation

Maximum response time = T_{max} + Input delay + Maximum (short circuit test time for the sensor supply configured for channel 0, short circuit test time for the sensor supply configured for channel n1)

Maximum response time with external short circuits

Maximum response time = Input delay + $(n \times T_{cycle})$ + Sum(all short circuit test times + all startup times of sensors with activated short circuit test)

n = Number of sensor supplies with activated short circuit test

Maximum response time with discrepancy error and 1oo2 evaluation

Maximum response time = T_{max} + Input delay + Discrepancy time + 2 × Maximum (short circuit test time for the sensor supply configured for channel 0, short circuit test time for the sensor supply configured for channel 1)

Maximum response time with error and change of user data

Maximum response time = $3 \times T_{cycle}$ + Maximum(dark test time, switch-on time)

Maximum response time with detection by bit pattern test

Maximum response time = T_{cycle} + Maximum(dark test time, switch-on time) + configured test time

Definition of response time for fail-safe digital outputs

The response time represents the interval between an incoming safety message frame from the backplane bus and the signal change at the digital output.

Maximum response time for fail-safe digital outputs

The maximum response time for fail-safe digital outputs in the error-free case is equal to:

Maximum response time = $2 \times T_{cycle}$ + Maximum(dark test time, switch-on time)

The maximum response time for fail-safe digital outputs in the presence of an error is equal to:

Maximum response time = T_{cycle} + $2 \times$ Maximum(dark test time, switch-on time) + interval between test pulses

A.2 Minimum distance of test pulses

The minimum interval between two test pulses depends on the activation of the light test, the configured maximum test time, and whether the output has been specified as a PM-switching or PP-switching output.

You can find the dependencies in the table below:

Assigned maximum test time	PM switching, light test not active	PM switching, light test active	PP switching, light test not active	PP switching, light test active
1000 s	62.080 s	45.147 s	82.913 s	38.137 s
100 s	5.830 s	4.238 s	7.913 s	3.521 s

Switching of loads

B.1 Connecting capacitive loads

If the output of power module F-PM-E 24VDC/8A PPM ST is interconnected with loads that require little current and have capacitance, this can lead to detection of a short circuit or overload. Reason: The capacitance cannot be sufficiently discharged or charged during the configured readback time of the bit pattern test.

The figure below shows typical curves for the assignable readback times representing the correlation between load resistance and switchable load capacitance at a supply voltage of 24 V DC.

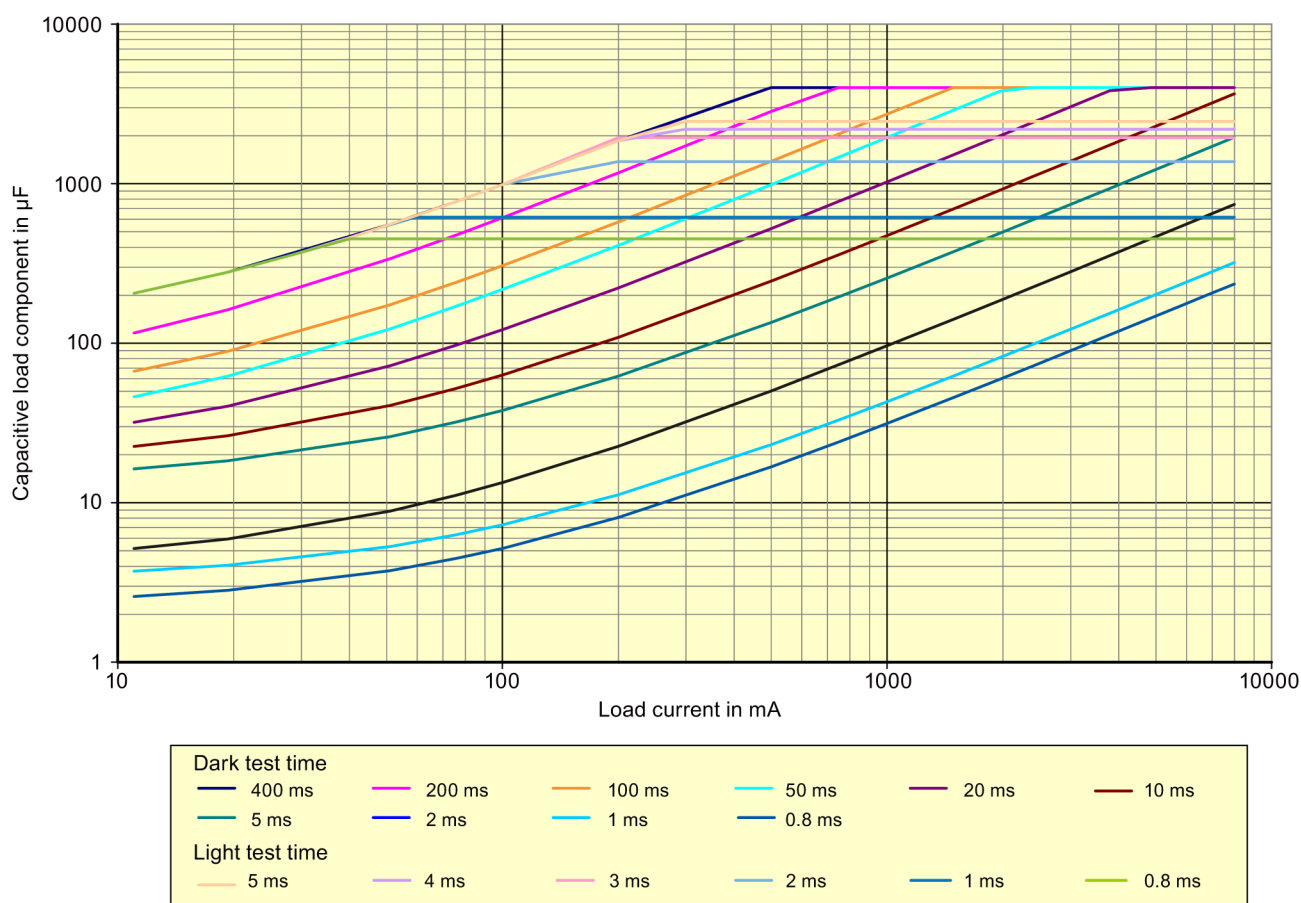

Figure B-1 Switching of capacitive loads for the F-PM-E 24VDC/8A PPM ST power module depending on the configured dark and light test times

The curves shown were plotted using a SIMATIC PS 307 10A power supply unit with a cable length of 25 m (cable cross-section of 1.5 mm²) between the output of the F-PM-E 24VDC/8A PPM ST power module and the load.

Remedy for detecting a short circuit

1. Determine the load current and capacitance of the load.
2. Locate the operating point in the diagram above.
3. If the operating point is above the curve, you must increase the load current until the new operating point is below the curve by connecting a resistor in parallel.

B.2 Switching of inductive loads

Switching of inductive loads

The diagram below shows the maximum permitted inductive loads as a function of the load current and switching frequency.

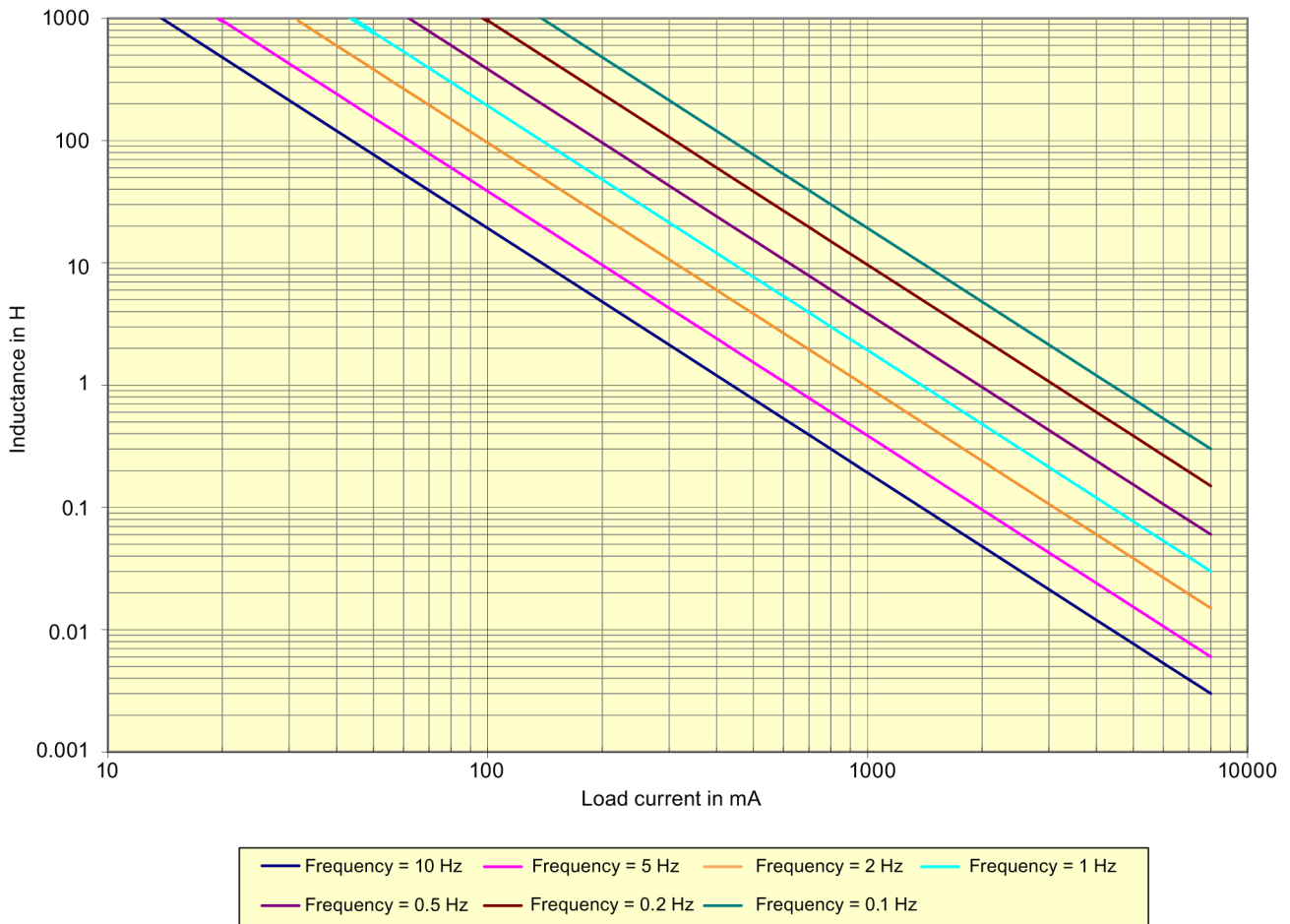

Figure B-2 Switching of inductive loads for the F-PM-E 24VDC/8A PPM ST power module depending on the load current and switching frequency