

**SIEMENS**



# SINAMICS

## SINAMICS G120 Inverters

PM240 Power Modules

Hardware Installation Manual

Edition

03/2017



# SIEMENS

## SINAMICS

### SINAMICS G120 PM240 Power Modules

#### Hardware Installation Manual

<u>Changes in this manual</u>	<b>1</b>
<u>Fundamental safety instructions</u>	<b>2</b>
<u>Introduction</u>	<b>3</b>
<u>Installing/mounting</u>	<b>4</b>
<u>Connecting-up</u>	<b>5</b>
<u>Service and maintenance</u>	<b>6</b>
<u>Technical data</u>	<b>7</b>
<u>Spare parts and accessories</u>	<b>8</b>
<u>Appendix</u>	<b>A</b>

03/2017



**03/2017**

A5E36985441C AB

## Legal information

### Warning notice system

This manual contains notices you have to observe in order to ensure your personal safety, as well as to prevent damage to property. The notices referring to your personal safety are highlighted in the manual by a safety alert symbol, notices referring only to property damage have no safety alert symbol. These notices shown below are graded according to the degree of danger.

 <b>DANGER</b>
indicates that death or severe personal injury <b>will</b> result if proper precautions are not taken.
 <b>WARNING</b>
indicates that death or severe personal injury <b>may</b> result if proper precautions are not taken.
 <b>CAUTION</b>
indicates that minor personal injury can result if proper precautions are not taken.
<b>NOTICE</b>
indicates that property damage can result if proper precautions are not taken.

If more than one degree of danger is present, the warning notice representing the highest degree of danger will be used. A notice warning of injury to persons with a safety alert symbol may also include a warning relating to property damage.

### Qualified Personnel

The product/system described in this documentation may be operated only by **personnel qualified** for the specific task in accordance with the relevant documentation, in particular its warning notices and safety instructions. Qualified personnel are those who, based on their training and experience, are capable of identifying risks and avoiding potential hazards when working with these products/systems.

### Proper use of Siemens products

Note the following:

 <b>WARNING</b>
Siemens products may only be used for the applications described in the catalog and in the relevant technical documentation. If products and components from other manufacturers are used, these must be recommended or approved by Siemens. Proper transport, storage, installation, assembly, commissioning, operation and maintenance are required to ensure that the products operate safely and without any problems. The permissible ambient conditions must be complied with. The information in the relevant documentation must be observed.

### Trademarks

All names identified by ® are registered trademarks of Siemens AG. The remaining trademarks in this publication may be trademarks whose use by third parties for their own purposes could violate the rights of the owner.

### Disclaimer of Liability

We have reviewed the contents of this publication to ensure consistency with the hardware and software described. Since variance cannot be precluded entirely, we cannot guarantee full consistency. However, the information in this publication is reviewed regularly and any necessary corrections are included in subsequent editions.

# Table of contents

<b>1</b>	<b>Changes in this manual</b> .....	<b>9</b>
<b>2</b>	<b>Fundamental safety instructions</b> .....	<b>11</b>
2.1	General safety instructions .....	11
2.2	Safety instructions for electromagnetic fields (EMF) .....	15
2.3	Handling electrostatic sensitive devices (ESD) .....	15
2.4	Industrial security .....	16
2.5	Residual risks of power drive systems.....	17
<b>3</b>	<b>Introduction</b> .....	<b>19</b>
3.1	PM240 Power Modules.....	19
3.2	Component specification according to UL .....	20
<b>4</b>	<b>Installing/mounting</b> .....	<b>21</b>
4.1	Installation conditions.....	21
4.2	EMC-compliant installation of a plant or machine .....	22
4.2.1	Control cabinet.....	22
4.2.2	Cables .....	24
4.2.3	Electromechanical components .....	27
4.3	Power losses and air cooling requirements .....	28
4.4	Mounting the Power Modules .....	30
4.4.1	Dimension drawings and drilling dimensions, FSA ... FSF .....	31
4.4.2	Dimensioned drawings and drilling dimensions, FSGX.....	33
4.5	Additional components.....	34
<b>5</b>	<b>Connecting-up</b> .....	<b>35</b>
5.1	Permissible line supplies .....	38
5.1.1	TN line system .....	38
5.1.2	TT line system.....	39
5.1.3	IT system .....	40
5.1.4	Protective conductor .....	41
5.2	Connecting the line and motor cable at the inverter .....	43
5.2.1	Connection overview.....	43
5.2.2	Connecting inverters in compliance with EMC regulations.....	44
5.2.3	Length of motor cable .....	44
5.2.4	Inverter terminals .....	46
5.2.5	Establishing connections .....	47
5.2.5.1	Connections FSA ... FSC.....	47
5.2.5.2	Connections FSD ... FSF .....	47
5.2.5.3	Connections FSGX .....	48
5.3	Connecting the motor to the inverter in a star or delta connection.....	50

<b>6</b>	<b>Service and maintenance</b> .....	<b>51</b>
6.1	Maintenance.....	52
6.2	Commissioning after a long storage time .....	53
6.3	Replace the fan .....	54
6.4	Replacing the FSGX power block .....	59
<b>7</b>	<b>Technical data</b> .....	<b>61</b>
7.1	Ambient conditions.....	61
7.2	Overload capability of the inverter .....	63
7.3	Cable cross-sections and tightening torques .....	65
7.4	General data .....	66
7.5	Specific technical data .....	66
7.5.1	Current derating depending on the pulse frequency.....	71
7.6	Restrictions for special ambient conditions.....	72
7.7	Electromagnetic compatibility of variable-speed drives .....	74
7.7.1	Inverter applications .....	76
7.7.1.1	Operation in the second environment.....	76
7.7.1.2	Operation in the first environment.....	78
7.7.2	Radio interference suppression filters according to CISPR 11/EN 55011 Class B .....	79
7.7.3	Harmonic currents.....	79
7.7.4	EMC limit values in South Korea .....	80
<b>8</b>	<b>Spare parts and accessories</b> .....	<b>81</b>
8.1	Product maintenance .....	81
8.2	Spare parts.....	81
8.3	Optional accessories.....	82
8.3.1	Base components for frame sizes FSA, FSB and FSC .....	82
8.3.2	Line reactor .....	84
8.3.3	Line filter.....	88
8.3.4	Output reactor .....	90
8.3.5	Sine-wave filter.....	94
8.3.6	Braking Module - only FSGX .....	98
8.3.6.1	Braking Module - settings and connections .....	99
8.3.7	Braking resistor .....	100
8.3.7.1	Connect the temperature contact of the braking resistor.....	104
8.3.8	Connecting a motor holding brake to a Safe Brake Relay.....	104
8.3.8.1	Mounting and connecting the brake relay .....	105
8.3.8.2	Mounting and connecting the Safe Brake Relay.....	106
8.3.8.3	Technical data of the brake relay? .....	106
8.3.8.4	Mounting and connecting the brake relay .....	107
8.3.9	For standard rail mounting .....	108
8.3.10	Shield connection kit .....	108
<b>A</b>	<b>Appendix</b> .....	<b>109</b>
A.1	Manuals and technical support .....	109
A.1.1	Overview of the manuals .....	109

A.1.2	Configuring support.....	111
A.1.3	Product Support .....	112
A.2	Disposal .....	112
A.3	Directives and standards .....	113
A.4	Abbreviations .....	115
<b>Index.....</b>		<b>117</b>



## Changes in this manual

### Changes with respect to the manual, Edition 07/2009

All chapters in the manual have been completely revised.

### Changes with respect to the manual, Edition 07/2016

Tables corrected.



Output reactor (Page 90)



## Fundamental safety instructions

### 2.1 General safety instructions



	<p><b>! DANGER</b></p> <p><b>Danger to life due to live parts and other energy sources</b></p> <p>Death or serious injury can result when live parts are touched.</p> <ul style="list-style-type: none"> <li>• Only work on electrical devices when you are qualified for this job.</li> <li>• Always observe the country-specific safety rules.</li> </ul> <p>Generally, six steps apply when establishing safety:</p> <ol style="list-style-type: none"> <li>1. Prepare for shutdown and notify all those who will be affected by the procedure.</li> <li>2. Disconnect the machine from the supply.               <ul style="list-style-type: none"> <li>– Switch off the machine.</li> <li>– Wait until the discharge time specified on the warning labels has elapsed.</li> <li>– Check that it really is in a no-voltage condition, from phase conductor to phase conductor and phase conductor to protective conductor.</li> <li>– Check whether the existing auxiliary supply circuits are de-energized.</li> <li>– Ensure that the motors cannot move.</li> </ul> </li> <li>3. Identify all other dangerous energy sources, e.g. compressed air, hydraulic systems, or water.</li> <li>4. Isolate or neutralize all hazardous energy sources by closing switches, grounding or short-circuiting or closing valves, for example.</li> <li>5. Secure the energy sources against switching on again.</li> <li>6. Ensure that the correct machine is completely interlocked.</li> </ol> <p>After you have completed the work, restore the operational readiness in the inverse sequence.</p>
--	---



	<p><b>! WARNING</b></p> <p><b>Danger to life through a hazardous voltage when connecting an unsuitable power supply</b></p> <p>Touching live components can result in death or severe injury.</p> <ul style="list-style-type: none"> <li>• Only use power supplies that provide SELV (Safety Extra Low Voltage) or PELV- (Protective Extra Low Voltage) output voltages for all connections and terminals of the electronics modules.</li> </ul>
--	--



 <b>WARNING</b>
<b>Danger to life when live parts are touched on damaged devices</b>
Improper handling of devices can cause damage.
For damaged devices, hazardous voltages can be present at the enclosure or at exposed components; if touched, this can result in death or severe injury.
<ul style="list-style-type: none"><li>• Ensure compliance with the limit values specified in the technical data during transport, storage and operation.</li><li>• Do not use any damaged devices.</li></ul>



 <b>WARNING</b>
<b>Danger to life through electric shock due to unconnected cable shields</b>
Hazardous touch voltages can occur through capacitive cross-coupling due to unconnected cable shields.
<ul style="list-style-type: none"><li>• As a minimum, connect cable shields and the conductors of power cables that are not used (e.g. brake cores) at one end at the grounded housing potential.</li></ul>



 <b>WARNING</b>
<b>Danger to life due to electric shock when not grounded</b>
For missing or incorrectly implemented protective conductor connection for devices with protection class I, high voltages can be present at open, exposed parts, which when touched, can result in death or severe injury.
<ul style="list-style-type: none"><li>• Ground the device in compliance with the applicable regulations.</li></ul>



 <b>WARNING</b>
<b>Danger to life due to electric shock when opening plug connections in operation</b>
When opening plug connections in operation, arcs can result in severe injury or death.
<ul style="list-style-type: none"><li>• Only open plug connections when the equipment is in a no-voltage state, unless it has been explicitly stated that they can be opened in operation.</li></ul>

<b>NOTICE</b>
<b>Material damage due to loose power connections</b>
Insufficient tightening torques or vibrations can result in loose electrical connections. This can result in damage due to fire, device defects or malfunctions.
<ul style="list-style-type: none"><li>• Tighten all power connections with the specified tightening torques, e.g. line supply connection, motor connection, DC link connections.</li><li>• Check all power connections at regular intervals. This applies in particular after transport.</li></ul>

 **WARNING****Danger to life due to fire spreading if housing is inadequate**

Fire and smoke development can cause severe personal injury or material damage.

- Install devices without a protective housing in a metal control cabinet (or protect the device by another equivalent measure) in such a way that contact with fire is prevented.
- Ensure that smoke can only escape via controlled and monitored paths.

 **WARNING****Danger to life through unexpected movement of machines when using mobile wireless devices or mobile phones**

Using mobile wireless devices or mobile phones with a transmit power > 1 W closer than approx. 2 m to the components may cause the devices to malfunction, influence the functional safety of machines therefore putting people at risk or causing material damage.

- Switch the wireless devices or mobile phones off in the immediate vicinity of the components.

 **WARNING****Danger to life due to the motor catching fire in the event of insulation overload**

There is higher stress on the motor insulation through a ground fault in an IT system. If the insulation fails, it is possible that death or severe injury can occur as a result of smoke and fire.

- Use a monitoring device that signals an insulation fault.
- Correct the fault as quickly as possible so the motor insulation is not overloaded.

 **WARNING****Danger to life due to fire if overheating occurs because of insufficient ventilation clearances**

Inadequate ventilation clearances can cause overheating of components with subsequent fire and smoke. This can cause severe injury or even death. This can also result in increased downtime and reduced service lives for devices/systems.

- Ensure compliance with the specified minimum clearance as ventilation clearance for the respective component.

 **WARNING**

**Danger of an accident occurring due to missing or illegible warning labels**

Missing or illegible warning labels can result in accidents involving death or serious injury.

- Check that the warning labels are complete based on the documentation.
- Attach any missing warning labels to the components, in the national language if necessary.
- Replace illegible warning labels.

**NOTICE**

**Device damage caused by incorrect voltage/insulation tests**

Incorrect voltage/insulation tests can damage the device.

- Before carrying out a voltage/insulation check of the system/machine, disconnect the devices as all converters and motors have been subject to a high voltage test by the manufacturer, and therefore it is not necessary to perform an additional test within the system/machine.

 **WARNING**

**Danger to life when safety functions are inactive**

Safety functions that are inactive or that have not been adjusted accordingly can cause operational faults on machines that could lead to serious injury or death.

- Observe the information in the appropriate product documentation before commissioning.
- Carry out a safety inspection for functions relevant to safety on the entire system, including all safety-related components.
- Ensure that the safety functions used in your drives and automation tasks are adjusted and activated through appropriate parameterizing.
- Perform a function test.
- Only put your plant into live operation once you have guaranteed that the functions relevant to safety are running correctly.

---

**Note**

**Important safety notices for Safety Integrated functions**

If you want to use Safety Integrated functions, you must observe the safety notices in the Safety Integrated manuals.

---

## 2.2 Safety instructions for electromagnetic fields (EMF)



### WARNING

#### Danger to life from electromagnetic fields

Electromagnetic fields (EMF) are generated by the operation of electrical power equipment such as transformers, converters or motors.

People with pacemakers or implants are at a special risk in the immediate vicinity of these devices/systems.

- Ensure that the persons involved are the necessary distance away (minimum 2 m).

## 2.3 Handling electrostatic sensitive devices (ESD)

Electrostatic sensitive devices (ESD) are individual components, integrated circuits, modules or devices that may be damaged by either electric fields or electrostatic discharge.



### NOTICE

#### Damage through electric fields or electrostatic discharge

Electric fields or electrostatic discharge can cause malfunctions through damaged individual components, integrated circuits, modules or devices.

- Only pack, store, transport and send electronic components, modules or devices in their original packaging or in other suitable materials, e.g. conductive foam rubber or aluminum foil.
- Only touch components, modules and devices when you are grounded by one of the following methods:
  - Wearing an ESD wrist strap
  - Wearing ESD shoes or ESD grounding straps in ESD areas with conductive flooring
- Only place electronic components, modules or devices on conductive surfaces (table with ESD surface, conductive ESD foam, ESD packaging, ESD transport container).

## 2.4 Industrial security

### Note

#### Industrial security

Siemens provides products and solutions with industrial security functions that support the secure operation of plants, solutions, machines, equipment and/or networks. They are important components in a holistic industrial security concept. With this in mind, Siemens' products and solutions undergo continuous development. Siemens recommends strongly that you regularly check for product updates.

For the secure operation of Siemens products and solutions, it is necessary to take suitable preventive action (e.g. cell protection concept) and integrate each component into a holistic, state-of-the-art industrial security concept. Third-party products that may be in use should also be considered. For more information about industrial security, visit this address (<http://www.siemens.com/industrialsecurity>).

To stay informed about product updates as they occur, sign up for a product-specific newsletter. For more information, visit this address (<http://support.automation.siemens.com>).

### WARNING

#### **Danger as a result of unsafe operating states resulting from software manipulation**

Software manipulation (e.g. by viruses, Trojan horses, malware, worms) can cause unsafe operating states to develop in your installation which can result in death, severe injuries and/or material damage.

- Keep the software up to date.  
You will find relevant information and newsletters at this address (<http://support.automation.siemens.com>).
- Incorporate the automation and drive components into a holistic, state-of-the-art industrial security concept for the installation or machine.  
You will find further information at this address (<http://www.siemens.com/industrialsecurity>).
- Make sure that you include all installed products into the holistic industrial security concept.

### WARNING

#### **Danger to life due to software manipulation when using exchangeable storage media**

Storing files onto exchangeable storage media amounts to an increased risk of infection, e.g. with viruses and malware. As a result of incorrect parameterization, machines can malfunction, which in turn can lead to injuries or death.

- Protect files stored on exchangeable storage media from malicious software by taking suitable protection measures, e.g. virus scanners.

## 2.5 Residual risks of power drive systems

When assessing the machine- or system-related risk in accordance with the respective local regulations (e.g., EC Machinery Directive), the machine manufacturer or system installer must take into account the following residual risks emanating from the control and drive components of a drive system:

1. Unintentional movements of driven machine or system components during commissioning, operation, maintenance, and repairs caused by, for example,
  - Hardware and/or software errors in the sensors, control system, actuators, and cables and connections
  - Response times of the control system and of the drive
  - Operation and/or environmental conditions outside the specification
  - Condensation/conductive contamination
  - Parameterization, programming, cabling, and installation errors
  - Use of wireless devices/mobile phones in the immediate vicinity of electronic components
  - External influences/damage
  - X-ray, ionizing radiation and cosmic radiation
2. Unusually high temperatures, including open flames, as well as emissions of light, noise, particles, gases, etc., can occur inside and outside the components under fault conditions caused by, for example:
  - Component failure
  - Software errors
  - Operation and/or environmental conditions outside the specification
  - External influences/damage
3. Hazardous shock voltages caused by, for example:
  - Component failure
  - Influence during electrostatic charging
  - Induction of voltages in moving motors
  - Operation and/or environmental conditions outside the specification
  - Condensation/conductive contamination
  - External influences/damage
4. Electrical, magnetic and electromagnetic fields generated in operation that can pose a risk to people with a pacemaker, implants or metal replacement joints, etc., if they are too close
5. Release of environmental pollutants or emissions as a result of improper operation of the system and/or failure to dispose of components safely and correctly

For more information about the residual risks of the drive system components, see the relevant sections in the technical user documentation.



# Introduction

## 3.1 PM240 Power Modules

### Overview

The PM240 Power Modules belong to the modular family of SINAMICS G120 inverters. A modular inverter comprises Control Unit and Power Module.

The PM240 Power Modules are designed for line voltages of 3 AC 380 V ... 480 V. Depending on the power rating, they are supplied in frame sizes FSA ... FSGX.

- FSA 0.37 kW ... 1.5 kW
- FSB 2.2 kW ... 4 kW
- FSC 7.5 kW ... 15 kW
- FSD 18.5 kW ... 30 kW
- FSE 37 kW ... 45 kW
- FSF 55 kW ... 132 kW
- FSGX 160 kW ... 240 kW

The power data refer to Low Overload operation.



Overload capability of the inverter (Page 63)

### Permissible power range of the motors

For the Power Modules, induction motors are permissible in the range from 25 % ... 150 % of the inverter power without any restrictions.

### Control Units for the PM240 Power Modules

You can operate the Power Modules with one of the following Control Units.

- CU230P-2 FSGX from V4.3, all other frame sizes without any restriction
- CU240B-2
- CU240E
- CU240E-2
- CU240S
- CU250S-2

---

**Note**

**Commissioning the inverter**

You must first commission the inverter before you can use it. Commissioning is described in the operating instructions of the relevant Control Unit.



Overview of the manuals (Page 109)

---

## 3.2 Component specification according to UL

The components of the SINAMICS G120 product family are UL-certified. The certification is indicated on the products using the UL Listing Mark.

If the inverter is protected using semiconductor fuses, then the fuses must be installed in the same electrical cabinet as the inverter itself.



You can find proof of the certification on the Internet UL certificates (<http://www.ul.com>) under "Tools / Online Certifications Directory" by entering the file number or the "Name".

The UL file number for the Power Modules of the SINAMICS G120 product family is:



- E121068 for FSA, FSB and FSC
- E192450 for FSD, FSE, FSF and FSGX

# Installing/mounting

## 4.1 Installation conditions

### General installation conditions

When installing the Power Modules carefully observe the conditions listed below in order to guarantee reliable, continuous and disturbance-free operation.

- The Power Modules are designed for installation in a control cabinet.
- The Power Modules are certified for use in environments with degree of pollution 2 without condensation; i.e. in environments where no conductive pollution/dirt occurs. Condensation is not permissible.
- Built-in units FSA ... FSC have degree of protection IP20.
- Built-in units FSD ... FSF have degree of protection IPxxB.
- Devices with push-through technology have degree of protection IP20, to the rear of the control cabinet, IP55.
- You can find the permissible terminal cross-sections in:
  -  Cable cross-sections and tightening torques (Page 65) .
- The following section describes how you can install the Power Modules in compliance with EMC regulations:
  -  EMC-compliant installation of a plant or machine (Page 22).

### Inverters for systems in the United States / Canada (UL/cUL)

- For configurations in conformance with UL/cUL, use the UL/cUL-approved fuses, Class J or Siemens 3NE1 semiconductor fuses, which are specified in this manual.
 

Permissible fuse types and characteristic values:  Technical data (Page 61).
- Only use copper cables for 75 °C for frame sizes FSA ... FSC.
- Only use copper cables rated for 60 °C or 75 °C for frame sizes FSD ... FSGX.
- The integrated solid state short circuit protection does not provide cable protection. On the system side, provide cable protection in conformance with NEC or CEC, Part 1 and the local regulations.
- The inverter features internal motor overload protection corresponding to UL508C. The protection threshold is 115 % of the inverter full load current. When commissioning, you can adapt the motor overload protection using parameter p0640.

## 4.2 EMC-compliant installation of a plant or machine

### 4.2.1 Control cabinet

The inverter is designed for operation in industrial environments where high-level electromagnetic fields are to be expected.

Reliable and disturbance-free operation of the inverter is only ensured if the inverter is installed in compliance with EMC regulations.

#### EMC zones within the control cabinet

- Subdivide the control cabinet and the machine or plant into EMC zones:

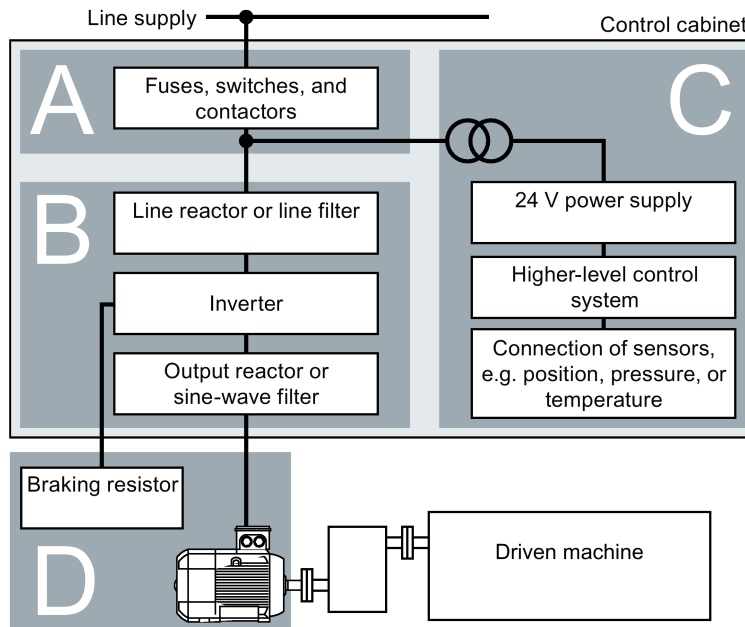

Figure 4-1 Example of the EMC zones of a plant or machine

- Zone A: Line supply connection
- Zone B: Power electronics  
Devices in Zone B generate energy-rich electromagnetic fields.
- Zone C: Control and sensors  
Devices in Zone C do not generate any energy-rich electromagnetic fields themselves, but their functions can be impaired by electromagnetic fields.
- Zone D: Motors, braking resistors outside the control cabinet  
Devices in Zone D generate electromagnetic fields with a significant amount of energy

- Electromagnetically uncouple the zones from each other by means of one of the following actions:
  - Side clearance  $\geq 25$  cm
  - Separate metal enclosure
  - Large-area partition plates
- Assign the various devices to zones in the control cabinet.
- Route cables of various zones in separate cable harnesses or cable ducts.
- Install filters or isolation amplifiers at the interfaces of the zones.

### Control cabinet assembly

- Connect the door, side panels, top and base plate of the control cabinet with the control cabinet frame using one of the following methods:
  - Electrical contact surface of several  $\text{cm}^2$  for each contact location
  - Several screw connections
  - Short, finely stranded, braided copper wires with cross-sections  $\geq 95 \text{ mm}^2 / 000 (3/0) (-2)$  AWG
- Install a shield support for shielded cables that are routed out of the control cabinet.
- Connect the PE bar and the shield support to the control cabinet frame through a large surface area to establish a good electrical connection.
- Mount the control cabinet components on a bare metal mounting plate.
- Connect the mounting plate to the control cabinet frame and PE bar and shield support through a large surface area to establish a good electrical connection.
- For screw connections onto painted or anodized surfaces, establish a good conductive contact using one of the following methods:
  - Use special (serrated) contact washers that cut through the painted or anodized surface.
  - Remove the insulating coating at the contact locations.

### Measures required for several control cabinets

- Install equipotential bonding for all control cabinets.
- Screw the frames of the control cabinets together at several locations through a large surface area using serrated washers to establish a good electrical connection.
- In plants and systems where the control cabinets are lined up next to one another, and which are installed in two groups back to back, connect the PE bars of the two cabinet groups at as many locations as possible.

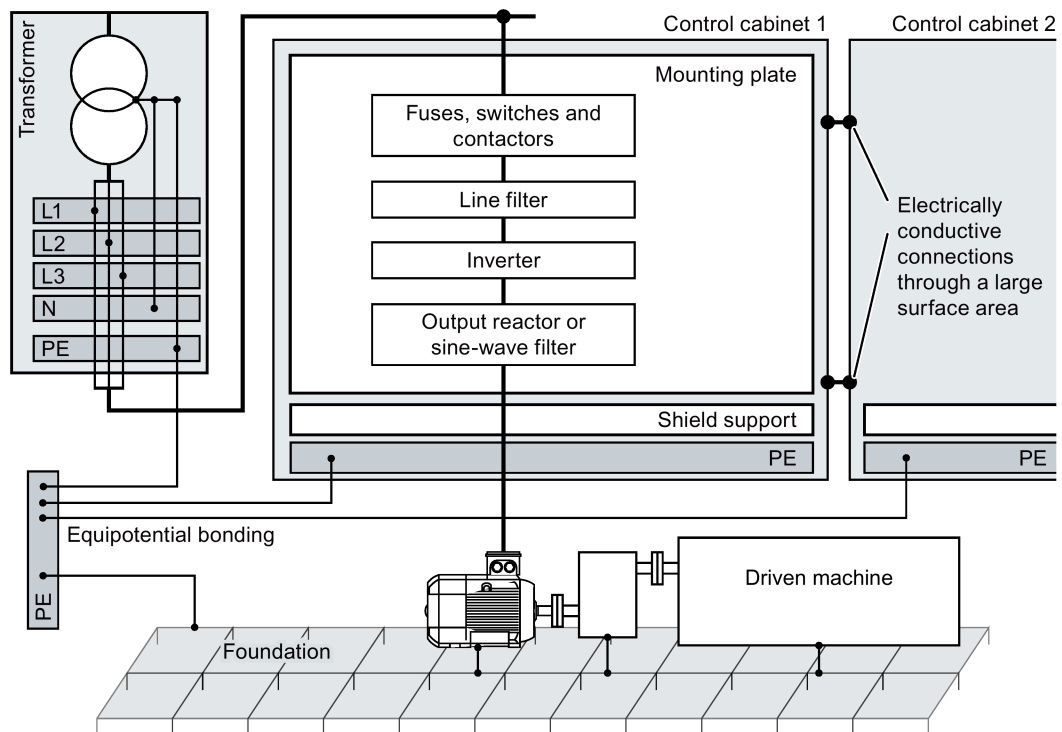

Figure 4-2 Grounding and high-frequency equipotential bonding measures in the control cabinet and in the plant/system

### Further information



Additional information about EMC-compliant installation is available in the Internet:

EMC installation guideline (<http://support.automation.siemens.com/WW/view/en/60612658>)

### 4.2.2 Cables

Cables with a high level of interference and cables with a low level of interference are connected to the inverter:

- Cables with a high level of interference:
  - Cable between the line filter and inverter
  - Motor cable
  - Cable at the inverter DC link connection
  - Cable between the inverter and braking resistor
- Cables with a low level of interference:
  - Cable between the line and line filter
  - Signal and data cables

### Cable routing inside the cabinet

- Route the power cables with a high level of interference so that there is a minimum clearance of 25 cm to cables with a low level of interference.

If the minimum clearance of 25 cm is not possible, insert separating metal sheets between the cables with a high level of interference and cables with a low level of interference. Connect these separating metal sheets to the mounting plate to establish a good electrical connection.

- Cables with a high level of interference and cables with a low level of interference may only cross over at right angles:
- Keep all of the cables as short as possible.
- Route all of the cables close to the mounting plates or cabinet frames.
- Route signal and data cables - as well as the associated equipotential bonding cables - parallel and close to one another.
- Twist incoming and outgoing unshielded individual conductors.

Alternatively, you can route incoming and outgoing conductors in parallel, but close to one another.

- Ground any unused conductors of signal and data cables at both ends.
- Signal and data cables must only enter the cabinet from one side, e.g. from below.
- Using shielded cables for the following connections:
  - Cable between the inverter and line filter
  - Cable between the inverter and output reactor or sine-wave filter

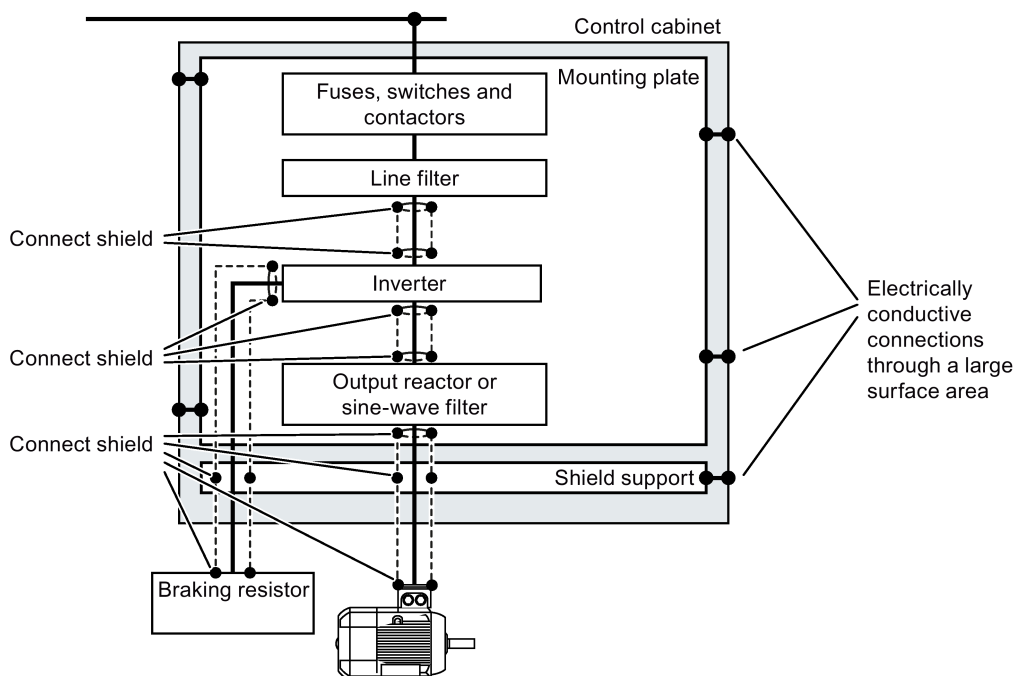

Figure 4-3 Routing inverter cables inside and outside a control cabinet

### Routing cables outside the control cabinet

- Maintain a minimum clearance of 25 cm between cables with a high level of interference and cables with a low level of interference.
- Using shielded cables for the following connections:
  - Inverter motor cable
  - Cable between the inverter and braking resistor
  - Signal and data cables
- Connect the motor cable shield to the motor enclosure using a PG gland that establishes a good electrical connection.

### Requirements relating to shielded cables

- Use cables with finely-stranded, braided shields.
- Connect the shield to at least one end of the cable.

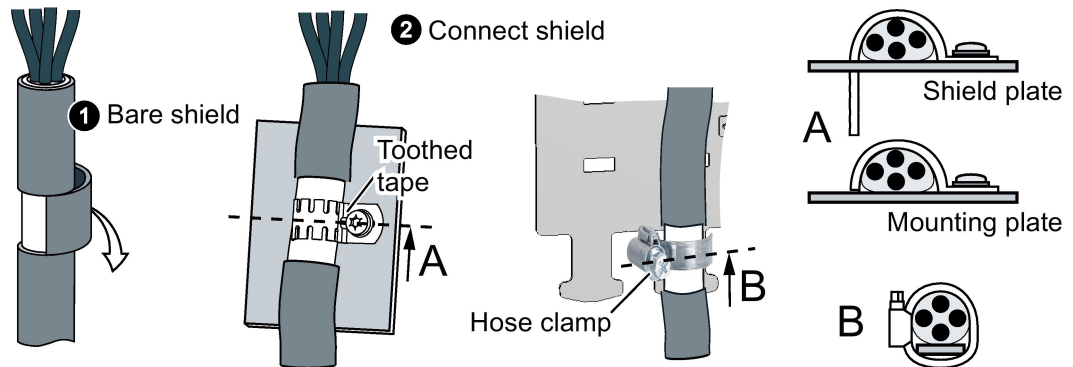

Figure 4-4 Examples for EMC-compliant shield support

- Attach the shield to the shield support directly after the cable enters the cabinet.
- Do not interrupt the shield.
- Only use metallic or metallized plug connectors for shielded data cables.

## **4.2.3 Electromechanical components**

### **Radio interference suppression**

- Connect interference suppression elements to the following components:
  - Coils of contactors
  - Relays
  - Solenoid valves
  - Motor holding brakes
- Connect the interference suppression element directly at the coil.
- Use RC elements or varistors for AC-operated coils and freewheeling diodes or varistors for DC-operated coils.

## 4.3 Power losses and air cooling requirements

### Cooling requirements

Depending on the power loss of the individual components, the control cabinet will require a cooling airflow to prevent the components from overheating.

Formula for calculating the cooling airflow:

$$\text{Air flow [l/s]} = \frac{\text{Power loss [W]}}{\Delta T \text{ [K]}} * 0.86$$

- Power loss: Total of the power losses of the individual components.
- $\Delta T$  Permissible temperature rise in the electrical cabinet

### Measures in order to ensure that the components are adequately cooled

1. Add the power losses of the individual components.
  - Power Module data:  "Technical data (Page 61)".
  - The Control Unit power loss is less than 0.04 kW.
  - Use the manufacturers data for components, for example reactors or filters
2. Calculate the air flow required, using the formula above.
3. Ensure that the control cabinet is appropriately ventilated and equipped with suitable air filters.
4. Ensure that the components have the specified clearances with respect to one another.
5. Ensure that the components are provided with adequate cooling air through the cooling openings.
6. Use the appropriate air barriers to prevent cooling air short circuits

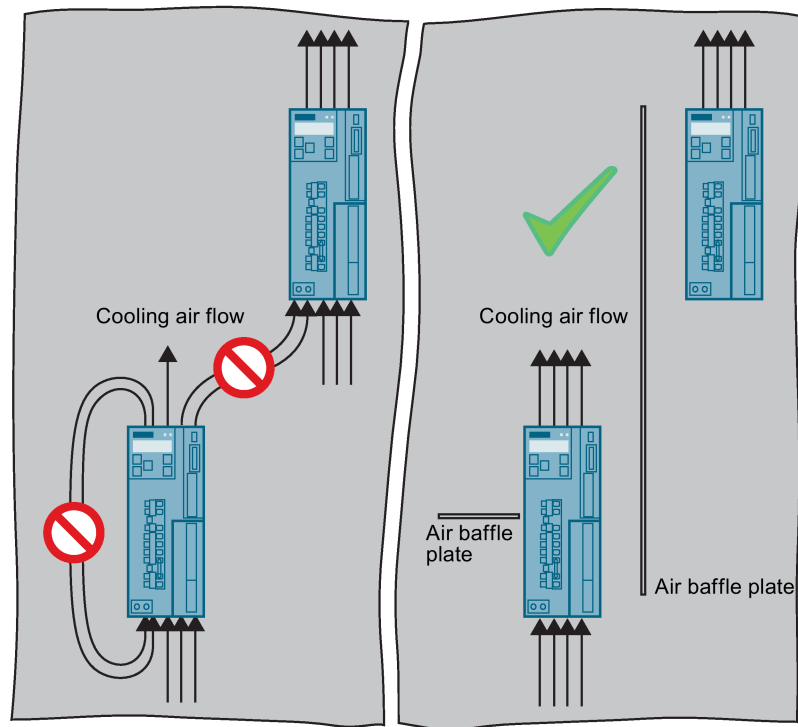

Figure 4-5 Air barriers for avoiding cooling air short circuits

## 4.4 Mounting the Power Modules

### Protection against the spread of fire

The device may be operated only in closed housings or in control cabinets with protective covers that are closed, and when all of the protective devices are used. The installation of the device in a metal control cabinet or the protection with another equivalent measure must prevent the spread of fire and emissions outside the control cabinet.

### Protection against condensation or electrically conductive contamination

Protect the device, e.g. by installing it in a control cabinet with degree of protection IP54 according to IEC 60529 or NEMA 12. Further measures may be necessary for particularly critical operating conditions.

If condensation or conductive pollution can be excluded at the installation site, a lower degree of control cabinet protection may be permitted.

### Installing Power Modules

The following is required to correctly install a Power Module:

- Install the Power Module vertically with the motor connections facing downwards.

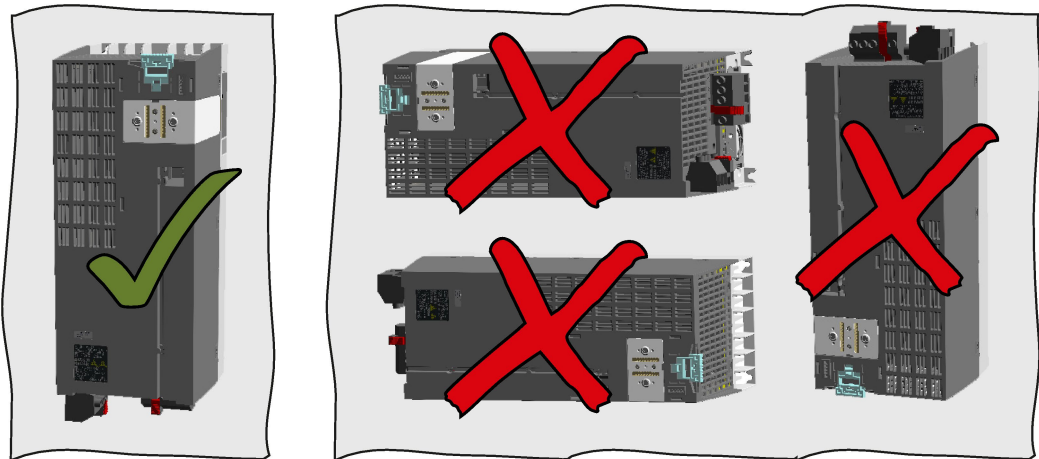

- Comply with the installation regulations specified in the following sections:
  - Minimum clearances to other components
  - Fixing elements
  - Tightening torques for fixing elements

### 4.4.1 Dimension drawings and drilling dimensions, FSA ... FSF

The following dimensioned drawings and drilling patterns are not to scale.

Table 4- 1 Installation dimensions without Control Unit (CU) [mm]

Frame size	Width <sup>1)</sup>	Height		Depth
		without shield plate	with shield plate	
FSA	73	173	271	145
FSB	153	270	360	165
FSC	189	334	432	185
FSD without filter	275	419	542	204
FSD with filter	275	512	635	204
FSE without filter	275	499	622	204
FSE with filter	275	635	758	204
FSF without filter	350	634	792	316
FSF with filter	350	934	1092	316

<sup>1)</sup> You can mount the Power Modules next to one another. For tolerance reasons, we recommend a lateral clearance of approx. 1 mm.

The following dimension drawings and drilling patterns are not to scale.

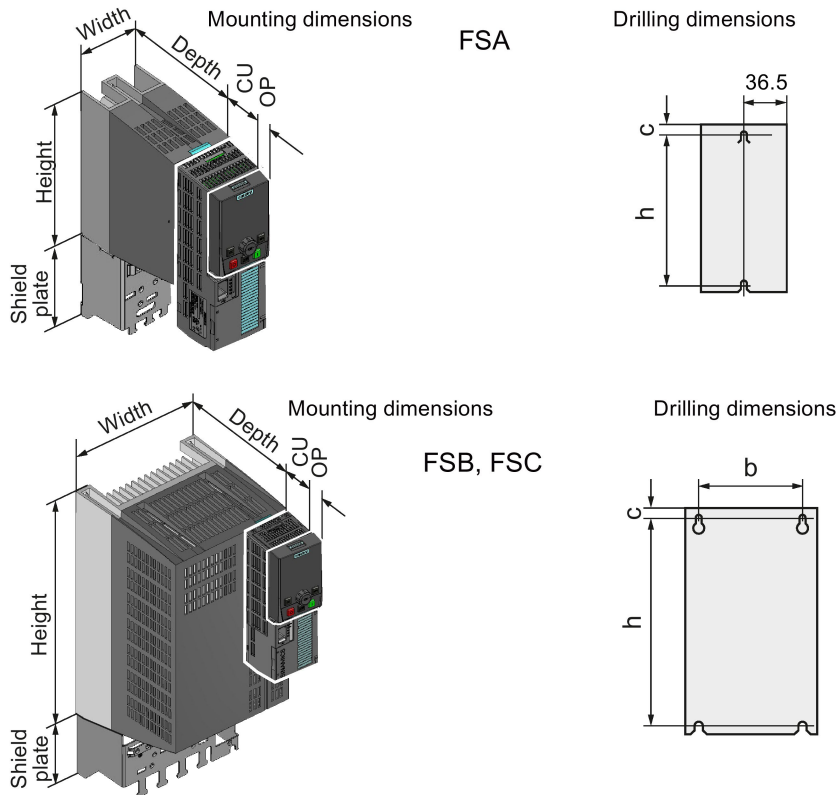

4.4 Mounting the Power Modules

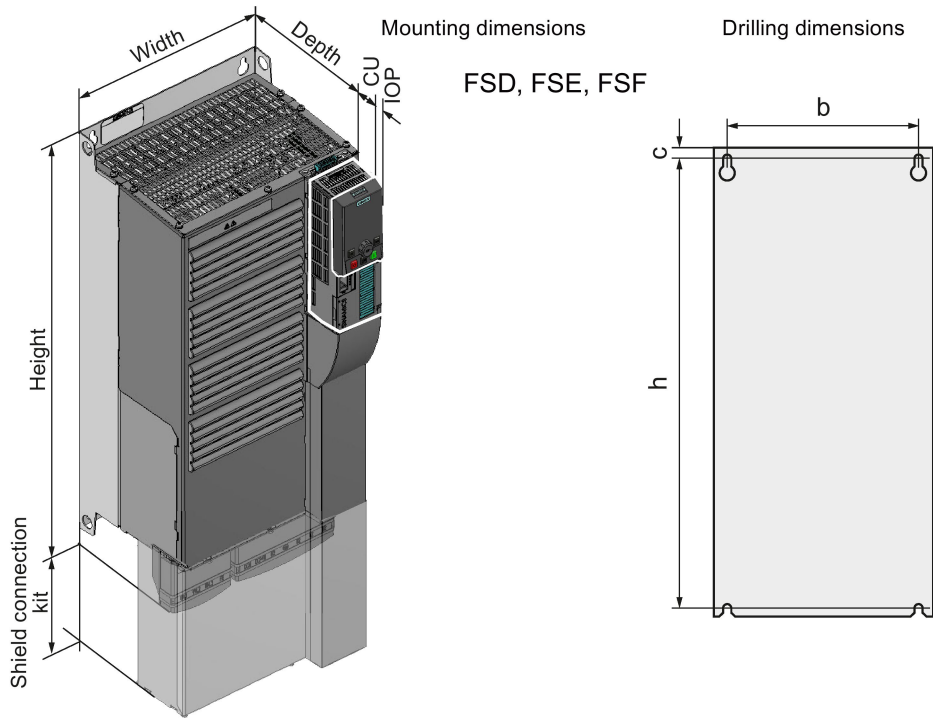

Table 4- 2 Depth with Control Unit and operator panel

Depth (mm) with ...	CU230P-2	CU240B/E-2	CU250S-2
... Control Unit:	+ 59	+ 41	+ 62
... Control Unit and blanking cover / BOP-2:	+ 70	+ 52	+ 73
... Control Unit and IOP:	+ 81	+ 63	+ 84

Table 4- 3 Drilling dimensions, cooling air clearances [mm] and fixing [Nm]

Frame size	Drilling dimensions			Cooling air clearances			Mounting
	b	h	c	Top	Bottom	Front	Screws/torque
FSA	36.5	160	7.5	100	100	65	2 x M4 / 2.5
FSB	133	258	5.5	100	100	65	4 x M4 / 2.5
FSC	167	323	6	125	125	65	4 x M5 / 3
FSD without filter	235	325	11	300	300	65	4 x M6 / 6
FSD with filter	235	419	11	300	300	65	4 x M6 / 6
FSE without filter	235	405	11	300	300	65	4 x M6 / 6
FSE with filter	235	541	11	300	300	65	4 x M6 / 6
FSF without filter	300	598	11	350	350	65	4 x M8 / 13
FSF with filter	300	898	11	350	350	65	4 x M8 / 13

## 4.4.2 Dimensioned drawings and drilling dimensions, FSGX

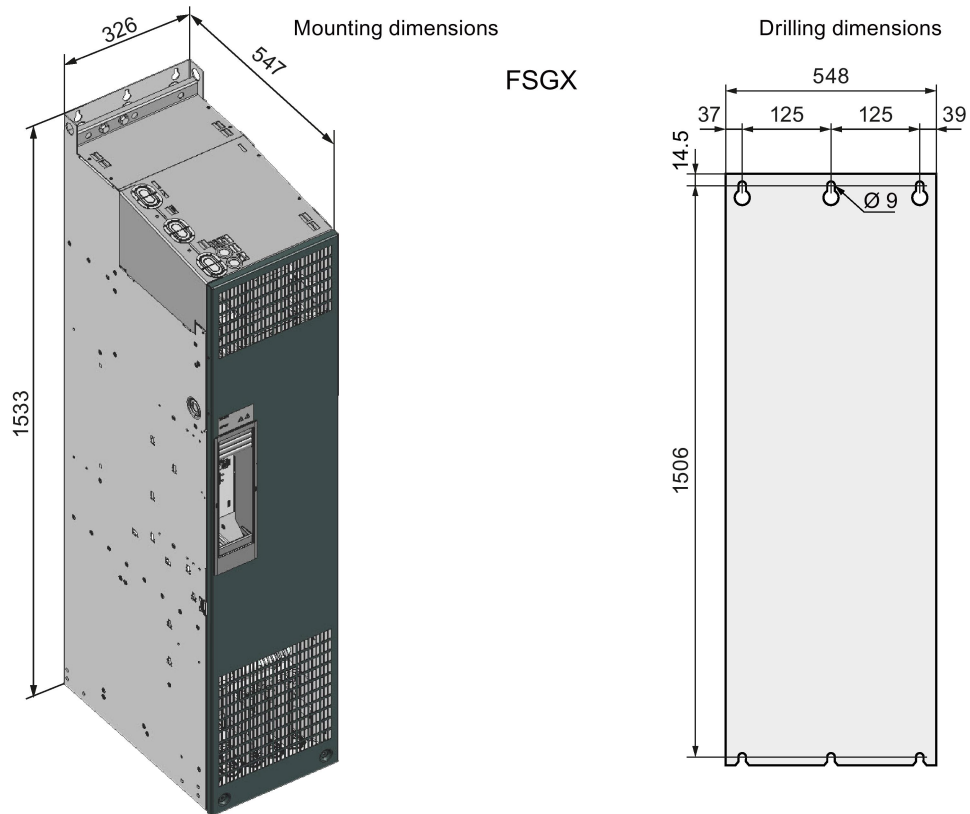

Mount the Power Module with the following clearances to other devices:

- Top: 250 mm
- Bottom: 150 mm
- Lateral: no clearance required for thermal reasons.

Fasten the Power Module with six M8 screws with a tightening torque of 13 Nm.

### Hoisting gear

When mounting Power Modules FSD, FSE, FSF and FSGX, use the holes marked to attach hoisting gear.

Weight of the Power Modules: 

Technical data (Page 61).

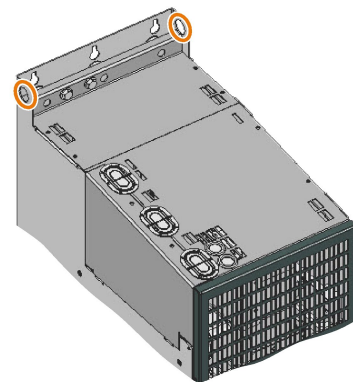

## 4.5 Additional components

Depending on the particular application, additional components may be required for your system. Information about additional components is provided in the following Sections:



Connection overview (Page 43)



Optional accessories (Page 82).

Install the inverters so that you are compliant with local regulations for erecting and installing low voltage systems.

 Fundamental safety instructions (Page 11)



## DANGER

### **Danger to life through electric shock due to the residual charge of the DC link capacitors**

Because of the DC link capacitors, a hazardous voltage is present for up to 5 minutes after the power supply has been switched off.

Contact with live parts can result in death or serious injury.

- Do not open the protective covers or the terminal covers of the device until 5 minutes have elapsed.
- Before starting any work, check that the system is in a voltage-free state by measuring all terminals, also to ground.
- Ensure that the associated warning plate in the appropriate language is attached.

---

## Note

### **Operating displays for inverter operation**

If, when switching over a function from ON to OFF, an LED or other similar display is not lit or not active; this does not indicate that the device is switched-off or in a no-current condition.

---

## Note

### **Safety devices**

Install suitable protective equipment between the line supply and inverter.

 Technical data (Page 61)



To protect against indirectly touching part of the motor circuit of an inverter and to automatically shut down in the case of a fault according to DIN EN 60364-4-41 (VDE 0100-410). (<http://support.automation.siemens.com/WW/view/en/103474630>)

 **WARNING**

**Danger to life due to fire or electric shock when using unsuitable residual current protection devices**

The inverter can cause a current to flow in the protective conductor. This current can cause the residual current device (RCD) or residual current monitoring (RCM) to incorrectly trip (nuisance trip). In the case of a fault (ground fault), the fault current can contain a DC component, which prevents the RCD/RCM from tripping, with the risk of subsequent fault or electric shock.

- Use the protection and monitoring devices recommended in the documentation.



 **CAUTION**

**Risk of injury due to hot surfaces**

During operation and for a short time after the inverter shuts down, the surface of the device can reach a high temperature.

- During this time, avoid any direct contact with the surface of the inverter.

## Protection and monitoring equipment

To provide protection against short-circuit, use the overcurrent devices listed in Technical data (fuses, circuit breakers etc.).

If the apparent impedance of the line supply at the infeed point is not suitable, so that fuses do not rupture in the specified time in the case of insulation failure (ground fault, fault to frame), then you must use additional fault current protective devices RCD (RCCB or MRCD), Type B.

In order that an RCD does not unnecessarily trip as a result of operational leakage currents, the following preconditions must be fulfilled:

- The neutral point of the line supply is grounded.
- For inverters with rated input currents  $\leq 125$  A referred to LO, use an RCCB type B with a response limit current of 300 mA. Connect the RCCB in series with the overcurrent protective devices.

- For inverters with rated input currents > 125 A referred to LO, use a type B MRCD (for example, from the Bender company).  
An MRCD comprises an RCM (differential current monitoring device), a measuring current transducer and a circuit breaker with additional undervoltage release, listed in the Technical data. An example of an MRCD design is provided in the following diagram.

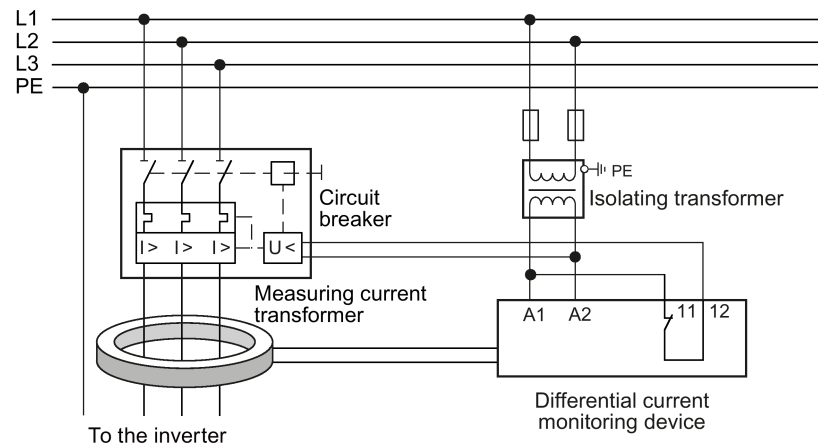



Figure 5-1 MRCD

- A dedicated RCD is used for every inverter.
- The motor cables are shorter than 50 m (164 ft) shielded, or 100 m (328 ft) unshielded.  
 Length of motor cable (Page 44)

## 5.1 Permissible line supplies

**Note**

**Restrictions for installation altitudes above 2000 m**

Above an installation altitude of 2000 m, the permissible line supplies are restricted.



Restrictions for special ambient conditions (Page 72)

**Note**

**Line requirement**

The machine manufacturer must ensure that in operation the voltage drop between the transformer input terminals and the inverter when operated with its rated values is less than 1%.

The inverter is designed for the following power distribution systems according to IEC 60364-1 (2005).

### 5.1.1 TN line system

A TN line system transfers the PE protective conductor to the installed plant or system using a cable.

Generally, in a TN line system the neutral point is grounded. There are versions of a TN system with a grounded line conductor, e.g. with grounded L1.

A TN line system can transfer the neutral conductor N and the PE protective conductor either separately or combined.

Example: separate transfer of N and PE,  
Grounded neutral point

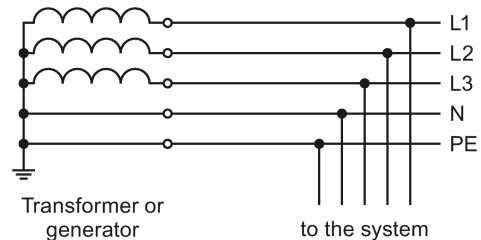

#### Inverter operated on a TN line system

- Inverter with integrated or external line filter:
  - Operation on TN line systems with grounded neutral point permissible.
  - Operation on TN line systems with grounded line conductor not permissible.
- Inverter without line filter:
  - Operation permissible on all TN line systems.

## 5.1.2 TT line system

In a TT line system, the transformer grounding and the installation grounding are independent of one another.

There are TT line supplies where the neutral conductor N is either transferred – or not.

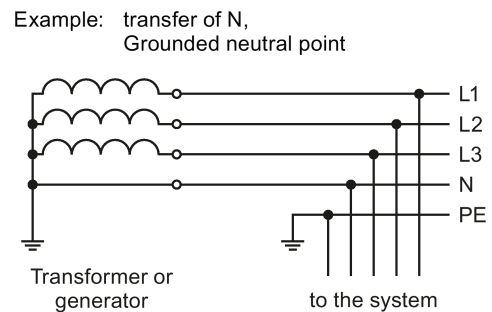

### Inverter operated on a TT line system

- Inverter with integrated or external line filter:
  - Operation on TT line systems with grounded neutral point permissible.
  - Operation on TT line systems without grounded neutral point not permissible.
- Inverter without line filter:
  - Operation on all TT line systems permissible.
- For installations in compliance with IEC, operation on a TT line system is permissible. For installations in compliance with UL, operation on a TT line system is not permissible.

### 5.1.3 IT system

In an IT line system, all of the conductors are insulated with respect to the PE protective conductor – or connected to the PE protective conductor through an impedance.

There are IT systems with and without transfer of the neutral conductor N.

Example: transfer of N, Impedance with respect to PE protective conduct

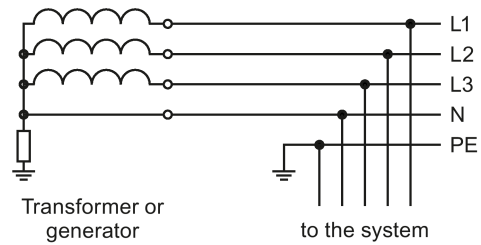

#### Inverter operated on an IT line system

- Inverters with integrated line filter:
  - Operation on IT line systems not permissible.
- Inverter without line filter:
  - Operation on all IT line systems permissible.

#### Behavior of the inverter when a ground fault occurs

In some instances, even for a ground fault, the inverter should still remain functional. In cases such as these, you must install an output reactor. This prevents an overcurrent trip or damage to the drive.

## 5.1.4 Protective conductor



### WARNING

#### Danger to life caused by high leakage currents for an interrupted protective conductor

The drive components conduct a high leakage current via the protective conductor. Touching conductive parts when the protective conductor is interrupted can result in death or serious injury.

- Dimension the protective conductor as stipulated in the appropriate regulations.

### Dimensioning the protective conductor

Observe the local regulations for protective conductors subject to an increased leakage current at the site of operation.

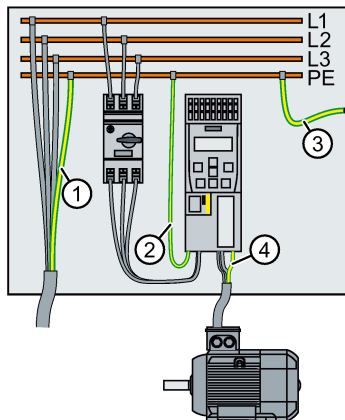

- ① Protective conductor for line feeder cables
- ② Protective conductor for inverter line feeder cables
- ③ Protective conductor between PE and the electrical cabinet
- ④ Protective conductor for motor feeder cables

The minimum cross-section of the protective conductor ① ... ④ depends on the cross-section of the line or motor feeder cable:

- Line or motor feeder cable  $\leq 16 \text{ mm}^2$   
⇒ Minimum cross-section of the protective conductor = cross-section of the line or motor feeder cable
- $16 \text{ mm}^2 < \text{line or motor feeder cable} \leq 35 \text{ mm}^2$   
⇒ Minimum cross-section of the protective conductor =  $16 \text{ mm}^2$
- Line or motor feeder cable  $> 35 \text{ mm}^2$   
⇒ Minimum cross-section of the protective conductor =  $\frac{1}{2}$  cross-section of the line or motor feeder cable

Additional requirements placed on the protective conductor ①:

- For permanent connection, the protective conductor must fulfill at least one of the following conditions:
  - The protective conductor is routed so that it is protected against damage along its complete length.  
Cables routed inside electrical cabinets or enclosed machine housings are considered to be adequately protected against mechanical damage.
  - As a conductor of a multi-conductor cable, the protective conductor has a cross-section  $\geq 2.5 \text{ mm}^2 \text{ Cu}$ .
  - For an individual conductor, the protective conductor has a cross-section  $\geq 10 \text{ mm}^2 \text{ Cu}$ .
  - The protective conductor consists of two conductors with the same cross-section.
- When connecting a multi-core cable using an industrial plug connector according to EN 60309, the protective conductor must have a cross-section of  $\geq 2.5 \text{ mm}^2 \text{ Cu}$ .

## 5.2 Connecting the line and motor cable at the inverter

### 5.2.1 Connection overview

**Note**

**Base components**

Up to frame size FSC, you can install reactors, filters and braking resistors as base components.

Permissible combinations:  Optional accessories (Page 82).

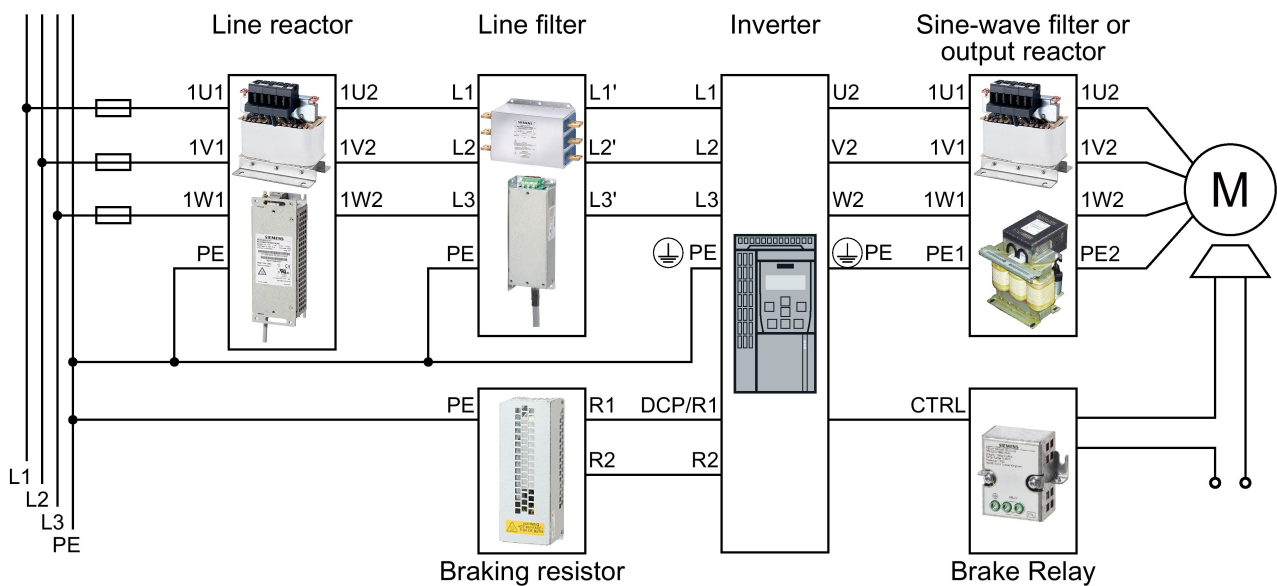

Figure 5-2 Connection overview FSA ... FSF

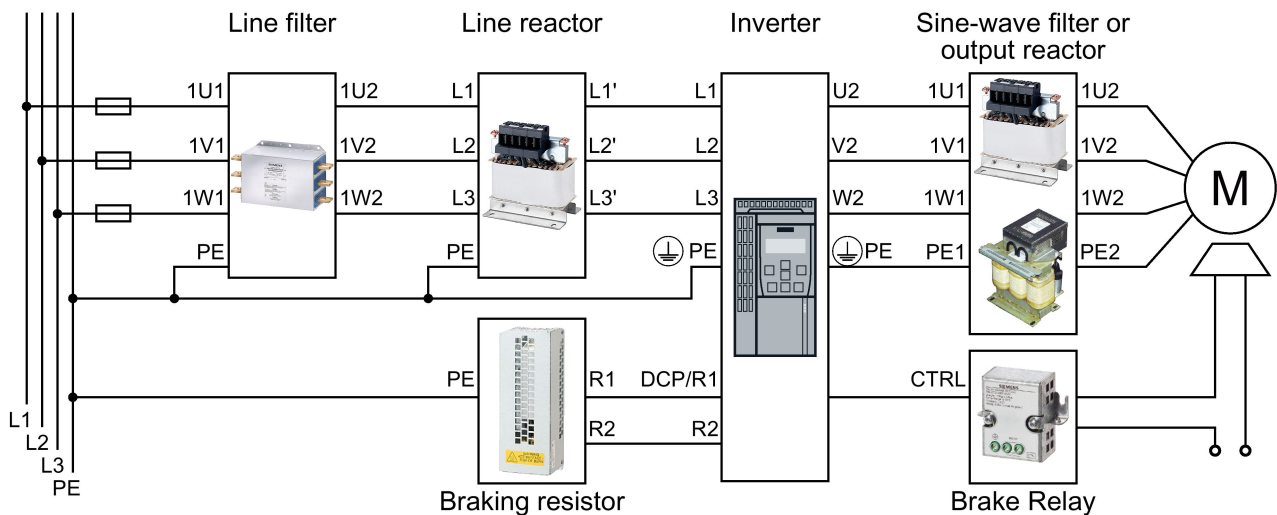
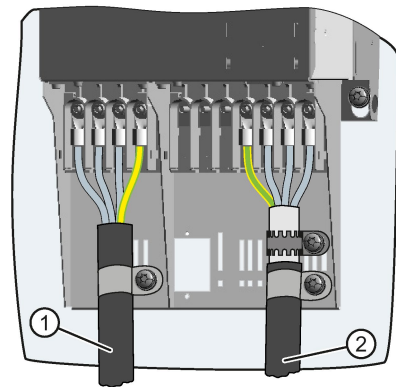

Figure 5-3 Connection overview FSGX

### 5.2.2 Connecting inverters in compliance with EMC regulations

EMC-compliant wiring for connecting the line supply and motor with shield plate.

- ① Line supply cable - unshielded
  - Strain relief using a cable clamp
- ② Motor cable - shielded
  - Shield connection using a toothed strip
  - Strain relief using a cable clamp



EMC-compliant wiring for connecting the line supply and motor without shield plate with a mounting panel with good conducting characteristics

- ① Line supply cable - unshielded
  - Strain relief using a cable clamp
- ② Motor cable - shielded
  - Shield connection using a cable clamp
  - Strain relief using a cable clamp

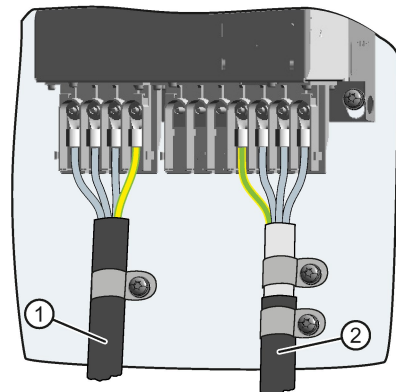

### 5.2.3 Length of motor cable

Always dimension the motor cable so that the ohmic losses are less than 5 % of the inverter power rating.

The permissible length of the motor cable also depends on the quality of the motor cable and the inverter pulse frequency. The values specified below are applicable for high quality cables, such as CY100 or similar, and for the pulse frequencies set in the factory.

 Pulse frequencies (Page 71).

If you set pulse frequencies other than the factory setting, then you must ensure that the EMC category is complied with on the plant or system side.

EMC-compliant wiring is required in order that the specified EMC category is attained.

 Electromagnetic compatibility of variable-speed drives (Page 74)

When using the inverter in the first environment, also carefully observe the information in Section

 Inverter applications (Page 76)

Table 5- 1 Permissible length of motor connecting cables

Frame size	Inverter with filter, category C2, internal or external <sup>1)</sup>			Inverter without filter					
	EMC category			No EMC category					
	First/second environment, C2	Second environment, C3	No EMC category	Without output reactor/ without sine-wave filter		With output reactor		With sine-wave filter	
	Shielded	Shielded	Shielded	Shielded	Unshielded	Shielded	Unshielded	Shielded	Unshielded
FSA	25 m	25 m	50 m	50 m	100 m	100 m	100 m	200 m	300 m
FSB	25 m	25 m	50 m	50 m	100 m	100 m	150 m	200 m	300 m
FSC	25 m	25 m	50 m	50 m	100 m	100 m	150 m	200 m	300 m
FSD	25 m	25 m	50 m	50 m	100 m	200 m	300 m	200 m	300 m
FSE	25 m	25 m	50 m	50 m	100 m	200 m	300 m	200 m	300 m
FSF	25 m	25 m	50 m	50 m	100 m	200 m	300 m	200 m	300 m
FSGX	25 m	25 m	200 m	200 m	300 m	300 m	450 m	300 m	450 m

<sup>1)</sup> External filter:  Line filter (Page 88)

### 5.2.4 Inverter terminals

Table 5- 2 Connection type, cable cross sections and tightening torques

Inverters	Connection		Cross-section and tightening torque		Strip lengths
			Metric	Imperial	
<b>FSA</b>	Line, motor cable, DC link and braking resistor	Terminal	1.0 ... 2.5 mm <sup>2</sup> 1.1 Nm	18 ... 14 AWG: 9.7 lbf in	8 mm
<b>FSB</b>	Line, motor cable, DC link and braking resistor	Terminal	1.5 ... 6 mm <sup>2</sup> 1.5 Nm	16 ... 10 AWG: 13 lbf in	8 mm
<b>FSC</b>	Line, motor cable, DC link and braking resistor	Terminal	4 ... 10 mm: 2.3 Nm	12 ... 8 AWG: 20 lbf in	10 mm
<b>FSD</b>	Line, motor cable, DC link and braking resistor	Cable lug	10 ... 35 mm <sup>2</sup> : 6 Nm	7 ... 2 AWG: 53 lbf in	--
<b>FSE</b>	Line, motor cable, DC link and braking resistor	Cable lug	25 ... 50 mm <sup>2</sup> : 6 Nm	3 ... 1 AWG: 53 lbf in	--
<b>FSF</b>	Line, motor cable, DC link and braking resistor	Cable lug	35 ... 120 mm <sup>2</sup> : 13 Nm	2 ... 4/0 AWG: 115 lbf in	--
<b>FSGX</b>	Line, motor cable, DC link and braking resistor	Cable lug	95 ... 2*240 mm <sup>2</sup> : 14 Nm	3/0 ... 2*600 AWG: 120 lbf in	--

The cross-section specifications refer to possible cable cross-sections for the terminals, not the current that you require for your particular application.

## 5.2.5 Establishing connections

### Procedure



Proceed as follows to establish the connections:

1. Ensure that the device is in a no-voltage condition and the DC link is discharged.
2. Establish the connections as described in the following sections.



This means that you have established the connections.

### 5.2.5.1 Connections FSA ... FSC

The terminals are directly accessible.

Connect the phases of the line cable to terminals L1, L2, L3 and the protective conductor to PE.

Connect the motor cable phases to terminals U2, V2, W2 and the protective conductor to .

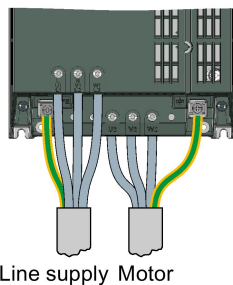

Line supply Motor

### 5.2.5.2 Connections FSD ... FSF

The terminals for the line and motor connection have covers to provide touch protection. You must make the terminals accessible in order to establish the connections

1. Ensure that the device is in a no-voltage condition and the DC link is discharged.
2. To connect up, release the catches on both sides of the terminal covers using a screwdriver
3. Lift up the covers as shown in the diagram.
4. Connect the line cable phases to L1, L2, L3 and the protective conductor to PE.
5. Connect the motor cable phases to U2, V2, W2 and the protective conductor to .
6. Close the covers once you have established the connections.

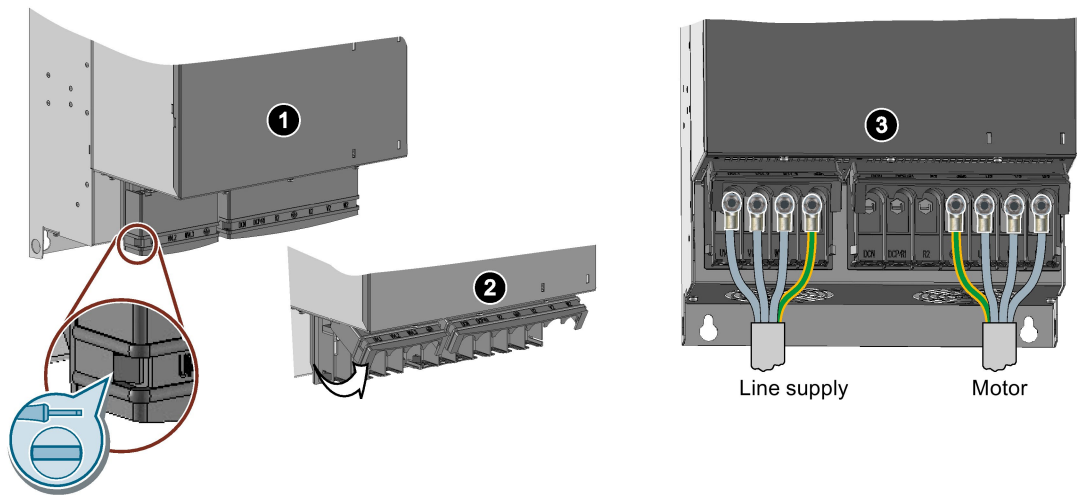

**Connection rules for Power Modules, FSD ... FSF**

Connect the line and motor cables to the inverter using ring-shaped cable lugs which are in conformance with DIN 462.

A suitable ring-shaped cable lug is shown at the left in the diagram, and an unsuitable standard cable lug is shown at the right.

The covers of the power connections must be closed in order that the IP20 degree of protection is maintained.



**5.2.5.3 Connections FSGX**

The connecting terminals have covers to prevent them from being touched. You must remove the front cover of the Power Module in order to establish the connections.

1. Loosen the two screws at the bottom of the front cover and push the door slightly upwards.
2. Remove the cover towards the front. The terminals are now accessible.
3. Connect the line supply through the upper cable glands at terminals U1, V1 and W1, the protective conductor at PE1. Use cable lugs according to DIN 462.
4. If you are using a braking resistor, connect the braking chopper through the lateral cable gland of the inverter at terminals DCPA and DCNA.
5. Connect the motor cable through the lower cable glands at terminals U2, V2, W2 and the protective conductor at PE2. Use cable lugs according to DIN 462.
6. Connect the external 24 V supply - and when necessary the line contactor control - through the lower cable glands at terminal block -X9. Maximum connection cross-section, 1.5 mm<sup>2</sup>

- Terminal 1: P24V
- Terminal 2: M
- Terminals 3 and 4: Reserved - do not use!
- Terminal 5: HS1
- Terminal 6: HS2

7. After you have established the connections, re-attach the inverter front cover.

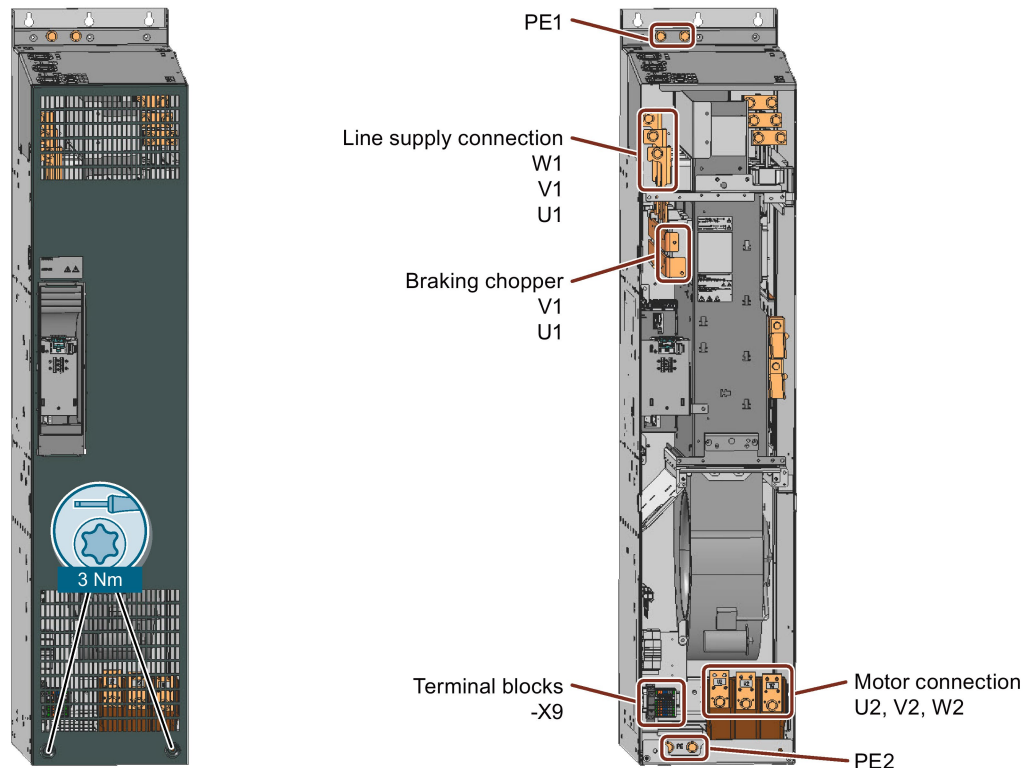

### External 24 V supply

An external power supply with the following specifications is required to operate the FSGX Power Module.

- 24 V DC (20.4 V - 28.8 V)
- Maximum current drain 4 A.

### Line contactor control

The Power Module closes the line contactor before the motor is switched on. The line contactor is opened after the motor has been switched off. If the motor is switched on, after a specific tolerance time, the Power Module monitors the line voltage.

The line contactor control via -X9 is optional. You can also externally control the line contactor.

### 5.3 Connecting the motor to the inverter in a star or delta connection

Standard induction motors with a rated power of approximately  $\leq 3$  kW are normally connected in a star/delta connection (Y/ $\Delta$ ) at 400 V/230 V. For a 400-V line supply, you can connect the motor to the inverter either in a star or in a delta connection.

#### Operating the motor in a star connection

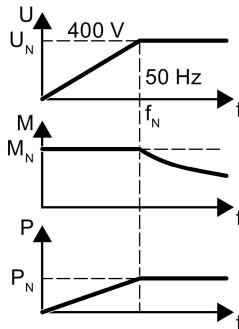
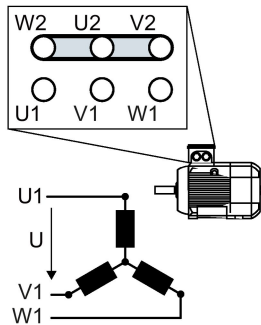

In a star connection, the motor can provide its rated torque  $M_N$  in the range 0 ... rated frequency  $f_N$ .

Rated voltage  $U_N = 400$  V is available at a rated frequency  $f_N = 50$  Hz.

The motor goes into field weakening above the rated frequency. In field weakening, the available motor torque decreases linearly with  $1/f$ . In field weakening, the available power remains constant.

#### Operating the motor in a delta connection with 87 Hz characteristic

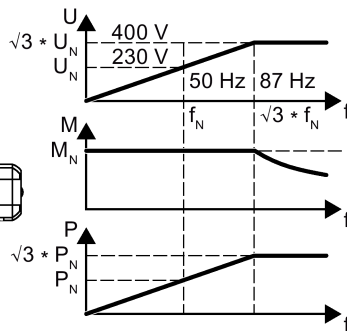
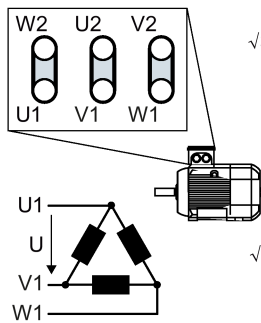

In a delta connection, the motor is operated with a voltage and frequency above its rated values. As a consequence, the motor power is increased by a factor  $\sqrt{3} \approx 1.73$ .

In the range  $f = 0 \dots 87$  Hz, the motor can output its rated torque  $M_N$ .

The maximum voltage  $U = 400$  V is available at a frequency of  $f = \sqrt{3} \times 50$  Hz  $\approx 87$  Hz.

The motor only goes into field weakening above 87 Hz.

The higher motor power when operated with an 87 Hz characteristic has the following disadvantages:

- The inverter must supply approximately 1.73x current. Select an inverter based on its rated current - and not its rated power.
- The motor temperature increases more significantly than when operated with  $f \leq 50$  Hz.
- The motor must have windings that are approved for a voltage  $>$  rated voltage  $U_N$ .
- As the fan impeller rotates faster, the motor has a higher noise level than operation with  $f \leq 50$  Hz.

 <b>WARNING</b>
<p><b>Risk of fire or electric shock as a result of defective components</b></p> <p>If an overcurrent protection device responds, this can indicate that a fault current was interrupted.</p> <p>Check the circuit components and all of the components of the inverter and replace defective parts and components to reduce the risk of a fire or an electric shock.</p> <p>You must replace the complete overload relay if the current carrying element of the relay has burnt through.</p>

## Repair

 <b>WARNING</b>
<p><b>Danger due to incorrect repair</b></p> <p>Repairs may only be carried out by Siemens Service, by repair centers authorized by Siemens or by authorized personnel who are thoroughly acquainted with all the warnings and operating procedures contained in this manual.</p> <ul style="list-style-type: none"><li>• Only use original spare parts when carrying out repairs.</li></ul>

## 6.1 Maintenance

The purpose of maintenance is to maintain the specified condition of the Power Module.

Regularly remove dirt and pollution, and replace the fan in plenty of time.  Replace the fan (Page 54)

### Cleaning

Clean the inverter with an anti-static brush, a vacuum cleaner and areas that are difficult to access, using dry compressed air (max. 1 bar).

### Ventilation

The devices must be installed in a cabinet. Ensure that the cabinet's ventilation slots are not blocked. Check that the fan is functioning correctly.

### Cables and screw terminals

Regularly check the cables for damage, and immediately replace any defective parts.

Regularly check that the screw terminals have been correctly tightened. Retighten the screws if necessary.

---

#### Note

The actual maintenance intervals depend on the installation and operating conditions.

Siemens offers its customers support in the form of service contracts. For further information, contact your Siemens regional office or sales office.

---

## 6.2 Commissioning after a long storage time

If the inverter was not operational for a longer period of time, it is possible that you must form the DC link capacitors before switching on.

Form the DC link capacitors in the following cases:

- If the inverter was not operational for longer than one year.
- If the date of manufacture of the inverter was more than one year ago when commissioning the drive system for the first time. The date of manufacture is coded in the serial number (see the next paragraph).

You form the DC link capacitors by connecting power to the inverters as shown below.

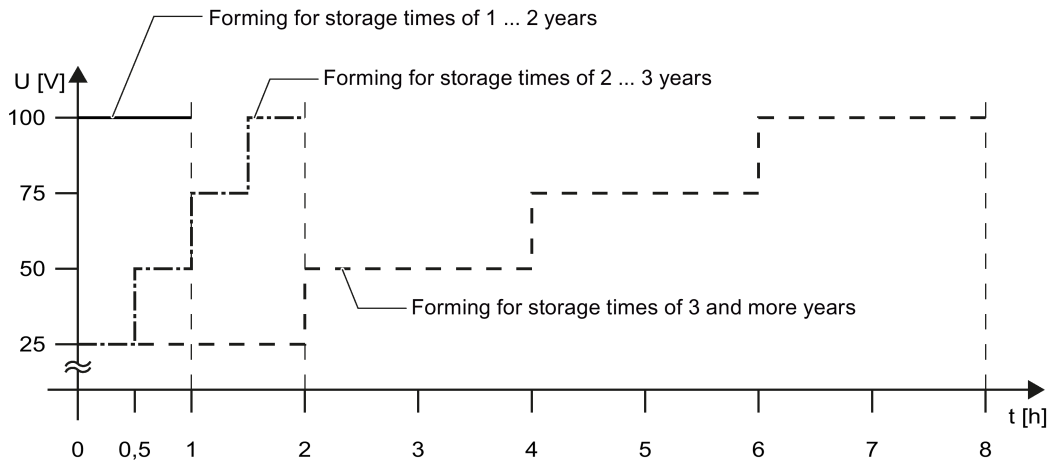

Figure 6-1 Forming the DC link capacitors

### Data of manufacture of the inverter

The date of manufacture of the inverter is encrypted in positions 3 - 6 of the serial number.

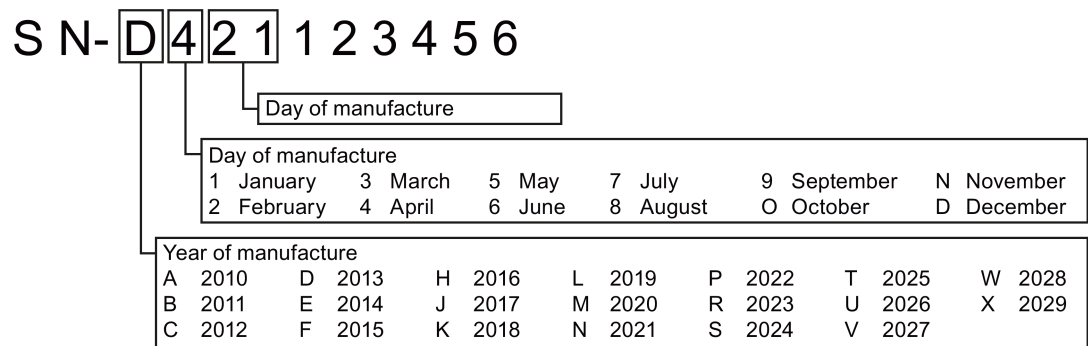

Figure 6-2 Data of manufacture in the serial number (example, April 21, 2013)

## 6.3 Replace the fan

### Service life of the fan

The average service life of the fan is 40,000 hours. In practice, however, the service life may deviate from this value. Especially a dusty environment can block up the fan.

The fan must be replaced in good time to ensure that the inverter is ready for operation.

### Fan replacement, frame size FSA

The fan is located in the lower section in the inverter heat sink.

#### Procedure

1. Switch the inverter off.
2. Remove the Control Unit from the inverter.
3. Disconnect all the cables from the Power Module.
4. Place the Power Module down on a clean and secure surface with the front side facing downwards.
5. Replace the fan as shown in the diagram.

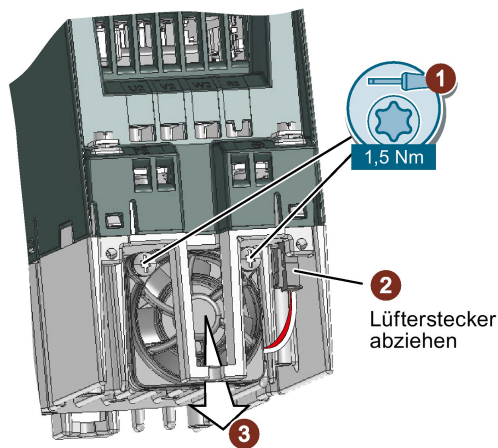

Install the new fan in the reverse sequence.

## Fan replacement, frame sizes FSB, FSC

### Procedure

1. Switch-off the inverter.
2. Remove the Control Unit from the inverter.
3. Disconnect all the cables from the Power Module.
4. Place the Power Module on a clean and secure surface with its front side down.
5. Replace the fan as described below
6. Release the two screws ①
7. Remove the fan from the device ②
8. Release the fan connector ③

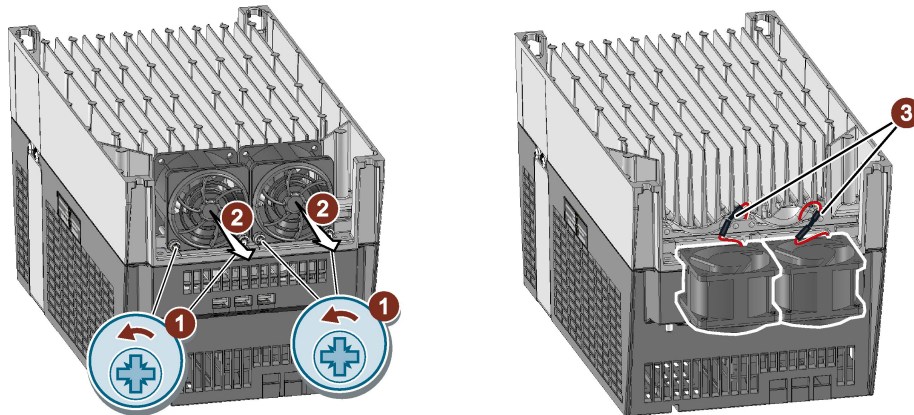

Install the new fan in the inverse sequence.

Fan replacement, frame sizes FSD and FSE:

Procedure

1. Switch the inverter off.
2. Disconnect all the cables from the Power Module.
3. Release the fan cover catches ①
4. Release and remove the fan cover ②, ③
5. Remove the fan connector ④
6. Release the fan catches ⑤
7. Remove the fan from the device ⑥

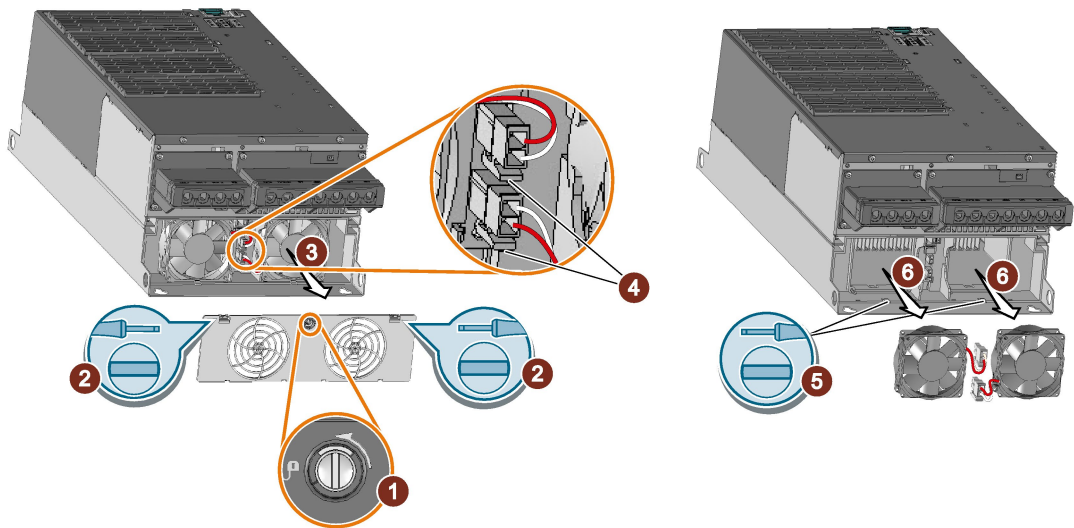

Install the new fan in the inverse sequence.

## Fan replacement, frame size FSF

### Procedure

1. Switch-off the inverter.
2. Disconnect all the cables from the Power Module.
3. Release the four screws and remove the fan cover plate ①, ②
4. Remove the fan connector ③
5. Release the screws of the fan mounting bracket ④
6. Remove the fan mounting bracket ⑤
7. Swivel the fan sideways towards the outside and then remove it from the inverter ⑥

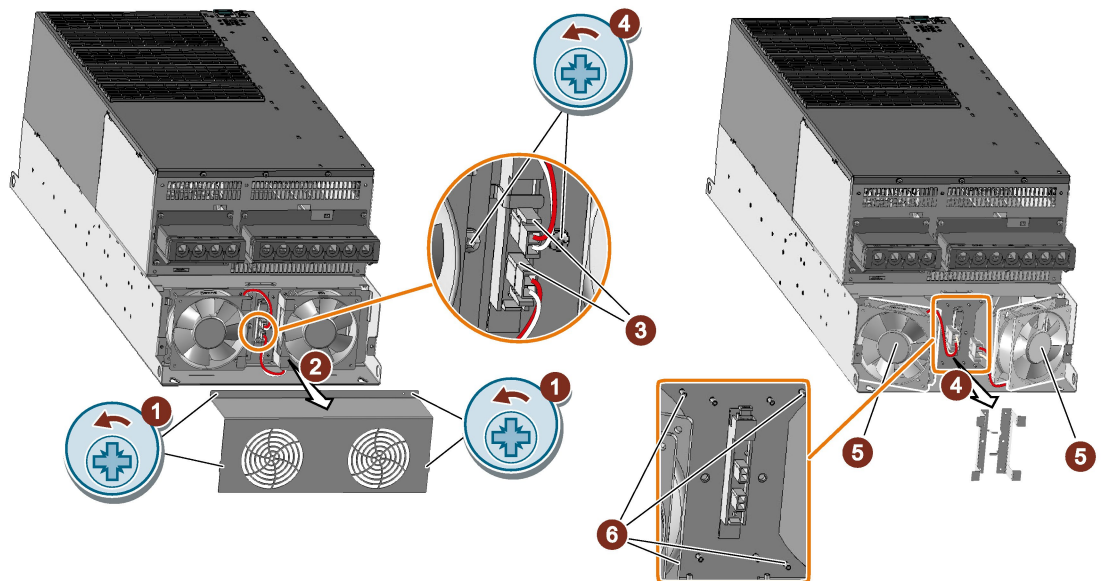

Install the new fan in the inverse sequence. You can additionally secure the fan using four M3 nuts on the guide bolts ⑥.

### Fan replacement, frame size FSGX

#### Procedure

1. Switch off the inverter.
2. Remove the inverter front cover.  Connections FSGX (Page 48).
3. Replace the fan as shown in the diagram.

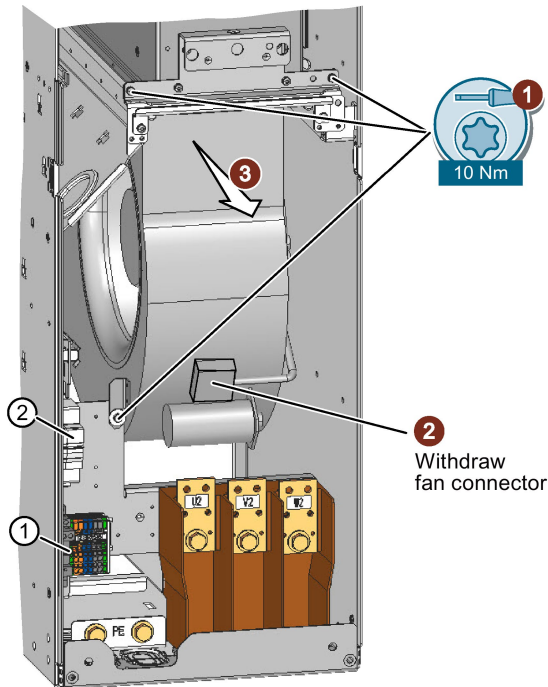

Install the new fan in the reverse sequence.

#### Fan relay and fan fuses

The fan is controlled using a relay in the inverter. It is located to the left next to terminal block -X9 (①). The fan fuses are located above terminal block -X9 (②).

## 6.4 Replacing the FSGX power block

### Replacing the power block, frame size FSGX

#### Procedure

1. Switch the inverter off.
2. Remove the inverter front cover.  Connections FSGX (Page 48).

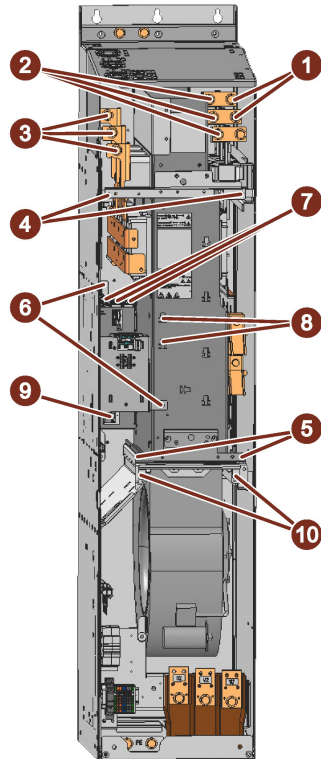

3. Release the connection to the motor output area (3 screws on the right-hand side). ①
4. Release the 3 screws on the left-hand side and swivel the connection bar upwards. ②
5. Release the connection at the line supply (3 screws). ③
6. Remove the mounting screws on the upper side (2 screws). ④
7. Remove the mounting screws on the lower side (2 screws). ④
8. Remove the electronics module. Where relevant, remove the communication connector and the terminal wiring. ⑥
9. Release the fiber-optic cable connectors (3 connectors) ⑦
10. Disconnect the cable connection for the signal cables (2 connectors). ⑧ Remove the IPD module by releasing the two knurled screws. The IPD module remains connected to the current sensor cables.
11. Withdraw the connector for the thermo element. ⑨

*6.4 Replacing the FSGX power block*

12. Release the two mounting screws for the fan and attach the tool to uninstall the Power Block at this location ⑩.
13. You can now slide out the Power Block from the inverter towards the front. To do this, use the crane lifting lugs at the Power Block. The Power Block busbars cannot be used as lifting lugs.

## Technical data

### Permissible power range of the motors

For the Power Modules, induction motors are permissible in the range from 25 % ... 150 % of the inverter power without any restrictions.

---

#### Note



#### Motors for inverter operation

Only use motors that are suitable for operation with inverters with a DC link.

---

## 7.1 Ambient conditions

Property	Version
<b>Ambient conditions for transport in the transport packaging</b>	
Climatic ambient conditions	- 40 °C ... + 70 °C, according to Class 2K4 to EN 60721-3-2 maximum humidity 95 % at 40 °C
Mechanical ambient conditions	FSA ... FSC: Shock and vibration permissible according to 1M2 to EN 60721-3-2 FSD ... FSF: Shock and vibration permissible according to 2M3 to EN 60721-3-2 FSGX: Shock and vibration permissible according to 2M2 to EN 60721-3-2
Protection against chemical substances	Protected according to Class 2C2 to EN 60721-3-2
Biological environmental conditions	Suitable according to Class 2B1 to EN 60721-3-2
<b>Ambient conditions for long-term storage in the product packaging</b>	
Climatic ambient conditions	- 25 °C ... + 55 °C, according to Class 1K3 to EN 60721-3-1
Protection against chemical substances	Protected according to Class 1C2 to EN 60721-3-1
Biological environmental conditions	Suitable according to Class 1B1 according to EN 60721-3-1

Property	Version
<b>Ambient conditions in operation</b>	
Installation altitude	Up to 1000 m above sea level without derating, > 1000 m  Restrictions for special ambient conditions (Page 72)
Climatic ambient conditions <sup>1)</sup>	<ul style="list-style-type: none"> <li>• Temperature range <sup>2)</sup> <ul style="list-style-type: none"> <li>– In operation, according to LO - 10 °C ... + 40 °C</li> <li>– In operation, according to HO - 10 °C ... + 50 °C</li> <li>– For higher temperatures  Restrictions for special ambient conditions (Page 72)</li> </ul> </li> <li>• Relative humidity: 5 ... 95%, condensation not permitted</li> <li>• Oil mist, salt mist, ice formation, condensation, dripping water, spraying water, splashing water and water jets are not permitted</li> </ul>
Mechanical ambient conditions	<ul style="list-style-type: none"> <li>• FSA ... FSF: Vibration levels permissible according to Class 3M1 to EN 60721-3-3</li> <li>• FSGX: Vibration test according to IEC 60068-2-6, 10 vibration cycles per axis                             <ul style="list-style-type: none"> <li>– in the range 10 Hz ... 58Hz with a deflection of 0.075 mm</li> <li>– in the range from 58 Hz ... 200 Hz with an acceleration of 1 g</li> </ul> </li> <li>• FSA ... FSC: Shock, permissible according to Class 3M2 to EN 60721-3-3</li> <li>• FSD ... FSF: Shock permissible according to Class 3M1 to EN 60721-3-3</li> <li>• FSGX: Shock test according to IEC 60068-2-27, three shocks (impacts) for each axis in both directions                             <ul style="list-style-type: none"> <li>– Peak acceleration: 5 g</li> <li>– Duration: 30 ms</li> </ul> </li> </ul>
Protection against chemical substances	Protected according to Class 3C2 according to EN 60721-3-3
Biological environmental conditions	Suitable for Class 3B1 according to EN 60721-3-3
Pollution	Suitable for environments with degree of pollution 2 according to EN 61800-5-1
Cooling	IP20 inverter: Forced air cooling AF, according to EN 60146
Cooling air	clean and dry air

<sup>1)</sup> Increased ruggedness regarding temperature range and relative humidity; therefore better than Class 3K3 to EN 60721-3-3

<sup>2)</sup> Observe the permissible ambient temperatures for the Control Unit and possibly the operator panel (IOP or BOP-2).

**Approvals**

UL, cUL, CE, C-tick, SEMI F47.

Use UL-certified fuses in order to comply with UL requirements.

## 7.2 Overload capability of the inverter

Overload capability is the property of the inverter to temporarily supply a current that is higher than the rated current to accelerate a load. Two typical load cycles are defined to clearly demonstrate the overload capability: "Low Overload" and "High Overload"

### Definitions

#### Base load

Constant load between the accelerating phases of the drive

#### Low Overload

- **LO base load input current**  
Permissible input current for a "Low Overload" load cycle
- **LO base load output current**  
Permissible output current for a "Low Overload" load cycle
- **LO base load power**  
Rated power based on the LO base load output current

#### High Overload

- **HO base load input current**  
Permissible input current for a "High Overload" load cycle
- **HO base load output current**  
Permissible output current for a "High Overload" load cycle
- **HO base load power**  
Rated power based on the HO base load output current

If not specified otherwise, the power and current data in the technical data always refer to a load cycle according to Low Overload.

We recommend the "SIZER" engineering software to select the inverter.



You will find additional information about SIZER on the Internet: Download SIZER (<http://support.automation.siemens.com/WW/view/en/10804987/130000>).

**Load cycles and typical applications:**

**"Low Overload" load cycle**

The "Low Overload" load cycle assumes a uniform base load with low requirements placed on brief accelerating phases. Typical applications when designing according to "Low Overload" include:

- Pumps, fans and compressors
- Wet or dry blasting technology
- Mills, mixers, kneaders, crushers, agitators
- Basic spindles
- Rotary kilns
- Extruders

**"High Overload" load cycle**

The "High Overload" load cycle permits, for reduced base load, dynamic accelerating phases. Typical applications when designing according to "High Overload" include:

- Horizontal and vertical conveyor technology (conveyor belts, roller conveyors, chain conveyors)
- Centrifuges
- Escalators/moving stairways
- Lifters/Lowerers
- Elevators
- Gantry cranes
- Cable railways
- Storage and retrieval machines

**Typical inverter load cycles**

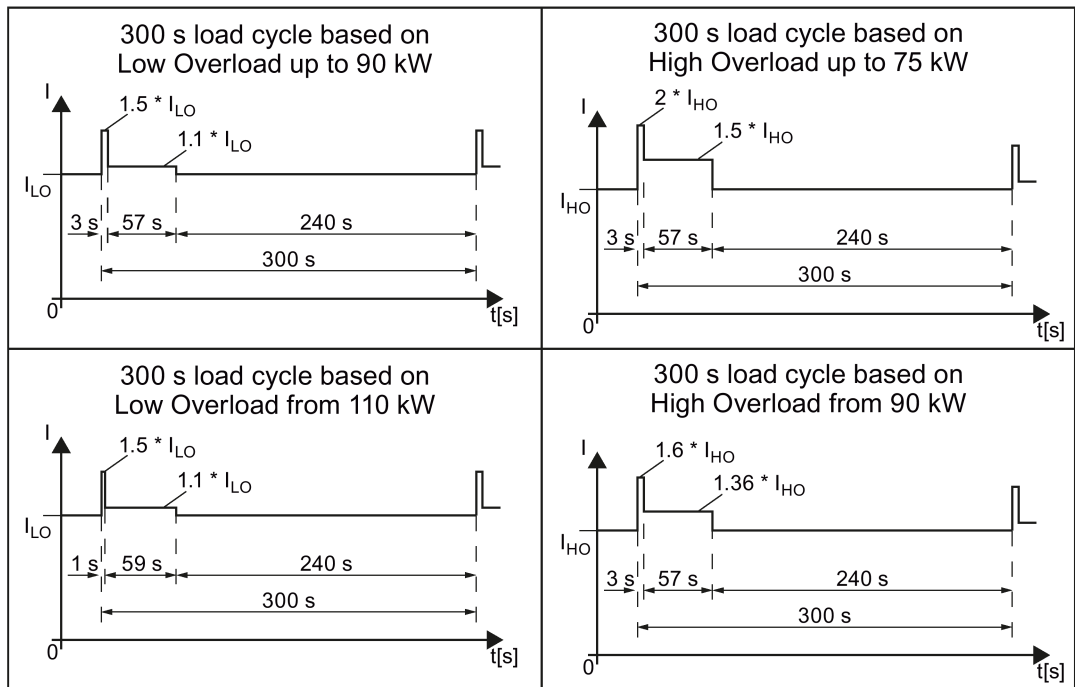

Figure 7-1 "High Overload" and "Low Overload" load cycles

## 7.3 Cable cross-sections and tightening torques

Table 7- 1 Connection type, cable cross sections and tightening torques

Inverters	Connection		Cross-section and tightening torque		Strip lengths
			Metric	Imperial	
<b>FSA</b>	Line, motor cable, DC link and braking resistor	Terminal	1.0 ... 2.5 mm <sup>2</sup> 1.1 Nm	18 ... 14 AWG: 9.7 lbf in	8 mm
<b>FSB</b>	Line, motor cable, DC link and braking resistor	Terminal	1.5 ... 6 mm <sup>2</sup> 1.5 Nm	16 ... 10 AWG: 13 lbf in	8 mm
<b>FSC</b>	Line, motor cable, DC link and braking resistor	Terminal	4 ...10 mm: 2.3 Nm	12 ... 8 AWG: 20 lbf in	10 mm
<b>FSD</b>	Line, motor cable, DC link and braking resistor	Cable lug	10 ... 35 mm <sup>2</sup> : 6 Nm	7 ... 2 AWG: 53 lbf in	--
<b>FSE</b>	Line, motor cable, DC link and braking resistor	Cable lug	25 ... 50 mm <sup>2</sup> : 6 Nm	3 ... 1 AWG: 53 lbf in	--
<b>FSF</b>	Line, motor cable, DC link and braking resistor	Cable lug	35 ... 120 mm <sup>2</sup> : 13 Nm	2 ... 4/0 AWG: 115 lbf in	--
<b>FSGX</b>	Line, motor cable, DC link and braking resistor	Cable lug	95 ... 2*240 mm <sup>2</sup> : 14 Nm	3/0 ... 2*600 AWG: 120 lbf in	--

The cross-section specifications refer to possible cable cross-sections for the terminals, not the current that you require for your particular application.

## 7.4 General data

Property	Version
Line voltage	3-phase 380 ... 480 VAC $\pm$ 10%
Output voltage	3-phase 0 VAC ... input voltage x 0.95 (max.)
Input frequency	50 Hz ... 60 Hz, $\pm$ 3 Hz
Output frequency	0 Hz ... 550 Hz, depending on the control mode
Power factor $\lambda$	0.7 ... 0.85
Inrush current	< LO base load input current
Overvoltage category according to EN 60664-1	The inverter insulation is designed for surge voltages according to overvoltage Category III.
Short-circuit current rating (SCCR)	$\leq$ 65 kA rms for FSA ... FSGX with fuses, Class J $\leq$ 5 kA rms for FSA ... FSC with semiconductor fuses $\leq$ 65 kA rms for FSD ... FSGX with semiconductor fuses
Pulse frequency (factory setting)	<ul style="list-style-type: none"> <li>• 4 kHz for devices with an LO base load power <math>\leq</math> 90 kW</li> <li>• 2 kHz for devices with an LO base load power &gt; 90 kW</li> </ul> Can be set in 2 kHz steps in the range 2 kHz ... 16 kHz. If you increase the pulse frequency, the inverter reduces the maximum output current.  Current derating depending on the pulse frequency (Page 71)
Electromagnetic compatibility	The devices are suitable for environments of categories C1 and C2 according to IEC/EN 61800-3.
Braking methods	DC braking, compound braking, dynamic braking with integrated braking chopper
Degree of protection according to EN 60529	IP20      Installation in a control cabinet required

## 7.5 Specific technical data

The given input currents are valid for operation without a line reactor for a line voltage of 400 V with  $V_k = 1\%$  referred to the rated power of the inverter. If you use a line reactor, then the current is reduced by several percentage points.

### Note

#### When do you require a line reactor?

Without line reactor, the inverter is suitable for line supplies with  $U_k \geq 1\%$ . For  $U_k < 1\%$ , you must use a line reactor.

### Note

The values for High Overload (HO) are identical with the rated inverter values

Table 7- 2 PM240, IP20, frame sizes A, 3-phase 380 ... 480 VAC

Article no. - without filter	6SL3224-...	...0BE13-7UA0	...0BE15-5UA0	...0BE17-5UA0
LO base load power		0.37 kW	0.55 kW	0.75 kW
LO base load input current		1.6 A	2.0 A	2.5 A
LO base load output current		1.3 A	1.7 A	2.2 A
HO base load power		0.37 kW	0.55 kW	0.75 kW
HO base load input current		1.6 A	2.0 A	2.5 A
HO base load output current		1.3 A	1.7 A	2.2 A
Fuse according to UL (from SIEMENS)		3NE1813-0, 16 A	3NE1813-0, 16 A	3NE1813-0, 16 A
Fuse according to UL (Class J, K-1 or K-5)		10 A	10 A	10 A
Power loss		0.097 kW	0.099 kW	0.102 kW
Required cooling air flow		4.8 l/s	4.8 l/s	4.8 l/s
Weight		1.2 kg	1.2 kg	1.2 kg

Table 7- 3 PM240, IP20, frame sizes A, 3-phase 380 ... 480 VAC

Article no. - without filter	6SL3224-...	...0BE21-1UA0	...0BE21-5UA0
LO base load power		1.1 kW	1.5 kW
LO base load input current		3.9 A	4.9 A
LO base load output current		3.1 A	4.1 A
HO base load power		1.1 kW	1.5 kW
HO base load input current		3.8 A	4.8 A
HO base load output current		3.1 A	4.1 A
Fuse according to UL (from SIEMENS)		3NE1813-0, 16 A	3NE1813-0, 16 A
Fuse according to UL (Class J, K-1 or K-5)		10 A	10 A
Power loss		0.108 kW	0.114 kW
Required cooling air flow		4.8 l/s	4.8 l/s
Weight		1.1 kg	1.1 kg

Table 7- 4 PM240, IP20, frame sizes B, 3-phase 380 ... 480 VAC

Article no. - without filter	6SL3224-...	...0BE22-2UA0	...0BE23-0UA0	...0BE24-0UA0
Article no. - with filter	6SL3224-...	...0BE22-2AA0	...0BE23-0AA0	...0BE24-0AA0
LO base load power		2.2 kW	3 kW	4 kW
LO base load input current		7.6 A	10.2 A	13.4 A
LO base load output current		5.9 A	7.7 A	10.2 A
HO base load power		2.2 kW	3 kW	4 kW
HO base load input current		7.6 A	10.2 A	13.4 A
HO base load output current		5.9 A	7.7 A	10.2 A
Fuse according to UL (from SIEMENS)		3NE1813-0, 16 A	3NE1813-0, 16 A	3NE1814-0, 20 A
Fuse according to UL (Class J, K-1 or K-5)		16 A	16 A	20 A
Power loss		0.139 kW	0.158 kW	0.183 kW
Required cooling air flow		24 l/s	24 l/s	24 l/s
Weight		4.3 kg	4.3 kg	4.3 kg

7.5 Specific technical data

Table 7- 5 PM240, IP20, frame sizes C, 3-phase 380 ... 480 VAC

<b>Article no. - without filter</b>	<b>6SL3224-...</b>	<b>...0BE25-5UA0</b>	<b>...0BE27-5UA0</b>	<b>...0BE31-1UA0</b>
<b>Article no. - with filter</b>	<b>6SL3224-...</b>	<b>...0BE25-5AA0</b>	<b>...0BE27-5AA0</b>	<b>...0BE31-1AA0</b>
LO base load power		7.5 kW	11 kW	15 kW
LO base load input current		21.9 A	31.5 A	39.4 A
LO base load output current		18 A	25 A	32 A
HO base load power		5.5 kW	7.5 kW	11 kW
HO base load input current		16.7 A	23.7 A	32.7 A
HO base load output current		13.2 A	19 A	26 A
Fuse according to UL (from SIEMENS)		3NE1814-0, 20 A	3NE1814-0, 20 A	3NE1803-0, 35 A
Fuse according to UL (Class J, K-1 or K-5)		20 A	20 A	35 A
Power loss		0.240 kW	0.297 kW	0.396 kW
Required cooling air flow		55 l/s	55 l/s	55 l/s
Weight without filter		6.5 kg	6.5 kg	6.5 kg
Weight with filter		7 kg	7 kg	7 kg

Table 7- 6 PM240, IP20, frame sizes D, 3-phase 380 ... 480 VAC

<b>Article no. - without filter</b>	<b>6SL3224-...</b>	<b>...0BE31-5UA0</b>	<b>...0BE31-8UA0</b>	<b>...0BE32-2UA0</b>
<b>Article no. - with filter</b>	<b>6SL3224-...</b>	<b>...0BE31-5AA0</b>	<b>...0BE31-8AA0</b>	<b>...0BE32-2AA0</b>
LO base load power		18.5 kW	22 kW	30 kW
LO base load input current		46 A	53 A	72 A
LO base load output current		38 A	45 A	60 A
HO base load power		15 kW	18.5 kW	22 kW
HO base load input current		40 A	46 A	56 A
HO base load output current		32 A	38 A	45 A
Fuse according to UL (SIEMENS)		3NE1817-0	3NE1818-0	3NE1820-0
Fuse according to UL (Class J)		50 A / 600 V	60 A / 600 V	80 A / 600 V
Power losses without filter		0.42 kW	0.55 kW	0.72 kW
Power losses with filter		0.44 kW	0.52 kW	0.69 kW
Required cooling air flow		22 l/s	22 l/s	39 l/s
Weight without filter		13 kg	13 kg	13 kg
Weight with filter		16 kg	16 kg	16 kg

Table 7- 7 PM240, IP20, frame sizes E, 3-phase 380 ... 480 VAC

<b>Article no. - without filter</b>	<b>6SL3224-...</b>	<b>...0BE33-0UA0</b>	<b>...0BE33-7UA0</b>
<b>Article no. - with filter</b>	<b>6SL3224-...</b>	<b>...0BE33-0AA0</b>	<b>...0BE33-7AA0</b>
LO base load power		37 kW	45 kW
LO base load input current		88 A	105 A
LO base load output current		75 A	90 A
HO base load power		30 kW	37 kW
HO base load input current		73 A	90 A
HO base load output current		60 A	75 A
Fuse according to UL (SIEMENS)		3NE1021-0	3NE1022-0
Fuse according to UL (Class J)		100 A / 600 V	125 A / 600 V
Power losses without filter		0.99 kW	1.2 kW
Power losses with filter		1.04 kW	1.2 kW
Required cooling air flow		22 l/s	39 l/s
Weight without filter		16 kg	16 kg
Weight with filter		23 kg	23 kg

Table 7- 8 PM240, IP20, frame sizes F, 3-phase 380 ... 480 VAC

<b>Article no. - without filter</b>	<b>6SL3224-...</b>	<b>...0BE34-5UA0</b>	<b>...0BE35-5UA0</b>	<b>...0BE37-5UA0</b>
<b>Article no. - with filter</b>	<b>6SL3224-...</b>	<b>...0BE34-5AA0</b>	<b>...0BE35-5AA0</b>	<b>...0BE37-5AA0</b>
LO base load power		55 kW	75 kW	90 kW
LO base load input current		129 A	168 A	204 A
LO base load output current		110 A A	145 A	178 A
HO base load power		45 kW	55 kW	75 kW
HO base load input current		108 A	132 A	169 A
HO base load output current		90 A	110 A	145 A
Fuse according to UL (SIEMENS)		3NE1224-0	3NE1225-0	3NE1227-0
Fuse according to UL (Class J)		150 A, 600 V	200 A, 600 V	250 A, 600 V
Power losses without filter		1.4 kW	1.9 kW	2.3 kW
Power losses with filter		1.5 kW	2.0 kW	2.4 kW
Required cooling air flow		94 l/s	94 l/s	117 l/s
Weight without filter		36 kg	36 kg	36 kg
Weight with filter		52 kg	52 kg	52 kg

7.5 Specific technical data

Table 7- 9 PM240, IP20, frame sizes F, 3-phase 380 ... 480 VAC

Article no. - without filter	6SL3224-...	...0BE38-8UA0	...0BE41-1UA0
LO base load power		110 kW	132 kW
LO base load input current		234 A	284 A
LO base load output current		205 A	250 A
HO base load power		90 kW	110 kW
HO base load input current		205 A	235 A
HO base load output current		178 A	205 A
Fuse according to UL (SIEMENS)		3NE1227-0	3NE1230-0
Fuse according to UL (Class J)		300 A, 600 V	400 A, 600 V
Power loss		2.4 kW	2.5 kW
Required cooling air flow		117 l/s	117 l/s
Cross section of line and motor cables		95 ... 120 mm <sup>2</sup> 3/0 ... 4/0 AWG	95 ... 120 mm <sup>2</sup> 3/0 ... 4/0 AWG
Tightening torque for line and motor cables		13 Nm / 115 lbf in	13 Nm / 115 lbf in
Weight		39 kg	39 kg

Table 7- 10 PM240 frame sizes GX, 3-phase 380 ... 480 VAC

Article no. - without filter	6SL3224-...	...0XE41-3UA0	...0XE41-6UA0	...0XE42-0UA0
LO base load power		160 kW	200 kW	240 kW
LO base load input current		297 A	354 A	442 A
LO base load output current		302 A	370 A	477 A
HO base load power		132 kW	160 kW	200 kW
HO base load input current		245 A	297 A	354 A
HO base load output current		250 A	302 A	370 A
Fuse according to UL (SIEMENS)		3NE1333-2	3NE1333-2	3NE1436-2
Fuse according to UL (Class J)		450 A / 600 V	500 A / 600 V	600 A / 600 V
Power loss,		3.9 kW	4.4 kW	5.5 kW
Required cooling air flow		360 l/s	360 l/s	360 l/s
Weight		176 kg	176 kg	176 kg

### 7.5.1 Current derating depending on the pulse frequency

MLFB	LO base load	Output base-load current for a pulse frequency of							
		2 kHz	4 kHz	6 kHz	8 kHz	10 kHz	12 kHz	14 kHz	16 kHz
6SL3224-...	kW	A	A	A	A	A	A	A	A
...0BE13-7UA0	0.37	--	<b>1.30</b>	1.11	0.91	0.78	0.65	0.59	0.52
...0BE15-5UA0	0.55	--	<b>1.70</b>	1.45	1.19	1.02	0.85	0.77	0.68
...0BE17-5UA0	0.75	--	<b>2.20</b>	1.87	1.54	1.32	1.10	0.99	0.88
...0BE21-1UA0	1.1	--	<b>3.10</b>	2.64	2.17	1.86	1.55	1.40	1.24
...0BE21-5UA0	1.5	--	<b>4.10</b>	3.49	2.87	2.46	2.05	1.85	1.64
...0BE22-2 . A0	2.2	--	<b>5.90</b>	5.02	4.13	3.54	2.95	2.66	2.36
...0BE23-0 . A0	3.0	--	<b>7.70</b>	6.55	5.39	4.62	3.85	3.47	3.08
...0BE24-0 . A0	4.0	--	<b>10.20</b>	8.67	7.14	6.12	5.10	4.59	4.08
...0BE25-5 . A0	7.5	--	<b>18.00</b>	16.20	13.30	11.40	9.50	8.60	7.60
...0BE27-5 . A0	11.0	--	<b>25.00</b>	22.10	18.20	15.60	13.00	11.70	10.40
...0BE31-1 . A0	15.0	--	<b>32.00</b>	27.20	22.40	19.20	16.00	14.40	12.80
...0BE31-5 . A0	18.5	--	<b>38.00</b>	32.30	26.60	22.80	19.00	17.10	15.20
...0BE31-8 . A0	22	--	<b>45.00</b>	38.25	31.50	27.00	22.50	20.25	18.00
...0BE32-2 . A0	30	--	<b>60.00</b>	52.70	43.40	37.20	31.00	27.90	24.80
...0BE33-0 . A0	37	--	<b>75.00</b>	63.75	52.50	45.00	37.50	33.75	30.00
...0BE33-7 . A0	45	--	<b>90.00</b>	76.50	63.00	54.00	45.00	40.50	36.00
...0BE34-5 . A0	55	--	<b>110.0</b>	93.50	77.00	--	--	--	--
...0BE35-5 . A0	75	--	<b>145.0</b>	123.3	101.5	--	--	--	--
...0BE37-5 . A0	90	--	<b>178.0</b>	151.3	124.6	--	--	--	--
...0BE38-8UA0	110	<b>205.0</b>	178.0	--	--	--	--	--	--
...0BE41-1UA0	132	<b>250.0</b>	205.0	--	--	--	--	--	--
...0XE41-3UA0	160	<b>302.0</b>	250.0	--	--	--	--	--	--
...0XE41-6UA0	200	<b>370.0</b>	302.0	--	--	--	--	--	--
...0XE42-0UA0	250	<b>477.0</b>	370.0	--	--	--	--	--	--

The permissible motor cable length depends on the particular cable type and the pulse frequency that has been selected

## 7.6 Restrictions for special ambient conditions

### Maximum current at low speeds

**NOTICE**

**Negative impact on the inverter service life.**

At low speeds, the inverter can only briefly supply the base load output current.

It is especially important to note that DC voltage operation (continuous operation at 0 Hz) is not permissible.

Refer to the following diagram for the operating conditions that are possible without having a negative impact on the inverter service life.

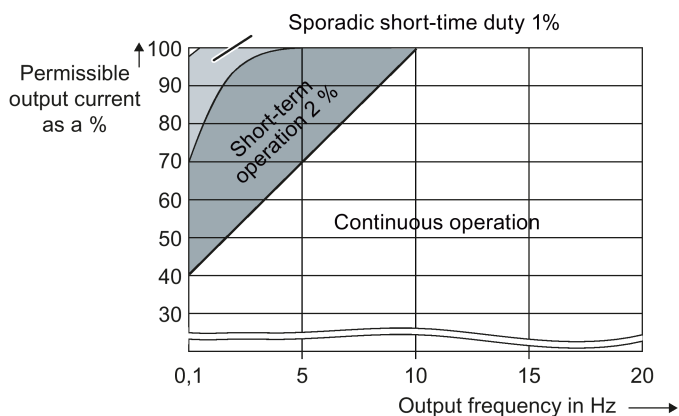

- |                          |  |
|--------------------------|--|
| Continuous operation:    | Operating state that is permissible for the complete operating time.         |
| Short-time duty          | Operating state that is permissible for less than 2 % of the operating time. |
| Sporadic short-time duty | Operating state that is permissible for less than 1 % of the operating time. |

### Current de-rating depending on the ambient operating temperature

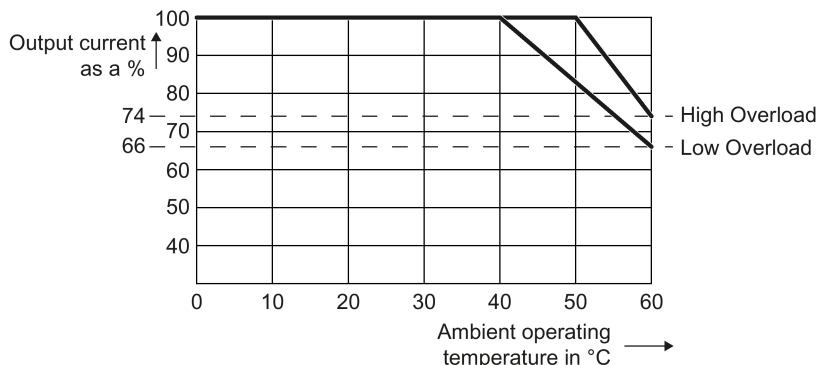

The Control Unit and operator panel can restrict the maximum permissible operating ambient temperature of the Power Module.

### Current derating or temperature reduction depending on the installation altitude

Above 1000 m above sea level you must reduce the inverter output current or the permissible operating ambient temperature as a result of the lower cooling capability of the air. Refer to the following diagrams for the values.

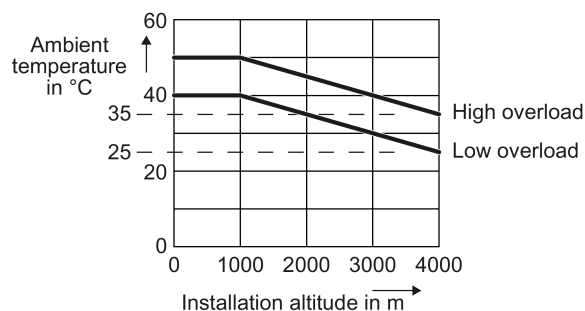
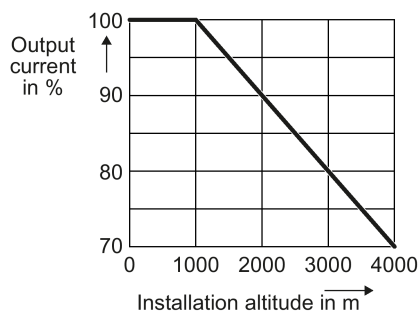

### Permissible line supplies depending on the installation altitude

- Installation altitude up to 2000 m above sea level
  - Connection to every supply system permitted for the inverter.
- Installation altitudes between 2000 m and 4000 m above sea level
  - Connection to a TN system with grounded neutral point.
  - TN systems with grounded line conductor are not permitted.
  - The TN line system with grounded neutral point can also be supplied using an isolation transformer.
  - The phase-to-phase voltage does not have to be reduced.

## 7.7 Electromagnetic compatibility of variable-speed drives

EMC (electromagnetic compatibility) means that the devices function satisfactorily without interfering with other devices and without being disrupted by other devices. This is true when the emitted interference (emission level) and the interference immunity are matched with each other.

The product standard IEC/EN 61800-3 describes the EMC requirements placed on "Variable-speed drive systems".

A variable-speed drive system (or Power Drive System PDS) consists of the inverter as well as the associated electric motors and encoders including the connecting cables.

The inverter comprises the Control Unit and Power Module.

The driven machine is not part of the drive system.

---

### Note

#### PDS as component of machines or systems

When you integrate PDS into machines or systems, additional measures may be required so that the product standards of these machines or systems is complied with. The machine or system builder is responsible for taking these measures.

---

## Environments and categories

### Environments

IEC/EN 61800-3 makes a distinction between the first and second environments - and defines different requirements for these environments.

- **First environment:**  
Residential buildings or locations at which the drive system is directly connected to a public low-voltage supply without intermediate transformer.
- **Second environment:**  
All locations that are connected to the public grid through their own, dedicated transformer. These are essentially industrial environments.

### Categories

IEC/EN 61800-3 makes a distinction between four drive system categories:

- **Category C1:**  
Drive systems for rated voltages < 1000 V for unrestricted use in the first environment
- **Category C2:**  
Stationary drive systems for rated voltages < 1000 V for operation in the second environment.  
  
The drive system must be installed by appropriately qualified and trained personnel.  
  
Additional measures are required for operation in the first environment,  
 Operation in the first environment (Page 78).
- **Category C3:**  
Drive systems for rated voltages < 1000 V - only for operation in the second environment.
- **Category C4:**  
Drive systems for IT line supplies for operation in complex systems in the second environment.  
  
An EMC plan must be created.

---

### Note

#### Appropriately trained and qualified personnel

An appropriately trained and qualified person has the necessary experience for installing and/or commissioning drive systems (Power Drive Systems - PDS), including the associated EMC aspects.

---

## 7.7.1 Inverter applications

Inverters involve equipment used on a professional basis, deployed in certain areas of business and industry - and are not operated in the general public domain.



Carefully observe the information in the "EMC installation guideline" Configuration Manual under EMC installation guideline (<http://support.automation.siemens.com/WW/view/en/60612658>) for EMC-compliant installation.

The Power Modules described here are intended for operation in the first and second environments. Conditions for operation in the respective environment are subsequently listed.

### 7.7.1.1 Operation in the second environment

#### Interference immunity

You do not have to take any additional measures regarding interference immunity.

#### Interference emission - operation in the second environment, Category C2

The drive system must comply with the following conditions in order to comply with the limit values of the second environment, Category C2:

- The drive system is installed by appropriately qualified personnel in compliance with EMC regulations - and the installation notes provided in the manual.
- You use a shielded motor cable with low capacitance.
- The pulse frequency is not higher than the value set in the factory.
- The drive system is connected to a TN or TT line supply.
- You comply with the permissible motor cable length.
  -  Length of motor cable (Page 44)
- The inverters are equipped with a Category C2 line filter (internal or external).
  - **Frame size FSA:**  
The inverters require an external footprint filter (base component), Category C2 (6SE6400-2FA00-6AD0)
  - **Frame size FSB-FSE:**  
The inverters with integrated filter are suitable for operation in the second environment, Category C2.
  - **Frame size FSF:**  
Inverters with integrated filter (55 kW, 75 kW, 90 kW) are suitable for operation in the second environment, Category C2.  
Inverters without integrated filter (110 kW, 132 kW) require an external filter, Category C2 (6SL3203-0BE32-5AA0).
  - **Frame size FSGX:**  
The inverters require an external filter, Category C2 (6SL3000-0BE36-0AA0)

With the external filters, from Section  Line filter (Page 88), the inverters without integrated filter comply with the requirements of the second environment, Category C2 with reference to interference emission.

If you use inverters without integrated filter or a filter other than those mentioned above, then you are responsible for verifying that the interference emission is limited.

You can use a dedicated radio interference suppression filter for each inverter - or a common filter for several inverters.

### Interference emission - operation in the second environment, Category C4

When connected to IT line supplies, only filtered inverters are permissible. Use external filters without capacitors with respect to ground to limit symmetrical interference emission.

When necessary, contact one of our Solution Partners

(<https://www.automation.siemens.com/solutionpartner/partnerfinder/Home/Index?country=DE&program=1&technology=19&lang=en>).

### 7.7.1.2 Operation in the first environment

#### Interference immunity

You do not have to take any additional measures regarding interference immunity.

#### Interference emission - operation in the first environment, Category C2

In order that you may operate the drive system in the first environment, Category C2, then in addition to the requirements for use in the second environment, you must also observe the limit values related to harmonic currents.

---

#### Note

##### Maintaining the limit values for harmonic currents

With respect to the compliance with limits for harmonic currents, the EMC product standard EN61800-3 for PDS refers to compliance with standards EN 61000-3-2 and EN 61000-3-12.

---

- **Inverters with an LO base load input current  $\leq 16$  A:**

These devices are not subject to any limit values, and as a consequence can be connected to the public low-voltage grid without any prior consultation.

- **Inverters with an LO base load input current  $> 16$  A and  $\leq 75$  A**

The drive system is in compliance with IEC/EN 61000-3-12 under the following precondition:

- FSC Power Modules: You use a line reactor.

---

#### Note

##### Line reactor

Contact one of our Solution Partners for a line reactor.



Solution Partners

(<https://www.automation.siemens.com/solutionpartner/partnerfinder/Home/Index?country=DE&program=1&technology=19&lang=en>).

---

FSD Power Modules: A line reactor is not required.

- Short-circuit power  $S_{SC}$  at the connection point of the customer's system to the public grid, is not greater or is equal to the value according to the following formula:

$$S_{SC} \geq 120 \cdot \sqrt{3} \cdot U_{in} \cdot \text{LO base load input current}$$

The installation company or company operating the drive system is responsible for ensuring that this device is only connected at a connection point with an appropriate short-circuit power (fault level).

**Example:** FSD inverter, 400 V, input current, 72 A:

$$S_{SC} \geq 120 \cdot \sqrt{3} \cdot 400 \text{ V} \cdot 72 \text{ A}$$

This corresponds to a low-voltage transformer with an apparent power rating of approximately 300 kVA ... 400 kVA with 4 % ... 6 %  $U_k$

If these preconditions do not apply, then the installation company or company operating the device must obtain authorization from the grid operator to connect the device regarding the harmonic currents.

 Harmonic currents (Page 79)

- **Inverters with an LO base load current > 75A**

There are no standard-related requirements for installing devices such as these. However, it is recommended to inform the grid operator when connecting such a device.

## 7.7.2 Radio interference suppression filters according to CISPR 11/EN 55011 Class B

Under the following preconditions, inverters, frame sizes FSA to FSC - equipped with Class B filters from Table 8-6 Assignment table (Page 89) - comply with the limit values for interference voltages at the power supply connection according to CISPR 11/EN 55011 Class B:

- The drive system is installed by appropriately qualified personnel in compliance with EMC regulations - and the installation notes provided in the manual.
- You use a shielded motor cable with low capacitance.
- The motor cable is shorter than 25 m.

## 7.7.3 Harmonic currents

Table 7- 11 Typical harmonic currents (%) of the inverter

Inverter	Harmonic number							
	5th	7th	11th	13th	17th	19th	23rd	25th
FSA ... FSGX <sup>1)</sup>	73	52	25	23	22	15	12	10

<sup>1)</sup> Values referred to the LO input current

#### 7.7.4 EMC limit values in South Korea

이 기기는 업무용(A 급) 전자파적합기기로서 판매자 또는 사용자는 이 점을 주의하시기 바라며, 가정외의 지역에서 사용하는 것을 목적으로 합니다.  
For sellers or users, please keep in mind that this device is an A-grade electromagnetic wave device. This device is intended to be used in areas other than home.

The EMC limit values to be observed for Korea correspond to the limit values of the EMC product standard for variable-speed electric drives EN 61800-3 of category C2 or the limit value class A, Group 1 to KN11.

By implementing appropriate additional measures, the limit values according to category C2 or limit value class A, Group 1, are observed.

Additional measures, such as the use of an additional RFI suppression filter (EMC filter), may be necessary. In addition, measures for EMC-compliant configuration of the plant are described in this manual and/or the "EMC installation guidelines" Configuration Manual.

The final statement on compliance with the applicable standard is given by the respective label attached to the individual device.

## Spare parts and accessories

### 8.1 Product maintenance

Inverter components are being continuously developed within the scope of product update. The product update includes, for example, measures to increase the ruggedness or hardware changes, which are necessary as components are being discontinued.

These further developments are "spare parts-compatible" and do not change the article number.

In the scope of such spare parts-compatible ongoing development, plug connector or connection positions are sometimes slightly modified. This does not cause any problems when the components are properly used. Please take this fact into consideration in special installation situations (e.g. allow sufficient reserve regarding the cable length).

### 8.2 Spare parts

#### Power Modules FSA

Fan kit 6SL3200-0SF12-0AA0 for 

- all FSA Power Modules

#### Power Modules FSB

Fan kit 6SL3200-0SF13-0AA0 for 

- all FSB Power Modules

#### Power Modules FSC

Fan kit 6SL3200-0SF14-0AA0 for 

- all Power Modules FSC

#### Power Modules FSD

Fan kit 6SL3200-0SF04-0AA0 for 

- 6SL3225-0BE31-5AA0 (18.5 kW)
- 6SL3225-0BE31-8AA0 (22 kW)

Fan kit 6SL3200-0SF05-0AA0 for 

- 6SL3225-0BE32-2AA0 (30 kW)

#### Power Modules FSE

Fan kit 6SL3200-0SF04-0AA0 for 

- 6SL3225-0BE33-0AA0 (37 kW)

Fan kit 6SL3200-0SF05-0AA0 for 

- 6SL3225-0BE33-7AA0 (45 kW)

Cover kit 6SL3200-0SM11-0AA0 for All Power Modules FSE

#### Power Modules FSF

Fan kit 6SL3200-0SF06-0AA0 for 

- 6SL3225-0BE34-5AA0 (55 kW)
- 6SL3225-0BE35-5AA0 (75 kW)

Fan kit 6SL3200-0SF08-0AA0 for 

- 6SL3225-0BE37-5AA0 (90 kW)

Cover kit 6SL3200-0SM12-0AA0 for all Power Modules FSF

## 8.3 Optional accessories

### Which components are available?

- Mounting frames for PT Power Modules - frame sizes FSA ... FSC
- Line reactor
- Line filter
- Output reactors
- Sine-wave filters
- Braking choppers - for FSGX, for FSA ... FSF integrated in the Power Module
- Braking resistor
- Brake Relay and Safe Brake Relay
- Adapter for mounting on DIN mounting rails - for FSA and FSB
- Shield mounting kit - not for FSGX



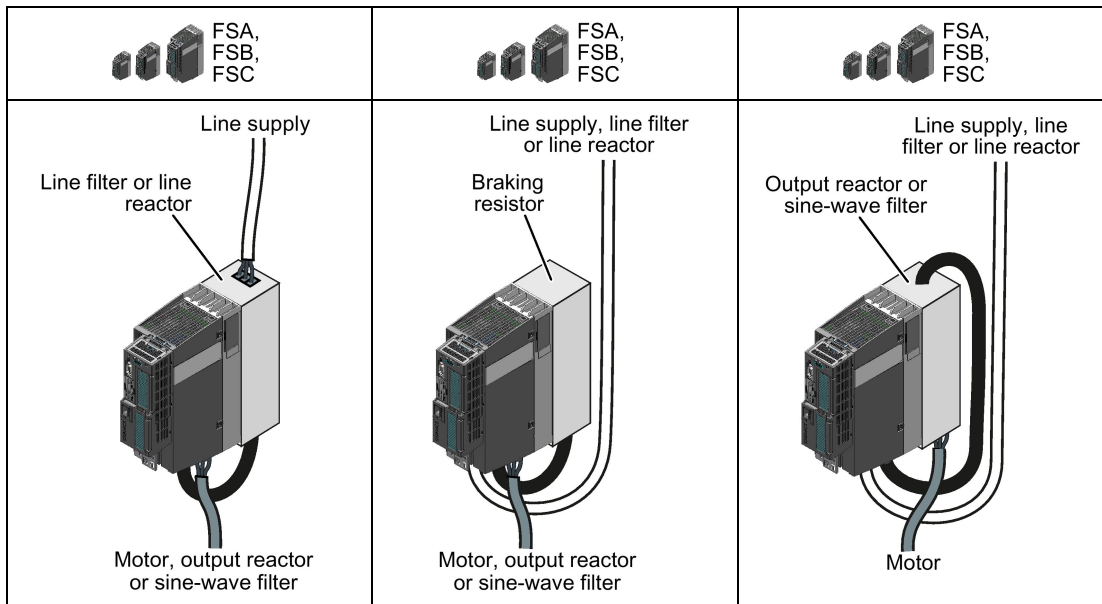

### 8.3.1 Base components for frame sizes FSA, FSB and FSC

Reactors, filters and braking resistors are available as base components for PM240 Power Modules, frame sizes FSA, FSB and FSC. An overview of the permitted base component combinations is provided below. You can also install base components next to the Power Module.

### Installing base components

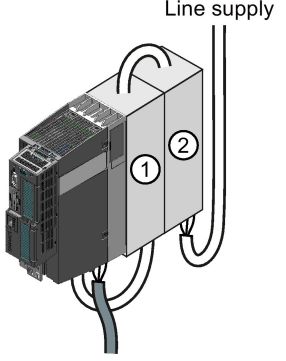
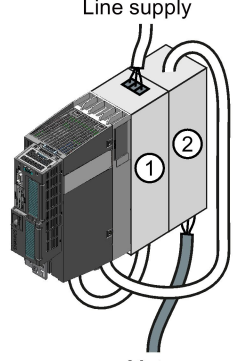
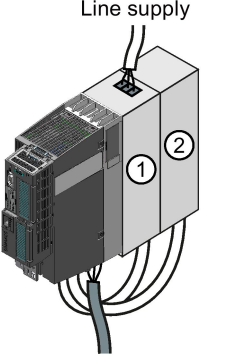
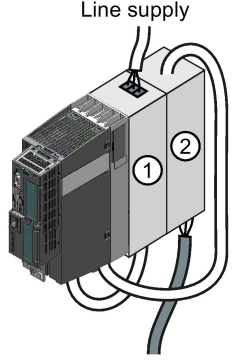

### Installing two base components

 FSA, FSB, FSC	 FSA, FSB, FSC	 <del>FSA</del> <del>FSB</del>	 <del>FSA</del>
<p>① Line filter</p> <p>② Line reactor</p>  <p>Line supply</p> <p>Motor, output reactor or sine-wave filter</p>	<p>① Line filter or line reactor</p> <p>② Output reactor</p>  <p>Line supply</p> <p>Motor</p>	<p>① Line filter or line reactor</p> <p>② Braking resistor</p>  <p>Line supply</p> <p>Motor, output reactor or sine-wave filter</p>	<p>① Line filter or line reactor</p> <p>② Sine-wave filter</p>  <p>Line supply</p> <p>Motor</p>

### Connection components

Connection overview for the electrical components  Connection overview (Page 43).

### 8.3.2 Line reactor

A line reactor protects the inverter when connected to dirty line supplies. A line reactor supports the overvoltage protection, smooths the harmonics in the line supply and buffers commutation dips.

The line reactors for Power Modules, frame sizes FSA ... FSC, are suitable for base mounting as well as for installation next to the inverter.

**Note**

**When do you require a line reactor?**

Without line reactor, the inverter is suitable for line supplies with  $U_k \geq 1\%$ . For  $U_k < 1\%$ , you must use a line reactor.

#### Mounting position

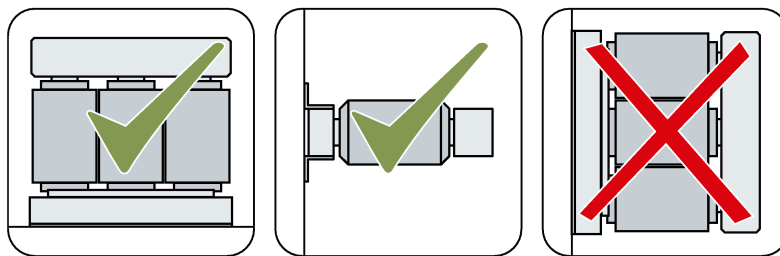

#### Clearances to other devices

For a line reactor, a minimum clearance to other devices must be maintained on all sides.

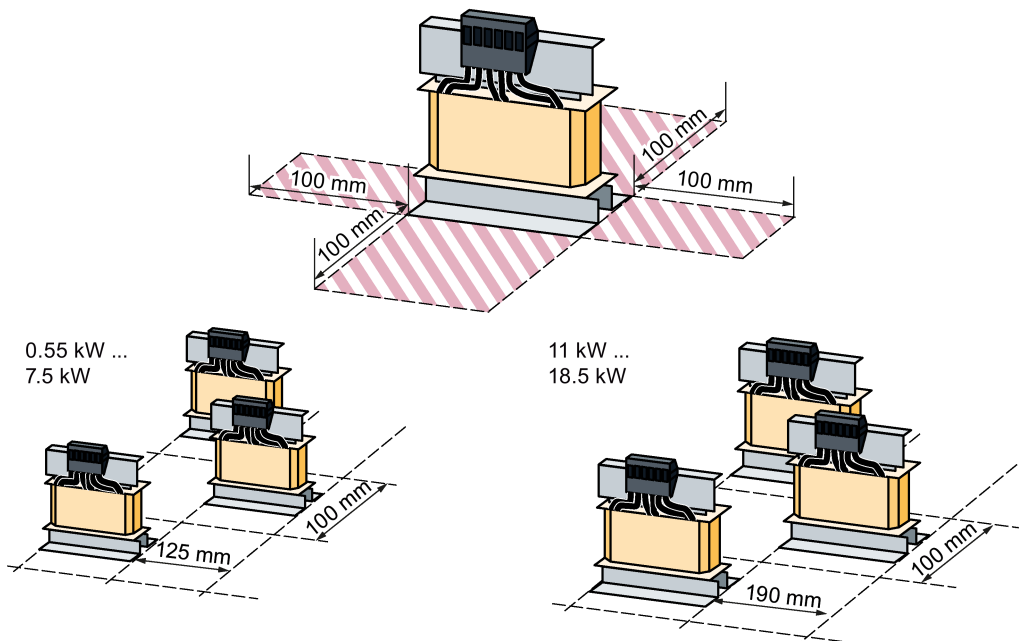

Figure 8-1 Clearances between the line reactors and other devices, examples for space-saving installation

Dimensions and drilling patterns

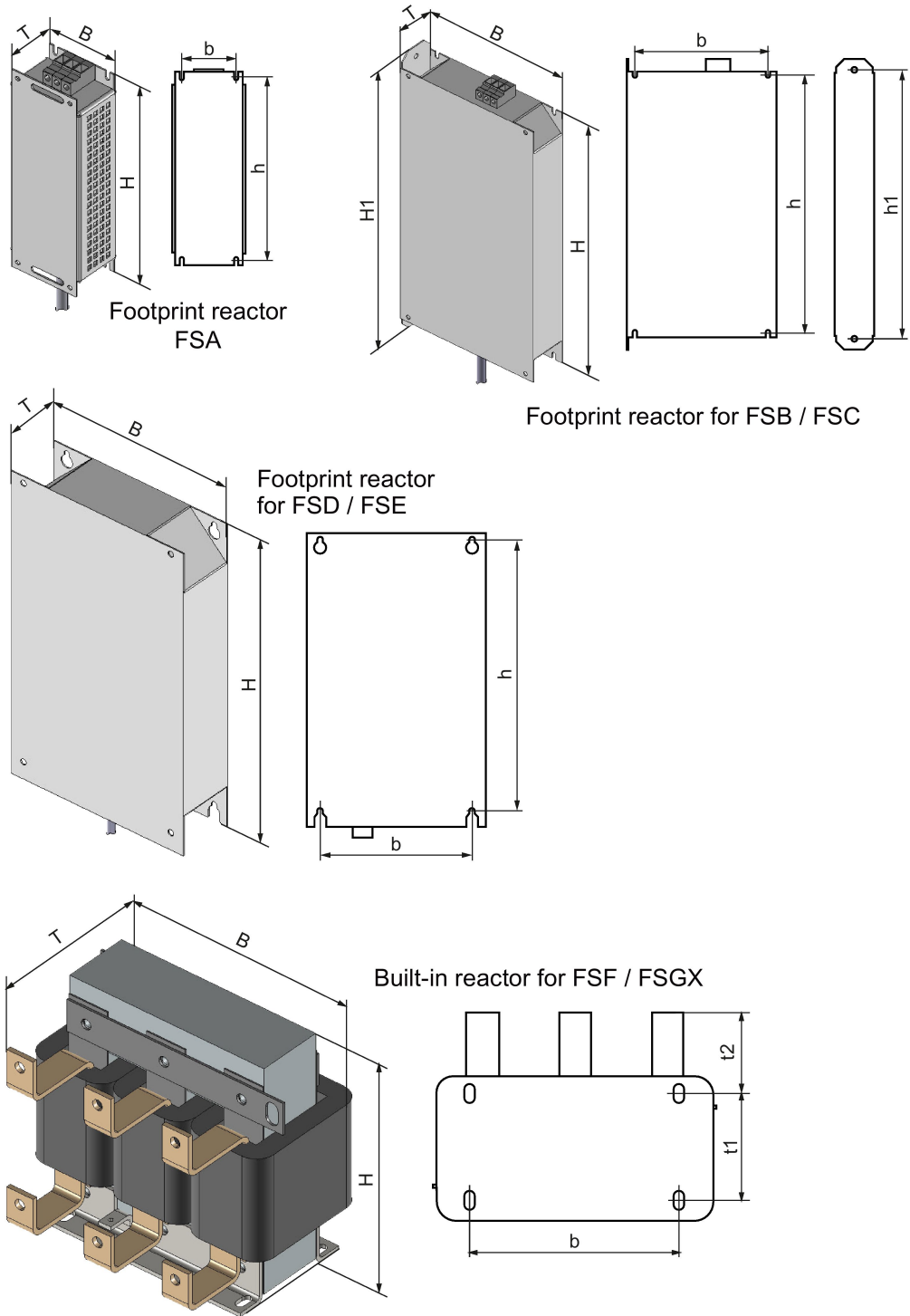

Figure 8-2 Line reactors

## 8.3 Optional accessories

Table 8- 1 Dimensions and weights

Article number	Overall dimensions (mm)				Drilling dimensions (mm)			Fixing/torque (Nm)	Weight (kg)
	W	H	H1	D	b	h	h1		
<b>For FSA ... FSD</b>									
6SE6400-3CC00-2AD3 6SE6400-3CC00-4AD3 6SE6400-3CC00-6AD3	75.5	200	---	50	56	187	---	4 x M4 / 2.5	1.3
6SL3203-0CD21-0AA0 6SL3203-0CD21-4AA0	153	270	290	50	133	258	277	4 x M4 / 2.5	3.4
6SL3203-0CD22-2AA0 6SL3203-0CD23-5AA0	189	336	371	50	167	324	343	4 x M5 / 3	6.4
6SL3203-0CJ24-5AA0 6SL3203-0CD25-3AA0	275	455	---	84	235	421	---	4 x M8 / 25	13
<b>for FSE ... FSGX</b>	<b>W</b>	<b>H</b>	<b>H1</b>	<b>D</b>	<b>b</b>	<b>t1</b>	<b>t2</b>		
6SL3203-0CJ28-6AA0	275	577	---	94	235	543	---	4 x M8 / 25	19
6SE6400-3CC11-2FD0 6SE6400-3CC11-7FD0	240	228	---	159	190	115	29	4 x M10 / 47	25
6SL3000-0CE32-3AA0 6SL3000-0CE32-8AA0	270	248	---	200	200	102	77	4 x M8 / 25	26
6SL3000-0CE33-3AA0	270	248	---	200	200	102	77	4 x M8 / 25	27.8
6SL3000-0CE35-1AA0	300	262	---	214	224	120	80	4 x M8 / 25	38

## Technical data and assignment tables

Table 8- 2 Technical data

Article number	Inductance (mH)	Power loss (W) for 50 / 60 Hz	Connection (mm <sup>2</sup> )			Degree of protection
			Line supply	Power Module	PE	
6SE6400-3CC00-2AD3 6SE6400-3CC00-4AD3 6SE6400-3CC00-6AD3	11.5 mH 6.3 mH 3.2 mH	6 / 7 12.5 / 15 7.5 / 9	1 ... 2.5 mm <sup>2</sup> , 0.8 ... 1 Nm	Integrated, 370 mm	M5 / 3 Nm	IP20
6SL3203-0CD21-0AA0 6SL3203-0CD21-4AA0	2.2 mH 1.3 mH	9 / 11 27 / 32				
6SL3203-0CD22-2AA0 6SL3203-0CD23-5AA0	0.56 mH 0.28 mH	98 / 118 37 / 44				
6SL3203-0CJ24-5AA0 6SL3203-0CD25-3AA0	0.41 mH 0.29 mH	90 / 115 90 / 115	16 mm <sup>2</sup>	Integrated, 700 mm	M8 / 25 Nm	IP20
6SL3203-0CJ28-6AA0	0.22 mH	170 / 215	35 mm <sup>2</sup>	Integrated, 700 mm	M8 / 25 Nm	IP20
6SE6400-3CC11-2FD0	0.15 mH	280 / 360	M10 cable lug		M8 studs	IP20
6SE6400-3CC11-7FD0	90 µH	280 / 360	M10 cable lug		M8 studs	IP00
6SL3000-0CE32-3AA0	76 µH	240 / 270	M10 cable lug		M8 studs	IP00

Article number	Inductance (mH)	Power loss (W) for 50 / 60 Hz	Connection (mm <sup>2</sup> )			Degree of protection
			Line supply	Power Module	PE	
6SL3000-0CE32-8AA0	62 µH	210 / 250	M10 cable lug		M8 studs	IP00
6SL3000-0CE33-3AA0	52 µH	270 / 270	M10 cable lug		M8 studs	IP00
6SL3000-0CE35-1AA0	42 µH	365 / 365	M14 cable lug		M8 screw	IP00

Table 8- 3 Assignment table

Line reactor	Power Module		Frame size
Article number	Article number	Article number	
6SE6400-3CC00-2AD3	6SL3224-0BE13-7UA0	6SL3224-0BE15-5UA0	FSA
6SE6400-3CC00-4AD3	6SL3224-0BE17-5UA0	6SL3224-0BE21-1UA0	FSA
6SE6400-3CC00-6AD3	6SL3224-0BE21-5UA0		FSA
6SL3203-0CD21-0AA0	6SL3224-0BE22-2 . A0	6SL3224-0BE23-0 . A0	FSB
6SL3203-0CD21-4AA0	6SL3224-0BE24-0 . A0		FSB
6SL3203-0CD22-2AA0	6SL3224-0BE25-5 . A0	6SL3224-0BE27-5 . A0	FSC
6SL3203-0CD23-5AA0	6SL3224-0BE31-1 . A0		FSC
6SL3203-0CJ24-5AA0	6SL3224-0BE31-5 . A0	6SL3224-0BE31-8 . A0	FSD
6SL3203-0CD25-3AA0	6SL3224-0BE32-2 . A0		FSD
6SL3203-0CJ28-6AA0	6SL3224-0BE33-0 . A0	6SL3224-0BE33-7 . A0	FSE
6SE6400-3CC11-2FD0	6SL3224-0BE34-5 . A0	6SL3224-0BE35-5 . A0	FSF
6SE6400-3CC11-7FD0	6SL3224-0BE37-5 . A0		FSF
6SL3000-0CE32-3AA0	6SL3224-0BE38-8UA0		FSF
6SL3000-0CE32-8AA0	6SL3224-0BE41-1UA0		FSF
6SL3000-0CE33-3AA0	6SL3224-0XE41-3UA0		FSGX
6SL3000-0CE35-1AA0	6SL3224-0XE41-6UA0	6SL3224-0XE42-0UA0	FSGX

. : A with integrated filter, U device without filter

### 8.3.3 Line filter

With a line filter, the inverter can achieve a higher radio interference class.

The line filters integrated in the inverter correspond to Category C2 according to EN 61800-3.

External filters are available for Category C2 or C1 according to EN 61800-3. Details are provided in the following tables.

**NOTICE**

**The line filter is damaged when operated on inadmissible line supplies**

The line filter is only suitable for operation on TN or TT line systems with a grounded neutral point. The line filter is damaged if operated on all other line supplies.

- For inverters equipped with line filter, only connect to TN or TT line systems with a grounded neutral point.

### Dimensions and drilling patterns

Mounting dimensions

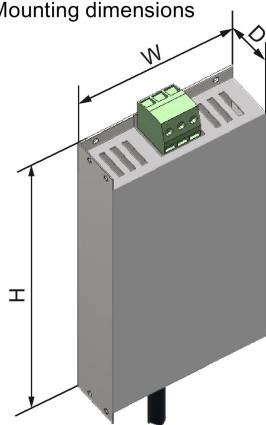

Drilling dimensions

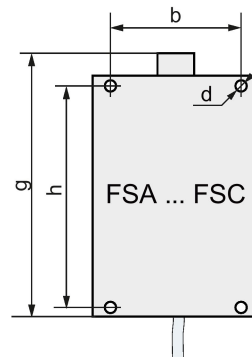
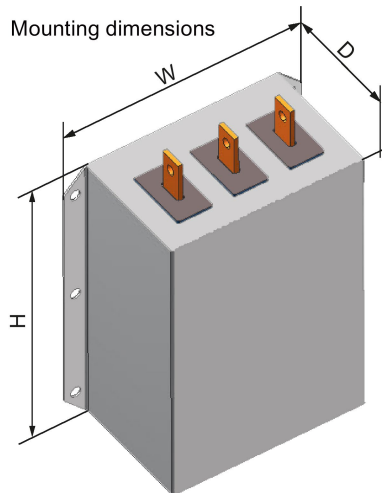

Figure 8-3 Line filters, FSA ... FSC

Mounting dimensions



Drilling dimensions

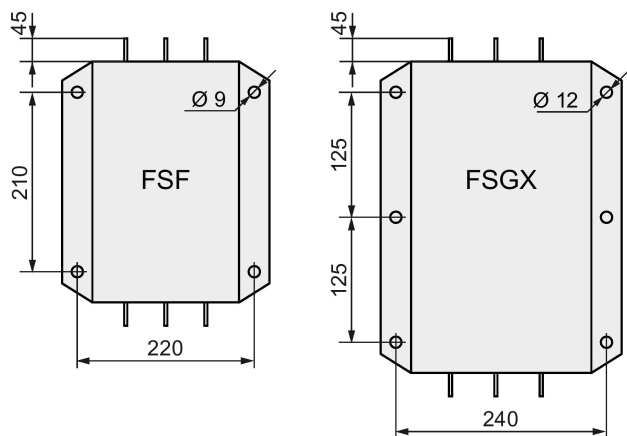

Figure 8-4 Line filters FSF, FSGX

Table 8- 4 Dimensions and weights

Article number	Overall dimensions (mm)			Drilling dimensions (mm)				Weight (kg)
	W	H	D	b	h	g	Fixing/torque (Nm)	
6SE6400-2FA00-6AD0 6SE6400-2FB00-6AD0	73	200	43.5	56	187	205.5	4 x M4 / 2.5	0.6
6SL3203-0BE21-6SA0	153	296	50	120	200	315	4 x M4 / 2.5	1.5
6SL3203-0BD23-8SA0	189	362	55	156	232	381	4 x M5 / 3	2.3
6SL3203-0BE32-5AA0	240	360	116				4 x M8 / 25	12.4
6SL3000-0BE36-0AA0	400	265	140				4 x M10 / 47	19

## Technical data and assignment tables

Table 8- 5 Technical data

Article number	Power loss (W) at 50 Hz	Connection (mm <sup>2</sup> )		Degree of protection
		Line supply / PE	Power Module	
6SE6400-2FA00-6AD0 6SE6400-2FB00-6AD0	0.5 ... 1.5	Screw terminals 2.5 mm <sup>2</sup>	Integrated, 400 mm	IP20
6SL3203-0BE21-6SA0	2 ... 4	Screw terminals 2.5 mm <sup>2</sup>	Integrated, 400 mm	IP20
6SL3203-0BD23-8SA0	7.5 ... 15	4 mm <sup>2</sup> screw terminals	Integrated, 400 mm	IP20
6SL3203-0BE32-5AA0	60	M8 studs	M8 studs	IP00
6SL3000-0BE36-0AA0	55	M10 connecting lugs	M10 connecting lugs	IP00

Table 8- 6 Assignment table

Line filter		Power Module		Frame size
Article number	Class	Article number		
6SE6400-2FA00-6AD0	A	6SL3224-0BE13-7UA0	6SL3224-0BE15-5UA0	FSA
6SE6400-2FB00-6AD0	B	6SL3224-0BE17-5UA0 6SL3224-0BE21-5UA0	6SL3224-0BE21-1UA0	
6SL3203-0BE21-6SA0	B	6SL3224-0BE22-2AA0 6SL3224-0BE24-0AA0	6SL3224-0BE23-0AA0	FSB
6SL3203-0BD23-8SA0	B	6SL3224-0BE25-5AA0 6SL3224-0BE31-1AA0	6SL3224-0BE27-5AA0	FSC
6SL3203-0BE32-5AA0	A	6SL3224-0BE38-8UA0	6SL3224-0BE41-1UA0	FSF
6SL3000-0BE36-0AA0	A	6SL3224-0XE41-3UA0 6SL3224-0XE42-0UA0	6SL3224-0XE41-6UA0	FSGX

### 8.3.4 Output reactor

#### Mounting position

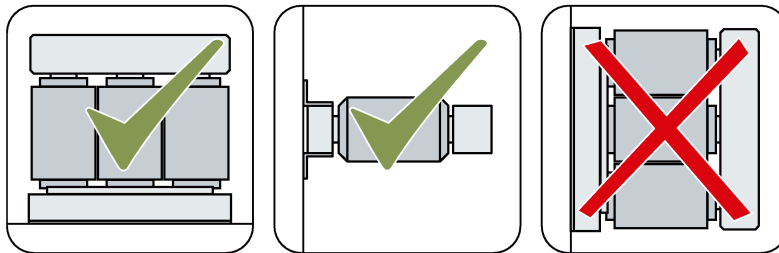

#### Clearances to other devices

Keep shaded areas free of any devices and components.

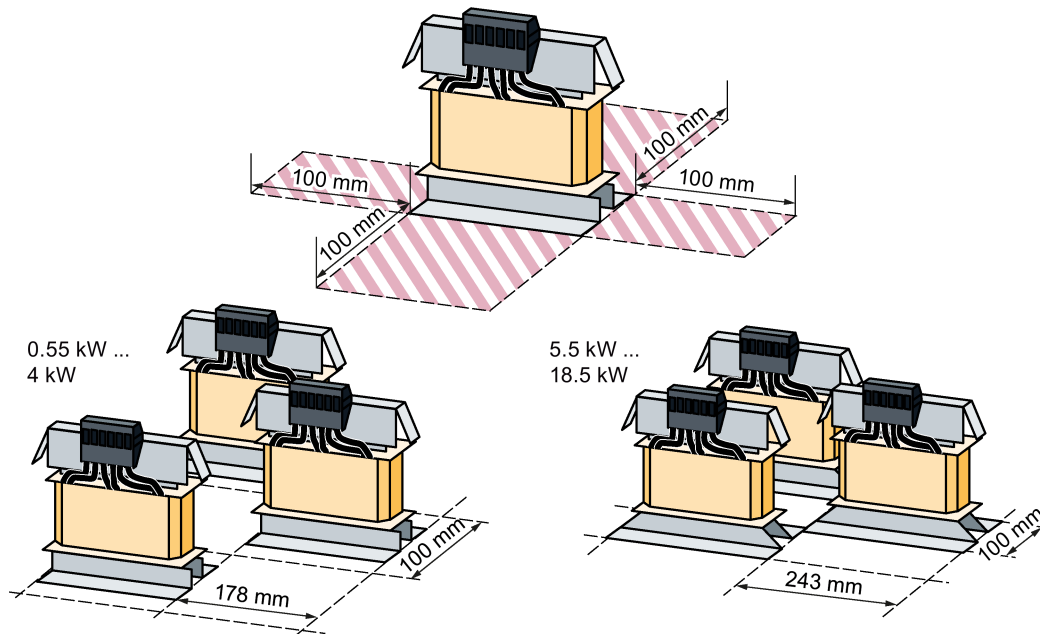

Figure 8-5 Minimum clearances of the output reactor to other devices, space-saving mounting examples

When using the output reactor it is not permissible that the output frequency exceeds 150 Hz  
It is not permissible that the pulse frequency exceeds 4 kHz

Dimensions and drilling patterns

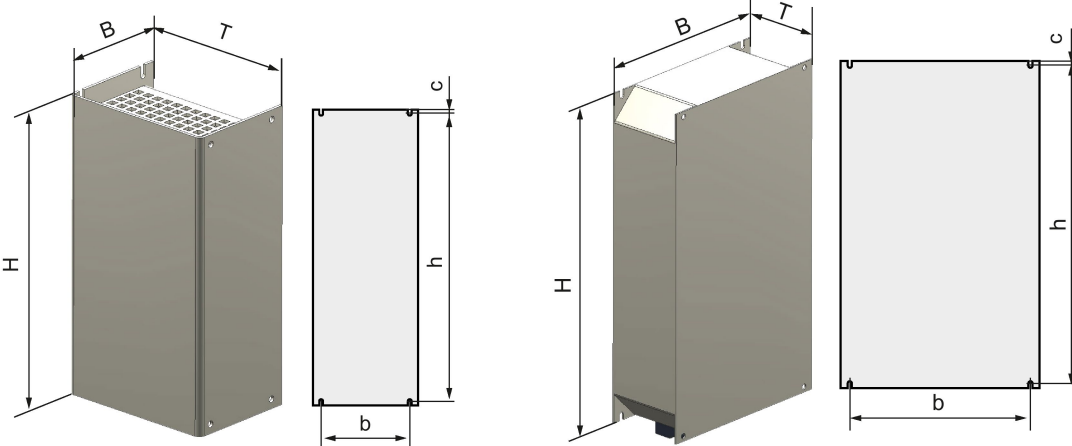

Figure 8-6 Output reactors as base component for frame sizes FSA ... FSC

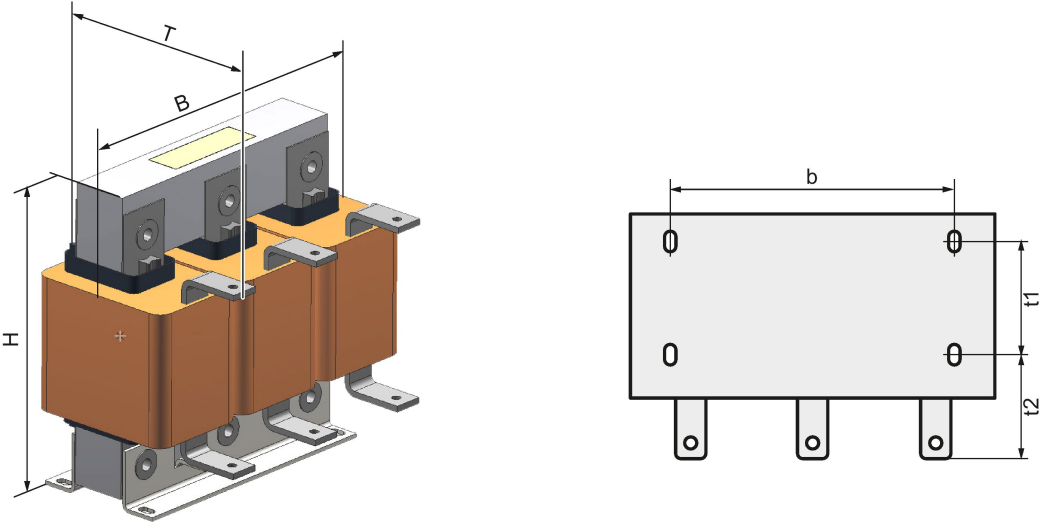

Figure 8-7 Standalone output reactors for frame sizes FSD ... FSGX

Table 8- 7 Dimensions and weights

Article number	Overall dimensions (mm)			Drilling dimensions (mm)			Fixing/torque (Nm)	Weight (kg)
	<b>Reactors that can be mounted as base component</b>							
	<b>W</b>	<b>H</b>	<b>D</b>	<b>b</b>	<b>h</b>	<b>c</b>		
6SE6400-3TC00-4AD2	75.5	200	110	56	187	6.5	4 x M4 / 2.5	1.9
6SL3202-0AE21-0CA0	154	270	70	120	200	6.5	4 x M4 / 2.5	4.4
6SL3202-0AJ23-2CA0	189	334	80	156	232	5.5	4 x M5 / 3	9
	<b>Reactors that cannot be mounted as base component</b>							
	<b>W</b>	<b>H</b>	<b>D</b>	<b>b</b>	<b>t1</b>	<b>t2</b>		
6SE6400-3TC05-4DD0	225	210	150	176	69	70.5	4 x M6 / 7	11.5
6SE6400-3TC03-8DD0	225	210	179	176	93	75.5	4 x M6 / 7	19
6SE6400-3TC05-4DD0	225	210	140	138	264		4 x M6 / 7	11.5
6SE6400-3TC08-0ED0	225	210	150	176	69	70.5	4 x M6 / 7	12
6SE6400-3TC07-5ED0	270	248	209	200	102	91.5	4 x M8 / 25	26.5
6SE6400-3TC14-5FD0	350	321	288	264	140	134	4 x M8 / 25	57
6SE6400-3TC15-4FD0	270	248	209	200	102	90	4 x M8 / 25	24
6SE6400-3TC14-5FD0	350	321	288	264	140	134	4 x M8 / 25	57
6SL3000-2BE32-1AA0	300	285	257	224	165	78	4 x M8 / 25	60
6SL3000-2BE32-6AA0	300	315	277	224	185	78	4 x M8 / 25	60
6SL3000-2BE33-2AA0	300	285	257	224	165	78	4 x M8 / 25	62
6SL3000-2BE33-8AA0	300	285	277	224	185	78	4 x M8 / 25	73
6SL3000-2BE35-0AA0	300	365	277	224	185	78	4 x M10 / 47	100

## Technical data and assignment tables

Table 8- 8 Technical data

Article number	Connection (mm <sup>2</sup> )			De- gree of protec- tion	Power loss (W)
	Line supply	Power Module	PE		
6SE6400-3TC00-4AD2	Screw terminals 2.5 mm <sup>2</sup>	Integrated, 350 mm	M5 studs	IP20	5
6SL3202-0AE21-0CA0	6 mm <sup>2</sup> screw terminals	Integrated, 40 mm	M5 studs	IP00	20
6SL3202-0AJ23-2CA0	6 mm <sup>2</sup> screw terminals	Integrated, 350 mm	M5 studs	IP00	60
6SE6400-3TC05-4DD0	M6 cable lug		M6 screw	IP00	200
6SE6400-3TC03-8DD0	M6 cable lug		M6 screw	IP00	200
6SE6400-3TC08-0ED0	M6 cable lug		M6 screw	IP00	170
6SE6400-3TC07-5ED0	M6 cable lug		M6 screw	IP00	277
6SE6400-3TC14-5FD0	M8 cable lug		M8 screw	IP00	469
6SE6400-3TC15-4FD0	M8 cable lug		M6 screw	IP00	245

Article number	Connection (mm <sup>2</sup> )			De- gree of protec- tion	Power loss (W)
	Line supply	Power Module	PE		
6SL3000-2BE32-1AA0	M10 cable lug		M8 screw	IP00	486
6SL3000-2BE32-6AA0	M10 cable lug		M8 screw	IP00	500
6SL3000-2BE33-2AA0	M10 cable lug		M8 screw	IP00	470
6SL3000-2BE33-8AA0	M10 cable lug		M8 screw	IP00	500
6SL3000-2BE35-0AA0	M12 cable lug		M8 screw	IP00	500

Table 8- 9 Assignment table

Output reactor	Power Module		Frame size
Article number	Article number		
6SE6400-3TC00-4AD2	6SL3224-0BE13-7UA0 6SL3224-0BE17-5UA0 6SL3224-0BE21-5UA0	6SL3224-0BE15-5UA0 6SL3224-0BE21-1UA0	FSA
6SL3202-0AE21-0CA0	6SL3224-0BE22-2 . A0 6SL3224-0BE24-0 . A0	6SL3224-0BE23-0 . A0	FSB
6SL3202-0AJ23-2CA0	6SL3224-0BE25-5 . A0 6SL3224-0BE31-1 . A0	6SL3224-0BE27-5 . A0	FSC
6SE6400-3TC05-4DD0	6SL3224-0BE31-5 . A0		FSD
6SE6400-3TC03-8DD0	6SL3224-0BE31-8 . A0		FSD
6SE6400-3TC05-4DD0	6SL3224-0BE32-2 . A0		FSD
6SE6400-3TC08-0ED0	6SL3224-0BE33-0 . A0		FSE
6SE6400-3TC07-5ED0	6SL3224-0BE33-7 . A0		FSE
6SE6400-3TC14-5FD0	6SL3224-0BE34-5 . A0		FSF
6SE6400-3TC15-4FD0	6SL3224-0BE35-5 . A0		FSF
6SE6400-3TC14-5FD0	6SL3224-0BE37-5 . A0		FSF
6SL3000-2BE32-1AA0	6SL3224-0BE38-8UA0		FSF
6SL3000-2BE32-6AA0	6SL3224-0BE41-1UA0		FSF
6SL3000-2BE33-2AA0	6SL3224-0XE41-3UA0		FSGX
6SL3000-2BE33-8AA0	6SL3224-0XE41-6UA0		FSGX
6SL3000-2BE35-0AA0	6SL3224-0XE42-0UA0		FSGX

### 8.3.5 Sine-wave filter

The sine-wave filter at the inverter output limits the voltage rate-of-rise and the peak voltages at the motor winding. The maximum permissible length of motor feeder cables is increased to 300 m.

The following applies when using a sine-wave filter:

- Operation is only permissible with pulse frequencies from 4 kHz to 8 kHz. From 110 kW power rating of the Power Modules (according to the rating plate) only 4 kHz is permissible.
- The inverter power is reduced by 5%.
- The maximum output frequency of the inverter is 150 Hz at 380 V to 480 V.
- Operation and commissioning may only be performed with the motor connected, as the sine-wave filter is not no-load proof.
- An output reactor is superfluous.

#### Dimensions, drilling patterns and weights

##### FSA ... FSC footprint filters (base component)

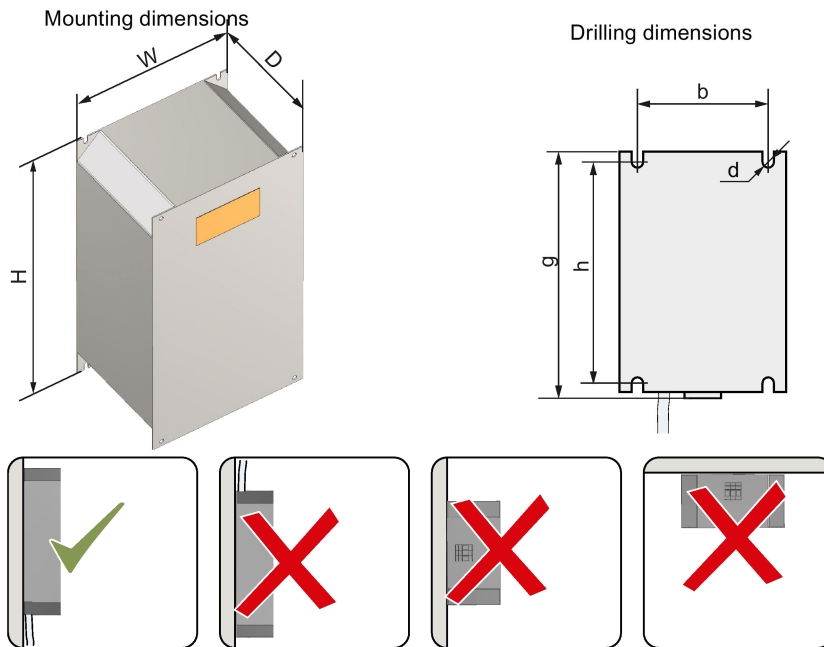

Sine-wave filter	Overall dimensions (mm)			Drilling dimensions (mm)			Fixing/torque (Nm)	Weight (kg)
	W	H	D	b	h	g		
6SL3202-0AE20-3SA0	75.5	200	110	56	187	202	4 x M4 / 2	2.6
6SL3202-0AE20-6SA0	75.5	200	110	56	187	202	4 x M4 / 2	3
6SL3202-0AE21-1SA0	153	270	100	133	258	286.5	4 x M4 / 2	6
6SL3202-0AE21-4SA0	153	270	100	133	258	286.5	4 x M4 / 2	10
6SL3202-0AE22-0SA0	189	336	140	167	323	351.5	4 x M5 / 3	12
6SL3202-0AE23-3SA0	189	336	140	167	323	351.5	4 x M5 / 3	23

## Sine-wave filter - stand alone, frame size 1

Mounting dimensions

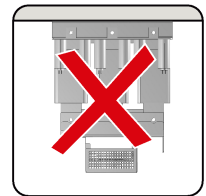
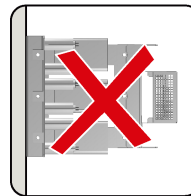
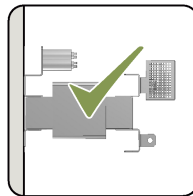
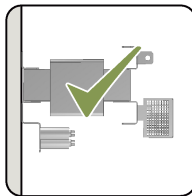
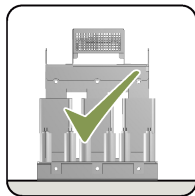
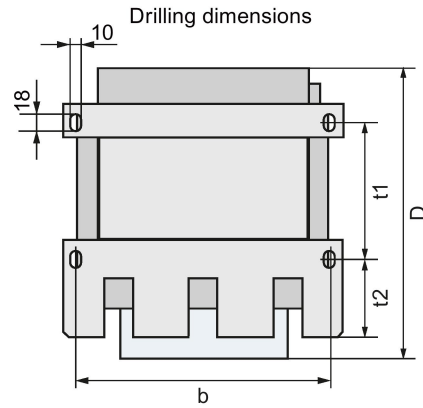
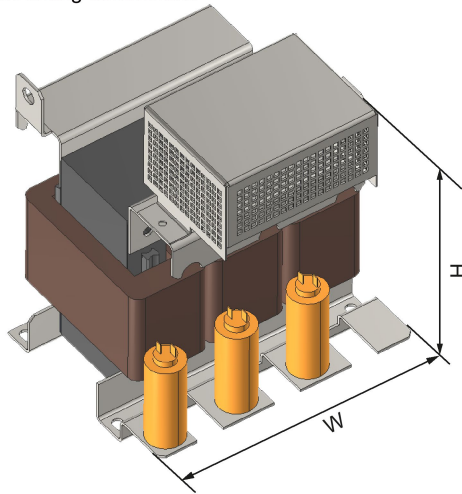

Sine-wave filter	Overall dimensions (mm)			Drilling dimensions (mm)			Fixing/torque (Nm)	Weight (kg)
	W	H	D	b	t1	t2		
6SL3202-0AE24-6SA0	250	305	262	230	127	90.5	4 x M6 / 7	24
6SL3202-0AE26-2SA0	250	315	262	230	127	90.5	4 x M6 / 7	34
6SL3202-0AE28-8SA0	275	368	275	250	132	100.5	4 x M8 / 13	45
6SL3202-0AE31-5SA0	350	440	305	320	156.5	113	4 x M8 / 13	63
6SL3202-0AE31-8SA0	350	468	305	320	156.5	113	4 x M8 / 13	80

Sine-wave filter - stand alone, frame size 2

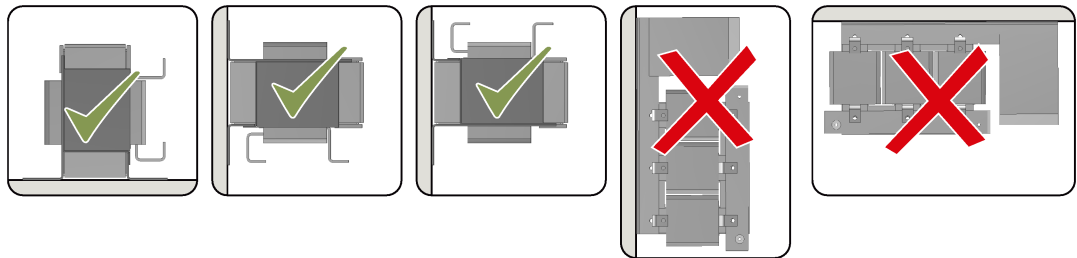
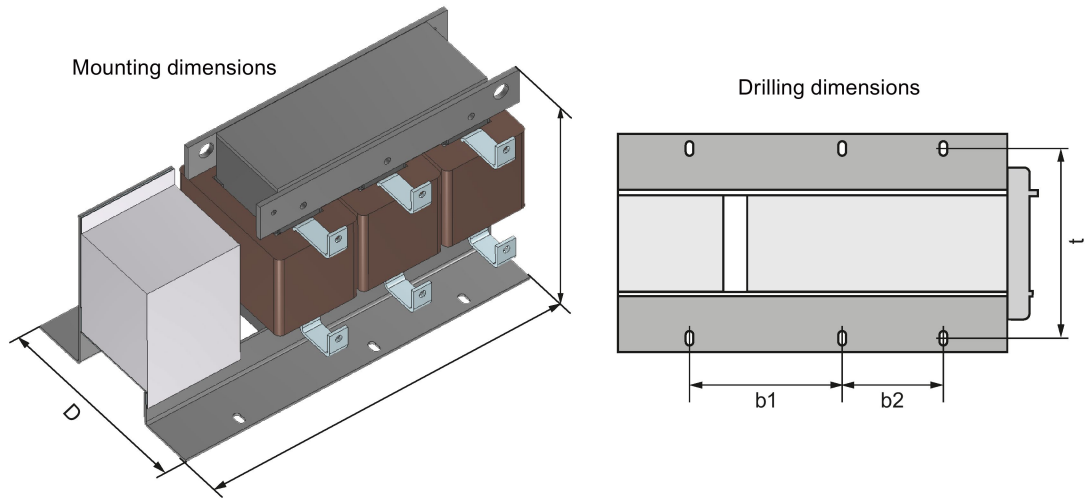

Sine-wave filter	Overall dimensions (mm)			Drilling dimensions (mm)			Fixing/torque (Nm)	Weight (kg)
	W	H	D	b1	b2	t		
6SL3000-2CE32-3AA0	620	300	320	225	150	280	6 x M10 / 20	124
6SL3000-2CE32-8AA0	620	300	320	225	150	280	6 x M10 / 20	127
6SL3000-2CE33-3AA0	620	370	360	225	150	320	6 x M10 / 20	136
6SL3000-2CE34-1AA0	620	370	360	225	150	320	6 x M10 / 20	198

Technical data and assignment tables

Table 8- 10 Technical data

Article number	P <sub>loss</sub> <sup>1)</sup> (W)	Connection		Degree of protection
		Power Module	Motor	
6SL3202-0AE20-3SA0	10	Integrated 500 mm	Screw terminals 6 mm <sup>2</sup>	IP20
6SL3202-0AE20-6SA0	20	Integrated 500 mm	Screw terminals 6 mm <sup>2</sup>	IP20
6SL3202-0AE21-1SA0	22	Integrated 500 mm	Screw terminals 6 mm <sup>2</sup>	IP20
6SL3202-0AE21-4SA0	36	Integrated 500 mm	Screw terminals 6 mm <sup>2</sup>	IP20
6SL3202-0AE22-0SA0	40	Integrated 500 mm	Screw terminals 6 mm <sup>2</sup>	IP20

Article number	P <sub>loss</sub> <sup>1)</sup> (W)	Connection		Degree of protection
		Power Module	Motor	
6SL3202-0AE23-3SA0	65	Integrated 500 mm	Screw terminals 6 mm <sup>2</sup>	IP20
6SL3202-0AE24-6SA0	80	Screw terminals 25 ... 50 mm <sup>2</sup>		IP20
6SL3202-0AE26-2SA0	65	Screw terminals 25 ... 50 mm <sup>2</sup>		IP20
6SL3202-0AE28-8SA0	100	Screw terminals 25 ... 95 mm <sup>2</sup>		IP20
6SL3202-0AE31-5SA0	180	Screw terminals 50 ... 150 mm <sup>2</sup>		IP20
6SL3202-0AE31-8SA0	190	Screw terminals 50 ... 150 mm <sup>2</sup>		IP20
6SL3000-2CE32-3AA0	200	Flat connector for M10 cable lug		IP20
6SL3000-2CE32-8AA0	230	Flat connector for M10 cable lug		IP00
6SL3000-2CE33-3AA0	180	Flat connector for M10 cable lug		IP00
6SL3000-2CE34-1AA0	230	Flat connector for M10 cable lug		IP00

<sup>1)</sup> Power loss at 50 Hz

Table 8- 11 Assignment table

Sine-wave filters	Power Module		
Article number	Article number	Power (kW)	Frame size
6SL3202-0AE20-3SA0	6SL3224-0BE13-7UA0 6SL3224-0BE17-5UA0	6SL3224-0BE15-5UA0 0.37 ... 0.75	FSA
6SL3202-0AE20-6SA0	6SL3224-0BE21-1UA0	6SL3224-0BE21-5UA0 1.1 ... 1.5	FSB
6SL3202-0AE21-1SA0	6SL3224-0BE22-2 . A0	6SL3224-0BE23-0 . A0 2.2 ... 3	
6SL3202-0AE21-4SA0	6SL3224-0BE24-0 . A0 4		FSC
6SL3202-0AE22-0SA0	6SL3224-0BE25-5 . A0 5.5		
6SL3202-0AE23-3SA0	6SL3224-0BE27-5 . A0	6SL3224-0BE31-1 . A0 17.5 ... 11	FSD
6SL3202-0AE24-6SA0	6SL3224-0BE31-5 . A0	6SL3224-0BE31-8 . A0 15 ... 18.5	
6SL3202-0AE26-2SA0	6SL3224-0BE32-2 . A0 22		
6SL3202-0AE28-8SA0	6SL3224-0BE33-0 . A0	6SL3224-0BE33-7 . A0 30 ... 37	FSE
6SL3202-0AE31-5SA0	6SL3224-0BE34-5 . A0	6SL3224-0BE35-5 . A0 45 ... 55	FSF
6SL3202-0AE31-8SA0	6SL3224-0BE37-5 . A0 75		
6SL3000-2CE32-3AA0	6SL3224-0BE38-8UA0	6SL3224-0BE41-1UA0 90 ... 110	FSGX
6SL3000-2CE32-8AA0	6SL3224-0XE41-3UA0 132		
6SL3000-2CE33-3AA0	6SL3224-0XE41-6UA0 160		
6SL3000-2CE34-1AA0	6SL3224-0XE42-0UA0 200		

### 8.3.6 Braking Module - only FSGX



The Braking Module controls the external braking resistor.

For frame sizes FSA ... FSF, it is integrated in the Power Module.

The Braking Module can be ordered as accessory for the power Module FSGX.  
Article number: 6SL33-001AE32-5AA0).

#### Installing the Braking Module

The Braking Module is installed at the top in the FSGX Power Module.

1. First remove the front cover of the Power Module.  Connections FSGX (Page 48)
2. Release the three screws from the side cover plate ①. Remove the cover plate.
3. Release the nine screws of the upper cover ②. Remove the cover.
4. Release the three screws from the mounting plate. Remove the mounting plate.
5. Locate the Braking Module at the position of the mounting plate and fix it using the mounting plate screws.
6. Establish the connections and set the threshold switch to the required position.  Braking Module - settings and connections (Page 99)
7. Reattach the covers in the inverse sequence.

You have now installed the Braking Module.

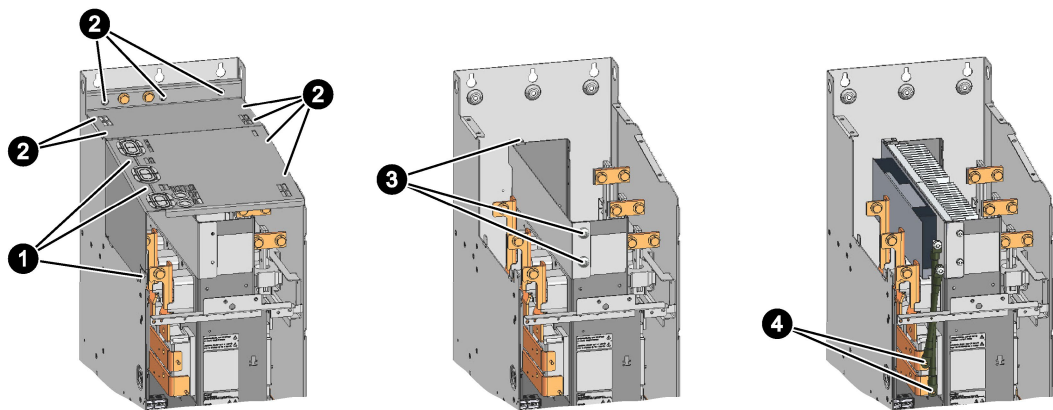

Figure 8-8 Installing the Braking Module

### 8.3.6.1 Braking Module - settings and connections

#### Threshold switch

Using the threshold switch, you set at which DC link voltage the braking resistor is switched in. It is only permissible that you change the setting of the threshold switch in the voltage-free state.

- "Lower" switch position (factory setting):  
The chopper switches in the braking resistor at a DC link voltage of 774 V. With this switch setting, you use 100 % of the braking power.
- "Upper" switch position  
The chopper switches-in the braking resistor at a DC voltage of 673 V. This means that you reduce the voltage stress on the motor as well as the inverter; however, the braking power is reduced by 25 %

#### Terminal block -X21

Terminal block-X21 has a digital input and a digital output. Using the digital input you can inhibit or release the Braking Module. The digital output indicates when the braking resistor is active.

Terminal 1	Shield	Shield potential for terminals 1 ... 6	
Terminal 2:	0 V	Low signal: Braking Module enabled	Signal level: Low: - 3 ... 5 V, high: 15 ... 30 V
Terminal 3	Digital input	High signal: Braking Module inhibited	
Terminal 4	0 V	High signal: Braking resistor not active	
Terminal 5	Digital output	Low signal: Braking resistor active	
Terminal 6	+ 24 V DC	18 ... 30 V, typical current drain at 24 V: 10 mA	

#### Connections for DC link and braking resistor

- Braking resistor: R1 and R2
- DC link: DCPA and DCNA

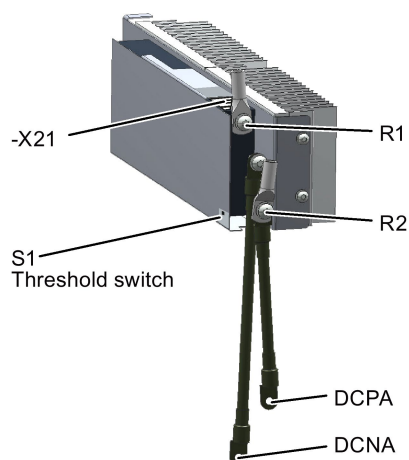

Figure 8-9 Connections and settings at the Braking Module

### 8.3.7 Braking resistor

The braking resistor enables loads with a large moment of inertia to be braked quickly. During braking of the motor and the load, excess energy is fed back to the converter. This causes the voltage to rise in the DC link. The converter transfers the excess energy to the externally mounted braking resistor.



**! WARNING**

**Danger to life due to fire spreading because of an unsuitable or improperly installed braking resistor**

Using an unsuitable or improperly installed braking resistor can cause fires and smoke to develop. Fire and smoke development can cause severe personal injury or material damage.

- Only use braking resistors that are approved for the inverter.
- Install the braking resistor in accordance with regulations.
- Monitor the temperature of the braking resistor.

#### Mounting position

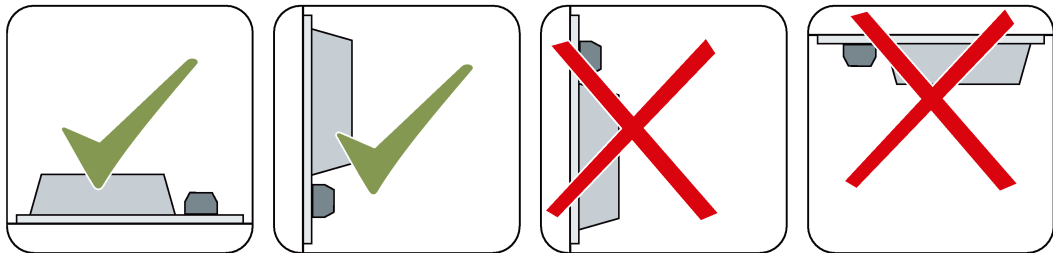

#### Mounting instructions

Mount the resistor on a heat resistant surface with a high thermal conductivity.

Do not cover the ventilation openings of the braking resistor.

You can mount the braking resistor either outside or inside the switchgear room. When mounted outside, the cooling air requirement for the switchgear room is lower.

#### Clearances to other devices

The following data are applicable for devices, frame sizes FSA ... FSC.

The clearances for braking resistors for devices, frame sizes FSD ... FSF are specified in the documentation, which is supplied with the braking resistor.

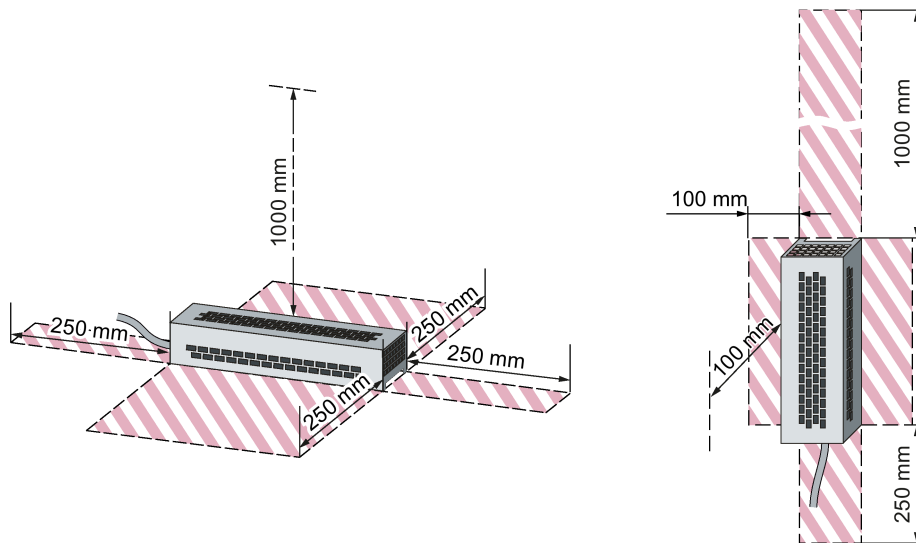

Figure 8-10 Minimum clearances for the braking resistor when mounting on a flat surface and for wall/panel mounting

Keep shaded areas free of any devices and components.

### Dimensions, drilling pattern und weights

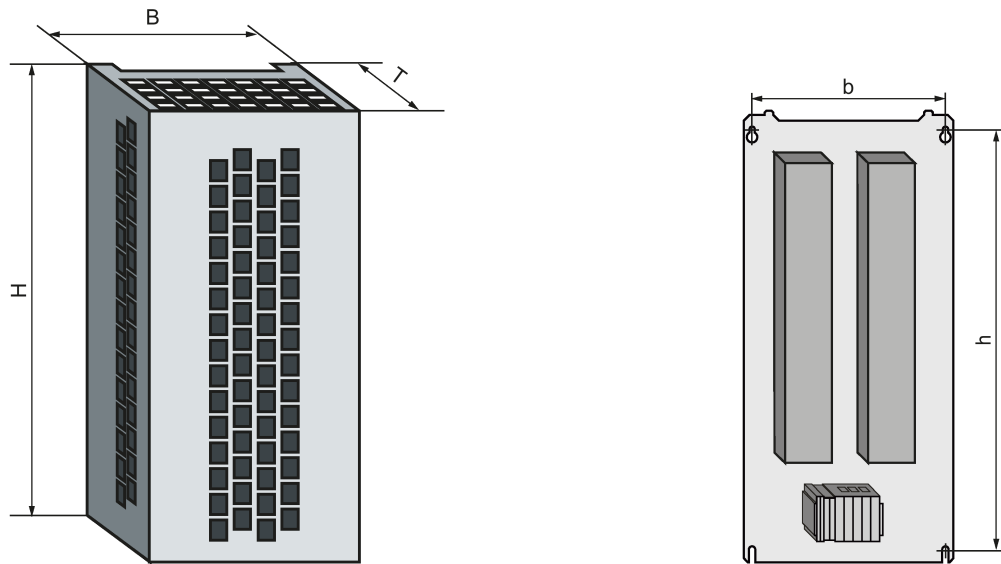

Figure 8-11 Drilling and envelope dimensions

Table 8- 12 Dimensions and weights

Article No.	Overall dimensions (mm)			Drilling dimensions (mm)			Weight (kg)
	W	H	D	b	h	Mounting	
6SE6400-4BD11-0AA0	72	230	43.5	56	220	M4 / 3 Nm	1
6SL3201-0BE12-0AA0	153	329	43.5	139	316	M4 / 3 Nm	2
6SE6400-4BD16-5CA0	150	185	285	134	176	M4 / 3 Nm	3.8
6SE6400-4BD21-2DA0	175	270	515	159	261	M4 / 3 Nm	7.4
6SE6400-4BD22-2EA0	175	270	645	159	261	M4 / 3 Nm	10.6
6SE6400-4BD24-0FA0	315	395	650	299	386	M4 / 3 Nm	16.7
6SE6400-4BD26-0FA0	484	526	301	470	517	M4 / 3 Nm	17.5
6SL3000-1BE32-5AA0	485	1325	810	380	780		120

Use the screws, nuts and washers when mounting the braking resistors.

For the inverters, use the following or comparable braking resistors. The technical properties and statements made by the manufacturer apply.

#### Note

#### Braking resistors for frame sizes FSD ... FSF

Only use braking resistors that are UL approved, and have successfully passed the "Abnormal Operation Test" according to UL 508.

## Technical data and assignment tables

Table 8- 13 Technical data

Article No.	Re- sistance ( $\Omega$ )	Power (kW)		Connection	Degree of protection
		$P_{DB}$ 1)	$P_{max}$ 2)		
6SE6400-4BD11-0AA0	398	0.1	2	Integrated, PE M4	IP20
6SL3201-0BE12-0AA0	160	0.2	4	Integrated, PE M4	IP20
6SE6400-4BD16-5CA0	56	0.65	13	Integrated, PE M5	IP20
6SE6400-4BD21-2DA0	27	1.2	24	6 mm <sup>2</sup> /M6 bolts	IP20
6SE6400-4BD22-2EA0	15	2.2	44	16 mm <sup>2</sup> /M6 bolts	IP20
6SE6400-4BD24-0FA0	8	4	80	35 mm <sup>2</sup> /M6 bolts	IP20
6SE6400-4BD26-0FA0	6	5.6	120	35 mm <sup>2</sup> /M6 bolts	IP20
6SL3000-1BE32-5AA0	2	50	250	70 mm <sup>2</sup> /M10 bolts	IP20

1)  $P_{DB}$ : Rated power

2)  $P_{max}$ : max. permissible power

Table 8- 14 Assignment tables

Article number	Power Module		Frame size
	Article number	Article number	
6SE6400-4BD11-0AA0	6SL3224-0BE13-7UA0 6SL3224-0BE17-5UA0 6SL3224-0BE21-5UA0	6SL3224-0BE15-5UA0 6SL3224-0BE21-1UA0	FSA
6SL3201-0BE12-0AA0	6SL3224-0BE22-2 . A0 6SL3224-0BE24-0 . A0	6SL3224-0BE23-0 . A0	FSB
6SE6400-4BD16-5CA0	6SL3224-0BE25-5 . A0 6SL3224-0BE31-1 . A0	6SL3224-0BE27-5 . A0	FSC
6SE6400-4BD21-2DA0	6SL3224-0BE31-5 . A0 6SL3224-0BE32-2 . A0	6SL3224-0BE31-8 . A0	FSD
6SE6400-4BD22-2EA0	6SL3224-0BE33-0 . A0	6SL3224-0BE33-7 . A0	FSE
6SE6400-4BD24-0FA0	6SL3224-0BE34-5 . A0 6SL3224-0BE37-5 . A0	6SL3224-0BE35-5 . A0	FSF
6SE6400-4BD26-0FA0	6SL3224-0BE38-8UA0	6SL3224-0BE41-1UA0	FSF
6SL3000-1BE32-5AA0	6SL3224-0XE41-3UA0 6SL3224-0XE42-0UA0	6SL3224-0XE41-6UA0	FSGX

### Load cycles for the braking resistors

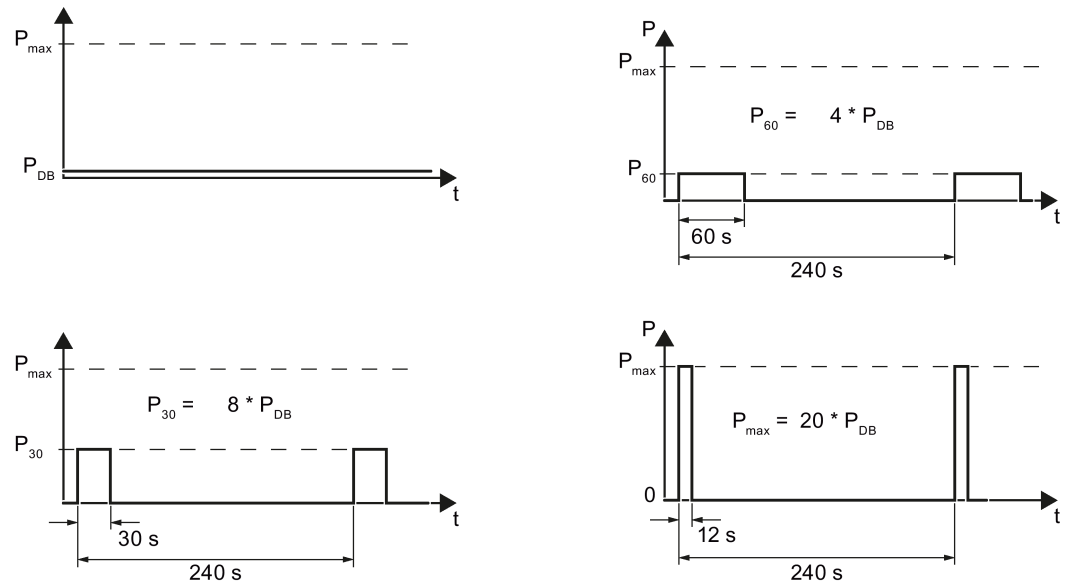

Figure 8-12 Pulse power, rated power and duty cycle examples for the braking resistor

### 8.3.7.1 Connect the temperature contact of the braking resistor

#### Monitoring the temperature of the braking resistor

**Procedure**



1 Proceed as follows to monitor the braking resistor temperature:

1. Connect the temperature monitoring system of the braking resistor (terminals T1 and T2 on the braking resistor) to a free digital input at the Control Unit of the inverter.

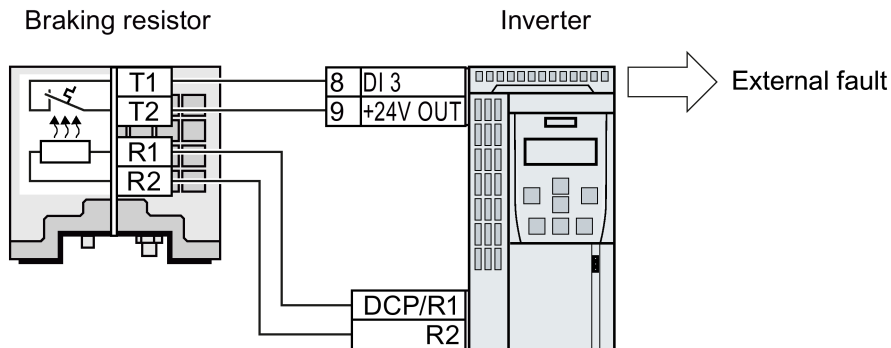

Figure 8-13 Example: Temperature monitoring of the braking resistor via digital input DI 3 on the Control Unit

2. When commissioning the drive, define the function of the digital input used as external fault, using p2106.

As an example with temperature monitoring via digital input DI 3: p2106 = 722.3.



You have ensured that the temperature is monitored.

### 8.3.8 Connecting a motor holding brake to a Safe Brake Relay

The inverter uses the Brake Relay to control the motor holding brake. Two types of Brake Relay exist:

- The Brake Relay controls the motor holding brake
- The Safe Brake Relay controls a 24 V motor holding brake and monitors the brake control for short-circuit or cable breakage.

**Note****Brake Relay and Safe Brake Relay**

The Brake Relay and the Safe Brake Relay do not differ from each other in the installation and the connection to the inverter.

**Connection to the inverter**

To ensure that you have the correct cable for connecting the Brake Relay irrespective of the inverter size, you are supplied with two preassembled cables with different lengths. Connect the appropriate cable to the Brake Module and to the inverter as shown below.

If you are using your own cable, ensure that the cable is insulated and rated for 600 V.

**8.3.8.1 Mounting and connecting the brake relay**

The Brake Relay must be connected to the protective conductor if the motor brake is supplied from a PELV circuit.

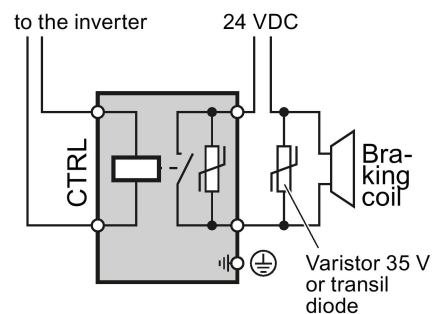
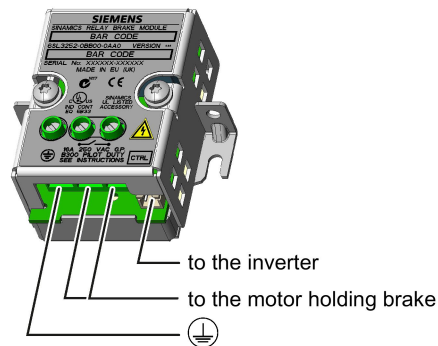
**Connections**

Circuit diagram, 24 V brake

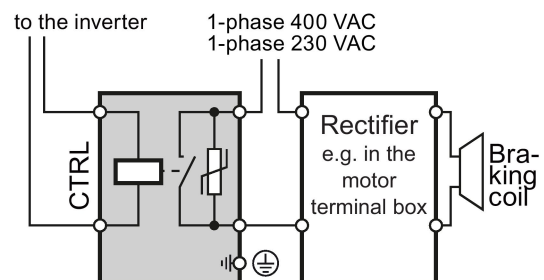

Circuit diagram, 440 V brake

### 8.3.8.2 Mounting and connecting the Safe Brake Relay

The Brake Relay must be connected to the protective conductor if the motor brake is supplied from a PELV circuit.

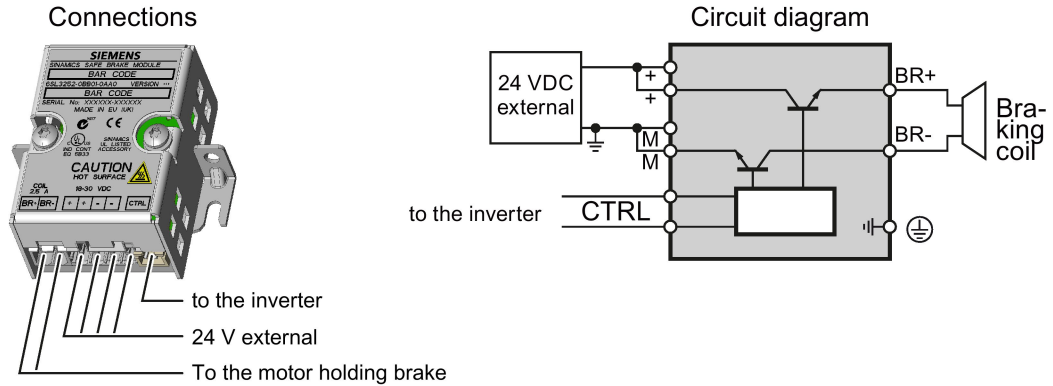

### 8.3.8.3 Technical data of the brake relay?

	<b>Brake Relay</b> <b>6SL3252-0BB00-0AA0</b>	<b>Safe Brake Relay</b> <b>6SL3252-0BB01-0AA0</b>
Input voltage	via the Power Module	20.4 ... 28.8 VDC <sup>1)</sup>
Input current	via the Power Module	Max. 2.5 A
Max. connection cross-section:	2.5 mm <sup>2</sup>	2.5 mm <sup>2</sup>
Degree of protection	IP20	IP20
Switching capability of the NO contact	1-phase 440 VAC, 3.5 A 1-phase 30 VDC, 12 A	-
Output voltage	-	24 V
Output current	-	max. 2 A

<sup>1)</sup> External, controlled power supply required. Recommended voltage: 26 VDC

### 8.3.8.4 Mounting and connecting the brake relay

#### Installing the Brake Relay

If you use the optional shield plate, install the Brake Relay on the shield plate of the Power Module.

If you do not use the shield plate, install the Brake Relay as close as possible to the Power Module.

#### Connecting the Brake Relay to the inverter

The connector for the Brake relay is located at the front of the Power Module for the FSA ... FSC frame sizes. These Power Modules have a cable entry for the connecting cable to the Brake Relay.

The connector for the Brake Relay is located at the bottom of the Power Module for the FSD ... FSF frame sizes.

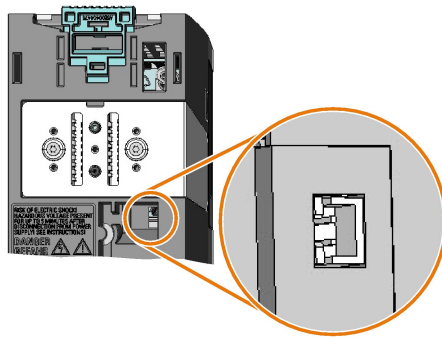

Brake relay connector for FSA ... FSC  
Power Modules

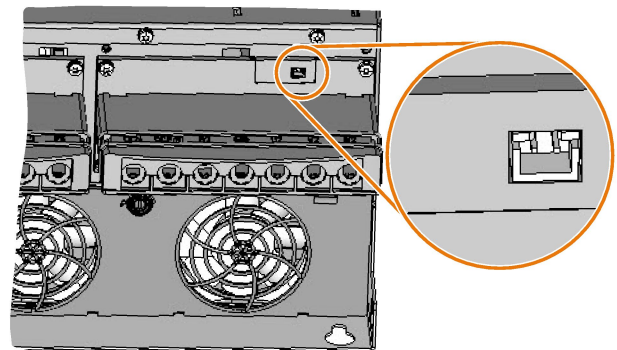

Brake relay connector for FSD ... FSF  
Power Modules

### 8.3.9 For standard rail mounting

With the adapter for DIN mounting rail (**DIN Rail Mounting Kit, DRMK**), without requiring any tools, you can snap the inverter onto the two parallel mounting rails - and easily remove them again using a screwdriver.

Power Modules, frame sizes FSA and FSB, can be mounted on rails.

- Frame size FSA with a base component.
- Frame size FSB without a base component

The adapter has an integrated shield connection plate to connect the motor cable shield.

The installation grid for DIN mounting rails is 115 (± 1) mm.

### Mounting the DIN mounting rail adapter (DRMK)



You can find the mounting instructions for the DIN mounting rail adapter in the Internet at: (<https://support.industry.siemens.com/cs/ww/en/view/23622394>)

### 8.3.10 Shield connection kit

The shield connection kit is used to connect the shield of the control and motor cable in an EMC-compliant fashion.



The instructions for installing the shield connection kit are available in the Internet at (<https://support.industry.siemens.com/cs/ww/de/view/23621093/en>):

#### Article numbers of the shield connection kit for different Power Modules

- FSA: 6SL3262-1AA00-0BA0
- FSB: 6SL3262-1AB00-0DA0
- FSC: 6SL3262-1AC00-0DA0
- FSD: 6SL3262-1AD00-0DA0
- FSE: 6SL3262-1AD00-0DA0
- FSF: 6SL3262-1AF00-0DA0

# Appendix

## A.1 Manuals and technical support

### A.1.1 Overview of the manuals



#### Manuals with additional information that can be downloaded:

- PM240 Power Modules  
<https://support.industry.siemens.com/cs/ww/de/view/52593268/en>  
 Installing Power Modules, reactors and filters. Technical specifications, maintenance (this manual)
- CU230P-2 Compact Operating Instructions  
<https://support.industry.siemens.com/cs/ww/en/view/109477360>  
 Commissioning the inverter
- CU240B/E-2 Compact Operating Instructions  
<https://support.industry.siemens.com/cs/ww/en/view/109477361>  
 Commissioning the inverter.
- Getting Started CU240E  
<https://support.industry.siemens.com/cs/ww/de/view/31657012/en>  
 Commissioning the inverter
- Getting Started CU240S  
<https://support.industry.siemens.com/cs/ww/de/view/31657660/en>  
 Commissioning the inverter
- CU250S-2 Compact Operating Instructions  
<https://support.industry.siemens.com/cs/ww/en/view/99730303>  
 Commissioning the inverter.
- CU230P-2 operating instructions  
<https://support.industry.siemens.com/cs/ww/en/view/109478827>  
 Installing, commissioning and maintaining the inverter. Advanced commissioning

- CU240E / CU240S operating instructions  
(<https://support.industry.siemens.com/cs/ww/de/view/52594818/en>)  
Installing, commissioning and maintaining the inverter. Advanced commissioning  

- CU240B/E-2 operating instructions  
(<https://support.industry.siemens.com/cs/ww/en/view/109478828>)  
Installing, commissioning and maintaining the inverter. Advanced commissioning  

- CU250S-2 operating instructions  
(<https://support.industry.siemens.com/cs/ww/en/view/109478829>)  
Installing, commissioning and maintaining the inverter. Advanced commissioning  

- EMC installation guideline  
(<http://support.automation.siemens.com/WW/view/en/60612658>)  
EMC-compliant control cabinet design, potential equalization and cable routing  

- CU230P-2 List Manual (<https://support.industry.siemens.com/cs/ww/en/view/109477248>)  
Parameter list, alarms and faults. Graphic function diagrams  

- CU240E, CU240S List Manual  
(<https://support.industry.siemens.com/cs/ww/de/view/27864391/en>)  
Parameter list, alarms and faults. Graphic function diagrams  

- CU240B/E-2 List Manual  
(<https://support.industry.siemens.com/cs/ww/en/view/109477251>)  
Parameter list, alarms and faults. Graphic function diagrams  

- CU250S-2 List Manual (<https://support.industry.siemens.com/cs/ww/en/view/109477253>)  
Parameter list, alarms and faults. Graphic function diagrams  

- Power Module Installation Manual  
(<https://support.industry.siemens.com/cs/ww/en/ps/13224/man>)  
Installing Power Modules, reactors and filters. Technical specifications, maintenance  

- Accessories manual (<https://support.industry.siemens.com/cs/ww/en/ps/13225/man>)  
Installation descriptions for inverter components, e.g. line reactors and line filters. The printed installation descriptions are supplied together with the components.  

## A.1.2 Configuring support

### Catalog

Ordering data and technical information for SINAMICS G inverters.



Catalog D31 for download or online catalog (Industry Mall):



All about SINAMICS G120 ([www.siemens.com/sinamics-g120](http://www.siemens.com/sinamics-g120))

### SIZER

The configuration tool for SINAMICS, MICROMASTER and DYNAVERT T drives, motor starters, as well as SINUMERIK, SIMOTION controllers and SIMATIC technology



SIZER on DVD:

Article number: 6SL3070-0AA00-0AG0



Download SIZER (<http://support.automation.siemens.com/WW/view/en/10804987/130000>)

### EMC (electromagnetic compatibility) technical overview

Standards and guidelines, EMC-compliant control cabinet design



EMC overview (<https://support.industry.siemens.com/cs/ww/en/view/103704610>)

### EMC Guidelines configuration manual

EMC-compliant control cabinet design, potential equalization and cable routing



EMC installation guideline (<http://support.automation.siemens.com/WW/view/en/60612658>)

### Safety Integrated for novices technical overview

Application examples for SINAMICS G drives with Safety Integrated



Safety Integrated for novices  
(<https://support.industry.siemens.com/cs/ww/en/view/80561520>)

### A.1.3 Product Support



Additional information about the product and more is available in the Internet: Product support (<http://www.siemens.com/automation/service&support>).

This address provides the following:

- Actual product information (Update), FAQ (frequently asked questions), downloads.
- The Newsletter contains the latest information on the products you use.
- The Knowledge Manager (Intelligent Search) helps you find the documents you need.
- Users and specialists from around the world share their experience and knowledge in the Forum.
- You can find your local representative for Automation & Drives via our contact database under "Contact & Partner".
- Information about local service, repair, spare parts and much more can be found under "Services".

## A.2 Disposal

Protecting the environment and preserving its resources are corporate goals of the highest priority for Siemens. Our worldwide environmental management system according to ISO 14001 ensures compliance with legislation and sets high standards in this regard. Environmentally friendly design, technical safety and health protection are always firm goals, even at the product development stage.

Recommendations for the environmentally friendly disposal of the machine and its components are given in the following chapter.

- Be sure to comply with local disposal regulations.
- Separate the housing parts according to their material.
- Dispose of the parts in accordance with the applicable legal regulations.
- Dispose of the packaging material in accordance with the applicable legal regulations.

### Components

- Sort the components for recycling according to whether they are:
  - Electronic waste
  - Scrap iron, e.g. shield plates
  - Aluminum
  - Insulating materials and plastics

## A.3 Directives and standards

### Relevant directives and standards

The following directives and standards are relevant for the inverters:



#### European Low Voltage Directive

The inverters fulfil the requirements stipulated in the Low-Voltage Directive 2014/35/EU, if they are covered by the application area of this directive.

#### European Machinery Directive

The inverters fulfil the requirements stipulated in the Machinery Directive 2006/42/EU, if they are covered by the application area of this directive.

However, the use of the inverters in a typical machine application has been fully assessed for compliance with the main regulations in this directive concerning health and safety.

#### European EMC Directive

By completely complying with IEC/EN 61800-3, it has been proven that the inverter is in compliance with directive 2004/108/EC or 2014/30/EU.



#### Underwriters Laboratories (North American market)

Inverters provided with one of the test symbols displayed fulfil the requirements stipulated for the North American market as a component of drive applications.



#### EMC requirements for South Korea

The inverters with the KC marking on the rating plate satisfy the EMC requirements for South Korea.



#### Eurasian conformity

The inverters comply with the requirements of the Russia/Belarus/Kazakhstan customs union (EAC).



#### Australia and New Zealand (RCM formerly C-Tick)

The inverters showing the test symbols fulfil the EMC requirements for Australia and New Zealand.

### Specification for semiconductor process equipment voltage drop immunity

The inverters comply with the requirements of standard SEMI F47-0706.

### Quality systems

Siemens AG employs a quality management system that meets the requirements of ISO 9001 and ISO 14001.

## Certificates for download



You can find the EC declaration of conformity in the Internet at:

Declaration of conformity (<https://support.industry.siemens.com/cs/ww/en/view/58275445>)

Certificates for the relevant directives, prototype test certificates, manufacturers declarations and test certificates for functions relating to functional safety ("Safety Integrated") are available on the Internet at the following address.

Certificates (<http://support.automation.siemens.com/WW/view/en/22339653/134200>)

You can find UL certificates on the Internet:

Products with UL certificate (<http://database.ul.com/cgi-bin/XYV/template/LISEXT/1FRAME/index.html>)

You can find TÜV SÜD certificates on the Internet:

Products with TÜV SÜD certificate ([https://www.tuev-sued.de/industry\\_and\\_consumer\\_products/certificates](https://www.tuev-sued.de/industry_and_consumer_products/certificates))

## Standards that are not relevant



### China Compulsory Certification

The inverters do not fall in the area of validity of the China Compulsory Certification (CCC).

## A.4 Abbreviations

<b>Abbreviation</b>	<b>State</b>
AC	Alternating current
CE	Communauté Européenne
CU	Control Unit
DC	Direct current
DI	Digital input
DIP	DIP switch
DO	Digital output
ECD	Equivalent circuit diagram
EEC	European Economic Community
ELCB	Earth leakage circuit breaker
EMC	Electromagnetic compatibility (EMC)
EMI	Electromagnetic interference
FS...	Frame size ...
GSG	Getting Started Guide
HO	High overload
I/O	Input/Output
IGBT	Insulated gate bipolar transistor
LED	Light emitting diode
LO	Low overload
NC	NC contact
NEMA	National Electrical Manufacturers Association
NO	NO contact
OPI	Operating instructions
PELV	Protective extra low voltage
PM	Power Module
PPE	Personnel protective equipment
PT	Push-through technology
RCCB	Residual-current operated circuit breaker
RCD	Residual current device
RFI	Radio frequency interference
SELV	Safety extra-low voltage
VT	Variable torque



# Index

## 8

87 Hz characteristic, 50, 50

## A

Adapter for mounting on DIN rails, 108

Air barrier, 28

## B

Base components, 82

Base load, 63

Base load input current, 63

Base load output current, 63

Base load power, 63

Brake Relay, 104

Braking resistor

Clearances, 100

Dimension drawings, 101

Installation, 100

## C

Cable lug, 48, 48

ring-shaped, 48

Standard, 48, 48

Catalog, 111

Category C2, 44

Category C3, 44

Clearances, 100

Commutation dips, 84

Configuring support, 111

Control Units for the PM240 Power Modules, 19

Cooling, 28

## D

Delta connection, 50

Derating

Installation altitude, 73

Dimension drawings, 85, 91, 101

Disposal, 112

Drilling pattern, 85, 91, 101

## E

Electrical installation, 35

EMC, 22, 22

## F

Field weakening, 50

Function Manual, 109

## G

Getting Started, 109

## H

Hardware Installation Manual, 109

Harmonic currents, 79

Harmonics, 84

High Overload, 64

Hotline, 112

## I

Industry Mall, 111

Installation altitude, 73

Installing, 30

IP21 degree of protection, 21

IT system, 38

## L

Line and motor connection, frame sizes

FSD ... FSF, 47

Line and motor connections, frame sizes FSD ...

FSF, 48

Line reactor

Dimension drawings, 85, 91

Line supply type, 38

List Manual, 109

Low Overload, 64

## **M**

### Maintenance

- Cleaning, 52
- Dirt, 52
- Pollution, 52
- Terminals, 52
- Ventilation, 52

## **N**

- Neutral conductor, 38

## **O**

- Operating Instructions, 109
- Overvoltage protection, 84

## **P**

- Power distribution systems, 38
- Power range of the motors, 19
- Protective conductor, 38

## **Q**

- Questions, 112

## **R**

- Radio interference class, 88

## **S**

- Safe Brake Relay, 104
- Safety notes
  - Electrical installation, 35
- Service life of the fan, 54
- Sine-wave filter, 94
- SIZER, 111
- Standards
  - EN 61800-3, 113
- Star connection (Y), 50
- Support, 112

## **T**

- TN line system, 38
- TT line system, 38



## Further information

SINAMICS inverters:  
[www.siemens.com/sinamics](http://www.siemens.com/sinamics)

Siemens AG  
Digital Factory  
Motion Control  
Frauenauracher Str. 80  
DE-91056 Erlangen

Subject to change without prior notice  
© Siemens AG 2009 - 2017

For further  
information about  
SINAMICS G120,  
scan the QR code.



[www.siemens.com/drives](http://www.siemens.com/drives)