

SINAMICS G110 standard inverters

0.12 kW to 3 kW (0.16 hp to 4 hp)

Controlled Power Modules

Overview



SINAMICS G110, frame size FSA (right with flat heat sink)



SINAMICS G110, frame sizes FSB and FSC

SINAMICS G110 is an inverter with basic functions for a wide range of industrial drive applications with variable speeds.

The extremely compact SINAMICS G110 inverter operates with voltage-frequency control from 200 V to 240 V on single-phase line supply systems.

It is the ideal "price-conscious" inverter solution in the lower power range of the SINAMICS product family.

The following **line-side power components** are available for SINAMICS G110 inverters:

- EMC filters
- Line reactors
- Fuses
- Circuit breakers

The **accessories** listed below are also available:

- Operator panel
- Mounting accessories
- Commissioning tool

The latest technical documentation (catalogs, dimension drawings, certificates, manuals and operating instructions), are available on the Internet at the following address:

www.siemens.com/sinamics-g110/documentation

and offline on the DVD-ROM CA 01 in the DT Configurator. In addition, the DT Configurator can be used in the Internet without requiring any installation. The Drive Technology Configurator (DT Configurator) can be found in the Siemens Industry Mall at the following address:

www.siemens.com/dt-configurator

Benefits

- Simple installation, configuration, and commissioning
- Robust EMC design
- Extensive parameter range enables configurations for a wide range of applications
- Simple cable connection
- Scalable functionality with analog and USS versions
- Quiet motor operation as a result of the high pulse frequency
- Status information and alarms via the optional BOP (Basic Operator Panel)
- Rapid copying of parameters via the optional BOP
- External options for PC communication and BOP
- Fast response time of the digital inputs with a high degree of reproducibility for applications demanding fast responses
- Precise setpoint input using a high-resolution 10-bit analog input (analog versions only)
- LED for status information
- Variants with integrated EMC filter class A or B
- DIP switches for easy adaptation to 50 Hz or 60 Hz applications
- DIP switches for simple bus termination for the USS version (RS485)
- Bus-capable serial RS485 interface (USS versions only) enables integration into a networked drive system
- 2/3-wire method (pulsed/maintained signals) for universal control via digital inputs
- Adjustable lower voltage limit for the DC link to ensure controlled motor braking if the power fails

Accessories (overview)

- BOP operator panel
- Adapter for mounting on DIN rails (frame sizes FSA and FSB)
- PC inverter connection kit
- STARTER commissioning tool

Line-side power components (overview)

- EMC filter, class B with low leakage currents (additionally available for inverters with integrated filter)
- EMC filter, class B (additionally available for inverters with integrated filter)
- Line reactors

International standards

- Fulfills the requirements of the EU low-voltage guideline
- CE marking
- Certified to UL and cUL
- C-Tick

SINAMICS G110 standard inverters

0.12 kW to 3 kW (0.16 hp to 4 hp)

Controlled Power Modules

Design

The SINAMICS G110 standard inverters are equipped with a control module and a power module, providing the inverter in the CPM 110 version (Controlled Power Module) with a compact and efficient design. They operate with the latest IGBT technology and digital microprocessor control.

The SINAMICS G110 inverter product range consists of the following variants and versions:

- The **analog variant** is available in the following versions:
 - Without EMC filter, with heat sink
 - With integrated EMC filter, class A/B, with heat sink
 - Without EMC filter, with flat heat sink (FSA frame size only)
 - With integrated EMC filter, class B, with flat heat sink (FSA frame size only)
- The **USS variant** (RS485) is available in the following versions:
 - Without EMC filter, with heat sink
 - With integrated EMC filter, class A/B, with heat sink
 - Without EMC filter, with flat heat sink (FSA frame size only)
 - With integrated EMC filter, class B, with flat heat sink (FSA frame size only)

For frame size FSA, cooling is achieved through a heat sink and natural convection. Frame size FSA with flat heat sink offers space-saving and favorable heat dissipation since an additional heat sink can be installed outside the control cabinet. For frame sizes FSB and FSC, an integrated fan is used to cool the heat sink, making the compact design possible.

The connections for all inverter variants are easily accessible and in the same location. To ensure optimum electromagnetic compatibility and easy connection, the line and motor connections are located on opposite sides (as with contactors). The control terminal block does not require screws to install it.

The optional BOP (Basic Operator Panel) can be installed without the use of tools.

Function

- The stress on the machine mechanical system is reduced by using a skippable frequency range to avoid resonance effects, selecting ramp-up/ramp-down times up to 650 s, using ramp smoothing as well as being able to switch the inverter to a spinning motor (flying restart circuit)
- Increased plant availability as a result of automatic restarting following a power failure or stoppage
- Fast current limiting (FCL) for fault-free operation in the event of sudden load surges
- Parameterizable V/f characteristic (e.g. for synchronous motors)
- DC braking as well as compound braking for fast braking without an external braking resistor
- DC link voltage limiting using V_{DCmax} controller
- Slip compensation, electronic motorized potentiometer function and three fixed speed setpoints
- Parameterizable voltage boost for a higher dynamic performance when starting and accelerating
- Motor holding brake function to control an external mechanical brake

SINAMICS G110 standard inverters

0.12 kW to 3 kW (0.16 hp to 4 hp)

Controlled Power Modules

Selection and ordering data

Referring to the rated output current, most 2-pole to 6-pole low-voltage motors are being supported, e.g. the motor series 1LE1. The rated power represents a benchmark only. For a

description of the overload performance, please refer to the general technical specifications of the Controlled Power Modules.

Power		Rated input current (at 230 V) A	Rated output current A	Frame size	Version	SINAMICS G110 without filter	SINAMICS G110 with integrated filter	Filter class ¹⁾ With use of shielded cables with a max. cable length of		
kW	hp					Article No.	Article No.	5 m (16 ft)	10 m (33 ft)	25 m (82 ft)
0.12	0.16	2.3	0.9	FSA	Analog	6SL3211-0AB11-2UA1	6SL3211-0AB11-2BA1	B	A ²⁾	2)
					USS	6SL3211-0AB11-2UB1	6SL3211-0AB11-2BB1	B	A ²⁾	2)
					Analog (with flat heat sink)	6SL3211-0KB11-2UA1	6SL3211-0KB11-2BA1	B	A ²⁾	2)
					USS (with flat heat sink)	6SL3211-0KB11-2UB1	6SL3211-0KB11-2BB1	B	A ²⁾	2)
0.25	0.33	4.5	1.7	FSA	Analog	6SL3211-0AB12-5UA1	6SL3211-0AB12-5BA1	B	A ²⁾	2)
					USS	6SL3211-0AB12-5UB1	6SL3211-0AB12-5BB1	B	A ²⁾	2)
					Analog (with flat heat sink)	6SL3211-0KB12-5UA1	6SL3211-0KB12-5BA1	B	A ²⁾	2)
					USS (with flat heat sink)	6SL3211-0KB12-5UB1	6SL3211-0KB12-5BB1	B	A ²⁾	2)
0.37	0.5	6.2	2.3	FSA	Analog	6SL3211-0AB13-7UA1	6SL3211-0AB13-7BA1	B	A ²⁾	2)
					USS	6SL3211-0AB13-7UB1	6SL3211-0AB13-7BB1	B	A ²⁾	2)
					Analog (with flat heat sink)	6SL3211-0KB13-7UA1	6SL3211-0KB13-7BA1	B	A ²⁾	2)
					USS (with flat heat sink)	6SL3211-0KB13-7UB1	6SL3211-0KB13-7BB1	B	A ²⁾	2)
0.55	0.75	7.7	3.2	FSA	Analog	6SL3211-0AB15-5UA1	6SL3211-0AB15-5BA1	B	A ²⁾	2)
					USS	6SL3211-0AB15-5UB1	6SL3211-0AB15-5BB1	B	A ²⁾	2)
					Analog (with flat heat sink)	6SL3211-0KB15-5UA1	6SL3211-0KB15-5BA1	B	A ²⁾	2)
					USS (with flat heat sink)	6SL3211-0KB15-5UB1	6SL3211-0KB15-5BB1	B	A ²⁾	2)
0.75	1	10	3.9 (at 40 °C (104 °F))	FSA	Analog	6SL3211-0AB17-5UA1	6SL3211-0AB17-5BA1	B	A ²⁾	2)
					USS	6SL3211-0AB17-5UB1	6SL3211-0AB17-5BB1	B	A ²⁾	2)
					Analog (with flat heat sink)	6SL3211-0KB17-5UA1	6SL3211-0KB17-5BA1	B	A ²⁾	2)
					USS (with flat heat sink)	6SL3211-0KB17-5UB1	6SL3211-0KB17-5BB1	B	A ²⁾	2)
1.1	1.5	14.7	6	FSB	Analog	6SL3211-0AB21-1UA1	6SL3211-0AB21-1AA1	B	A ²⁾	A ²⁾
					USS	6SL3211-0AB21-1UB1	6SL3211-0AB21-1AB1	B	A ²⁾	A ²⁾
1.5	2	19.7	7.8 (at 40 °C (104 °F))	FSB	Analog	6SL3211-0AB21-5UA1	6SL3211-0AB21-5AA1	B	A ²⁾	A ²⁾
					USS	6SL3211-0AB21-5UB1	6SL3211-0AB21-5AB1	B	A ²⁾	A ²⁾
2.2	3	27.2	11	FSC	Analog	6SL3211-0AB22-2UA1	6SL3211-0AB22-2AA1	B	A ²⁾	A ²⁾
					USS	6SL3211-0AB22-2UB1	6SL3211-0AB22-2AB1	B	A ²⁾	A ²⁾
3	4	35.6	13.6 (at 40 °C (104 °F))	FSC	Analog	6SL3211-0AB23-0UA1	6SL3211-0AB23-0AA1	B	A ²⁾	A ²⁾
					USS	6SL3211-0AB23-0UB1	6SL3211-0AB23-0AB1	B	A ²⁾	A ²⁾

The current data apply to an ambient temperature of 50 °C (122 °F) unless specified otherwise.

The last digit of the complete article number for the SINAMICS G110 inverters represents the release version. When ordering, a different digit from the one specified may be provided due to technical updates.

All SINAMICS G110 inverters are supplied without an operator panel (BOP). A BOP or other accessories must be ordered separately.

¹⁾ The filter class **in bold** is stamped on the inverter rating plate.

²⁾ With additional filter (also class B).

SINAMICS G110 standard inverters

0.12 kW to 3 kW (0.16 hp to 4 hp)

Controlled Power Modules

Technical specifications

	Controlled Power Modules
Power range	0.12 ... 3 kW (0.16 ... 4 hp)
Line voltage	200 ... 240 V \pm 10 % 1 AC
Line frequency	47 ... 63 Hz
Output frequency	0 ... 650 Hz (a 550 Hz limit is in preparation in order to satisfy legal requirements)
Output voltage	200 ... 240 V 3 AC
Offset factor $\cos \varphi$	\geq 0.95
Inverter efficiency	
• For devices < 0.75 kW	90 ... 94 %
• For devices \geq 0.75 kW	\geq 95 %
Overload capability	Overload current 1.5 x rated output current (i.e. 150 % overload) for 60 s, then 0.85 x rated output current for 240 s, cycle time 300 s
Inrush current	Not higher than the rated input current
Control methods	Linear V/f characteristic (with parameterizable voltage boost); square V/f characteristic; multipoint characteristic (parameterizable V/f characteristic)
Pulse frequency	8 kHz (standard) 2 ... 16 kHz (in 2 kHz increments)
Fixed frequencies	3, programmable
Skippable frequency range	1, programmable
Setpoint resolution	0.01 Hz digital 0.01 Hz serial 10 bit analog (motorized potentiometer 0.1 Hz)
Digital inputs	3 programmable digital inputs, non-floating; PNP type, SIMATIC-compatible
Analog input (analog variant)	1, for setpoint (0 ... 10 V, scaleable or for use as 4th digital input)
Digital output	1 isolated optocoupler output (24 V DC, 50 mA, ohmic, NPN type)
Universal serial interface (USS variant)	RS485, for operation with USS protocol
Motor cable length, max.	
• Shielded	25 m (82 ft)
• Unshielded	50 m (164 ft)
Electromagnetic compatibility	All devices with integrated EMC filter for drive systems in category C2 installations (limit value in accordance with EN 55011, class A, group 1) and category C3 installations (limit value in accordance with EN 55011, class A, group 2). All devices with an integrated EMC filter and shielded cables with a maximum length of 5 m (16 ft) also fulfill the limit values of EN 55011, class B for conducted interference.
Braking	DC injection braking, compound braking
Degree of protection	IP20
Operating temperature	-10 ... +40 °C (14 °F ... 104 °F) up to +50 °C (122 °F) with derating
Storage temperature	-40 ... +70 °C (-40 °F ... +158 °F)
Relative humidity	95 % (non-condensing)
Installation altitude	Up to 1000 m (3281 ft) above sea level without derating <ul style="list-style-type: none"> • Rated output current <ul style="list-style-type: none"> at 4000 m (13124 ft) above sea level: 90 % • Line voltage <ul style="list-style-type: none"> up to 2000 m (6562 ft) above sea level: 100 % at 4000 m (13124 ft) above sea level: 75 %
SCCR (Short Circuit Current Rating) according to UL ¹⁾	10 kA (up to maximum 100 kA)
Protection features for	<ul style="list-style-type: none"> • Undervoltage • Overvoltage • Ground fault • Short-circuit • Stall protection • Thermal motor protection I^2t • Inverter overtemperature • Motor overtemperature
Compliance with standards	UL, cUL, CE, C-Tick
CE marking, according to	Low-Voltage Directive 2006/95/EC

¹⁾ Applies to industrial control panel installations to NEC article 409 or UL 508A.

SINAMICS G110 standard inverters

0.12 kW to 3 kW (0.16 hp to 4 hp)

Controlled Power Modules

Technical specifications

		Controlled Power Modules						
		FSA ≤ 0.37 kW (0.5 hp)	FSA 0.55 kW (0.75 hp) and 0.75 kW (1 hp)	FSA ≤ 0.37 kW (0.5 hp) with flat heat sink	FSA 0.55 kW (0.75 hp) and 0.75 kW (1 hp) with flat heat sink	FSB 1.1 kW (1.5 hp) and 1.5 kW (2 hp)	FSC 2.2 kW (3 hp)	FSC 3 kW (4 hp)
Dimensions (without accessories)								
• Width	mm (in)	90 (3.54)	90 (3.54)	90 (3.54)	90 (3.54)	140 (5.51)	184 (7.24)	184 (7.24)
• Height	mm (in)	150 (5.91)	150 (5.91)	150 (5.91)	150 (5.91)	160 (6.30)	181 (7.13)	181 (7.13)
• Depth	mm (in)	116 (4.57)	131 (5.16)	101 (3.98)	101 (3.98)	142 (5.59)	152 (5.98)	152 (5.98)
Weight, approx.								
• Without filter	kg (lb)	0.7 (1.54)	0.8 (1.76)	0.6 (1.32)	0.7 (1.54)	1.4 (3.09)	1.9 (4.19)	2 (4.41)
• With filter	kg (lb)	0.8 (1.76)	0.9 (1.98)	0.7 (1.54)	0.8 (1.76)	1.5 (3.31)	2.1 (4.63)	2.2 (4.85)

Technical specifications for variant with flat heat sink

The design with flat heat sink offers space-saving and improved heat dissipation using an external heat sink.

		Controlled Power Modules frame size FSA with flat heat sink				
		0.12 kW (0.16 hp)	0.25 kW (0.33 hp)	0.37 kW (0.5 hp)	0.55 kW (0.75 hp)	0.75 kW (1 hp)
Operating temperature	°C (°F)	-10 ... +50 (+14 ... +122)	-10 ... +50 (+14 ... +122)	-10 ... +50 (+14 ... +122)	-10 ... +50 (+14 ... +122)	-10 ... +40 (+14 ... +104)
Total power losses at full load and maximum operating temperature as specified	W	22	28	36	43	54
Line-side and control electronics losses	W	9	10	12	13	15
Recommended thermal resistance of heat sink	K/W	3	2.2	1.6	1.2	1.2
Recommended output current	A	0.9	1.7	2.3	3.2	3.9

Derating data and power loss

Pulse frequency

Power		Power loss W	Rated output current in A for a pulse frequency of							
kW	hp		2 kHz	4 kHz	6 kHz	8 kHz	10 kHz	12 kHz	14 kHz	16 kHz
0.12	0.16	22	0.9	0.9	0.9	0.9	0.9	0.9	0.9	0.9
0.25	0.33	28	1.7	1.7	1.7	1.7	1.7	1.7	1.7	1.7
0.37	0.5	36	2.3	2.3	2.3	2.3	2.3	2.3	2.3	2.3
0.55	0.75	43	3.2	3.2	3.2	3.2	3	2.7	2.5	2.2
0.75 (at 40 °C)	1 (at 104 °F)	54	3.9	3.9	3.9	3.9	3.6	3.3	3	2.7
0.75	1	54	3.2	3.2	3.2	3.2	3	2.7	2.5	2.2
1.1	1.5	86	6	6	6	6	5.9	5.7	5.6	5.4
1.5 (at 40 °C)	2 (at 104 °F)	118	7.8	7.8	7.8	7.8	7.6	7.4	7.2	7
1.5	2	118	6	6	6	6	5.9	5.7	5.6	5.4
2.2	3	174	11	11	11	11	10.8	10.5	10.2	9.9
3 (at 40 °C)	4 (at 104 °C)	210	13.6	13.6	13.6	13.6	13.3	12.9	12.6	12.3
3	4	210	11	11	11	11	10.8	10.5	10.2	9.9

The current data apply to an ambient temperature of 50 °C (122 °F) unless specified otherwise.

SINAMICS G110 standard inverters

0.12 kW to 3 kW (0.16 hp to 4 hp)

Controlled Power Modules

Technical specifications

Compliance with standards

CE marking



The SINAMICS G110 inverters meet the requirements of the Low-Voltage Directive 2006/95/EC.

Low-Voltage Directive

The inverters comply with the following standards listed in the official journal of the EU:

- EN 60204
Safety of machinery, electrical equipment of machines
- EN 61800-5-1
Electrical power drive systems with variable speed – Part 5-1: Requirements regarding safety – electrical, thermal, and energy requirements

UL listing



Inverter devices in UL category NMMS certified to UL and cUL, in compliance with UL 508C. UL list number E121068.

For use in environments with pollution degree 2.

See also www.ul.com

Machinery Directive

The inverters are suitable for installation in machines. Compliance with the Machinery Directive 2006/42/EC requires a separate certificate of conformity. This must be provided by the plant construction company or the organization marketing the machine.

EMC Directive

- EN 61800-3
Variable-speed electric drives
Part 3: EMC product standard including specific test methods

The EMC product standard EN 61800-3 for electric drive systems has been valid since July 1, 2005. The transition period for the predecessor standard EN 61800-3/A11 dated February 2001 ended on October 1, 2007. The following information applies to Siemens SINAMICS G110 inverters:

- The EMC product standard EN 61800-3 does not apply directly to a frequency inverter but to a PDS (Power Drive System), which comprises the complete circuitry, motor and cables in addition to the inverter.
- Frequency inverters are normally only supplied to experts for installation in machines or systems. A frequency inverter must, therefore, only be considered as a component which, on its own, is not subject to the EMC product standard EN 61800-3. The inverter's operating instructions, however, specifies the conditions regarding compliance with the product standard if the frequency inverter is expanded to a PDS. For a PDS, the EMC Directive in the EU is complied with by observing the product standard EN 61800-3 for variable-speed electric drive systems. The frequency inverters on their own do not generally require identification according to the EMC Directive.

- In the Standard EN 61800-3 of July 2005, a distinction is no longer made between "general availability" and "restricted availability". Instead, different categories C1 to C4 have been defined in accordance with the environment of the PDS at the operating location:
 - **Category C1:** Drive systems for rated voltages < 1000 V for use in the first environment
 - **Category C2:** Stationary drive systems not connected by means of a plug connector for rated voltages < 1000 V. When used in the first environment, the system must be installed and commissioned by personnel familiar with EMC requirements. A warning note is required.
 - **Category C3:** Drive systems for rated voltages < 1000 V for exclusive use in the second environment. A warning note is required.
 - **Category C4:** Drive systems for rated voltages ≥ 1000 V or for rated currents ≥ 400 A or for use in complex systems in the second environment. An EMC plan must be created.
- The EMC product standard EN 61800-3 also defines limit values for conducted interference and radiated interference for the "second environment" (= industrial power supply systems that do not supply households). These limit values are below the limit values of filter class A to EN 55011. Unfiltered inverters can be used in industrial environments as long as they are part of a system that contains line filters on the higher-level infeed side.
- With SINAMICS G110, Power Drive Systems (PDS) that fulfill the EMC product standard EN 61800-3 can be configured when observing the installation instructions in the product documentation. The table "Overview of SINAMICS G110 components and PDS categories" and the SINAMICS G110 ordering documentation show which of the components can be installed directly in a PDS.
- A differentiation must be made between the product standards for electrical drive systems (PDS) of the range of standards EN 61800 (of which Part 3 covers EMC topics) and the product standards for the devices/systems/machines, etc. This will probably not result in any changes in the practical use of frequency inverters. Since frequency inverters are always part of a PDS and these are part of a machine, the machine manufacturer must observe various standards depending on their type and environment (e.g. EN 61000-3-2 for line harmonics and EN 55011 for radio interference). The product standard for PDS on its own is, therefore, either insufficient or irrelevant.
- With respect to the compliance with limits for line supply harmonics, the EMC product standard EN 61800-3 for PDS refers to compliance with the EN 61000-3-2 and EN 61000-3-12 standards.
- Regardless of the configuration with SINAMICS G110 and its components, the machine construction company (OEM) can also apply other measures to ensure that the machine complies with the EU EMC Directive. The EU EMC Directive is generally fulfilled when the relevant EMC product standards are observed. If they are not available, the generic standards (e.g. DIN EN 61000-x-x) can be used instead. It is important that the conducted and emitted interference at the line connection point and outside the machine remain below the relevant limit values. Any suitable measures can be applied to ensure this.

SINAMICS G110 standard inverters

0.12 kW to 3 kW (0.16 hp to 4 hp)

Controlled Power Modules

Technical specifications

Overview of SINAMICS G110 components and PDS categories

Environment 1 (Residential, commercial)	Category C1 Unfiltered devices and external filter class B with low leakage currents (shielded motor cable up to 5 m (16.41 ft))	Environment 2 (Industry)
	Category C2 All devices with integrated filter (shielded motor cable up to 5 m (16.41 ft)) <u>or</u> All devices with integrated filter (frame size FSA: up to 10 m (32.81 ft); Frame sizes FSB and FSC: shielded motor cable up to 25 m (82.03 ft)) + warning <u>or</u> All devices with integrated filter plus external filter, class B (shielded motor cable up to 25 m (82.03 ft))	Category C2 All devices with integrated filter (shielded motor cable up to 5 m (16.41 ft)) <u>or</u> All devices with integrated filter (frame size FSA: up to 10 m (32.81 ft); Frame sizes FSB and FSC: shielded motor cable up to 25 m (82.03 ft)) <u>or</u> All devices with integrated filter plus external filter, class B (shielded motor cable up to 25 m (82.03 ft)) Note: When devices with an integrated filter and a max. motor cable length of 5 m (16.41 ft) or external class B filters are used, this exceeds the requirements of EN 61800-3 by a considerable margin!
	Category C3 All devices with integrated filter (frame size FSA: up to 10 m (32.81 ft); frame sizes FSB and FSC: shielded motor cable up to 25 m (82.03 ft)) <u>or</u> All devices with integrated filter plus external filter, class B (shielded motor cable up to 25 m (82.03 ft)) A warning note is required. Note: When devices with an integrated filter and external class B filters are used, this exceeds the requirements of EN 61800-3 by a considerable margin!	
	Category C4 Does not apply to SINAMICS G110	

Electromagnetic compatibility

Observing the installation guidelines specific to the product will ensure electromagnetic compliance.

The table below lists the measured results for emissions of and immunity to interference for the SINAMICS G110 inverters.

The inverters were installed according to the guidelines with shielded motor cables and shielded control cables.

EMC phenomenon Standard/test	Relevant criteria	Limit value
Noise emissions EN 61800-3 (environment 1)	Conducted via mains cable	150 kHz ... 30 MHz Unfiltered devices: not tested All devices with integrated/external filter: Depending on the filter type and intended PDS installation: Category C1: The limit value corresponds to EN 55011, class B. Category C2: The limit value corresponds to EN 55011, class A, group 1 Further, all drive units with an integrated/external filter fulfill the limit value for category C3 installations. The limit value corresponds to EN 55011, class A, group 2.
	Emitted by the drive	30 MHz ... 1 GHz All devices The limit value corresponds to EN 55011, class A, group 1
ESD immunity EN 61000-4-2	ESD by air discharge	Test level 3 8 kV
	ESD by contact discharge	Test level 3 6 kV
Electrical fields immunity EN 61000-4-3	Electrical field applied to unit	Test level 3 80 MHz ... 1 GHz 10 V/m
Burst interference immunity EN 61000-4-4	Applied to all cable terminations	Test level 4 4 kV
Surge immunity EN 61000-4-5	Applied to mains cables	Test level 3 2 kV
Immunity to RFI emissions, conducted EN 61000-4-6	Applied to mains, motor and control cables	Test level 3 0,15 MHz ... 80 MHz 80 % AM (1 kHz) 10 V

SINAMICS G110 standard inverters

0.12 kW to 3 kW (0.16 hp to 4 hp)

Controlled Power Modules

Accessories

Basic Operator Panel (BOP)



The BOP can be used to make individual parameter settings.

Values and units are displayed via a 5-digit display.

One BOP can be used for several inverters. It is plugged directly into the inverter.

The BOP provides a function for time-saving copying of parameters. A parameter set of one inverter can be saved and then loaded to another inverter.

PC inverter connection kit

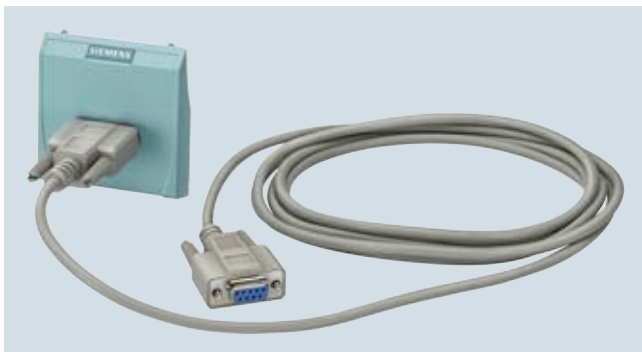

For controlling and commissioning an inverter directly from a PC if the appropriate software (STARTER commissioning tool¹⁾) has been installed.

Isolated RS232 adapter module for a reliable point-to-point connection to a PC.

The scope of supply includes a 9-pin Sub-D connector and an RS232 standard cable (3 m (9.84 ft)).

STARTER commissioning tool

STARTER is a commissioning tool with a graphical interface for commissioning SINAMICS G110 frequency inverters. The software runs under Windows NT/2000/XP Professional and Windows 7. Parameter lists can be read out, changed, stored, read in and printed out.

Selection and ordering data

Accessories

The options listed here are suitable for all SINAMICS G110 inverters.

Description	Article No.
BOP operator panel (Basic Operator Panel)	6SL3255-0AA00-4BA1
PC inverter connection kit including 9-pin SUB-D connector and RS232 standard cable (3 m (9.84 ft))	6SL3255-0AA00-2AA1
Adapter for mounting on DIN rails	
• Size 1 (frame size FSA)	6SL3261-1BA00-0AA0
• Size 2 (frame size FSB)	6SL3261-1BB00-0AA0
SINAMICS Manual Collection on DVD-ROM, multilingual All manuals for low-voltage motors, geared motors and low-voltage inverters	6SL3097-4CA00-0YG2
STARTER commissioning tool¹⁾ on DVD-ROM	6SL3072-0AA00-0AG0

Documentation

A Getting Started Guide is supplied in hard copy for the Controlled Power Modules. The operating instructions and parameter list can be downloaded free of charge from the Internet at:

<http://support.automation.siemens.com/WW/view/en/13740464/133300>

¹⁾ STARTER commissioning tool is also available on the Internet at
<http://support.automation.siemens.com/WW/view/en/10804985/133100>

SINAMICS G110 standard inverters

0.12 kW to 3 kW (0.16 hp to 4 hp)

Controlled Power Modules

3

Dimensional drawings

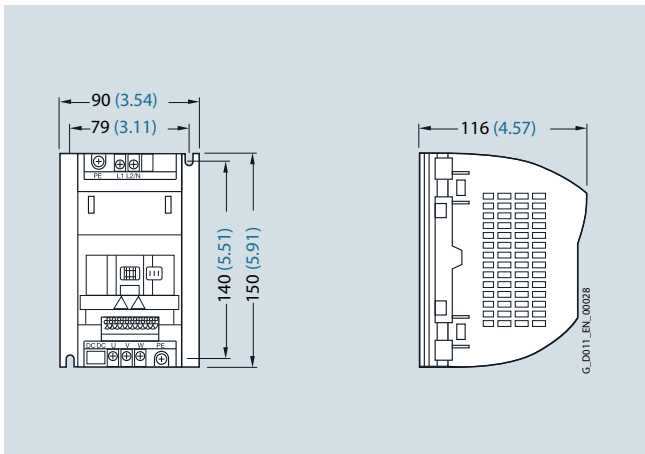

Inverter frame size FSA; 0.12 kW to 0.37 kW (0.16 hp to 0.5 hp)

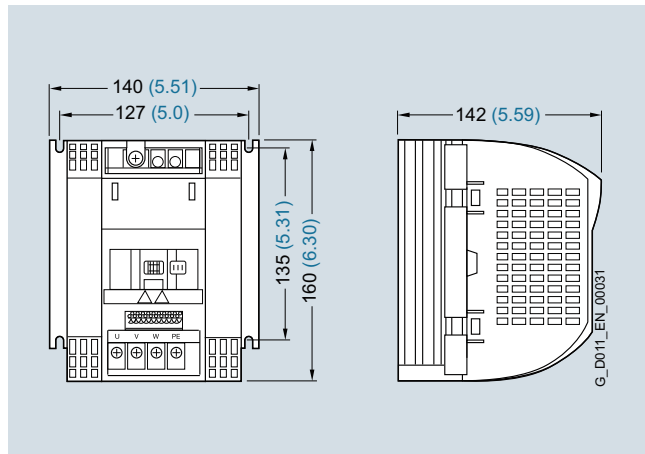

Inverter frame size FSB; 1.1 kW to 1.5 kW (1.5 hp to 2 hp)

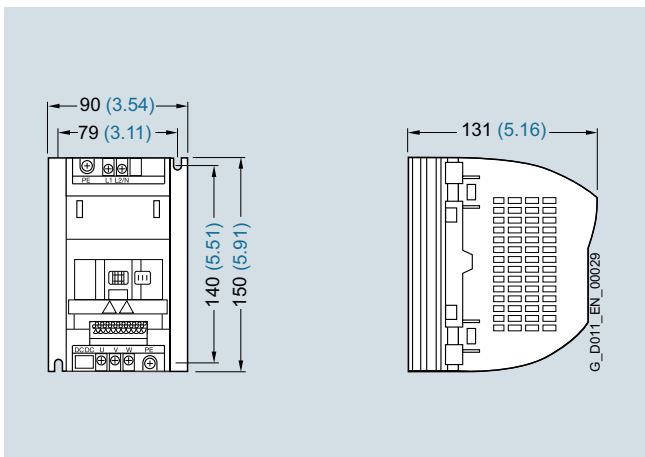

Inverter frame size FSA; 0.55 kW to 0.75 kW (0.75 hp to 1 hp)

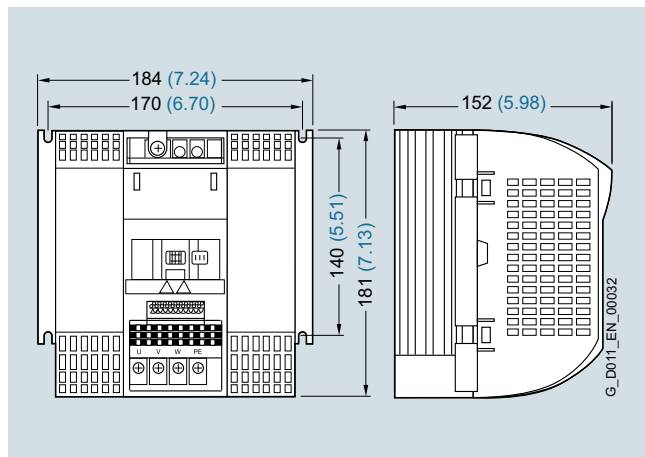

Inverter frame size FSC; 2.2 kW to 3 kW (3 hp to 4 hp)

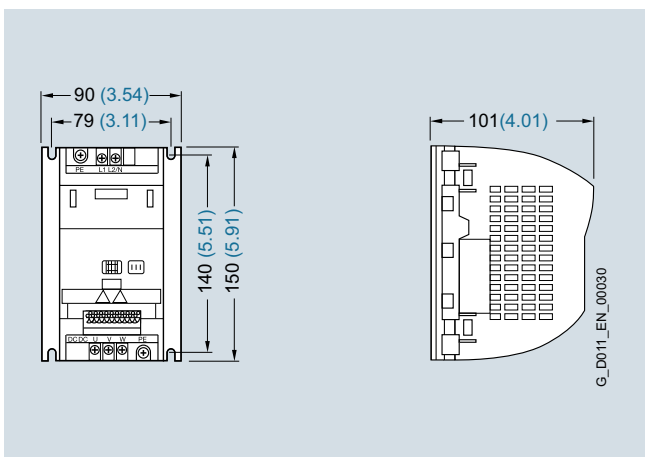

Inverter frame size FSA with flat heat sink; 0.12 kW to 0.75 kW (0.16 hp to 1 hp)

Mounted using screws and washers (not included in the scope of supply)

- Frame size FSA: 2 × M4
- Frame size FSB: 4 × M4
- Frame size FSC: 4 × M5

With attached operator panel (BOP), the mounting depth is increased by 8 mm (0.31 inches).

All dimensions in mm (values in brackets are in inches).

SINAMICS G110 standard inverters

0.12 kW to 3 kW (0.16 hp to 4 hp)

Controlled Power Modules

Schematics

Block diagram

3

