

## SINAMICS G120C compact inverters

0.55 kW to 18.5 kW (0.75 hp to 25 hp)

### SINAMICS G120C compact inverters

#### Overview



SINAMICS G120C frame sizes FSA, FSA, FSB and FSC with mounted blanking cover

SINAMICS G120C compact inverters offer a well-balanced combination of features to address a wide range of applications. They are compact, rugged devices that are easy to operate and can be optionally equipped with a basic or advanced operator panel.

SINAMICS G120C inverters are especially suitable when it comes to meeting the requirements of system integrators, OEMs and distributors regarding high productivity and tailored performance.

#### Benefits

- Compact design
- Side-by-side design
- High power density, low envelope dimensions
- Simple installation in the tightest space
- Low space requirement
- Use in small control cabinets, close to the machine
- Optimized parameter set
- Optimized commissioning
- Getting Started document
- BOP-2 or IOP operator panels can be used
- Integrated USB connection
- Simple and fast software parameter assignment
- Simple to use during commissioning and in operation
- Minimized training costs, existing SINAMICS know-how can be used
- High degree of service friendliness, simple maintenance
- Plug-in terminals
- Cloning function using BOP-2, IOP or memory card
- Operating hours counter for "drive on" and "motor on"
- Fast mechanical installation
- Intuitive standard commissioning
- Component of Totally Integrated Automation
- Energy-efficient, sensorless vector control
- Automatic flux reduction with V/f ECO
- Integrated energy saving computer
- Safety Integrated (STO)
- Communications versions with PROFINET / EtherNet/IP, PROFIBUS DP, USS/Modbus RTU
- Coated modules
- Operation up to an ambient temperature of 60 °C (140 °F)

#### Design

SINAMICS G120C is a compact inverter for control cabinet mounting in IP20 degree of protection where the Control Unit (CU) and Power Module (PM) function units are combined in one device.

The compact mechanical design and the high power density allow these devices to be installed in machine control enclosures and control cabinets for maximum space utilization. The SINAMICS G120C compact inverter can be butt-mounted directly, without derating at temperatures up to 40 °C.



SINAMICS G120C, frame size FSA with BOP-2

SINAMICS G120C can be integrated into the widest range of applications, either using the integrated digital and analog inputs or via the integrated fieldbus interface (available in USS, Modbus RTU, PROFIBUS, PROFINET / EtherNet/IP versions). Especially the product versions with integrated PROFIBUS/PROFINET interface make full integration into the Siemens TIA family possible, therefore allowing the advantages of the seamless TIA product family to be fully utilized. SINAMICS G120C devices are preset in the factory so that they can be immediately connected to PROFIBUS and/or PROFINET fieldbus systems without parameterization.

SINAMICS G120C is also equipped with the safety function STO (Safe Torque Off) as standard, which is used to safely stop drives. As a consequence, machine manufacturers can simply comply with current machinery directives with minimum associated costs.

SINAMICS G120C can control asynchronous (induction) motors in the power range from 0.37 kW up to 18.5 kW (0.5 hp up to 25 hp). Reliable and efficient motor operation is achieved by using state-of-the-art IGBT technology combined with vector control. The extensive range of functions integrated in the SINAMICS G120C also offers a high degree of protection for the inverter and motor.

## SINAMICS G120C compact inverters

0.55 kW to 18.5 kW (0.75 hp to 25 hp)

### SINAMICS G120C compact inverters

#### Design

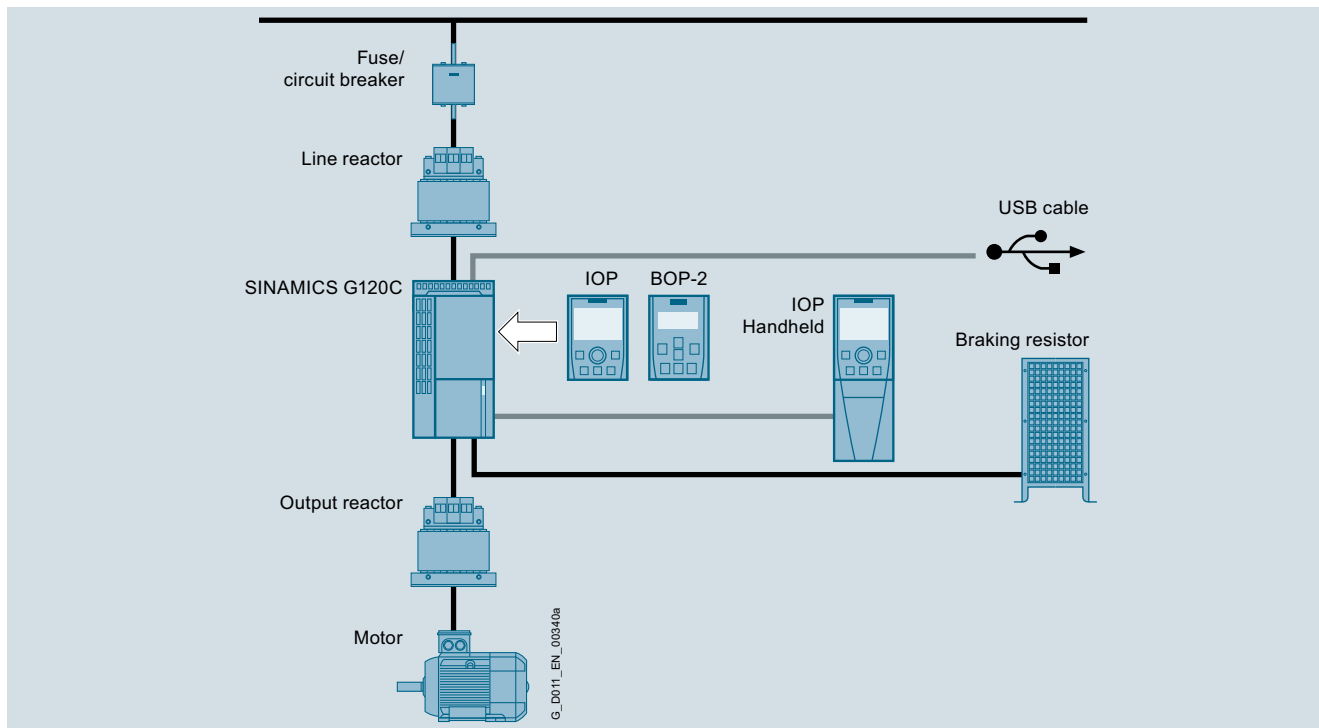

#### Line-side components

##### Line reactors

Line reactors smooth the current drawn by the inverter and thus reduce harmonic components in the line current. Through the reduction of the current harmonics, the thermal load on the power components in the rectifier and in the DC-link capacitors is reduced as well as the harmonic effects on the supply. The use of a line reactor increases the service life of the inverter.

##### Recommended line-side power components

Standard fuses can be used for the SINAMICS G120C. These must be dimensioned to comply with local regulations. In this chapter, you will find recommended components such as fuses and circuit breakers in compliance with IEC and UL regulations.

#### DC link components

##### Braking resistors

The excess energy of the DC link is dissipated using the braking resistor. The braking resistors are designed for use with the SINAMICS G120C. This has an integrated brake chopper (electronic switch).

#### Load-side power components

##### Output reactors

Output reactors reduce the rate of voltage rise (dv/dt) and the height of the current peaks, and enable longer motor cables to be connected.

#### Supplementary system components

##### Intelligent Operator Panel IOP

Graphics-based, user-friendly and powerful operator panel for commissioning and diagnostics as well as local operator control and monitoring of SINAMICS G120C.

##### Basic Operator Panel BOP-2

A 2-line display to provide support when commissioning and troubleshooting the drive. The drive can be locally controlled.

##### Memory card

The parameter settings for an inverter can be stored on the SINAMICS SD memory card. When service is required, e.g. after the inverter has been replaced and the data have been downloaded from the memory card the drive system is immediately ready for use again. The associated memory card holder is integrated in the inverter.

##### PC inverter connection kit 2

For controlling and commissioning an inverter directly from a PC if the STARTER commissioning tool or SINAMICS Startdrive has been installed on the PC.

#### Spare parts

##### Shield plates

A set of shield plates is included in the scope of delivery for the motor and signal cables corresponding to the frame size of the SINAMICS G120C, and can also be ordered as spare parts.

##### Spare Parts Kit

This kit comprises 4 sets of I/O terminals, 1 RS485 terminal, 2 sets of Control Unit doors (1 × PN and 1 × other communication versions) and 1 blanking cover.

##### Set of connectors

A set of connectors for the line feeder cable, braking resistor and motor cable can be ordered corresponding to the frame size of the SINAMICS G120C inverter.

##### Roof-mounted fan

A roof-mounted fan (at the top of the device) comprising a pre-assembled unit with holder and fan can be ordered corresponding to the frame size of the SINAMICS G120C.

##### Fan unit

A replacement fan (at the rear of the device; heat sink) comprising a pre-assembled unit with holder and fan can be ordered corresponding to the frame size of the SINAMICS G120C.

## Configuration

The following electronic configuring aids and engineering tools are available for SINAMICS G120C compact inverters:

### **Drive Technology Configurator (DT Configurator) within the CA 01**

The interactive catalog CA 01 – the offline Industry Mall of Siemens on DVD-ROM – contains over 100 000 products with approximately 5 million possible drive system product variants. The Drive Technology Configurator (DT Configurator) has been developed to facilitate selection of the correct motor and/or inverter from the wide spectrum of drives. It is integrated as a selection tool in Catalog CA 01.

### **Online DT Configurator**

In addition, the DT Configurator can be used on the Internet without requiring any installation. The DT Configurator can be found in the Siemens Industry Mall at the following address:  
[www.siemens.com/dt-configurator](http://www.siemens.com/dt-configurator)

### **SIZER for Siemens Drives engineering tool**

The SIZER for Siemens Drives engineering tool makes it easy to engineer the SINAMICS and MICROMASTER 4 drive families. It provides support when selecting the hardware and firmware components necessary to implement a drive task. SIZER for Siemens Drives is designed to support configuring of the entire drive system.

You can find further information on the SIZER for Siemens Drives engineering tool in the chapter [Engineering tools](#).

The SIZER for Siemens Drives engineering tool is available free on the Internet at  
[www.siemens.com/sizer](http://www.siemens.com/sizer)

### **STARTER commissioning tool**

The STARTER commissioning tool allows menu-prompted commissioning, optimization and diagnostics. Apart from the SINAMICS drives, STARTER is also suitable for MICROMASTER 4 devices.

You can find further information about the STARTER commissioning tool in the chapter [Engineering tools](#).

Additional information about the STARTER commissioning tool is available on the Internet at  
[www.siemens.com/starter](http://www.siemens.com/starter)

### **SINAMICS Startdrive commissioning tool**

SINAMICS Startdrive is a tool for configuring, commissioning, and diagnosing the SINAMICS family of drives and is integrated into the TIA Portal. SINAMICS Startdrive can be used to implement drive tasks with the SINAMICS G110M, SINAMICS G120, SINAMICS G120C, SINAMICS G120D and SINAMICS G120P inverter series. The commissioning tool has been optimized with regard to user friendliness and consistent use of the TIA Portal benefits of a common working environment for PLC, HMI and drives.

You can find further information on the SINAMICS Startdrive commissioning tool in the chapter [Engineering tools](#).

The SINAMICS Startdrive commissioning tool is available free on the Internet at  
[www.siemens.com/startdrive](http://www.siemens.com/startdrive)

### **Drive ES engineering system**

Drive ES is the engineering system that can be used to integrate the communication, configuration and data management functions of Siemens drive technology into the SIMATIC automation world easily, efficiently and cost-effectively. Two software packages are available for SINAMICS – Drive ES Basic and Drive ES PCS.

You can find further information about the Drive ES engineering system in the chapter [Engineering tools](#).

Additional information about the Drive ES engineering system is available on the Internet at  
[www.siemens.com/drive-es](http://www.siemens.com/drive-es)

# SINAMICS G120C compact inverters

0.55 kW to 18.5 kW (0.75 hp to 25 hp)

## SINAMICS G120C compact inverters

### Integration

4

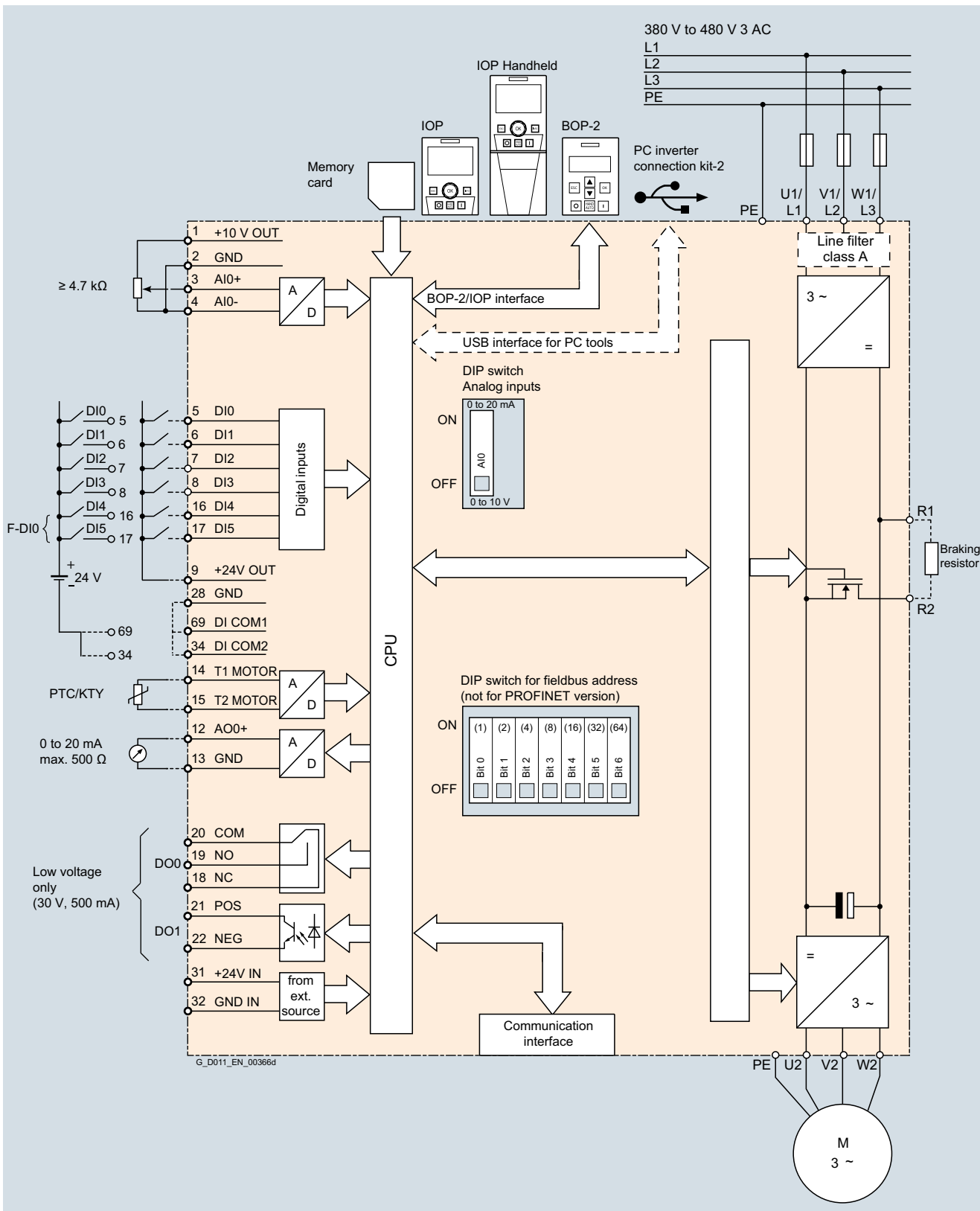

Connection example for SINAMICS G120C

**Integration**

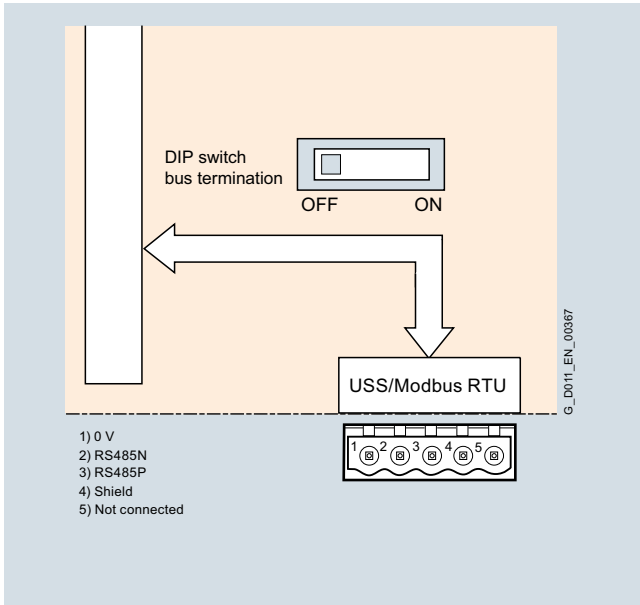

USS/Modbus RTU communication interface

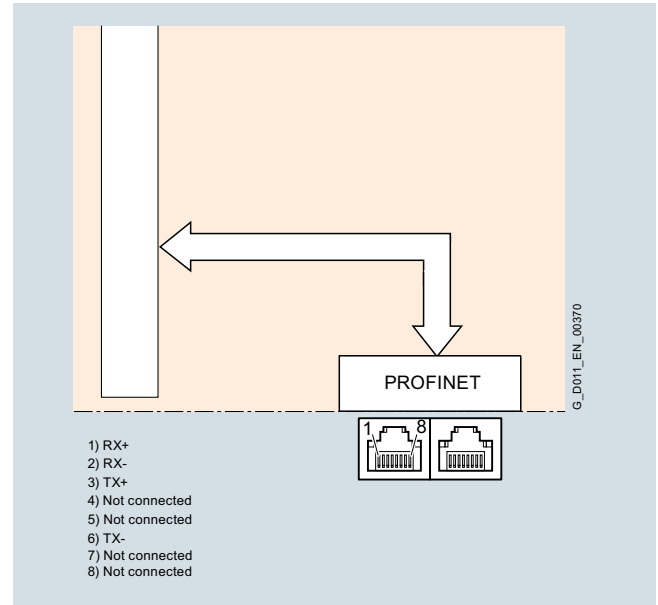

PROFINET, EtherNet/IP communication interface

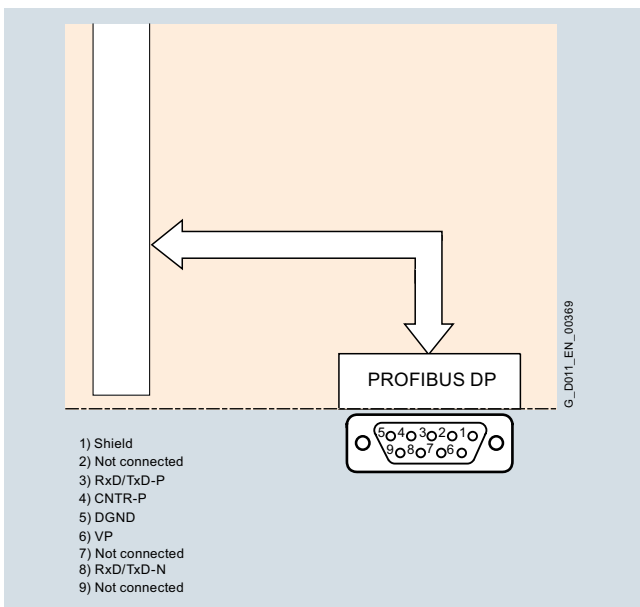

PROFIBUS DP communication interface

## SINAMICS G120C compact inverters

0.55 kW to 18.5 kW (0.75 hp to 25 hp)

### SINAMICS G120C compact inverters

#### Selection and ordering data

The article number is selected corresponding to

- the required motor power or the motor current required and the overload requirements of the application,
- the necessary EMC classification and
- the required integrated fieldbus interface

Rated power <sup>1)</sup>		Base-load current $I_L$ <sup>2)</sup>	Base-load current $I_H$ <sup>3)</sup>	Frame size	Version	SINAMICS G120C without line filter		SINAMICS G120C with integrated line filter class A	
kW	hp					Article No.		Article No.	
<b>380 ... 480 V 3 AC</b>									
0.55	0.75	1.7	1.3	FSAA	USS, Modbus RTU	<b>NEW</b>	6SL3210-1KE11-8UB2	<b>NEW</b>	6SL3210-1KE11-8AB2
					PROFIBUS DP	<b>NEW</b>	6SL3210-1KE11-8UP2	<b>NEW</b>	6SL3210-1KE11-8AP2
					PROFINET, EtherNet/IP	<b>NEW</b>	6SL3210-1KE11-8UF2	<b>NEW</b>	6SL3210-1KE11-8AF2
0.75	1	2.2	1.7	FSAA	USS, Modbus RTU	<b>NEW</b>	6SL3210-1KE12-3UB2	<b>NEW</b>	6SL3210-1KE12-3AB2
					PROFIBUS DP	<b>NEW</b>	6SL3210-1KE12-3UP2	<b>NEW</b>	6SL3210-1KE12-3AP2
					PROFINET, EtherNet/IP	<b>NEW</b>	6SL3210-1KE12-3UF2	<b>NEW</b>	6SL3210-1KE12-3AF2
1.1	1.5	3.1	2.2	FSAA	USS, Modbus RTU	<b>NEW</b>	6SL3210-1KE13-2UB2	<b>NEW</b>	6SL3210-1KE13-2AB2
					PROFIBUS DP	<b>NEW</b>	6SL3210-1KE13-2UP2	<b>NEW</b>	6SL3210-1KE13-2AP2
					PROFINET, EtherNet/IP	<b>NEW</b>	6SL3210-1KE13-2UF2	<b>NEW</b>	6SL3210-1KE13-2AF2
1.5	2	4.1	3.1	FSAA	USS, Modbus RTU	<b>NEW</b>	6SL3210-1KE14-3UB2	<b>NEW</b>	6SL3210-1KE14-3AB2
					PROFIBUS DP	<b>NEW</b>	6SL3210-1KE14-3UP2	<b>NEW</b>	6SL3210-1KE14-3AP2
					PROFINET, EtherNet/IP	<b>NEW</b>	6SL3210-1KE14-3UF2	<b>NEW</b>	6SL3210-1KE14-3AF2
2.2	3	5.6	4.1	FSAA	USS, Modbus RTU	<b>NEW</b>	6SL3210-1KE15-8UB2	<b>NEW</b>	6SL3210-1KE15-8AB2
					PROFIBUS DP	<b>NEW</b>	6SL3210-1KE15-8UP2	<b>NEW</b>	6SL3210-1KE15-8AP2
					PROFINET, EtherNet/IP	<b>NEW</b>	6SL3210-1KE15-8UF2	<b>NEW</b>	6SL3210-1KE15-8AF2
3	4	7.3	5.6	FSA	USS, Modbus RTU		6SL3210-1KE17-5UB1		6SL3210-1KE17-5AB1
					PROFIBUS DP		6SL3210-1KE17-5UP1		6SL3210-1KE17-5AP1
					PROFINET, EtherNet/IP		6SL3210-1KE17-5UF1		6SL3210-1KE17-5AF1
4	5	8.8	7.3	FSA	USS, Modbus RTU		6SL3210-1KE18-8UB1		6SL3210-1KE18-8AB1
					PROFIBUS DP		6SL3210-1KE18-8UP1		6SL3210-1KE18-8AP1
					PROFINET, EtherNet/IP		6SL3210-1KE18-8UF1		6SL3210-1KE18-8AF1
5.5	7.5	12.5	8.8	FSB	USS, Modbus RTU		6SL3210-1KE21-3UB1		6SL3210-1KE21-3AB1
					PROFIBUS DP		6SL3210-1KE21-3UP1		6SL3210-1KE21-3AP1
					PROFINET, EtherNet/IP		6SL3210-1KE21-3UF1		6SL3210-1KE21-3AF1
7.5	10	16.5	12.5	FSB	USS, Modbus RTU		6SL3210-1KE21-7UB1		6SL3210-1KE21-7AB1
					PROFIBUS DP		6SL3210-1KE21-7UP1		6SL3210-1KE21-7AP1
					PROFINET, EtherNet/IP		6SL3210-1KE21-7UF1		6SL3210-1KE21-7AF1
11	15	25	16.5	FSC	USS, Modbus RTU		6SL3210-1KE22-6UB1		6SL3210-1KE22-6AB1
					PROFIBUS DP		6SL3210-1KE22-6UP1		6SL3210-1KE22-6AP1
					PROFINET, EtherNet/IP		6SL3210-1KE22-6UF1		6SL3210-1KE22-6AF1
15	20	31	25	FSC	USS, Modbus RTU		6SL3210-1KE23-2UB1		6SL3210-1KE23-2AB1
					PROFIBUS DP		6SL3210-1KE23-2UP1		6SL3210-1KE23-2AP1
					PROFINET, EtherNet/IP		6SL3210-1KE23-2UF1		6SL3210-1KE23-2AF1
18.5	25	37	31	FSC	USS, Modbus RTU		6SL3210-1KE23-8UB1		6SL3210-1KE23-8AB1
					PROFIBUS DP		6SL3210-1KE23-8UP1		6SL3210-1KE23-8AP1
					PROFINET, EtherNet/IP		6SL3210-1KE23-8UF1		6SL3210-1KE23-8AF1

<sup>1)</sup> The rated power of the device based on the rated output current  $I_L$  and a rated input voltage of 400 V 3 AC. The rated power is specified on the device rating plate.

<sup>2)</sup> The base-load current  $I_L$  is based on the duty cycle for low overload (LO). The current value is specified on the device rating plate.

<sup>3)</sup> The base-load current  $I_H$  is based on the duty cycle for high overload (HO). The current value is not specified on the device rating plate.