

Overview



SITRANS WM100 is a heavy-duty zero-speed alarm switch. This non-contacting unit provides cost-effective equipment protection even in the harshest conditions.

Benefits

- Up to 100 mm (4 inch) gap between SITRANS WM100 and targets
- Rugged, low maintenance suitable for tough environments
- 1 SPDT Form C relay contact
- Provides cost-effective protection
- Visual indication of target triggered pulse

Application

This rugged unit is impervious to dust, dirt, build-up and moisture and is ideal for such primary industries as mining, aggregate, and cement. Operating where other systems are prone to failure, the non-contacting design eliminates the need for lubricating, cleaning and part replacement. Downtime and clean-up expenses associated with conveying equipment failure are reduced by the SITRANS WM100. It alarms to minimize spillage, prevent extensive damage or even fire caused by belt slippage at the head pulley, and warns against conveyor malfunction.

The SITRANS WM100 has built-in selectable start delays and 1 Form C relay contact. With an aluminum body, it operates from -40 to +60 °C (-40 to +140 °F).

- Key Applications: tail pulleys, driven pulleys, motor shaft sensing, screw conveyor flights, bucket elevators

Design

Mounting

The WM100 probe should be mounted, using the supplied mounting flange, onto a vibration-free structure. The gap between the probe and the target should be sufficient such that there is no danger of the target damaging the probe. The maximum allowable gap is 100 mm (4 inch) from the face of the target to the face of the probe for 4.5 x 4.5 mm (3/16 x 3/16 inch) keyway. The WM100 is sensitive to lateral disturbances to its magnetic field. If the WM100 is responding to motion from an interfering target, move the WM100 or install a ferrous plate (steel) as a shield between the WM100 and the interfering target. Where possible, the probe should be mounted such that the cable inlet is pointing downward to avoid accumulation of condensation in the casing. Connection of the probe should be made via flexible conduit for easier removal or adjustment of the probe.

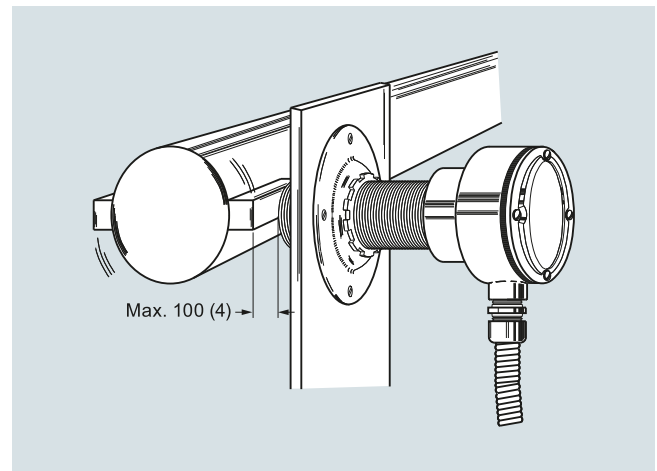

SITRANS WM100 mounting, dimensions in mm (inch)

Process Protection

Motion sensors

SITRANS WM100 Motion sensor

Technical specifications

Mode of operation	
Measuring principle	Disruption of magnetic field by ferrous target
Typical application	Monitors absence or presence of motion in harsh conditions
Output	
Contact	1 SPDT Form C dry relay contact, rated 5 A at 250 V AC, fail-safe operation
Time delay	Start up: 10 ... 14 seconds (5 ... 7 seconds with 12 ppm jumper installed)
Zero Speed (selected via a common jumper)	5 seconds ± 1 (minimum speed 10 ... 15 ppm) or 10 seconds ± 2 (minimum speed 5 ... 7.5 ppm)
Rated operating conditions	
Operating temperature	-40 ... +60 °C (-40 ... +140 °F)
Storage temperature	-40 ... +60 °C (-40 ... +140 °F)
Design	
Probe body	Aluminum
Process mounting	2" NPSL
Connection box	Aluminum, ¾" NPT conduit entrance, 5 screw terminals plus grounding terminal for electrical connection, max. 12 AWG (3.30 mm ²) wire size
Gasketing	Neoprene
Display	Red LED for verification of pulses
Enclosure rating	Type NEMA 4x, 6, IP67
Dynamic range	
	Minimum 6 or 12 pulses per minute Maximum 3 000 pulses per minute
Shipping weight	
	2 kg (4.4 lb)
Power supply	
	<ul style="list-style-type: none"> • 115 V AC/50 ... 60 Hz, 7 VA • 230 V AC/50 ... 60 Hz, 7 VA • ± 10 % of rated voltage
Certificates and approvals	
	CSA _{US/C} , CE, RCM, EAC, KCC

Selection and ordering data

SITRANS WM100 Motion sensor		Article No.
Heavy duty speed alarm switch with 100 mm measuring range. ↗ Click on the Article No. for the online configuration in the PIA Life Cycle Portal.	↗ 7MH7158 - 0 A 0 0 A B	
Model		
	115 V AC	
	230 V AC	
Further designs		Order code
Please add "-Z" to Article No. and specify Order code(s).		
Manufacturer's Test Certificate: According to EN 10204-2.2		C11
Acrylic coated, stainless steel tag [13 x 45 mm (0.5 x 1.75 inch)]; Measuring-point number/I-identification (max. 16 characters), specify in plain text		Y17
Operating Instructions		
All literature is available to download for free, in a range of languages, at http://www.siemens.com/processinstrumentation/documentation		
Accessories		Article No.
Locknut		7MH7723-1CR
Mounting flange		7MH7723-1CS
Motion cable gland adaptor kit		7MH7723-1JU