

## SITOP power supply

### SITOP PSU6200 1ph

#### Manual

SITOP PSU6200 12 V/7 A  
6EP3323-7SB00-0AX0  
SITOP PSU6200 12 V/12 A  
6EP3324-7SB00-3AX0  
SITOP PSU6200 24 V/3.7 A  
6EP3333-7LB00-0AX0  
SITOP PSU6200 24 V/5 A  
6EP3333-7SB00-0AX0  
SITOP PSU6200 24 V/10 A  
6EP3334-7SB00-3AX0  
SITOP PSU6200 24 V/20 A  
6EP3336-7SB00-3AX0

#### Overview

---

Notes on safety

1

Description, device design,  
dimension drawing

2

Mounting/removal

3

Mounting position, mounting  
clearances

4

Installation

5

Technical data

6

Safety, approvals, EMC

7

Ambient conditions

8

Applications

9

Environment

10

Service & Support

11

## Legal information

### Warning notice system

This manual contains notices you have to observe in order to ensure your personal safety, as well as to prevent damage to property. The notices referring to your personal safety are highlighted in the manual by a safety alert symbol, notices referring only to property damage have no safety alert symbol. These notices shown below are graded according to the degree of danger.

#### **DANGER**

indicates that death or severe personal injury **will** result if proper precautions are not taken.

#### **WARNING**

indicates that death or severe personal injury **may** result if proper precautions are not taken.

#### **CAUTION**

indicates that minor personal injury can result if proper precautions are not taken.

#### **NOTICE**

indicates that property damage can result if proper precautions are not taken.

If more than one degree of danger is present, the warning notice representing the highest degree of danger will be used. A notice warning of injury to persons with a safety alert symbol may also include a warning relating to property damage.

### Qualified Personnel

The product/system described in this documentation may be operated only by **personnel qualified** for the specific task in accordance with the relevant documentation, in particular its warning notices and safety instructions. Qualified personnel are those who, based on their training and experience, are capable of identifying risks and avoiding potential hazards when working with these products/systems.

### Proper use of Siemens products

Note the following:

#### **WARNING**

Siemens products may only be used for the applications described in the catalog and in the relevant technical documentation. If products and components from other manufacturers are used, these must be recommended or approved by Siemens. Proper transport, storage, installation, assembly, commissioning, operation and maintenance are required to ensure that the products operate safely and without any problems. The permissible ambient conditions must be complied with. The information in the relevant documentation must be observed.

### Trademarks

All names identified by ® are registered trademarks of Siemens AG. The remaining trademarks in this publication may be trademarks whose use by third parties for their own purposes could violate the rights of the owner.

### Disclaimer of Liability

We have reviewed the contents of this publication to ensure consistency with the hardware and software described. Since variance cannot be precluded entirely, we cannot guarantee full consistency. However, the information in this publication is reviewed regularly and any necessary corrections are included in subsequent editions.

# Overview



Figure 1 View of devices

The 1-phase SITOP PSU6200 from the product line is a powerful, regulated standard power supply for automated machines and systems. In addition to a high efficiency, these low-profile power supply units have an outstanding overload behavior.

The key benefits of the product include:

- Wide-range input that allows it to be connected to almost any 1-phase line supply around the world – or to a DC power source
- The output voltage can be set in the range 12 V - 15.5 V or 24 V - 28 V
- Brief overload capability of 150% for 5 s/min (extra power)
- Continuous overload capability of 120% up to an ambient temperature of 45 °C
- Integrated signaling contact for "12 V O.K." or "24 V O.K."
- Push-in connections facilitate fast wiring
- Diagnostic monitor with utilization and service life display using LEDs
- Diagnostics interface to connect to the automation system via only one digital PLC input
- Ambient temperature -25 °C ... 70 °C
- To increase the system availability, these reliable power supplies can be expanded using SITOP supplementary modules (redundancy module, selectivity module, buffer module), as well as SITOP DC-UPS modules.

## Ordering data

The following device options are available:

Regulated SITOP PSU6200S power supply	
Type	Order number
Input 1 AC 120/230 V, 110 - 240 V DC Output 12 V DC/7 A	6EP3323-7SB00-0AX0
Input 1 AC 120/230 V, 110 - 240 V DC Output 12 V DC/12 A	6EP3324-7SB00-3AX0
Input 1 AC 120/230 V, 120 - 240 V DC Output 24 V DC/3.7 A	6EP3333-7LB00-0AX0
Input 1 AC 120/230 V, 120 - 240 V DC Output 24 V DC/5 A	6EP3333-7SB00-0AX0
Input 1 AC 120/230 V, 120 - 240 V DC 24 V/10 A DC output	6EP3334-7SB00-3AX0
Input 1 AC 120/230 V, 120 - 240 V DC 24 V/20 A DC output	6EP3336-7SB00-3AX0

Accessories	
Type	Order number
Reference labeling plate (160 plates)	6ES7193-6LF30-0AW0

# Table of contents

	Overview.....	3
<b>1</b>	<b>Notes on safety.....</b>	<b>7</b>
<b>2</b>	<b>Description, device design, dimension drawing .....</b>	<b>9</b>
2.1	Device description.....	9
2.2	Connections and terminal designation.....	10
2.3	Potentiometer.....	11
2.4	Status displays and signaling .....	12
2.5	Operating mode .....	15
2.6	Block diagram .....	16
2.7	Dimensions and weight.....	18
<b>3</b>	<b>Mounting/removal .....</b>	<b>21</b>
<b>4</b>	<b>Mounting position, mounting clearances.....</b>	<b>23</b>
4.1	Standard mounting position .....	23
4.2	Other mounting positions.....	26
4.2.1	6EP3323-7SB00-0AX0 .....	26
4.2.2	6EP3324-7SB00-3AX0 .....	28
4.2.3	6EP3333-7LB00-0AX0 .....	30
4.2.4	6EP3333-7SB00-0AX0 .....	32
4.2.5	6EP3334-7SB00-3AX0 .....	34
4.2.6	6EP3336-7SB00-3AX0 .....	36
<b>5</b>	<b>Installation .....</b>	<b>39</b>
5.1	Line-side connection .....	39
5.2	Output-side connection .....	41
<b>6</b>	<b>Technical data .....</b>	<b>43</b>
6.1	Input .....	43
6.2	Output .....	46
6.3	Efficiency.....	52
6.4	Closed-loop control.....	56
6.5	Protection and monitoring.....	57
6.6	MTBF .....	58
6.7	Mechanical system .....	59
6.8	Dimension drawing .....	60

<b>7</b>	<b>Safety, approvals, EMC .....</b>	<b>61</b>
7.1	Safety .....	61
7.2	Test voltage.....	62
7.3	Approvals .....	63
7.4	EMC .....	64
<b>8</b>	<b>Ambient conditions .....</b>	<b>65</b>
<b>9</b>	<b>Applications .....</b>	<b>67</b>
9.1	Parallel connection to increase the power rating .....	67
9.2	Overload protection in the 24 V output circuit.....	69
9.3	Protection against short-time voltage dips .....	70
9.4	Protecting against longer power failures.....	71
<b>10</b>	<b>Environment .....</b>	<b>73</b>
<b>11</b>	<b>Service &amp; Support.....</b>	<b>75</b>

 **WARNING**

**Correct handling of the devices**

When operating electrical devices, it is inevitable that certain components will carry dangerous voltages.

Therefore, failure to handle the units properly can result in death or serious physical injury as well as extensive property damage.

Only appropriately qualified personnel may work on or in the vicinity of this equipment.

Perfect, safe, and reliable operation of this equipment is dependent on proper transportation, storage, installation and mounting.

Before installation or maintenance work can begin, the system's main switch must be switched off and measures taken to prevent it being switched on again.

If this instruction is not observed, touching live parts can result in death or serious injury.



## Description, device design, dimension drawing

### 2.1 Device description

SITOP PSU6200 is a primary-clocked power supply for connection to a 1-phase AC line supply and a DC supply. An electronically regulated DC voltage that can be set via a potentiometer is available at the output of the device. The output of the device is isolated, no-load proof and short-circuit proof. The LED display indicates the operating status. The operating state of the device can be processed via the signaling contact.

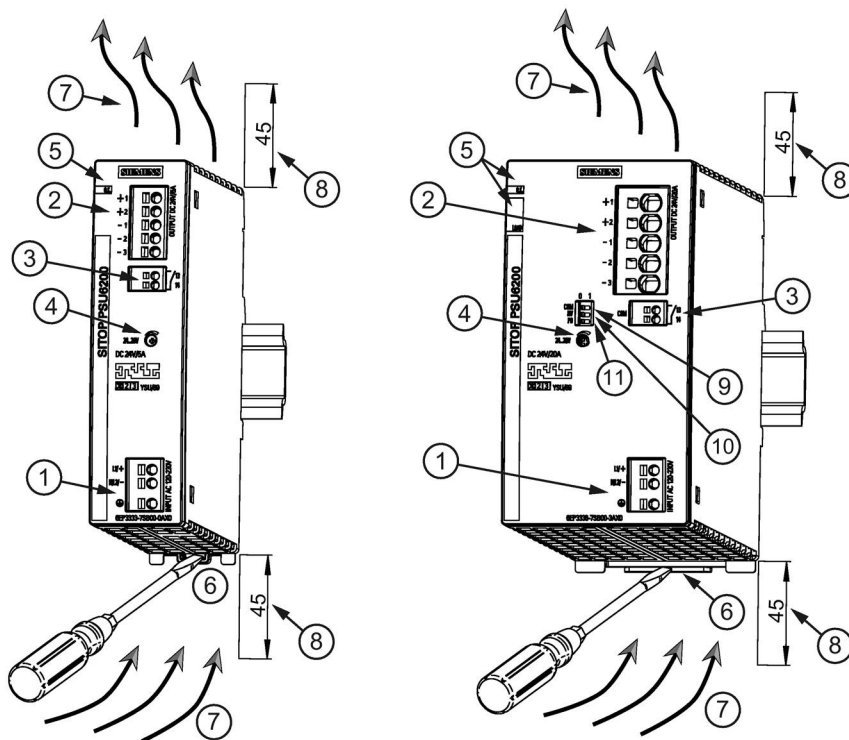

- ① AC/DC input
- ② DC output
- ③ Signaling contact (13, 14)
- ④ Potentiometer, 12 V - 15.5 V or 24 V - 28 V
- ⑤ Indicator light, diagnostics monitor (O.K., LOAD)
- ⑥ DIN rail slider
- ⑦ Convection
- ⑧ Clearance above/below
- ⑨ Diagnostics interface (COM)
- ⑩ DC voltage level increase (HV)
- ⑪ Parallel operation (PO)





Figure 2-1 Design

## 2.2 Connections and terminal designation

The line input terminals ① can be used to establish the connection to supply voltage. The output terminals ② are used to connect to the loads to be supplied (see also Section Installation (Page 39)).





The operating state of the device can be processed via the signaling contact ③ (function and contact rating, see Chapter Status displays and signaling (Page 12)).

Connections and terminal designations	
① Line input L1, N (L2), PE	one spring-loaded terminal each
② Output +	2 spring-loaded terminals
② Output -	3 spring-loaded terminals
③ Signaling contact 13, 14	one spring-loaded terminal each

	① + ②	③	④
	0,6 x 3,5	0,6 x 3,5	0,6 x 3 / PZ1 / PH1 max. Ø 3,5 mm
	1 x 0,2 - 4 mm <sup>2</sup>	1 x 0,2 - 1,5 mm <sup>2</sup>	-
	1 x 0,2 - 2,5 mm <sup>2</sup>	1 x 0,2 - 1,5 mm <sup>2</sup>	-
	1 x 0,25 - 2,5 mm <sup>2</sup>	1 x 0,25 - 1,5 mm <sup>2</sup>	-
AWG	24 - 12	24 - 16	-
Nm	-	-	0,04 Nm <sup>*)</sup>
	10 mm	10 mm	-

<sup>\*)</sup> Do not subject the end stop to higher loads

Figure 2-2 Terminal data for 6EP3323-7SB00-0AX0, 6EP3324-7SB00-3AX0, 6EP3333-7LB00-0AX0, 6EP3333-7SB00-0AX0 and 6EP3334-7SB00-3AX0

	①	②	③	④
	0,6 x 3,5	0,6 x 3,5	0,6 x 3,5	0,6 x 3 / PZ1 / PH1 max. Ø 3,5 mm
	1 x 0,2 - 4 mm <sup>2</sup>	1 x 0,2 - 10 mm <sup>2</sup>	1 x 0,2 - 1,5 mm <sup>2</sup>	-
	1 x 0,2 - 2,5 mm <sup>2</sup>	1 x 0,5 - 6 mm <sup>2</sup>	1 x 0,2 - 1,5 mm <sup>2</sup>	-
	1 x 0,25 - 2,5 mm <sup>2</sup>	1 x 0,5 - 6 mm <sup>2</sup>	1 x 0,25 - 1,5 mm <sup>2</sup>	-
AWG	24 - 12	24 - 8	24 - 16	-
Nm	-	-	-	0,04 Nm <sup>*)</sup>
	10 mm	15 mm	10 mm	-

<sup>\*)</sup> Do not subject the end stop to higher loads

Figure 2-3 Terminal data for 6EP3336-7SB00-3AX0

## 2.3 Potentiometer

The potentiometer ④ on the front of the device is used to adjust the output voltage. The output voltage is set to the rated value at the factory and can be set within certain limits; for example, to compensate voltage drops across long supply lines to the connected load.

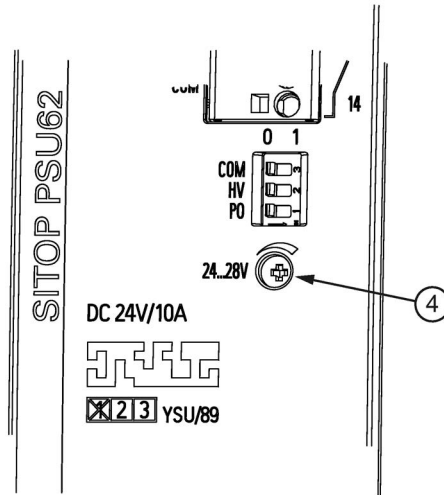

Figure 2-4 Potentiometer

Type	Factory setting	Adjustment range
6EP3323-7SB00-0AX0	12 V	12 V - 15.5 V
6EP3324-7SB00-3AX0		
6EP3333-7LB00-0AX0	24 V	24 V - 28 V
6EP3333-7SB00-0AX0		
6EP3334-7SB00-3AX0		
6EP3336-7SB00-3AX0		

### NOTICE

#### Thermal overload possible

When adjusting the output voltage to greater than the rated voltage, the output current must be derated by 4 %/V (for devices with a rated output voltage of 24 V) and 8 %/V (for devices with a rated output voltage of 12 V) – or the permissible ambient temperature must be taken into account with 3 °C/V.

### Note

It is only permissible to use an insulated screwdriver when actuating the potentiometer.

For information on actuating the potentiometer (screwdriver, torque), see Connections and terminal designation (Page 10).

## 2.4 Status displays and signaling

	6EP3323-7SB00-0AX0 (12 V/7 A), 6EP3324-7SB00-3AX0 (12 V/12 A), 6EP3333-7LB00-0AX0 (24 V/3,7 A), 6EP3333-7SB00-0AX0 (24 V/5 A), 6EP3334-7SB00-3AX0 (24 V/10 A), 6EP3336-7SB00-3AX0 (24 V/20 A)
Status display	LED green for 12 V O.K. or 24 V O.K. Yellow LED
Signaling contact (13, 14)	Relay contact (NO contact, contact rating (isolated) 24 V AC/0.1 A; 30 V DC/0.1 A

### Device without diagnostics monitor

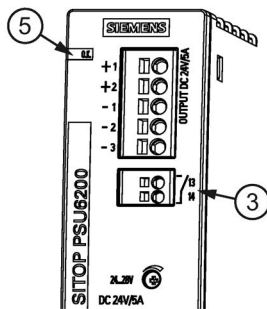

Figure 2-5 Signaling, signaling contact

Signaling	6EP3323-7SB00-0AX0 (12 V/7 A)	6EP3333-7LB00-0AX0 (24 V/3.7 A)
Signaling contact		6EP3333-7SB00-0AX0 (24 V/5 A)
LED "O.K.":		
<i>green:</i>	Output voltage $U_{out} > 10$ V or $U_{out} > 11.8$ V	Output voltage $U_{out} > 20$ V or $U_{out} > 23$ V
<i>green flashing (0.5 Hz):</i>	shutdown as a result of thermal overload	shutdown as a result of thermal overload
Signaling contact (13, 14) <i>closed:</i>	Output voltage $U_{out} > 10$ V contact rating: 24 V AC/0.1 A; 30 V DC/0.1 A <b>NOTICE:</b> It is not permissible that the signaling contact is connected on the primary side!	Output voltage $U_{out} > 20$ V contact rating 24 V AC/0.1 A; 30 V DC/0.1 A <b>NOTICE:</b> It is not permissible that the signaling contact is connected on the primary side!

Device with diagnostics monitor

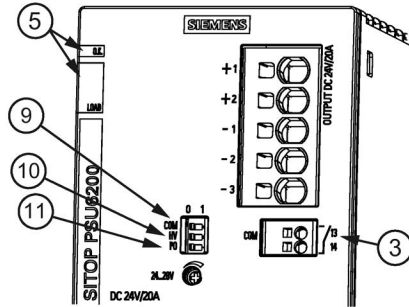
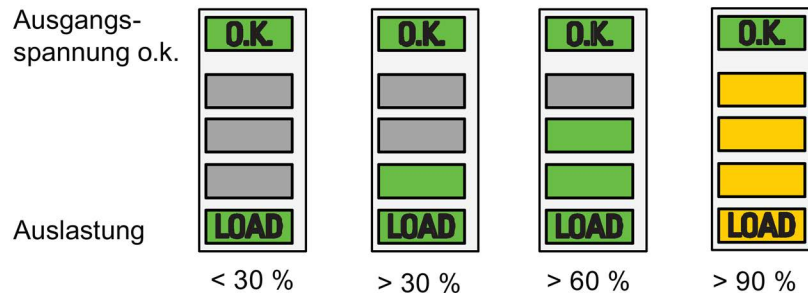

Figure 2-6 Signaling, signaling contact

	6EP3324-7SB00-3AX0 (12 V/12 A)	6EP3334-7SB00-3AX0 (24 V/10 A) 6EP3336-7SB00-3AX0 (24 V/20 A)
<b>Signaling contact</b>		
<b>LED "O.K.":</b>		
<i>green:</i>	Output voltage $U_{out} > 10\text{ V}$ or $U_{out} > 11.8\text{ V}$	Output voltage $U_{out} > 20\text{ V}$ or $U_{out} > 23\text{ V}$
<i>green flashing (0.5 Hz):</i>	shutdown as a result of thermal overload	shutdown as a result of thermal overload
<b>LED "LOAD":</b>		
<i>green:</i>	reached service life $< 90\%$	reached service life $< 90\%$
<i>yellow:</i>	reached service life $\geq 90\%$ ; $I_{out\ rated} \geq 90\%$	reached service life $\geq 90\%$ ; $I_{out\ rated} \geq 90\%$
<b>LEDs above LED "LOAD":</b>		
<i>LED 5.1 green:</i>	$I_{out\ rated} 30 - 60\%$	$I_{out\ rated} 30 - 60\%$
<i>LEDs 5.1+5.2 green:</i>	$I_{out\ rated} 60 - 90\%$	$I_{out\ rated} 60 - 90\%$
<i>LEDs 5.1+5.2+5.3 yellow:</i>	$I_{out\ rated} > 90\%$	$I_{out\ rated} > 90\%$
<b>Contact "COM" (13, 14):</b>	Output voltage $U_{out} > 10\text{ V}$ or $U_{out} > 11.8\text{ V}$ ; data transfer contact rating 24 V AC/0.1 A; 30 V DC/0.1 A	Output voltage $U_{out} > 20\text{ V}$ or $U_{out} > 23\text{ V}$ ; data transfer contact rating 24 V AC/0.1 A; 30 V DC/0.1 A
<i>closed:</i> <i>(for DIP switch COM = 0)</i>	<b>NOTICE:</b> It is not permissible that the contact is connected on the primary side!	<b>NOTICE:</b> It is not permissible that the contact is connected on the primary side!

Diagnostic monitor display:



2.4 Status displays and signaling

Service life < 10 %

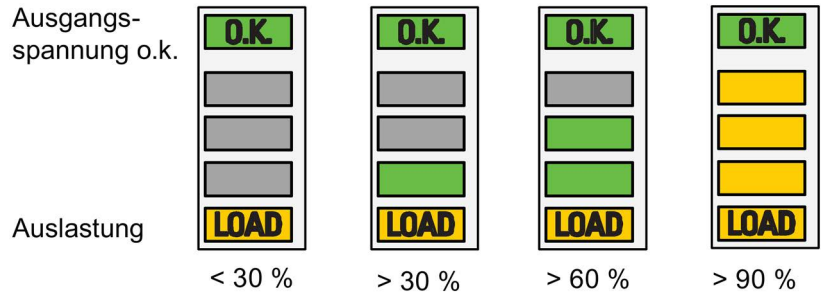

## 2.5 Operating mode

The selection is made using individual DIP switches (when supplied, these are in the 0 position).

It is only permissible to connect two identical devices in parallel to increase the power by changing over the output characteristic by switching selector switch PO ⑪ to 1

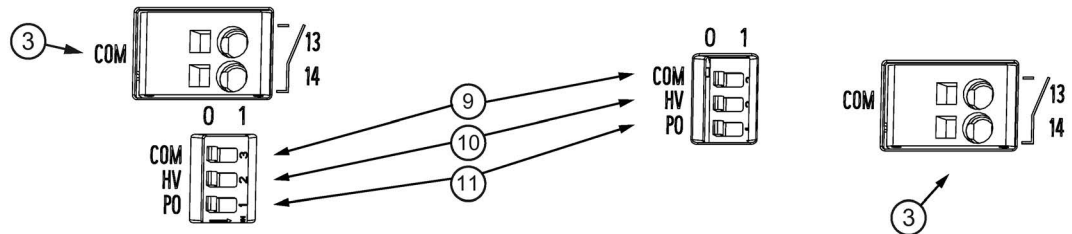

DIP switch	6EP3324-7SB00-3AX0 (12 V/12 A)	6EP3334-7SB00-3AX0 (24 V/10 A) 6EP3336-7SB00-3AX0 (24 V/20 A)
COM ⑨:	Selector switch to toggle between the $U_{out}$ status display and the communication 0: Display of the output voltage status 1: Internal device parameters are transferred via signaling contact (13, 14) (diagnostics interface) <b>CAUTION:</b> It is not permissible that the signaling contact is connected on the primary side! Contact rating: 24 V AC/0.1 A; 30 V DC/0.1 A	
HV ⑩:	Setting, above which value, the "O.K." LED is lit. 0: > 10 V 1: > 11.8 V	Setting, above which the "O.K." LED is lit 0: > 20 V 1: > 23 V
PO ⑪:	Switching over output characteristic 0: Constant output voltage "single operation" 1: Load-dependent output voltage "parallel operation"	

Additional information can be found in the documents:

- Diagnostics interface (<https://support.industry.siemens.com/cs/ww/en/view/109763467>)
- Faceplates and communication blocks (<https://support.industry.siemens.com/cs/ww/en/view/109760217>)

2.6 Block diagram

## 2.6 Block diagram

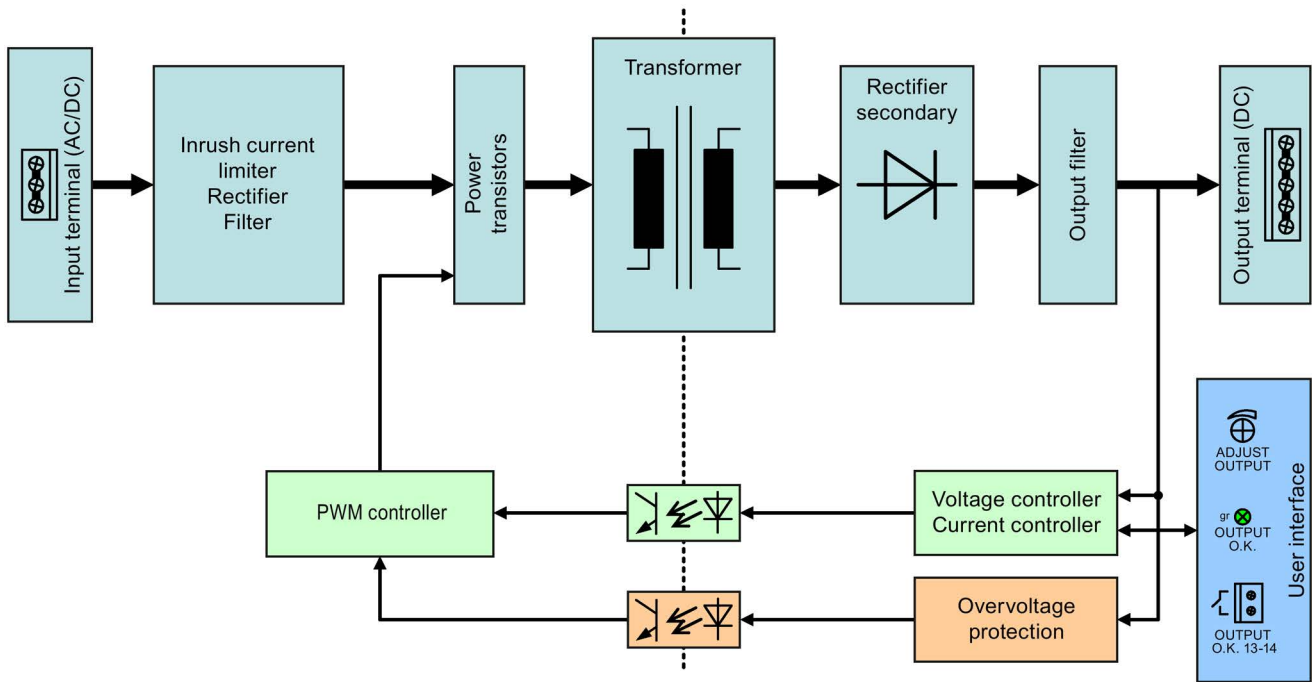

Figure 2-7 Block diagram 3.7/5/7 A

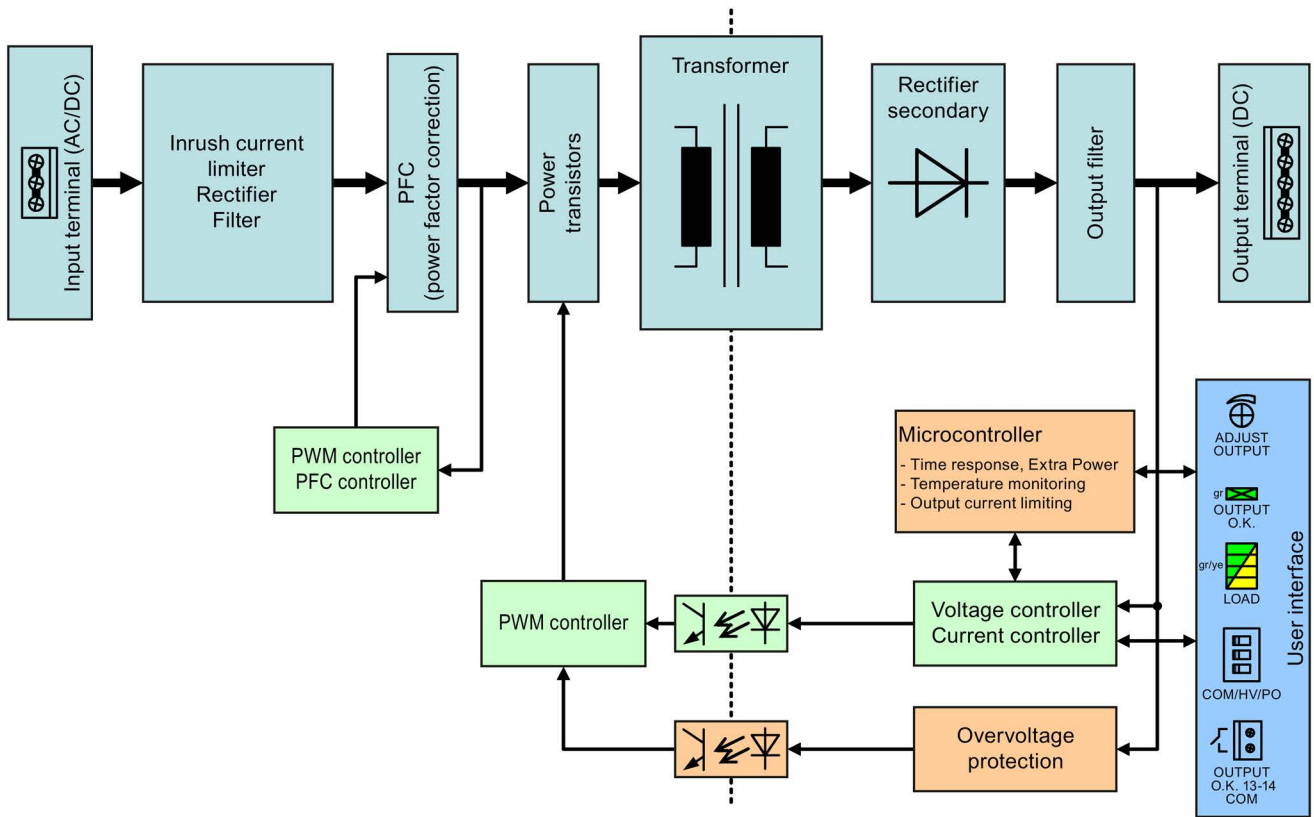

Figure 2-8 Block diagram 10/12/20 A

## 2.7 Dimensions and weight

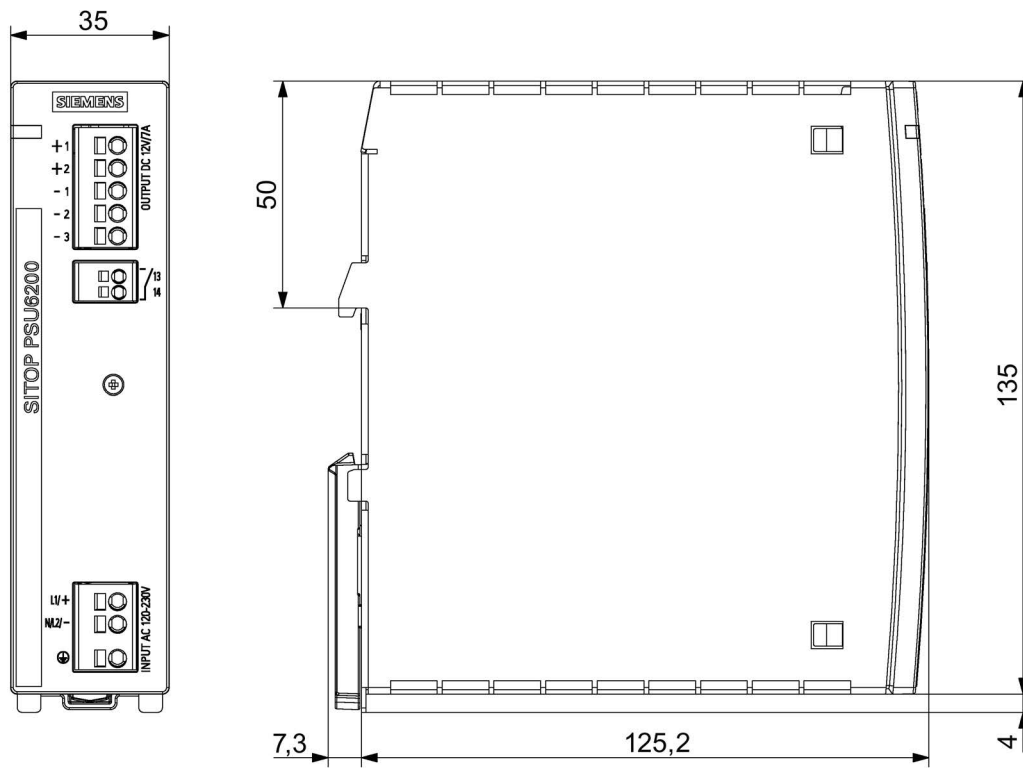

Figure 2-9 Dimension drawing  
6EP3323-7SB00-0AX0  
6EP3333-7LB00-0AX0  
6EP3333-7SB00-0AX0

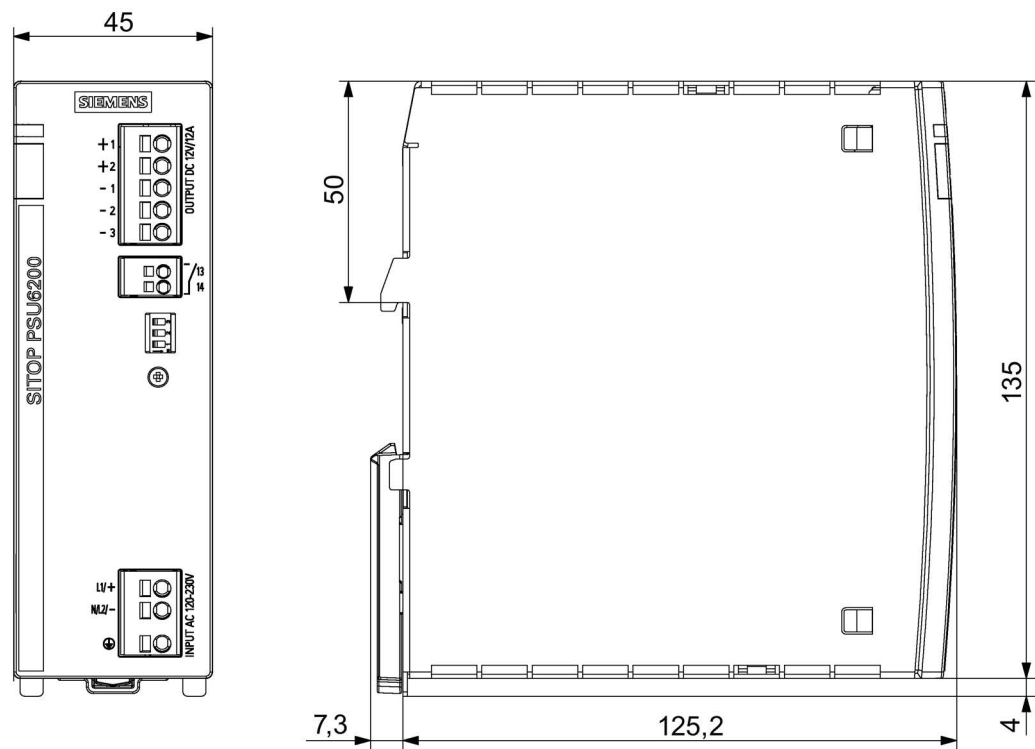

Figure 2-10 Dimension drawing  
6EP3324-7SB00-3AX0  
6EP3334-7SB00-3AX0

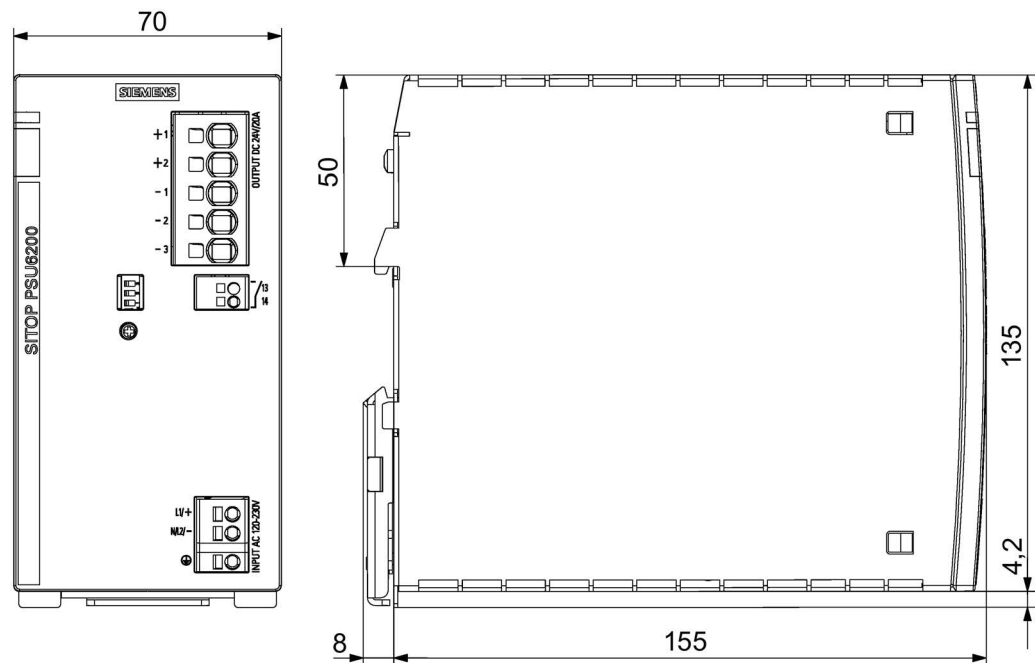

Figure 2-11 Dimension drawing 6EP3336-7SB00-3AX0

2.7 Dimensions and weight

	6EP3323-7SB00-0AX0 (12 V/7 A)	6EP3324-7SB00-3AX0 (12 V/12 A)	6EP3336-7SB00-3AX0 (24 V/20 A)
	6EP3333-7LB00-0AX0 (24 V/3.7 A)	6EP3334-7SB00-3AX0 (24 V/10 A)	
	6EP3333-7SB00-0AX0 (24 V/5 A)		
Dimensions (W × H × D) in mm	35 × 135 × 125	45 × 135 × 125	70 × 135 × 155
Weight	Approx. 0.7 kg	Approx. 0.9 kg	Approx. 1.5 kg

## Mounting/removal

### **⚠ WARNING**

#### **Installing the device in a housing or a control cabinet**

SITOP PSU6200 power supplies are built-in devices. They must be installed in a housing or control cabinet where only qualified personnel have access.

The device can be mounted in a control cabinet on standard mounting rails according to TH35-15/7,5 (EN 60715).

#### **Mounting**

The device must be mounted in such a way that the input terminals are at the bottom and the output terminals at the top. A clearance of at least 45 mm must be maintained above and below the device (max. cable duct depth 50 mm).

#### **Removal**

To remove, pull up the slider ⑥ using a screwdriver and disengage the device at the bottom edge of the standard mounting rail (see Removal diagram). Then you can remove the device from the upper edge of the standard mounting rail.

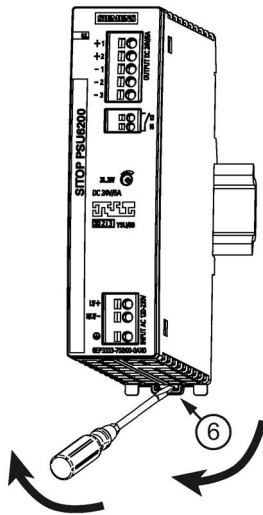

Figure 3-1 Mounting/removal



## Mounting position, mounting clearances

### 4.1 Standard mounting position

The device is mounted on standard mounting rails according to EN 60715 35x7,5/15. The device must be mounted vertically in such a way that the input terminals are at the bottom and the output terminals are at the top to ensure correct cooling.

A clearance of at least 45 mm must always be maintained above and below the device (max. cable channel depth, 50 mm).

Lateral clearances do not have to be maintained.

### Output current as a function of the ambient temperature and mounting height

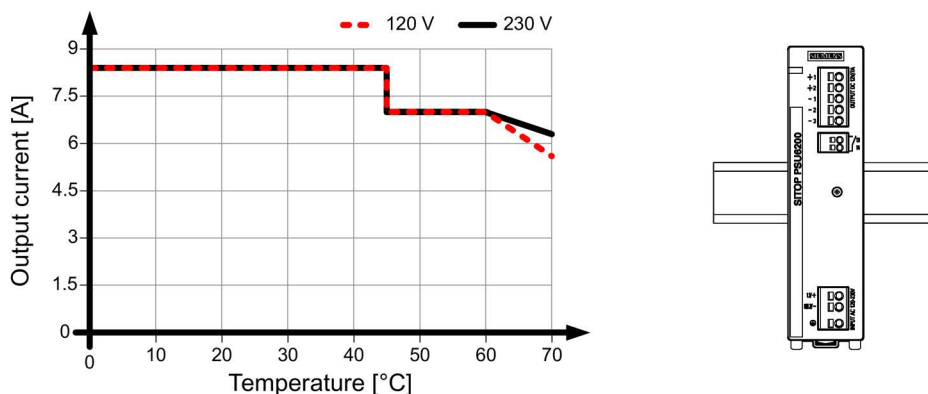

Figure 4-1 6EP3323-7SB00-0AX0 output current in the standard mounting position

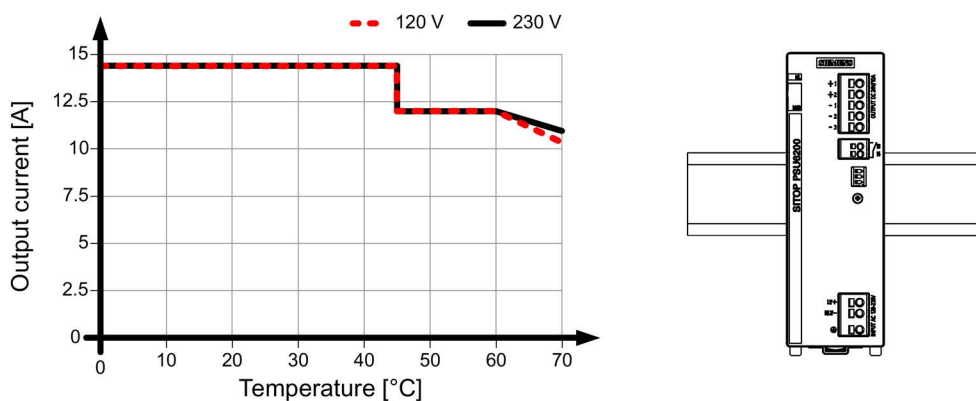

Figure 4-2 6EP3324-7SB00-3AX0 output current in the standard mounting position

4.1 Standard mounting position

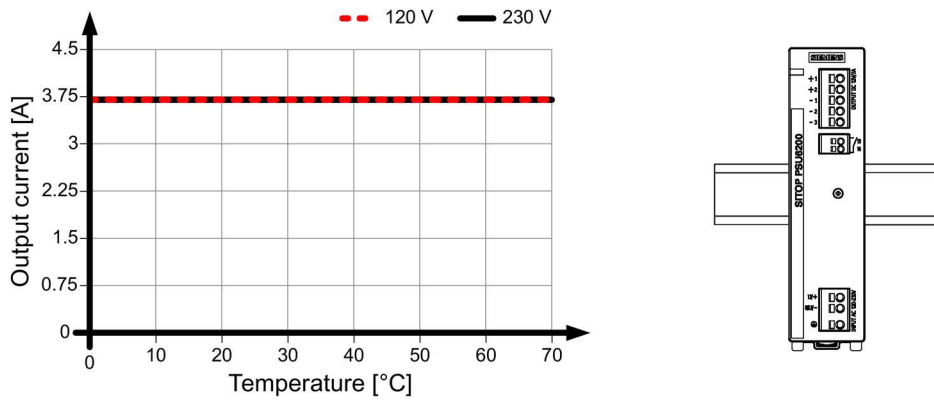

Figure 4-3 6EP3333-7LB00-0AX0 output current in the standard mounting position

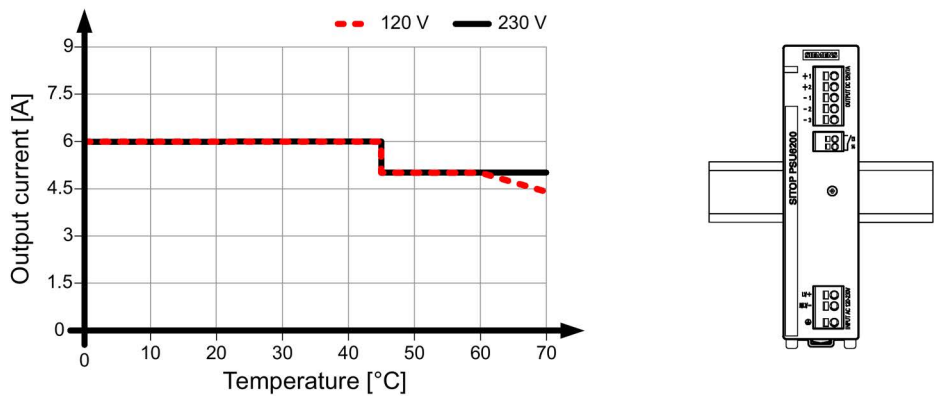

Figure 4-4 6EP3333-7SB00-0AX0 output current in the standard mounting position

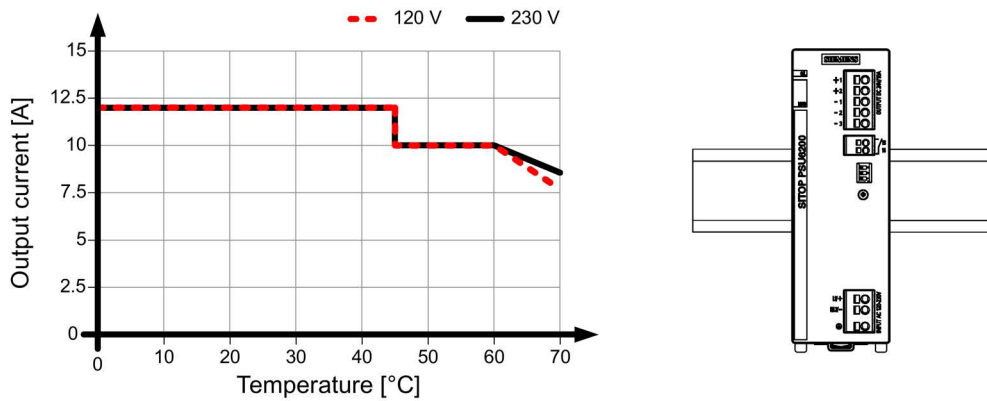

Figure 4-5 6EP3334-7SB00-3AX0 output current in the standard mounting position

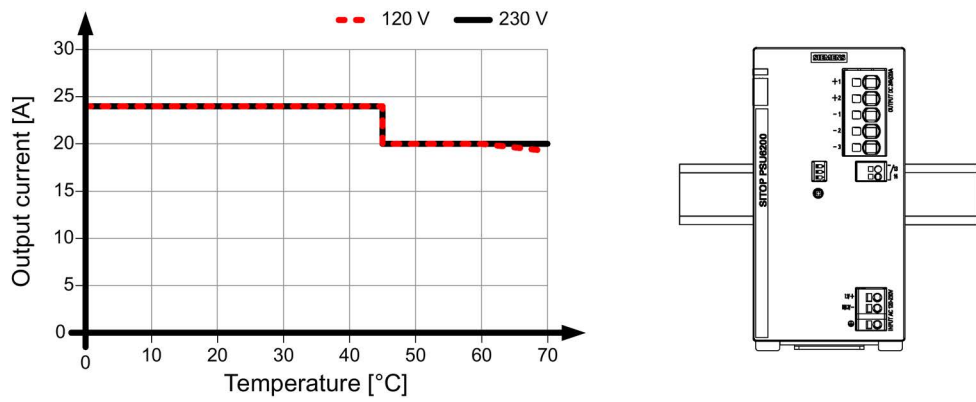

Figure 4-6 6EP3336-7SB00-3AX0 output current in the standard mounting position

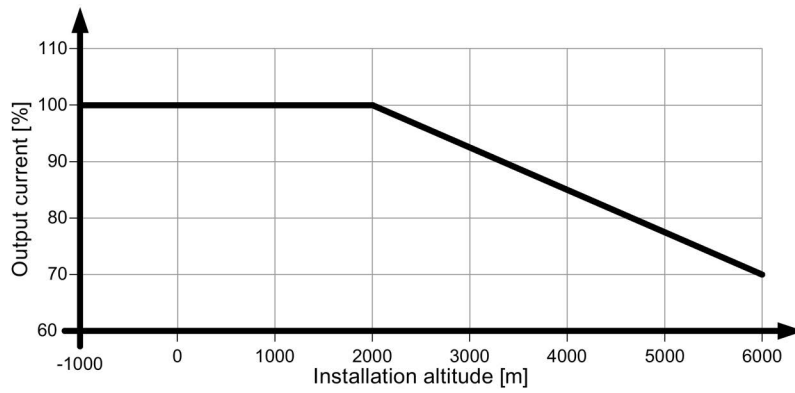

Figure 4-7 Mounting height derating

Details see chapter Ambient conditions (Page 65)

## 4.2 Other mounting positions

For mounting positions that deviate from the standard mounting position, derating factors (reduction of the output power or the permissible ambient temperature) must be observed in accordance with the following diagrams.

### Note

In the case of mounting positions that deviate from the standard mounting position, reduced mechanical resistance of the devices against vibration and shock must be expected.

Particularly when installing on a vertically fastened standard mounting rail, additional measures may be required, e.g. to prevent the device from slipping on the standard mounting rail.

### 4.2.1 6EP3323-7SB00-0AX0

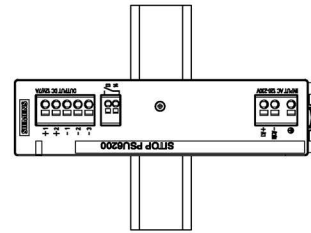
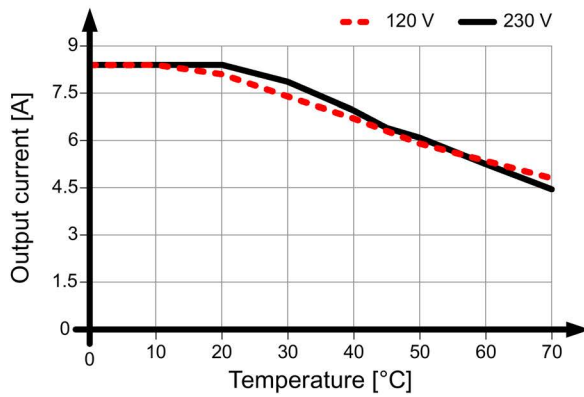

Figure 4-8 6EP3323-7SB00-0AX0 mounting position 1

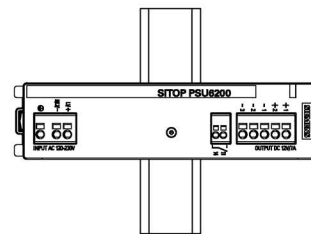
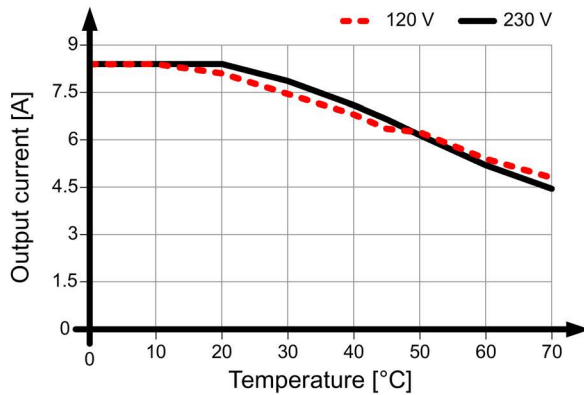

Figure 4-9 6EP3323-7SB00-0AX0 mounting position 2

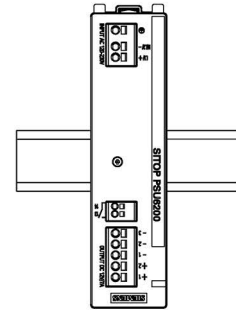
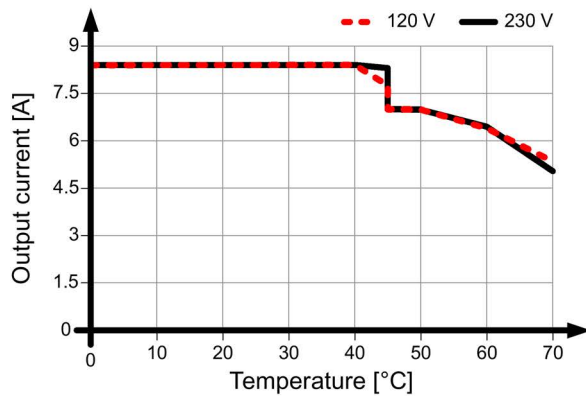

Figure 4-10 6EP3323-7SB00-0AX0 mounting position 3

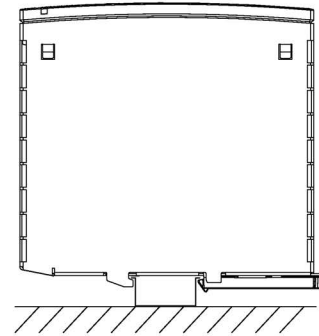
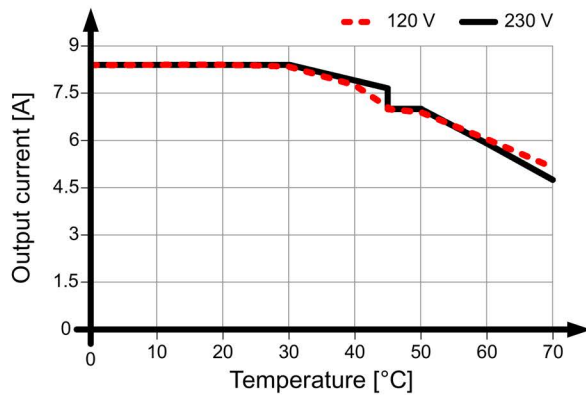

Figure 4-11 6EP3323-7SB00-0AX0 mounting position 4

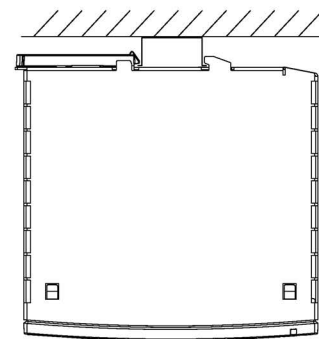
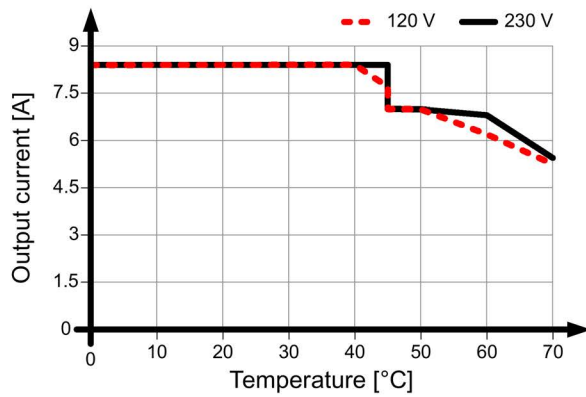

Figure 4-12 6EP3323-7SB00-0AX0 mounting position 5

4.2.2 6EP3324-7SB00-3AX0

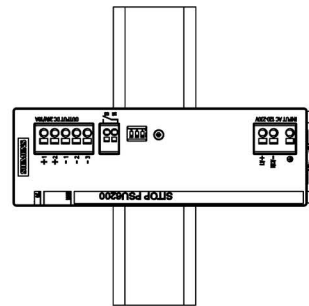
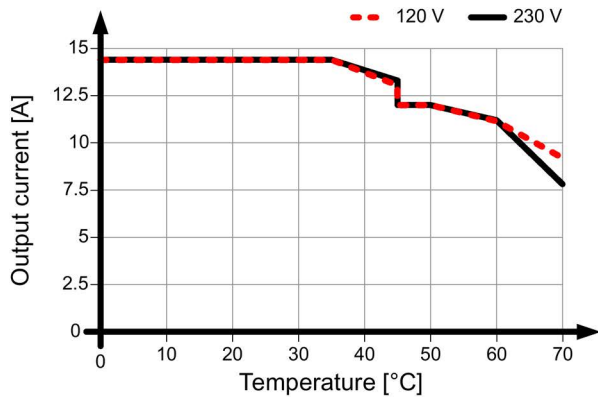

Figure 4-13 6EP3324-7SB00-3AX0 mounting position 1

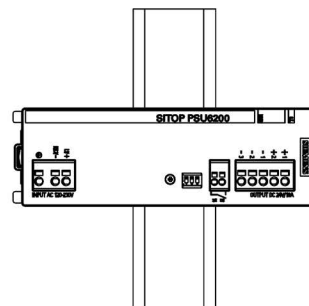
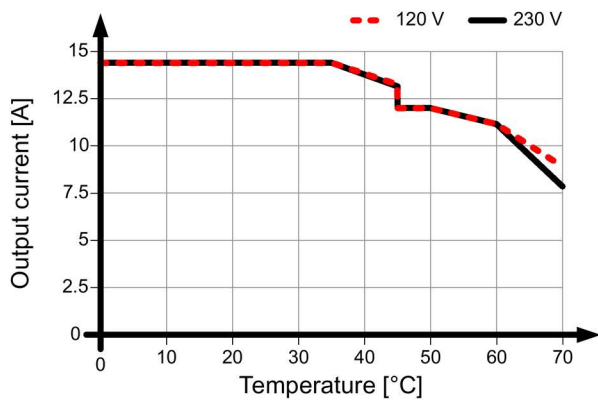

Figure 4-14 6EP3324-7SB00-3AX0 mounting position 2

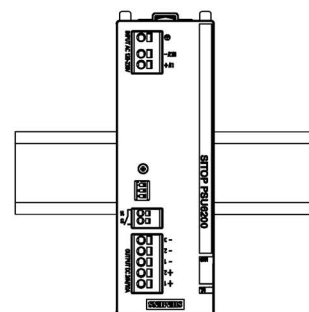
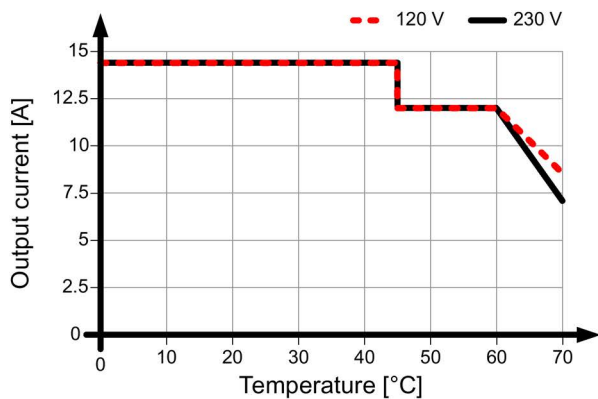

Figure 4-15 6EP3324-7SB00-3AX0 mounting position 3

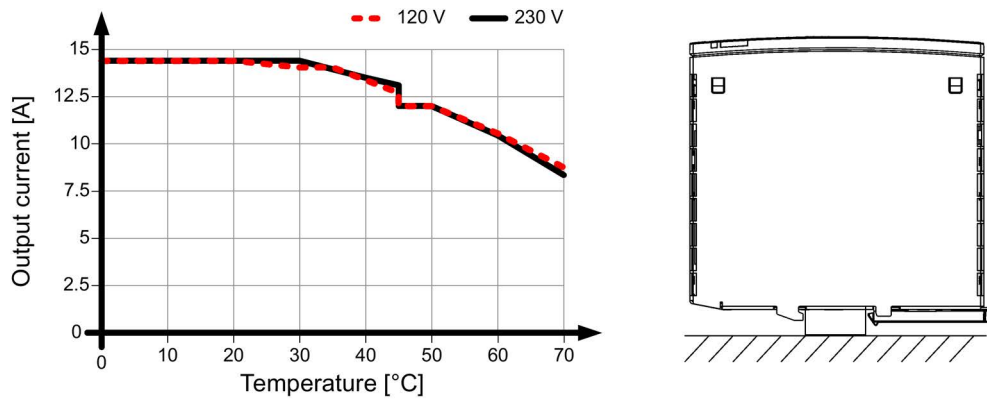

Figure 4-16 6EP3324-7SB00-3AX0 mounting position 4

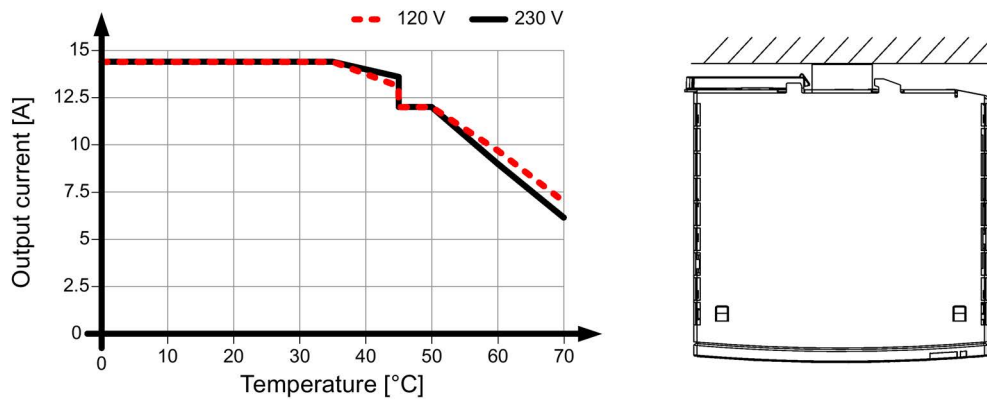

Figure 4-17 6EP3324-7SB00-3AX0 mounting position 5

4.2 Other mounting positions

4.2.3 6EP3333-7LB00-0AX0

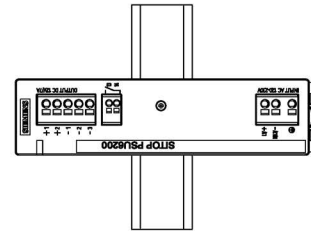
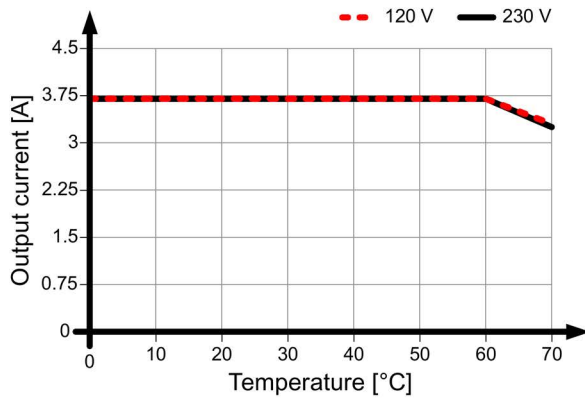

Figure 4-18 6EP3333-7LB00-0AX0 mounting position 1

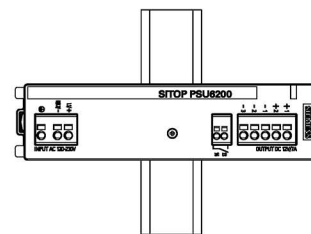
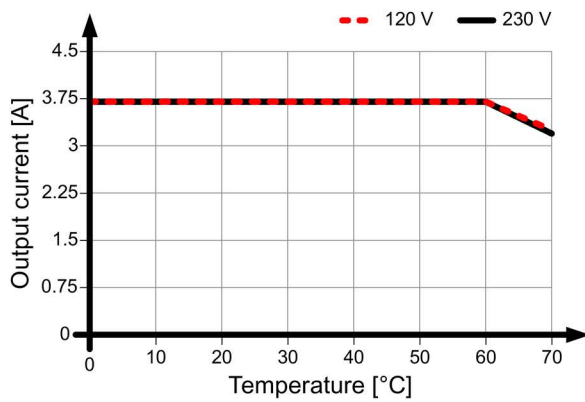

Figure 4-19 6EP3333-7LB00-0AX0 mounting position 2

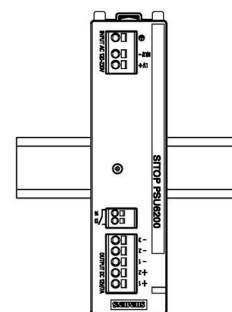
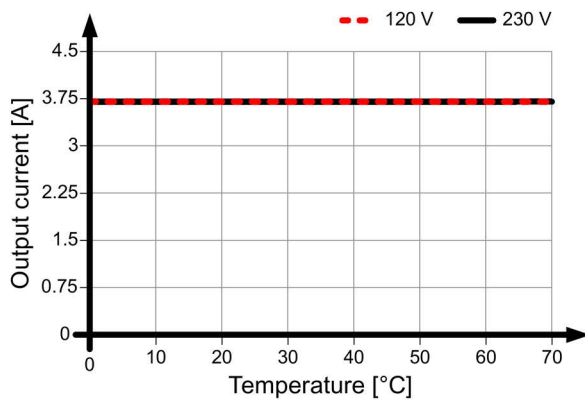

Figure 4-20 6EP3333-7LB00-0AX0 mounting position 3

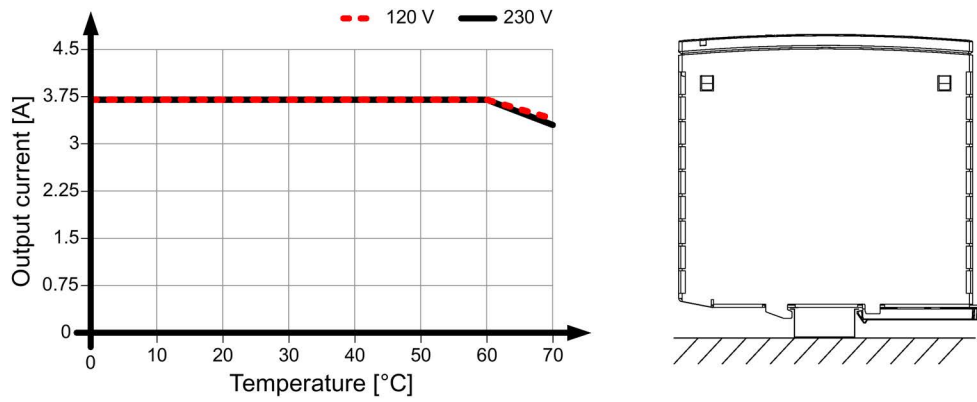

Figure 4-21 6EP3333-7LB00-0AX0 mounting position 4

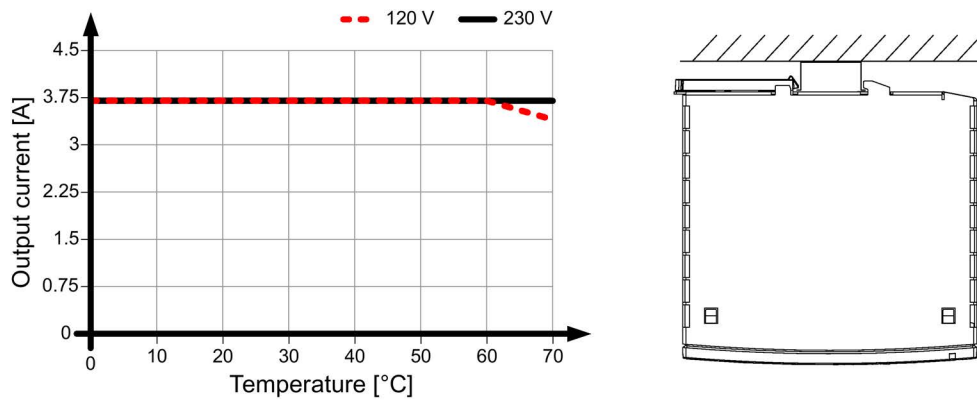

Figure 4-22 6EP3333-7LB00-0AX0 mounting position 5

4.2.4 6EP3333-7SB00-0AX0

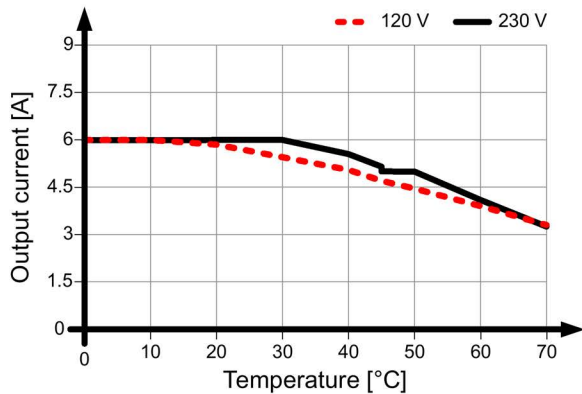

Figure 4-23 6EP3333-7SB00-0AX0 mounting position 1

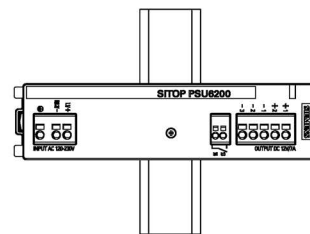
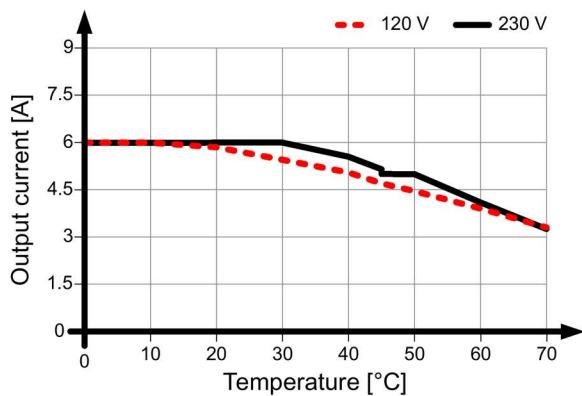

Figure 4-24 6EP3333-7SB00-0AX0 mounting position 2

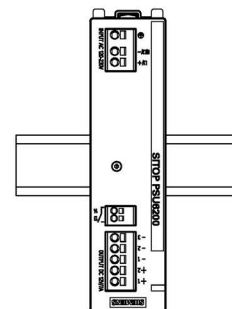
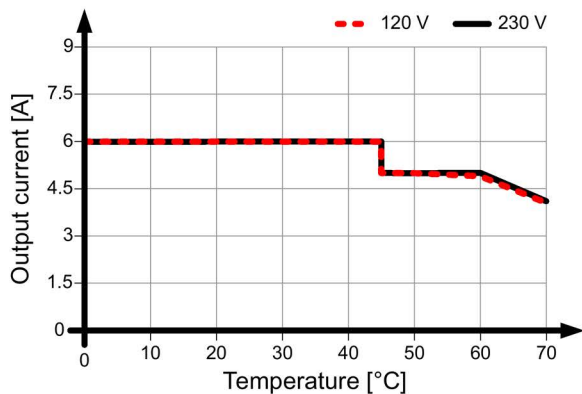

Figure 4-25 6EP3333-7SB00-0AX0 mounting position 3

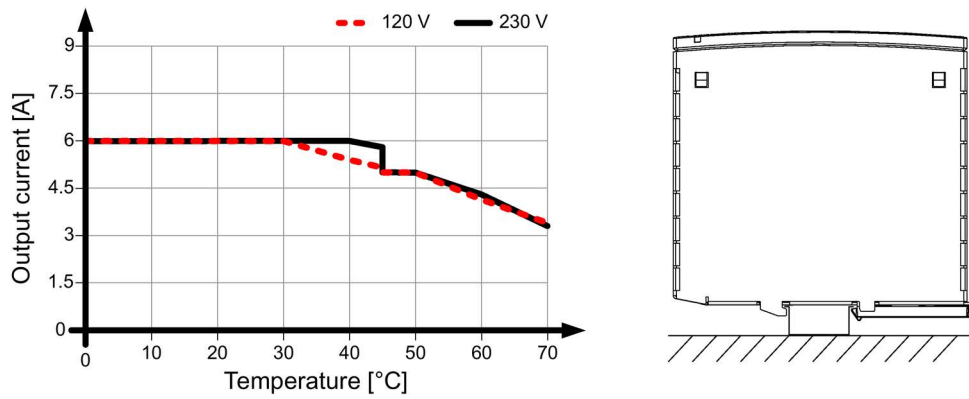

Figure 4-26 6EP3333-7SB00-0AX0 mounting position 4

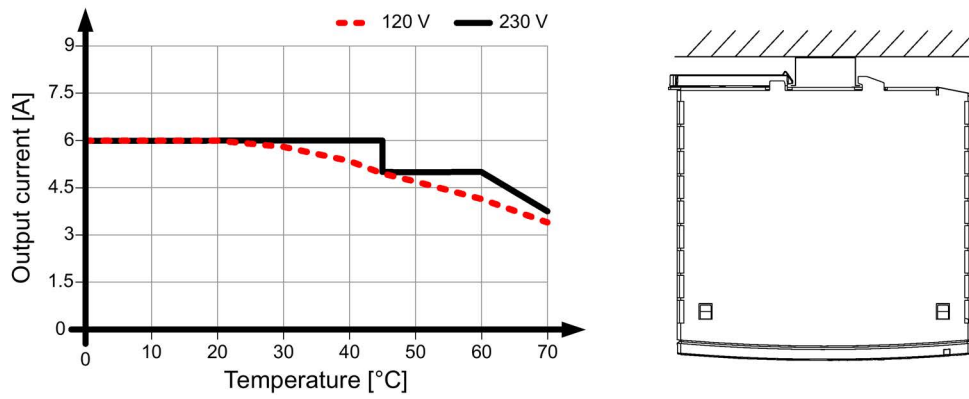

Figure 4-27 6EP3333-7SB00-0AX0 mounting position 5

4.2 Other mounting positions

4.2.5 6EP3334-7SB00-3AX0

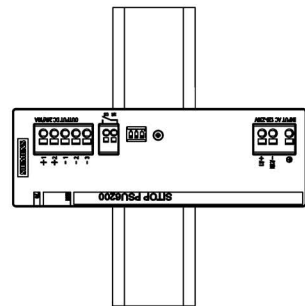
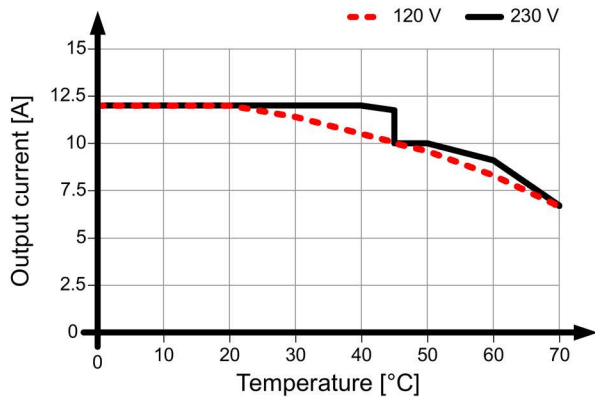

Figure 4-28 6EP3334-7SB00-3AX0 mounting position 1

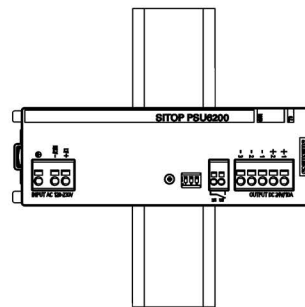
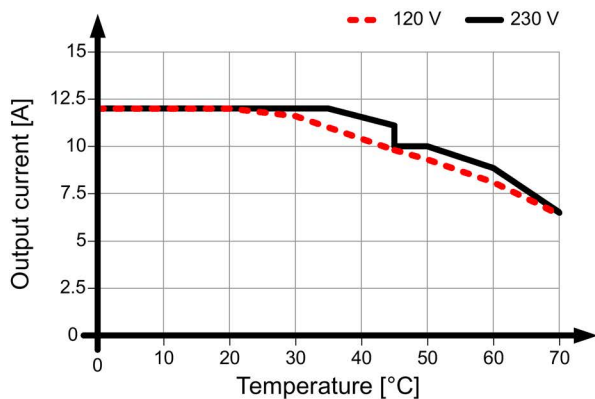

Figure 4-29 6EP3334-7SB00-3AX0 mounting position 2

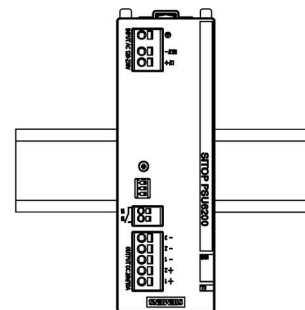
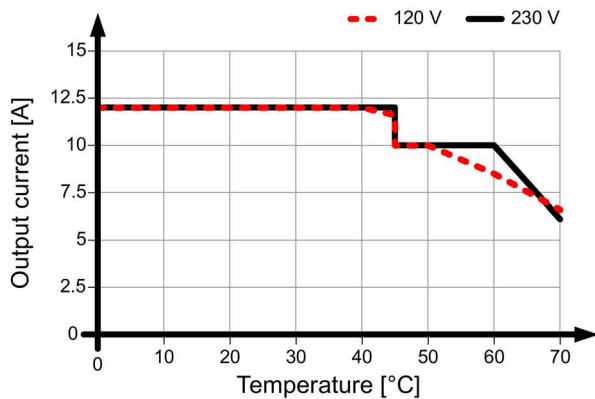

Figure 4-30 6EP3334-7SB00-3AX0 mounting position 3

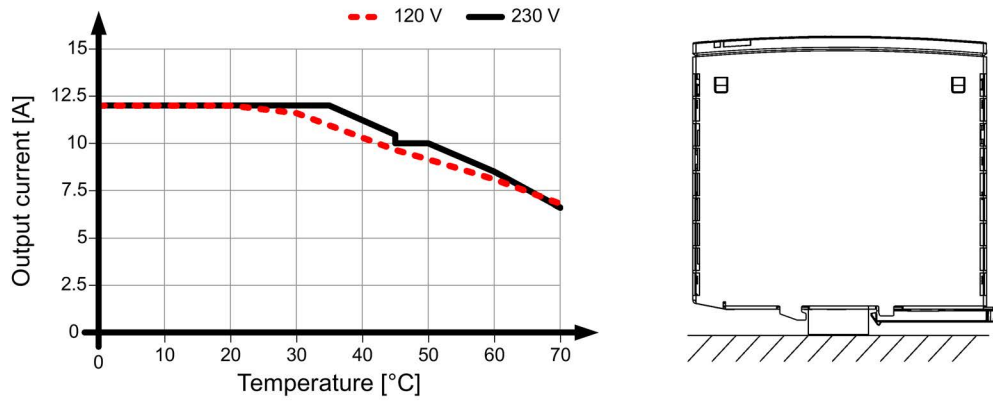

Figure 4-31 6EP3334-7SB00-3AX0 mounting position 4

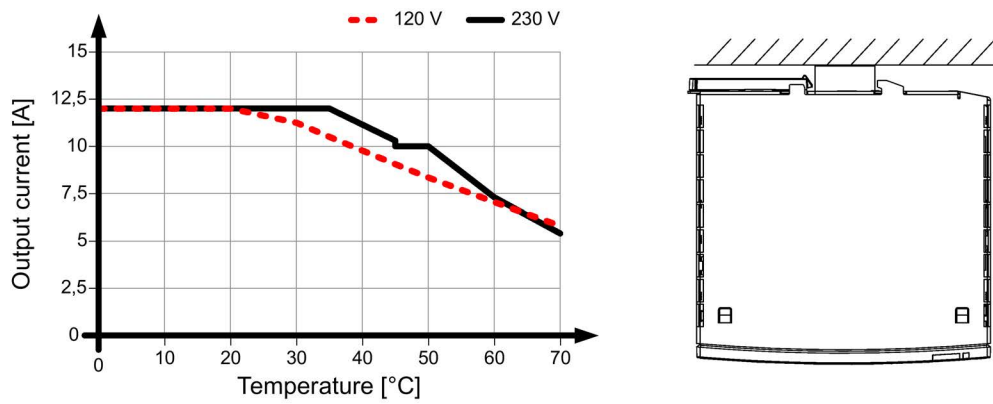

Figure 4-32 6EP3334-7SB00-3AX0 mounting position 5

4.2.6 6EP3336-7SB00-3AX0

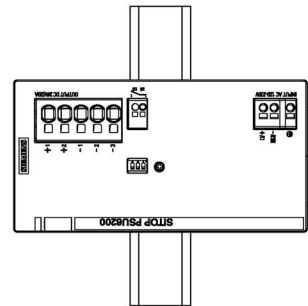
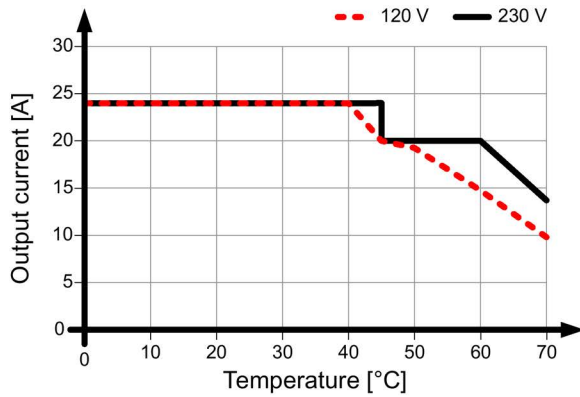

Figure 4-33 6EP3336-7SB00-3AX0 mounting position 1

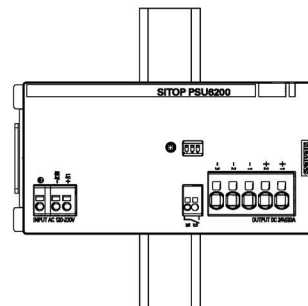
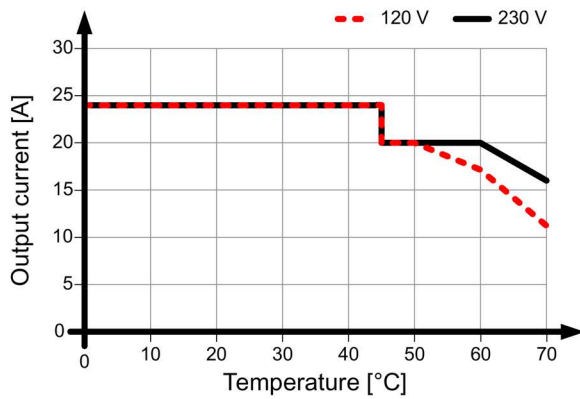

Figure 4-34 6EP3336-7SB00-3AX0 mounting position 2

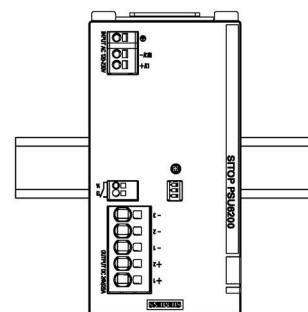
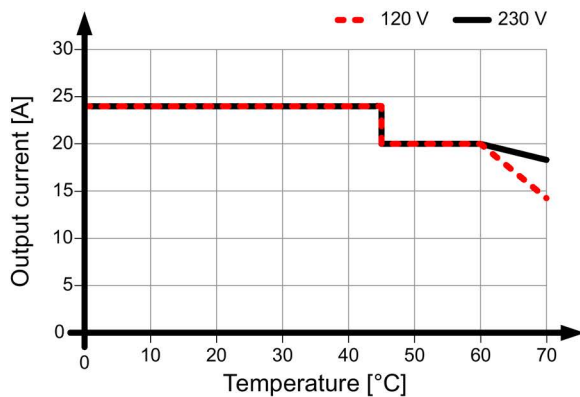

Figure 4-35 6EP3336-7SB00-3AX0 mounting position 3

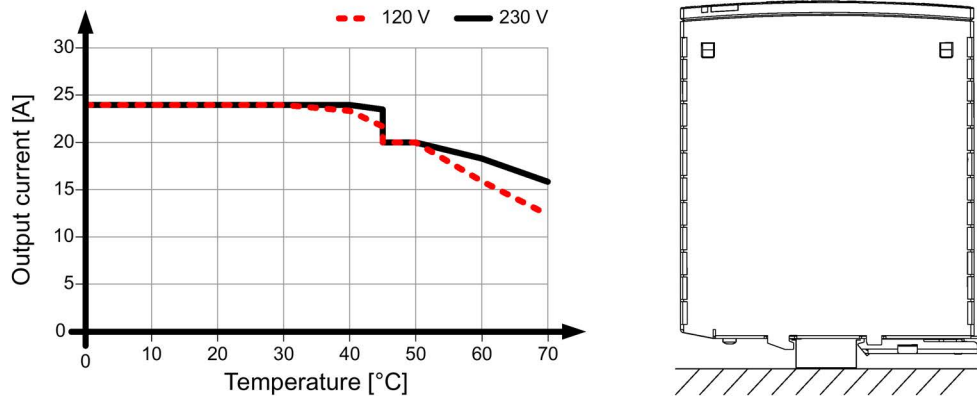

Figure 4-36 6EP3336-7SB00-3AX0 mounting position 4

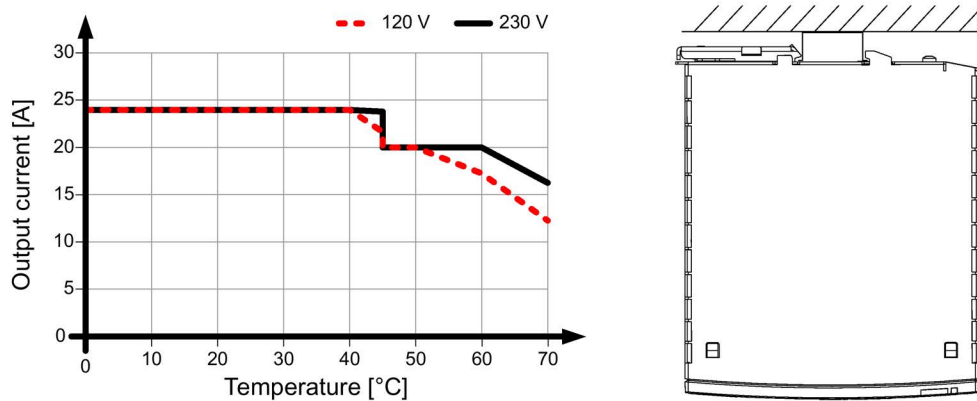

Figure 4-37 6EP3336-7SB00-3AX0 mounting position 5

*4.2 Other mounting positions*

## Installation

<p><b>⚠ WARNING</b></p> <p><b>Hazard due to electric shock</b></p> <p>Before installation or maintenance work can begin, the system's main switch must be switched off and measures taken to prevent it being switched on again. If this instruction is not observed, touching live parts can result in death or serious injury.</p>
--

### 5.1 Line-side connection

SITOP PSU6200 power supplies are designed for connection to a 1-phase AC line supply (TN-, TT or IT line supply according to IEC 60364-1 with rated voltage 120 - 230 V AC, 50 - 60 Hz or a DC power supply with 120 V - 240 V DC (3.7 A/24 V, 5 A/24 V, 7 A/12 V) or 110 V - 240 V DC (10 A/24 V, 12 A/12 V)



Figure 5-1 Line-side connection

The line supply is connected using terminal L1, N (L2) and PE (see Figure 5-1 Line-side connection (Page 39)), and must be implemented according to IEC 60364 and EN 50178 . A protective device (miniature circuit breaker or circuit breaker) and a disconnection unit for the power supply must be provided. A ground-fault circuit interrupter is not permissible against indirect contact as the only protective measure. This is true for the complete line supply protected by the ground-fault circuit interrupter.

#### Protection

SITOP PSU6200	Recommended line-side protection
6EP3323-7SB00-0AX0 (12 V/7 A) 6EP3324-7SB00-3AX0 (12 V/12 A) 6EP3333-7LB00-0AX0 (24 V/3.7 A) 6EP3333-7SB00-0AX0 (24 V/5 A)	Miniature circuit breaker (IEC 898) characteristic C, 6 A
6EP3334-7SB00-3AX0 (24 V/10 A) 6EP3336-7SB00-3AX0 (24 V/20 A)	Miniature circuit breaker (IEC 898) characteristic C, 10 A

The protective conductor of the line supply must be connected at the PE terminal.

*5.1 Line-side connection*

Other country-specific regulations may have to be observed when installing the device.

---

**Note**

For operation on a DC power system (DC), the plus pole (+) must be connected to L1 and the minus pole (–) to N.

---

## 5.2 Output-side connection

SITOP PSU6200 power supplies provide at their outputs an isolated (= non-grounded) SELV output voltage (Safety Extra Low Voltage). The output of the power supply is no-load, overload, and short-circuit proof. If an overload occurs, the electronic current limitation limits the output current to a maximum value (refer to chapter Technical data (Page 43)).

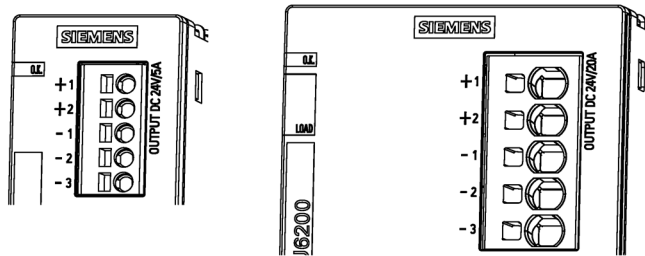

Figure 5-2 Output-side connection

The output voltage is connected via the "+" and "-" terminals at the output of the power supply (see Fig. Figure Output-side connection (Page 41)). Ensure that the output cables are dimensioned correctly for the maximum output current rms value and fused accordingly.

The subsequent digit, e.g.: "+1" designates the unique terminal connection, therefore simplifying correct wiring.

### Note

If the safety concept of the plant or system specifies that the DC output circuit should be grounded (PELV), then it is permissible that the output voltage of the SITOP power supply is grounded. In this case, ideally, the grounding at the output should be directly connected from terminal "-" of the power supply to a suitable connection point of the protective conductor system (PE) of the plant or system.



## Technical data

### Note

Technical data apply for a rated input voltage, rated load and 25 °C ambient temperature if nothing else is specified.

### 6.1 Input

	6EP3323-7SB00-0AX0 (12 V/7 A)	6EP3324-7SB00-3AX0 (12 V/12 A)
Rated voltage $U_{in \text{ rated}}$	AC: 120 V - 230 V; DC: 120 V - 240 V	AC: 120 V - 230 V; DC: 110 V - 240 V
Voltage range	AC: 85 V - 264 V; DC: 99 V - 275 V	AC: 85 V - 264 V; DC: 85 V - 275 V
• Remark	Derating at $U_{in} < 102 \text{ V AC}$ : max. 80 % $I_{out \text{ rated}}$	-
Wide-range input	Yes	
Connect/shutdown threshold, typical	81 V AC / 49 V AC	83 V AC / 58 V AC
Line supply buffering at $I_{out \text{ rated}}$ , min	20 ms	20 ms
Power-failure buffering	at 120 V / 230 V	
Rated line frequency	50 - 60 Hz	
Line frequency range	47 - 63 Hz	
Input current at the rated input voltage of 120 V	1.5 A AC / 0.9 A DC	1.3 A AC / 1.4 A DC
Input current at rated input voltage 230 V	0.9 A AC / 0.5 A DC	0.8 A AC / 0.7 A DC
Inrush current limiting (25 °C), max.	29 A	6 A
$I^2t$ , at 120 V AC, max.	0.4 A <sup>2</sup> s	1 A <sup>2</sup> s
$I^2t$ , at 230 V AC, max.	1.3 A <sup>2</sup> s	0.5 A <sup>2</sup> s
Integrated input fuse	Fuse T 3.15 A	Fuse T 6 A
Protection in the line feeder cable (IEC 898)	Recommended: Miniature circuit breaker characteristic C, 6 A	Recommended: Circuit breaker, C characteristic, 6 A
Power consumption (active power) at full load	100 W	97 W
Overvoltage strength	300 V AC for 30 seconds	

## Technical data

### 6.1 Input

	6EP3333-7LB00-0AX0 (24 V/3.7 A)	6EP3333-7SB00-0AX0 (24 V/5 A)	6EP3334-7SB00-3AX0 (24 V/10 A)	6EP3336-7SB00-3AX0 (24 V/20 A)
Rated voltage $U_{in \text{ rated}}$	AC: 120 V - 230 V; DC: 120 V - 240 V		AC: 120 V - 230 V; DC: 110 V - 240 V	
Voltage range	AC: 85 V - 264 V; DC: 99 V - 275 V	AC: 85 V - 264 V; DC: 99 V - 275 V	AC: 85 V - 264 V; DC: 85 V - 275 V	AC: 85 V - 264 V; DC: 85 V - 275 V
• Remark	-	Derating at $U_{in} < 102 \text{ V}$ AC: max. 80 % $I_{out \text{ rated}}$	Derating at $U_{in} < 102 \text{ V}$ AC: max. 80 % $I_{out \text{ rated}}$	Derating at $U_{in} < 102 \text{ V}$ AC: max. 90 % $I_{out \text{ rated}}$
Wide-range input	Yes			
Connect/shutdown threshold, typical	82 V / 51 V	83 V / 53 V	83 V / 74 V	83 V/74 V
Line failure buffering at $I_{out \text{ rated}}$ , min	20 ms	20 ms	20 ms	20 ms
Power-failure buffering	at 120 / 230 V			
Rated line frequency	50 - 60 Hz			
Line frequency range	47 - 63 Hz			
Input current at rated input voltage 120 V	1.5 A AC / 0.9 A DC	1.9 A AC / 1.1 A DC	2.2 A AC / 2.2 A DC	4.4 A AC / 4.8 A DC
Input current at rated input voltage 230 V	0.9 A AC / 0.5 A DC	1.2 A AC / 0.6 A DC	1.2 A AC / 1.1 A DC	2.3 A AC / 2.2 A DC
Inrush current limiting (25 °C), max.	29 A	30 A	6 A	12 A
$I^2t$ , at 120 V AC, max.	0.4 A <sup>2</sup> s	0.4 A <sup>2</sup> s	1 A <sup>2</sup> s	4 A <sup>2</sup> s
$I^2t$ , at 230 V AC, max.	1.3 A <sup>2</sup> s	1.3 A <sup>2</sup> s	0.6 A <sup>2</sup> s	1.4 A <sup>2</sup> s
Integrated input fuse	Fuse T 3.15 A	Fuse T 3.15 A	Fuse T 6 A	Fuse T 10 A
Protection in the line feeder cable (IEC 898)	Recommended: Miniature circuit breaker characteristic C, 6 A	Recommended: Circuit breaker, C characteristic, 6 A	Recommended: Miniature circuit breaker characteristic C, 10 A	Recommended: Miniature circuit breaker characteristic C, 10 A
Power consumption (active power) at full load	100 W	133 W	260 W	500 W
Overvoltage strength	300 V AC for 30 seconds			

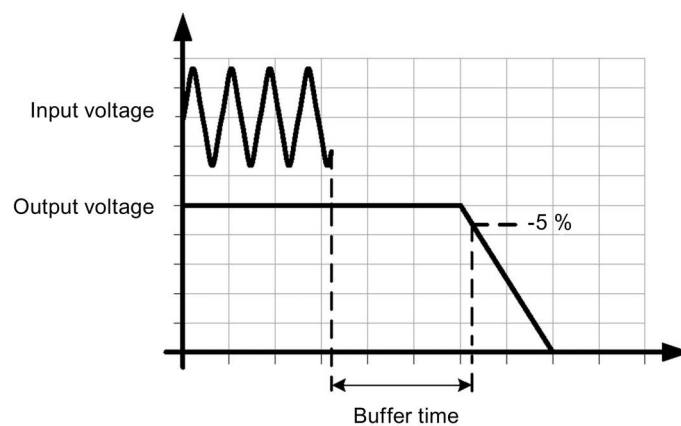

Figure 6-1 Power-failure buffering

## 6.2 Output

	6EP3323-7SB00-0AX0 (12 V/7 A)	6EP3324-7SB00-3AX0 (12 V/12 A)
Output	Regulated, isolated DC voltage	
Rated voltage $U_{out\ rated\ DC}$	12 V	
Total tolerance, static $\pm$	3 %	3 %
Static line regulation, approx. $\pm$	0.1 %	0.1 %
Static load regulation, approx. $\pm$	1 %	1 %
Residual ripple Peak-peak, max.	150 mV	150 mV
Spikes peak-peak, max. (bandwidth, 200 MHz)	240 mV	240 mV
Adjustment range	12 - 15.5 V	
Output voltage can be adjusted	Yes	
Output voltage setting	Using a potentiometer	
Status display	LED green for 12 V O.K.	LED green for 12 V O.K., diagnostics monitor, see Chapter Status displays and signaling (Page 12)
Signaling	Relay contact (NO contact, contact rating 60 V DC/0.3 A) for 12 V O.K.	
Response when switching on/off	Overshoot of $U_{out} < 100\text{ mV}$	
Starting delay, max.	90 ms	310 ms
Start delay, typ.	30 ms	140 ms
Voltage rise 120 V / 230 V AC max.	50 ms	100 ms
Voltage rise 120 V / 230 V AC typ.	30 ms	80 ms
Rated current $I_{out\ rated}$	7 A	12 A
Current range	0 ... 7 A	0 ... 12 A
• Remark	8.4 A to 45 °C 60 ... 70 °C derating: 3 % $I_{out\ rated}/K$	14.4 A to 45 °C 60 ... 70 °C derating: 3 % $I_{out\ rated}/K$
Active power output, typ.	84 W	146 W
Overload capability (Extra Power)	10.5 A for 5 s/min	18 A for 5 s/min
Can be connected in parallel to increase the power rating	No	Yes
Number of devices that can be connected in parallel to increase the power rating, units	-	2
Output characteristic	see Figure 6-3 Output characteristic 6EP3323-7SB00-0AX0 single operation (Page 48)	see Figure 6-4 Output characteristic 6EP3324-7SB00-3AX0 single operation (Page 49)
Capacitive load, max.	2 mF/A	

	6EP3333-7LB00-0AX0 (24 V/3.7 A)	6EP3333-7SB00-0AX0 (24 V/5 A)	6EP3334-7SB00-3AX0 (24 V/10 A)	6EP3336-7SB00-3AX0 (24 V/20 A)
Output	Regulated, isolated DC voltage			
Rated voltage $U_{out\ rated}$ DC	24 V			
Total tolerance, static $\pm$	3 %	3 %	3 %	3 %
Static line regulation, approx. $\pm$	0.1 %	0.1 %	0.1 %	0.5 %
Static load regulation, approx. $\pm$	1 %	1 %	1 %	1 %
Residual ripple Peak-peak, max.	150 mV	150 mV	150 mV	150 mV
Spikes peak-peak, max. (bandwidth, 200 MHz)	240 mV	240 mV	240 mV	240 mV
Adjustment range	24 V - 28 V			
Output voltage can be adjusted	Yes			
Output voltage setting	Using a potentiometer			
Status display	LED green for 24 V O.K.		LED green for 24 V O.K., diagnostics monitor, see Chapter Status displays and signaling (Page 12)	LED green for 24 V O.K., diagnostics monitor, see Chapter Status displays and signaling (Page 12)
Signaling	Relay contact (NO contact, contact rating 60 V DC/0.3 A) for 24 V O.K.			
Response when switching on/off	Overshoot of $U_{out} < 100$ mV			Overshoot of $U_{out} < 520$ mV
Starting delay, max.	90 ms	90 ms	310 ms	230 ms
Start delay, typ.	30 ms	30 ms	140 ms	80 ms
Voltage rise 120 V / 230 V AC max.	150 ms	100 ms	200 ms	100 ms
Voltage rise 120 V / 230 V AC typ.	130 ms	50 ms	180 ms	80 ms
Rated current $I_{out\ rated}$	3.7 A	5 A	10 A	20 A
Current range	0 ... 3.7 A	0 ... 5 A	0 ... 10 A	0 ... 20 A
• Remark		6 A to 45 °C 60 ... 70 °C derating: 3 % $I_{out\ rated}/K$	12 A to 45 °C 60 ... 70 °C derating: 3 % $I_{out\ rated}/K$	24 A to 45 °C 60 ... 70 °C derating: 3 % $I_{out\ rated}/K$
Active power output, typ.	89 W	120 W	240 W	480 W
Overload capability (Extra Power)	-	7.5 A for 5 s/min	15 A for 5 s/min	30 A for 5 s/min

6.2 Output

	6EP3333-7LB00-0AX0 (24 V/3.7 A)	6EP3333-7SB00-0AX0 (24 V/5 A)	6EP3334-7SB00-3AX0 (24 V/10 A)	6EP3336-7SB00-3AX0 (24 V/20 A)
Can be connected in parallel to increase the power rating	No	No	Yes	Yes
Number of devices that can be connected in parallel to increase the power rating, units	-	-	2	2
Output characteristic	see Figure 6-5 Output characteristic 6EP3333-7LB00-0AX0 single operation (Page 49)	see Figure 6-6 Output characteristic 6EP3333-7SB00-0AX0 single operation (Page 49)	see Figure 6-7 Output characteristic 6EP3334-7SB00-3AX0 single operation (Page 50)	see Figure 6-8 Output characteristic 6EP3336-7SB00-3AX0 single operation (Page 50)
Capacitive load, max.	2 mF/A			

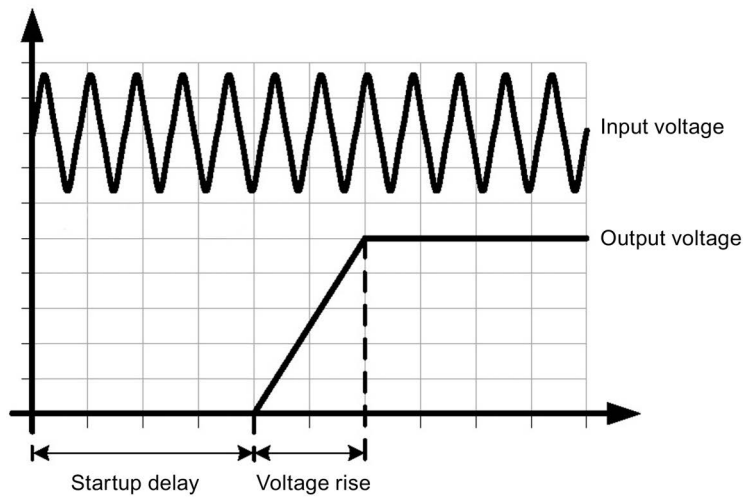

Figure 6-2 Startup delay/voltage rise

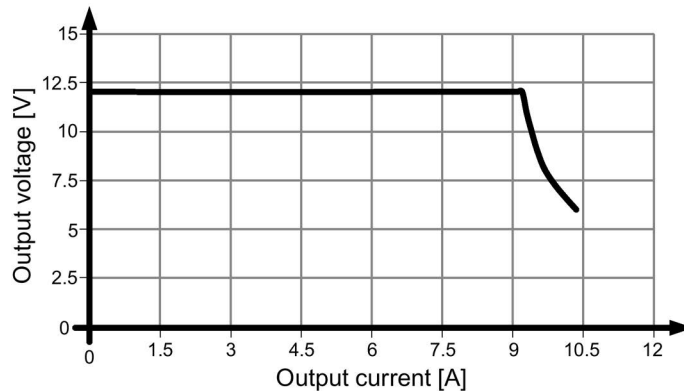

Figure 6-3 Output characteristic 6EP3323-7SB00-0AX0 single operation

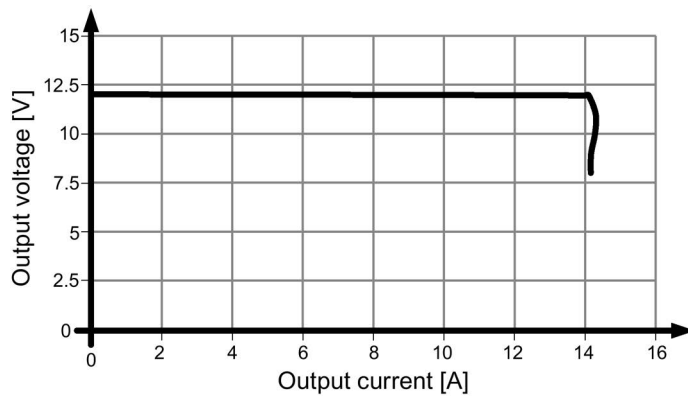

Figure 6-4 Output characteristic 6EP3324-7SB00-3AX0 single operation

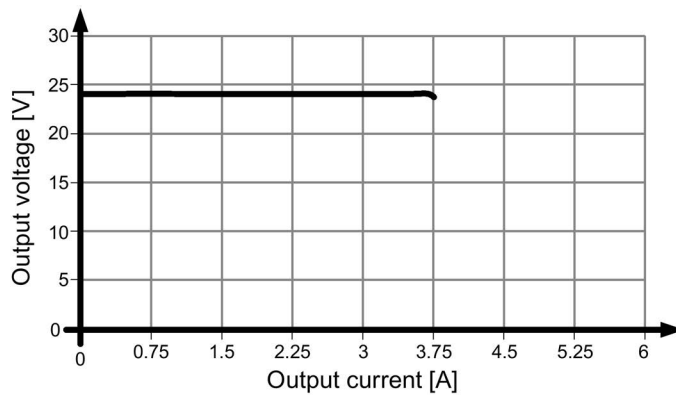

Figure 6-5 Output characteristic 6EP3333-7LB00-0AX0 single operation

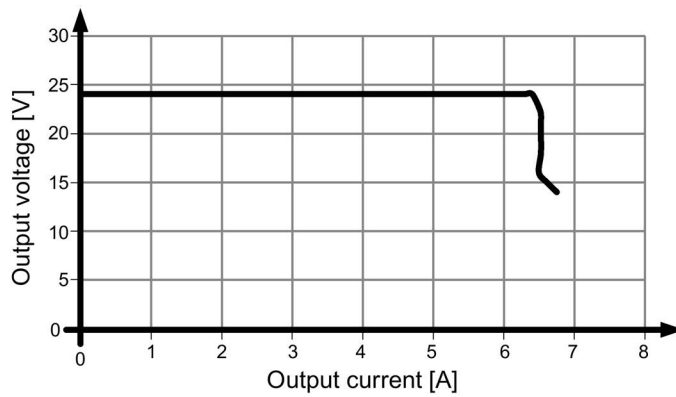

Figure 6-6 Output characteristic 6EP3333-7SB00-0AX0 single operation

6.2 Output

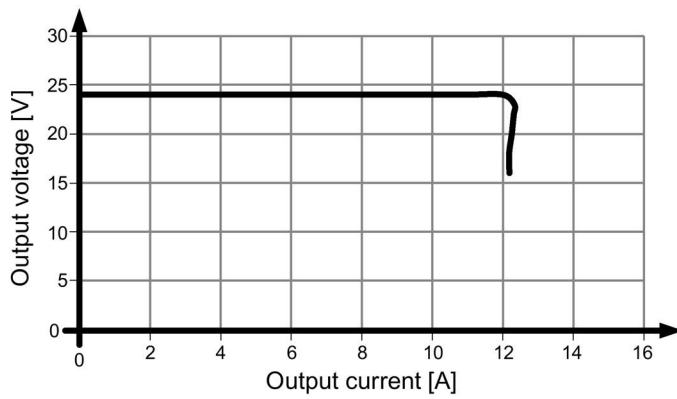

Figure 6-7 Output characteristic 6EP3334-7SB00-3AX0 single operation

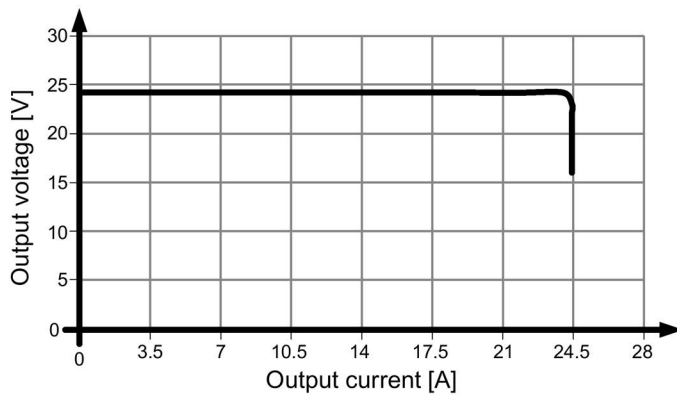

Figure 6-8 Output characteristic 6EP3336-7SB00-3AX0 single operation

The device supplies a constant output voltage until the current limit is reached. In the event of an overload, the output current and the output voltage are reduced.

When the output voltage falls below approx. 10 V, the 6EP1336-2BA10 device switches off, and automatically restarts. This response is repeated as long as the overload condition is present.

**Selector switch A on (parallel operation):**

The output voltage falls with increasing output current.

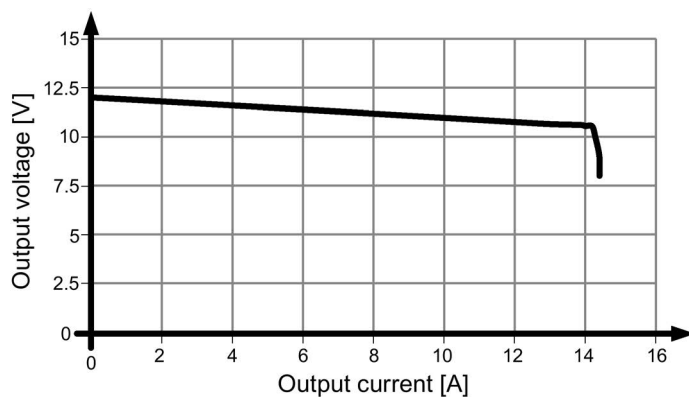

Figure 6-9 Output characteristic 6EP3324-7SB00-3AX0 parallel operation

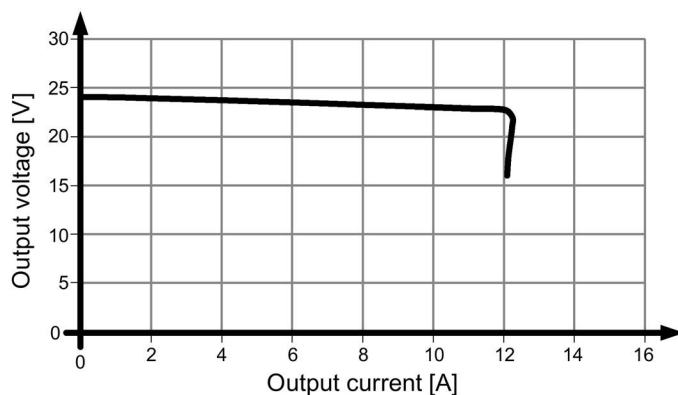

Figure 6-10 Output characteristic 6EP3334-7SB00-3AX0 parallel operation

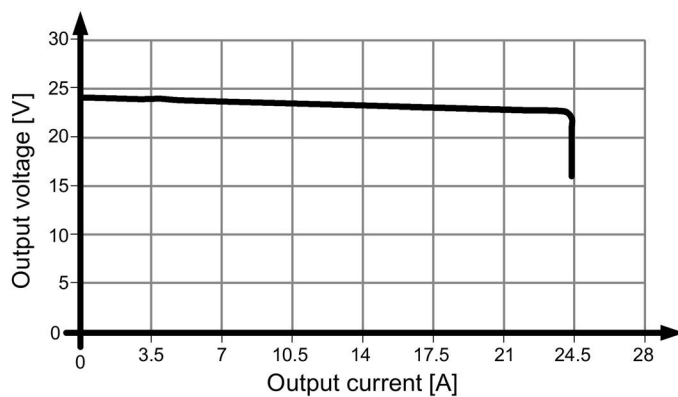

Figure 6-11 Output characteristic 6EP3336-7SB00-3AX0 parallel operation

### 6.3 Efficiency

	6EP3323-7SB00-0AX0 (12 V/7 A)	6EP3324-7SB00-3AX0 (12 V/12 A)
Efficiency at $U_{out\ rated}, I_{out\ rated}$ 120 V / 230 V AC approx.	86.2 % / 87.1 %	89.4 % / 89.9 %
Power loss at $U_{out\ rated}, I_{out\ rated}$ 120 V / 230 V AC approx.	14 W / 13 W	17 W / 17 W
Power loss when idling 120 V / 230 V AC approx.	1.2 W / 1.7 W	3.1 W / 2.6 W

	6EP3333-7LB00-0AX0 (24 V/3.7 A)	6EP3333-7SB00-0AX0 (24 V/5 A)	6EP3334-7SB00-3AX0 (24 V/10 A)	6EP3336-7SB00-3AX0 (24 V/20 A)
Efficiency at $U_{out\ rated}, I_{out\ rated}$ 120 V / 230 V AC approx.	88.0 % / 89.0 %	88.6 % / 90.2 %	92.2 % / 93.0 %	94.0 % / 95.5 %
Power loss at $U_{out\ rated}, I_{out\ rated}$ 120 V / 230 V AC approx.	12 W / 12 W	16 W / 14 W	21 W / 19 W	31 W / 23 W
Power loss when idling 120 V / 230 V AC approx.	1.5 W / 2.3 W	1.3 W / 2 W	2.6 W / 2.2 W	2.5 W / 2.5 W

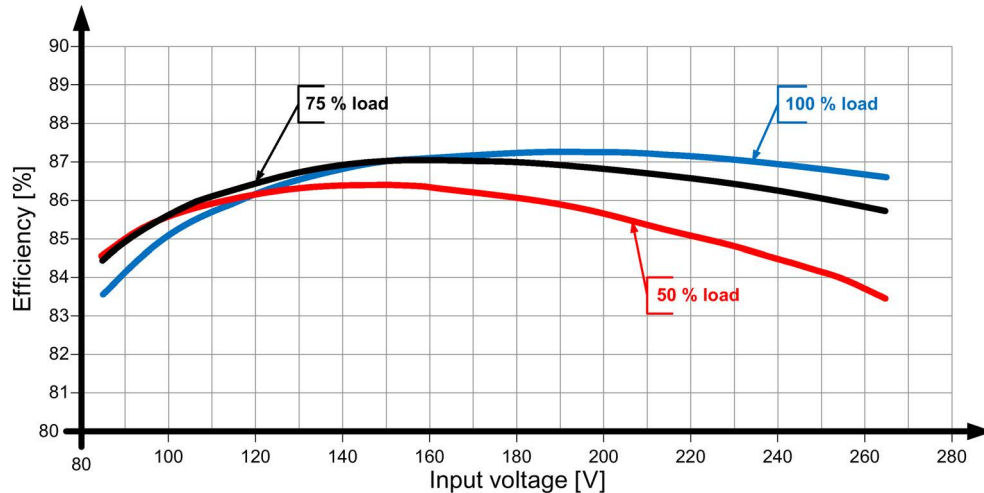

Figure 6-12 Efficiency 6EP3323-7SB00-0AX0

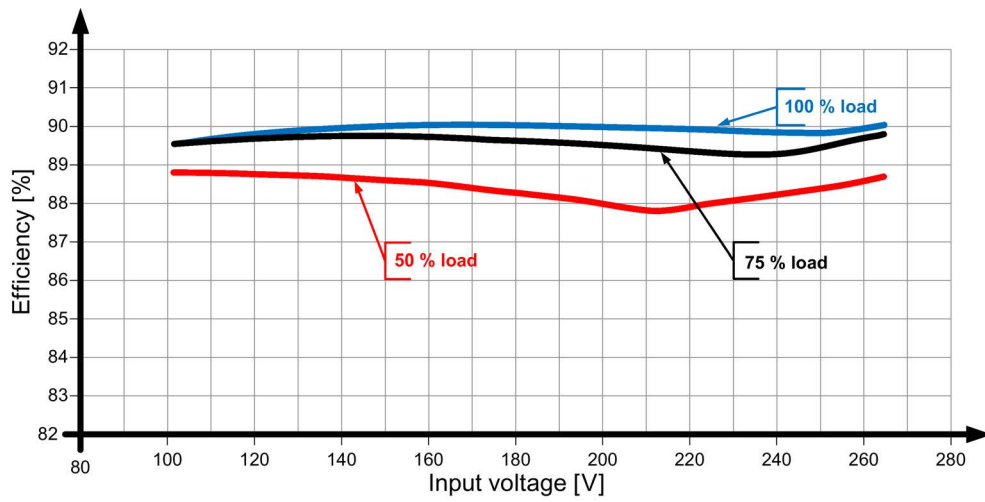

Figure 6-13 Efficiency 6EP3324-7SB00-3AX

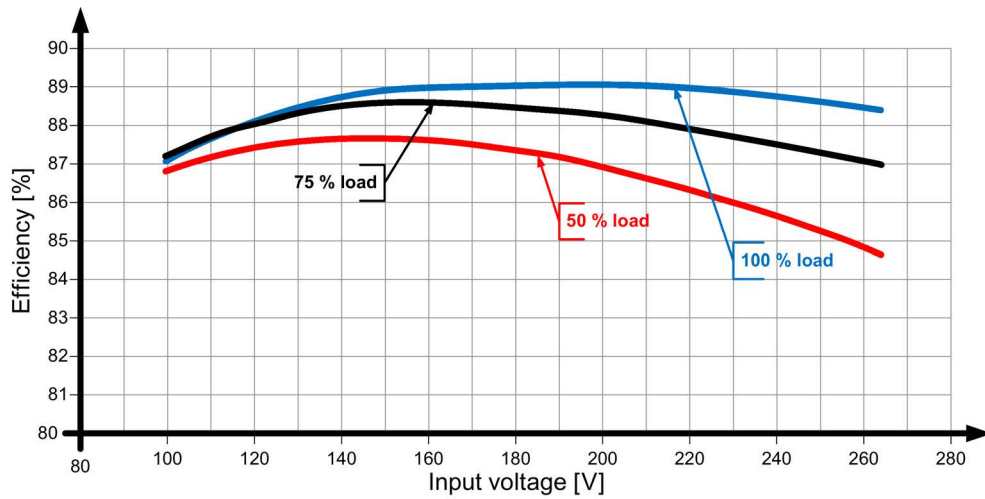

Figure 6-14 Efficiency 6EP3333-7LB00-0AX0

6.3 Efficiency

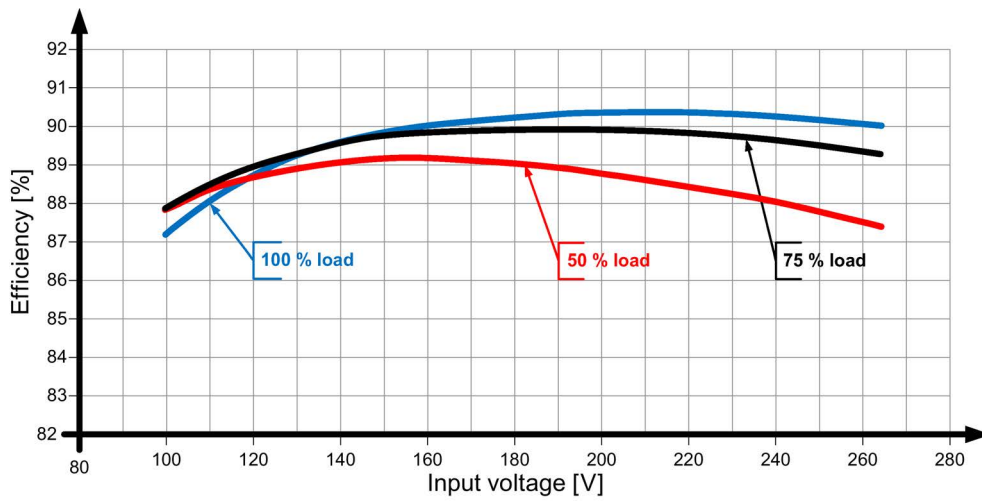

Figure 6-15 Efficiency 6EP3333-7SB00-0AX0

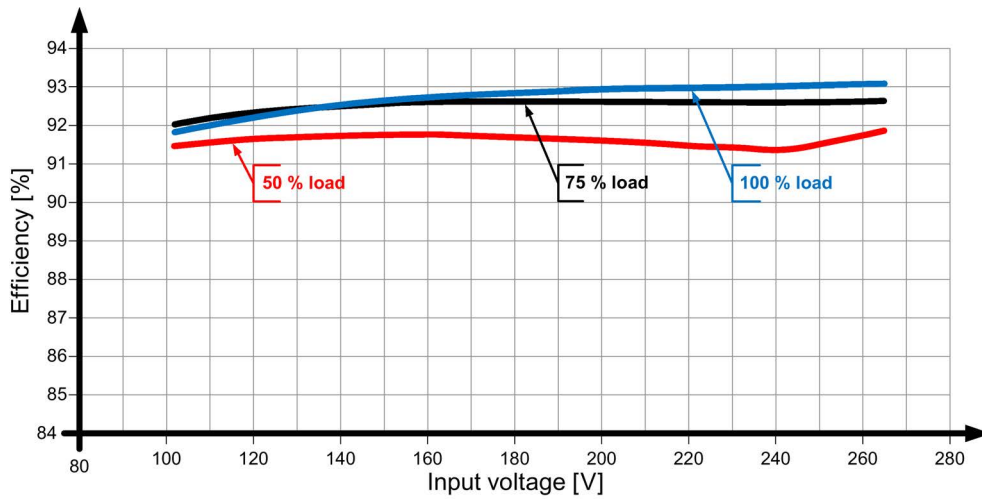

Figure 6-16 Efficiency 6EP3334-7SB00-3AX0

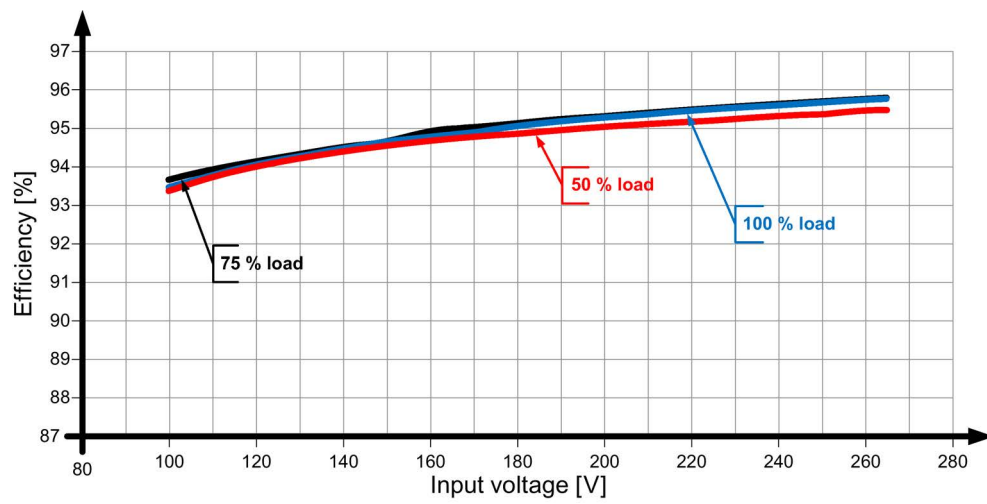

Figure 6-17 Efficiency 6EP3336-7SB00-3AX0

## 6.4 Closed-loop control

	6EP3323-7SB00-0AX0 (12 V/7 A) 6EP3333-7LB00-0AX0 (24 V/3.7 A) 6EP3333-7SB00-0AX0 (24 V/5 A)	6EP3324-7SB00-3AX0 (12 V/12 A) 6EP3334-7SB00-3AX0 (24 V/10 A)	6EP3336-7SB00-3AX0 (24 V/20 A)
Dyn. line regulation ( $U_{in \text{ rated}} \pm 15\%$ ), max.	0.3 % $U_{out}$	0.3 % $U_{out}$	0.3 % $U_{out}$
Dyn. load regulation ( $I_{out: 10/90/10\%}$ ), max.	$\pm 5\%$ $U_{out}$	$\pm 5\%$ $U_{out}$	$\pm 5\%$ $U_{out}$
Dyn. load regulation ( $I_{out: 10/90/10\%}$ ), typ.	$\pm 3\%$ $U_{out}$	$\pm 3\%$ $U_{out}$	$\pm 3\%$ $U_{out}$
Load-step settling time 10 to 90 %, max.	1 ms	1 ms	1 ms
Load-step settling time 10 to 90 %, typ.	0.5 ms	0.5 ms	0.5 ms
Load-step settling time 90 to 10 %, max.	1 ms	1 ms	1 ms
Load-step settling time 90 to 10 %, typ.	0.5 ms	0.5 ms	0.5 ms

## 6.5 Protection and monitoring

	6EP3323-7SB00-0AX0 (12 V/7 A)	6EP3324-7SB00-3AX0 (12 V/12 A)
Output overvoltage protection	in the case of an internal fault $U_{out} < 20\text{ V}$	in the case of an internal fault $U_{out} < 20\text{ V}$
Current limitation, typ.	9.3 A	14.7 A
• Remark	Overload capability with 150 % $I_{out\ rated}$ up to 5 s/min	Overload capability with 150 % $I_{out\ rated}$ up to 5 s/min
Short-circuit protection	Electronic trip, automatic restart (hiccup)	
Overload / short-circuit display	-	Diagnostics monitor, see Chapter Status displays and signaling (Page 12)

	6EP3333-7LB00-0AX0 (24 V/3.7 A)	6EP3333-7SB00-0AX0 (24 V/5 A)	6EP3334-7SB00-3AX0 (24 V/10 A)	6EP3336-7SB00-3AX0 (24 V/20 A)
Output overvoltage protection	in the case of an internal fault $U_{out} < 32\text{ V}$			
Current limitation, typ.	3.7 A	6.5 A	12.2 A	24.5 A
• Remark		Overload capability with 150 % $I_{out\ rated}$ up to 5 s/min	Overload capability with 150 % $I_{out\ rated}$ up to 5 s/min	Overload capability with 150 % $I_{out\ rated}$ up to 5 s/min
Short-circuit protection	electronic trip, automatic restart (hiccup)			
Overload / short-circuit display	-	-	Diagnostics monitor, see Chapter Status displays and signaling (Page 12)	

6.6 MTBF

## 6.6 MTBF

---

6EP3323-7SB00-0AX0 (12 V/7 A)  
6EP3324-7SB00-3AX0 (12 V/12 A)  
6EP3333-7LB00-0AX0 (24 V/3,7 A)  
6EP3333-7SB00-0AX0 (24 V/5 A)  
6EP3334-7SB00-3AX0 (24 V/10 A)  
6EP3336-7SB00-3AX0 (24 V/20 A)

---

Mean Time Between Failures      SN29500:> 500000 h at 40 °C, rated load, 24 h operation

---

## 6.7 Mechanical system

	6EP3323-7SB00-0AX0 (12 V/7 A) 6EP3333-7LB00-0AX0 (12 V/12 A) 6EP3333-7SB00-0AX0 (24 V/3.7 A)	6EP3324-7SB00-3AX0 (24 V/5 A) 6EP3334-7SB00-3AX0 (24 V/10 A)	6EP3336-7SB00-3AX0 (24 V/20 A)
Connection system	Spring-loaded terminal		
Connections: Line input	L, N, PE: 1 spring-loaded terminal for 4 mm <sup>2</sup> solid and 2.5 mm <sup>2</sup> finely stranded conductors		L, N, PE: 1 spring-loaded terminal for 4 mm <sup>2</sup> solid and 2.5 mm <sup>2</sup> finely stranded conductors
Connections: Output	+, -: 2 spring-loaded terminals each for 4 mm <sup>2</sup> solid and 2.5 mm <sup>2</sup> finely stranded conductors		+, -: 2 spring-loaded terminals each for 10 mm <sup>2</sup> solid and 6 mm <sup>2</sup> finely stranded conductors
Connections: Auxiliary contacts	Signaling contact: 2 spring-loaded terminals for 1.5 mm <sup>2</sup>		
Width of the housing	35 mm	45 mm	70 mm
Height of the housing	135 mm	135 mm	135 mm
Depth of the housing	125 mm	125 mm	155 mm
Installation width	35 mm	45 mm	70 mm
Mounting height	225 mm	225 mm	225 mm
Weight, approx.	0.7 kg	0.9 kg	1.5 kg
Product feature of the housing: housing that can be lined up next to one another	Yes		
Type of mounting: Wall/panel mounting	No		
Type of mounting: Rail mounting	Yes		
Type of mounting: S7-300 rail mounting	No		
Mounting	Can be snapped onto standard TH35-15/7,5 (EN 60715) mounting rails		

## 6.8 Dimension drawing

See chapter Dimensions and weight (Page 18)

CAD data that can be downloaded from the Internet:

6EP3323-7SB00-0AX0

[http://www.automation.siemens.com/bilddb/index.aspx?objKey=G\\_KT01\\_XX\\_01489](http://www.automation.siemens.com/bilddb/index.aspx?objKey=G_KT01_XX_01489)

6EP3324-7SB00-3AX0

[http://www.automation.siemens.com/bilddb/index.aspx?objKey=G\\_KT01\\_XX\\_01492](http://www.automation.siemens.com/bilddb/index.aspx?objKey=G_KT01_XX_01492)

6EP3333-7LB00-0AX0

[http://www.automation.siemens.com/bilddb/index.aspx?objKey=G\\_KT01\\_XX\\_01501](http://www.automation.siemens.com/bilddb/index.aspx?objKey=G_KT01_XX_01501)

6EP3333-7SB00-0AX0

[http://www.automation.siemens.com/bilddb/index.aspx?objKey=G\\_KT01\\_XX\\_01504](http://www.automation.siemens.com/bilddb/index.aspx?objKey=G_KT01_XX_01504)

6EP3334-7SB00-3AX0

[http://www.automation.siemens.com/bilddb/index.aspx?objKey=G\\_KT01\\_XX\\_01507](http://www.automation.siemens.com/bilddb/index.aspx?objKey=G_KT01_XX_01507)

6EP3336-7SB00-3AX0

[http://www.automation.siemens.com/bilddb/index.aspx?objKey=G\\_KT01\\_XX\\_01510](http://www.automation.siemens.com/bilddb/index.aspx?objKey=G_KT01_XX_01510)

## Safety, approvals, EMC

### 7.1 Safety

	6EP3323-7SB00-0AX0 (12 V/7 A) 6EP3324-7SB00-3AX0 (12 V/12 A) 6EP3333-7LB00-0AX0 (24 V/3.7 A) 6EP3333-7SB00-0AX0 (24 V/5 A) 6EP3334-7SB00-3AX0 (24 V/10 A) 6EP3336-7SB00-3AX0 (24 V/20 A)
Primary/secondary galvanic isolation	Yes
Galvanic isolation	SELV output voltage $U_{out}$ acc. to EN 60950-1 and EN 50178 Transformer according to EN 61558-2-16
Protection class	Class I
Degree of protection (EN 60529)	IP20
Leakage current, typ.	1 mA
Leakage current, max.	3.5 mA
Test voltage	See Table 7-1 Test voltage (Page 62)

## 7.2 Test voltage

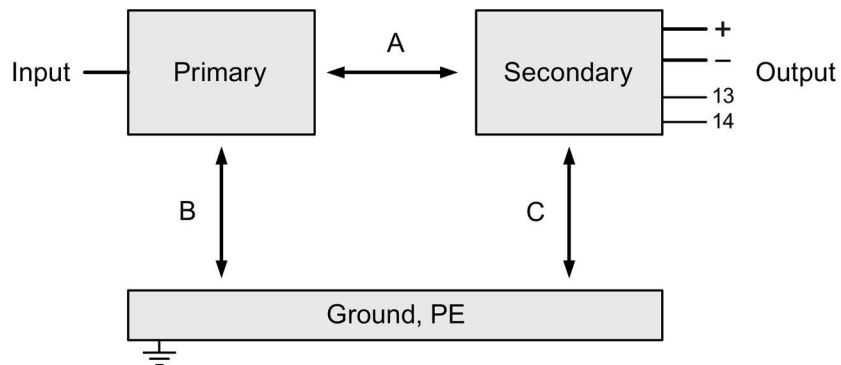

Figure 7-1 Test voltage diagram

Only the manufacturer can perform the type test and production test; users can also perform the field test.

Preconditions for performing the field test:

Tests (A) & (B)

- Connect the input terminals with one another (L1, N (L2))
- Connect the output terminals, signaling contact and PE with one another

Test (C)

- Connect the output terminals and signaling contact with one another and measure with respect to PE

Table 7- 1 Test voltage

	Test time	Prim ↔ sec (A)	Prim ↔ PE (B)	Sec ↔ PE (C)
Type test	60 s	4200 V DC	2200 V DC	850 V DC
Production test	1 s	4200 V DC	2200 V DC	850 V DC
Field test	1 s	4200 V DC	2200 V DC	850 V DC

Remark:

Tripping current for DC measurement: max. 10 mA

## 7.3 Approvals

	<b>6EP3323-7SB00-0AX0 (12 V/7 A)</b> <b>6EP3324-7SB00-3AX0 (12 V/12 A)</b> <b>6EP3333-7LB00-0AX0 (24 V/3.7 A)</b> <b>6EP3333-7SB00-0AX0 (24 V/5 A)</b> <b>6EP3334-7SB00-3AX0 (24 V/10 A)</b> <b>6EP3336-7SB00-3AX0 (24 V/20 A)</b>
CE marking	Yes, (2014/35/EU, 2014/30/EU and 2011/65/EU)
CSA approval	Yes, CSA C22.2 No. 60950-1, cCSAus (ANSI/ISA 12.12.01)
UL/cUL approval	cULus-listed (UL 508, CSA 22.2 No. 107.1), File E197259, for 6EP3333-7LB00-0AX0: NEC class2 (acc. to UL 60950-1/UL 1310), File E151273
CB approval	Yes
CB-Scheme	IEC 60950-1
SEMI F47	Yes
Marine approvals	Available soon

## 7.4 EMC

6EP3323-7SB00-0AX0 (12 V/7 A) 6EP3324-7SB00-3AX0 (12 V/12 A) 6EP3333-7LB00-0AX0 (24 V/3,7 A) 6EP3333-7SB00-0AX0 (24 V/5 A) 6EP3334-7SB00-3AX0 (24 V/10 A) 6EP3336-7SB00-3AX0 (24 V/20 A)		
Electrostatic discharge	EN 61000-4-2	8 kV contact, 8 kV air
Electromagnetic fields	EN 61000-4-3	80 ... 1000 MHz 10 V/m 1400 ... 2000 MHz 10 V/m 2000 ... 2700 MHz 10 V/m 895 ... 905 MHz and 1.89 GHz 10 V/m
High-speed transient disturbance variables (burst)	EN 61000-4-4	2 kV at line connections 1 kV at DC output
Surge voltages	EN 61000-4-5	2 kV symmetrical at the line connections 4 kV asymmetrical at the line connections 500 V symmetrical/asymmetrical on DC output cables
High-frequency fields	EN 61000-4-6	10 V; 0.15 ... 80 MHz
Magnetic fields	EN 61000-4-8	Not applicable
Voltage dips	EN 61000-4-11	100% for 20 ms, 60% for 200 ms, 30% for 500 ms
Voltage interruptions	EN 61000-4-11	100% for 5000 ms
Emitted interference	EN 55022	Class B
Line harmonics limitation	EN 61000-3-2	Class A
Generic standards	EN 61000-6-2	Immunity for industrial environments
	EN 61000-6-3	Emission for residential areas

## Ambient conditions

	6EP3323-7SB00-0AX0 (12 V/7 A) 6EP3324-7SB00-3AX0 (12 V/12 A) 6EP3333-7LB00-0AX0 (24 V/3.7 A) 6EP3333-7SB00-0AX0 (24 V/5 A) 6EP3334-7SB00-3AX0 (24 V/10 A) 6EP3336-7SB00-3AX0 (24 V/20 A)
Ambient temperature	-25 ... 70 °C for natural convection (self convection) Tested according to: <ul style="list-style-type: none"> <li>• EN 60068-2-1 cold</li> <li>• EN 60068-2-2 dry heat</li> <li>• EN 60068-2-78 humid heat, constant</li> <li>• EN 60068-2-14 temperature change</li> </ul>
Transport and storage temperature	-40 ... 85 °C Tests (packed for shipping) according to: <ul style="list-style-type: none"> <li>• EN 60068-2-1 cold</li> <li>• EN 60068-2-2 dry heat</li> <li>• EN 60068-2-30 humid heat, cyclic</li> </ul>
Humidity class	Climatic class 3K3 according to EN 60721, without condensation
Mechanical stressing in operation	Tested according to: <ul style="list-style-type: none"> <li>• EN 60068-2-6 vibration, test Fc: 3.5 mm deflection in the range 5 – 8.4 Hz 2 g acceleration in the range 8.4 – 150 Hz</li> <li>• EN 60068-2-27 shock, test Ea: acceleration 150 m/s<sup>2</sup>, test duration 11 ms</li> </ul>

---

6EP3323-7SB00-0AX0 (12 V/7 A)  
6EP3324-7SB00-3AX0 (12 V/12 A)  
6EP3333-7LB00-0AX0 (24 V/3.7 A)  
6EP3333-7SB00-0AX0 (24 V/5 A)  
6EP3334-7SB00-3AX0 (24 V/10 A)  
6EP3336-7SB00-3AX0 (24 V/20 A)

---

Damaging gases

Tested according to:

- EN 60068-2-42 sulfur dioxide
  - EN 60068-2-43 hydrogen sulfide
- 

Atmospheric pressure

Operation:

- 1080 - 795 hPa (0 - 2000 m)
- For operation at altitudes of 2000 m up to 6000 m above sea level:  
output must be derated by -7.5% / 1000 m or  
the ambient temperature must be reduced by 5 K / 1000 m  
see Figure 4-7 Mounting height derating (Page 25)
- Overvoltage category:  
III to 2000 m (EN 50178)  
II from 2000 m to 6000 m (EN 50178)  
II to 2000 m (EN 60950-1)  
I from 2000 m to 6000 m (EN 60950-1)

Storage:

- 1080 - 660 hPa (0 - 3500 m)
-

# Applications

## 9.1 Parallel connection to increase the power rating

To increase the power rating, power supplies of the same type can be directly connected in parallel.

The following must be observed:

- The cables connected to each power supply at terminals "+" and "-" must have identical lengths and the same cable cross-sections (or the same impedance) up to a common external connection point (terminal strip) if possible.
- The power supplies connected in parallel must be switched on simultaneously with a common switch in the line feeder cable (e.g. with the main switch available in control cabinets).
- The output voltages measured in no-load operation for the power supplies that are not yet connected in parallel should not deviate more than a maximum of 50 mV. This usually corresponds to the factory setting. If the output voltage is changed, you should connect the "-" terminals and then, in no-load operation, measure the voltage difference between the "+" terminals that have not yet been connected. The voltage difference should not exceed 50 mV.

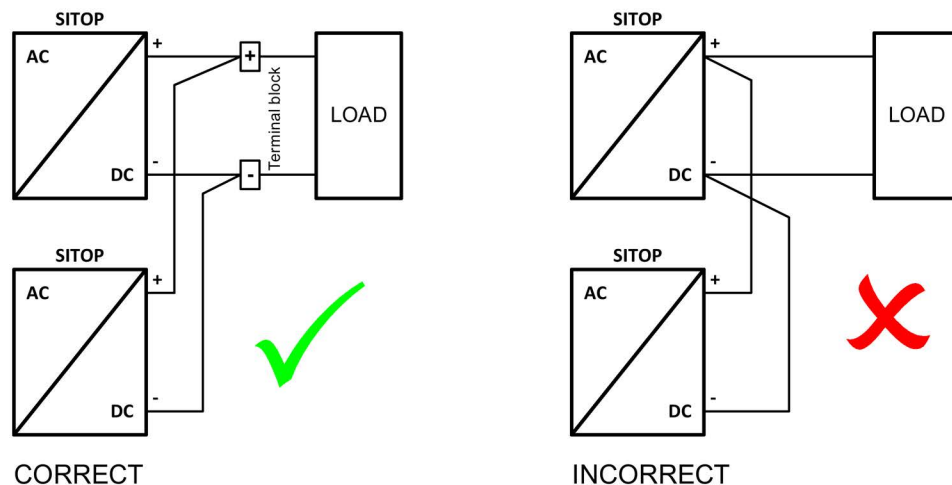

Figure 9-1 Parallel connection

### Note

It is not permissible to take into account simultaneous overload capability (Extra-Power 150% for 5 s/min) of several power supplies connected in parallel when configuring the power supply system.

**NOTICE**

**Protective circuit for the parallel connection of more than two power supplies**

When connecting more than two power supplies in parallel, additional measures must be taken to prevent high reverse currents in the event of a secondary device fault. For this purpose, a suitable protective circuit (e.g. decoupling diode or DC-capable circuit breaker) must be installed between each "+" terminal of the power supply and the common connection point.

## 9.2 Overload protection in the 24 V output circuit

If an overload occurs, the electronic current limiting function of the 24 V power supply limits the output current to a maximum value (see Section Technical data (Page 43)). The output cables are protected against a thermal overload if they are dimensioned corresponding to the maximum rms output current, or protected using additional components (for example, miniature circuit breaker, fuses).

However, a load circuit that fails as a result of overload, for instance, should frequently be reliably and quickly identified and specifically switched off before the power supply goes into current-limiting mode (in current-limiting mode, the supply voltage would also be reduced for all of the remaining 24 V loads).

The SITOP PSE200U selectivity module with 4 outputs (versions with adjustable output current range for each output from 0.5 - 3 A and 3 - 10 A) is available for this purpose; this monitors the 24 V branches for overload and short circuit (Figure 9-3 Electronic protection of 24 V loads using the SITOP PSE200U selectivity module (Page 69)). Brief current peaks, e.g. as a result of a high inrush current, are permitted, and branches with a longer overload are switched into a no-current condition. This is also ensured for cables in a high-ohmic condition and for short circuits that slowly develop over time.

When an output fails, the fault is signaled using a group signal contact or as a single channel signal, and the branch of the module involved is displayed using an LED.

For variants with single-channel signaling, function blocks for evaluation purposes are available for SIMATIC S7-1200/1500/300/400, for STEP 7 Classic and TIA Portal at no charge.

You can find additional information at:

Manual SITOP selectivity modules

(<https://support.industry.siemens.com/cs/ww/en/view/108989004>)

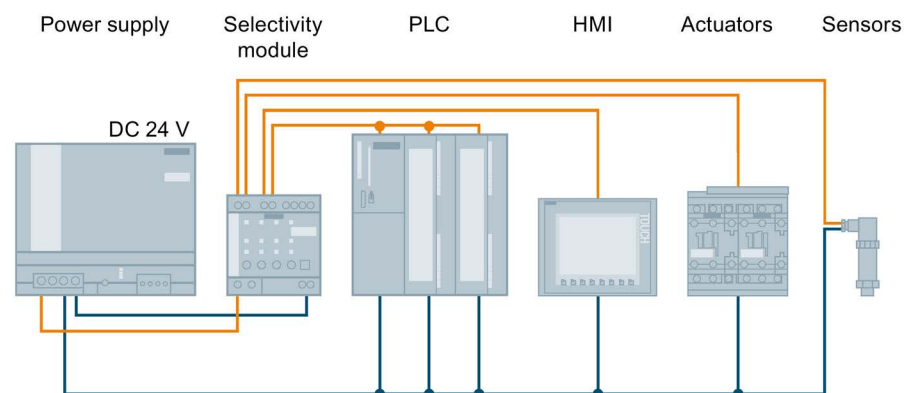

Figure 9-2 Electronic protection of 24 V loads using the SITOP PSE200U selectivity module

## 9.3 Protection against short-time voltage dips

For a drop in the line-side supply voltage, the 24 V power supply still maintains the output voltage for a short time in the millisecond range (see Chapter Technical data (Page 43)).

For line supplies that manifest frequent brief voltage dips, in order to increase the power supply reliability, it may make sense to increase the line buffering time in the device using an additional SITOP PSE201U buffer module.

The SITOP PSE201U buffer module, based on electrolytic capacitors, is connected in parallel to the power supply output (Figure 9-4 Buffering brief power failures using the SITOP PSE201U buffer module (Page 70)). The buffer time is 200 ms at 40 A up to 1.6 s for a load current of 5 A. This time can be increased a multiple number of times by connecting buffer modules in parallel; the maximum buffer time is 10 s.

You can find additional information at:

SITOP PSE201U manual (<https://support.industry.siemens.com/cs/ww/en/view/41129219>)

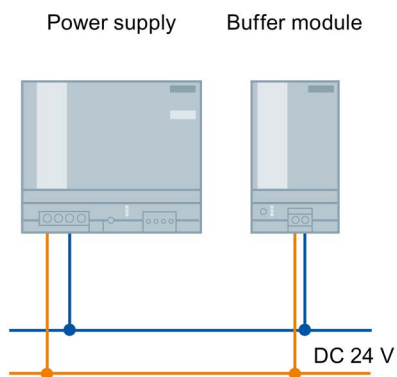

Figure 9-3 Buffering brief power failures using the SITOP PSE201U buffer module

## 9.4 Protecting against longer power failures

Sudden and longer failures of the line supply voltage can result in undefined states and significant danger as a result of the associated failure of the plant or system control. The SITOP power supply product portfolio includes various DC-UPS solutions to prevent the failure of the 24 V power supply voltage.

Power supply failures up into the minutes range can be buffered using the maintenance-free SITOP UPS500 DC-UPS modules based on capacitors (Figure 9-5 24 V buffering to allow the saving of process data and controlled shutdown of PCs (Page 71)).

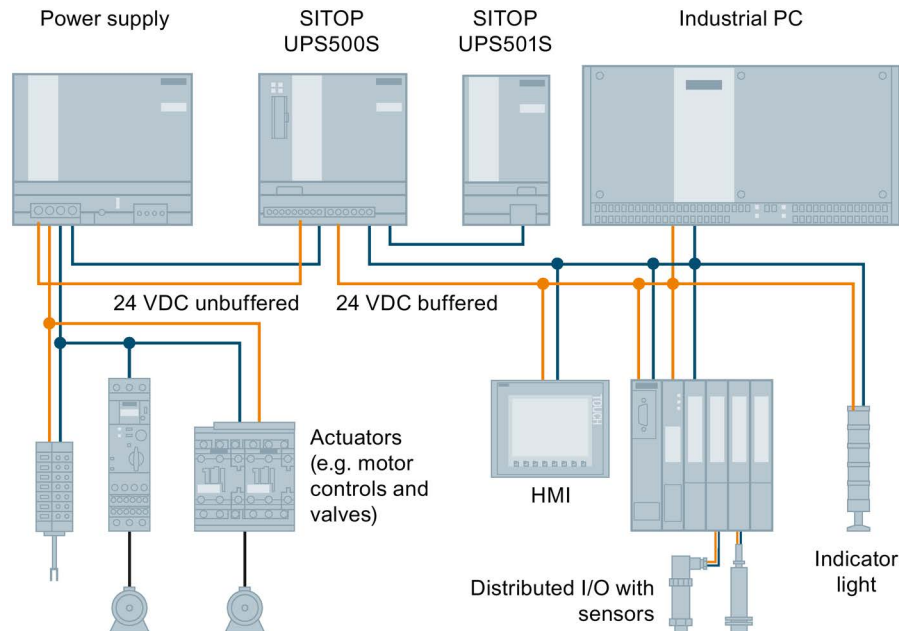

Figure 9-4 24 V buffering to allow the saving of process data and controlled shutdown of PCs

Using the free-of-charge SITOP DC-UPS software tool, DC-UPS systems can be simply integrated into PC-based automation solutions. This supports further processing of the status signals and safely running down the PC.

You can find additional information at:

Manual, DC UPS with capacitors

(<https://support.industry.siemens.com/cs/ww/en/ps/18042/man>)

Using DC UPS SITOP UPS1600 and SITOP UPS1100 battery modules, buffer times in the range of hours can be implemented. Intelligent battery management using Energy Storage Link automatically detects the UPS1100 energy storage device, and ensures optimum temperature-controlled charging and continuous monitoring. The UPS1600 can be flexibly integrated into the widest range of automation applications with its digital inputs/outputs as well as optional USB interface or Ethernet/PROFINET port.

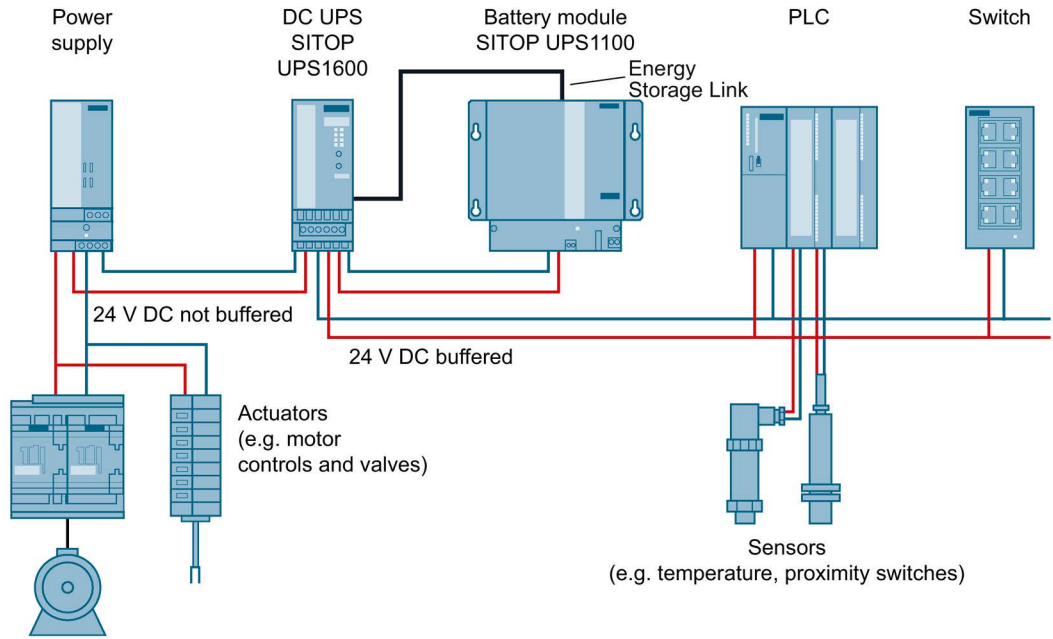

Figure 9-5 24 V buffering with SITOP UPS1600 to maintain communication, signaling functions, sensor measured values and position values

For open, PC-based automation systems, configuration and monitoring is realized using the SITOP UPS Manager PC software, which is available at no charge. This allows PC responses to the operating states of the DC UPS to be freely selected – and offers comprehensive diagnostic functions.

For TIA-based automation systems, the UPS1600 is engineered using the TIA Portal. Special function blocks for SIMATIC S7-300/400/1200 and S7-1500 – available at no charge – make it easy to integrate operating and diagnostics information into STEP 7 user programs. Preconfigured UPS faceplates for WinCC visualization can be downloaded at no charge.

You can find additional information at:

DC UPS SITOP UPS1600/UPS1100 Manual  
<https://support.industry.siemens.com/cs/ww/en/view/84977415>

# Environment

# 10

The devices are in conformance with RoHS.

As a rule, only non-silicon precipitating materials are used.

## Disposal guidelines



Packaging and packaging aids can and should always be recycled. The product itself may not be disposed of as domestic refuse.



## Technical support

Technical support for all IA/DT products can be accessed through the following communication channels:

- Telephone: + 49 (0) 911 895 7222
- Internet:  
Web form for support request (<http://www.siemens.de/automation/support-request>)

## Technical documentation on the Internet

Operating instructions and manuals for SITOP are available in the Internet:  
Operating instructions/manuals (<http://www.siemens.com/sitop/manuals>)

## SITOP power supply homepage

General news about our power supplies is available in the Internet at the SITOP home page:  
SITOP (<http://www.siemens.com/sitop>)

## Information material

SITOP information can be downloaded from the Internet:  
Information and download center (<http://www.siemens.com/sitop-infomaterial>)

## CAX data

2D/3D data and circuit diagram macros can be downloaded from the Internet:  
Siemens image database (<http://www.siemens.com/sitop-cax>)

Request all CAX data via the CAX download manager:  
CAX shopping cart (<http://www.siemens.com/cax>)

## SITOP Selection Tool

Simply and quickly select the optimum the power supply or DC-UPS:  
SITOP Selection Tool (<http://www.siemens.com/sitop-selection-tool>)

## Online catalog and ordering system

The online catalog and the online ordering system are available through the Industry Mall homepage:  
Industry Mall (<http://www.siemens.com/industrymall/de>)

### **Contact persons**

If you have any questions regarding the use of our products, then contact the Siemens contact person in your regional Siemens sales office.

You can find these addresses as follows:

- On the Internet (<http://www.automation.siemens.com/partner>)
- Industry Mall (<http://www.siemens.com/industrymall/de>)