

# Terminal Blocks

## 2013 Product Catalog Terminal Block Supplement

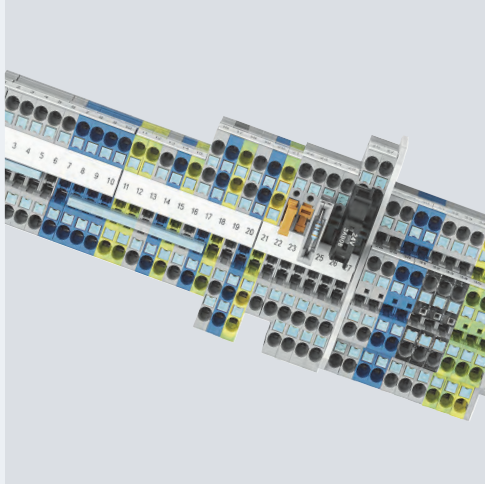

Refer to the Industry Mall for current updates of this catalog:  
[www.siemens.com/industrymall](http://www.siemens.com/industrymall)

Please contact your local Siemens branch.

Customer Support  
Phone: 866-663-7324

Application Support  
Phone: 877-234-1122

Product Technical Support  
Phone: 1-800-333-7421

	Introduction	1
8WH8	8WH6 iPo Plug-In Terminals	2
	8WH6 iPo Installation Terminals	3
	8WH2 Spring-Loaded Terminals	4
	8WH5 Combination Plug-In Terminals	5
	8WH3 Insulation Displacement Terminals	6
	8WH1 Screw Terminals	7
	Accessories for 8WH Terminal Blocks	8
8WA	8WA1 Screw Terminals	9
	Accessories for 8WA Terminal Blocks	10
	Appendix	11

# Get all the information you need – with just one click



Information	Planning/Orders	Operation/Service	Training
<ul style="list-style-type: none"><li>– Internet</li><li>– Information and Download Center</li><li>– Newsletter</li><li>– Picture Database</li></ul>	<ul style="list-style-type: none"><li>– Industry Mall</li><li>– Configurations</li></ul>	<ul style="list-style-type: none"><li>– Technical Support</li><li>– Service &amp; Support Portal</li><li>– CAx Online Generator</li><li>– My Documentation Manager</li><li>– Support Request</li></ul>	<ul style="list-style-type: none"><li>– SITRAIN Portal</li></ul>

[www.siemens.com/lowvoltage/support](http://www.siemens.com/lowvoltage/support)

**Always at your service – every step of the way**

We offer comprehensive support, from planning to configuration to operation.

# Introduction

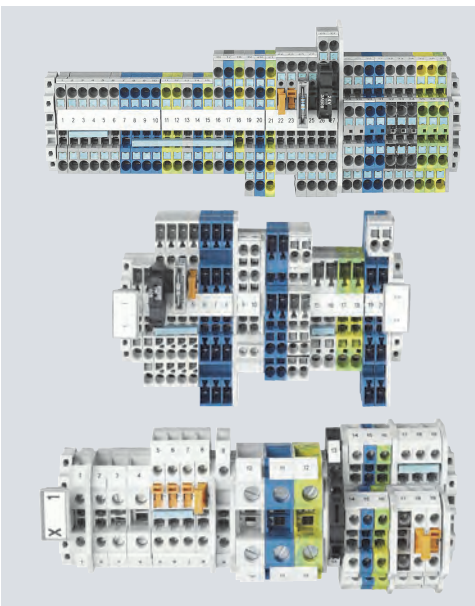

## 8WH and 8WA Terminal Blocks

- 1/2 General data
- 1/3 Support rails/protective conductor busbars

## 8WH Terminal Blocks

- 1/4 8WH order selection

### More technical product information:

Service&Support Portal:  
[www.support.automation.siemens.com](http://www.support.automation.siemens.com)

Product List:  
Technical specifications







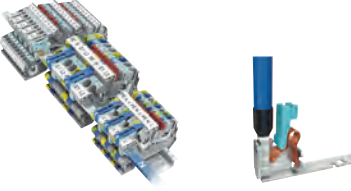

Entry List:  
Updates / Downloads / FAQ /  
Manuals / Operating instructions /  
Characteristic curves / Certificates

# Introduction

## 8WH and 8WA Terminal Blocks

### General data

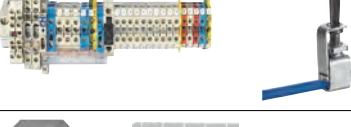
#### Overview

		Connection system	Section	Special features
<b>8WH terminals</b>				
		8WH6 iPo plug-in terminals (iPo: in-Push-out)	2	The iPo connection method combines the advantages of spring-loaded and plug-in terminals - both rigid and flexible wires are easy to insert without the need for tools. Fast installation - with a minimum of effort and maximum contact stability.
		8WH6 iPo installation terminals	3	The iPo connection method combines the advantages of spring-loaded and plug-in terminals - both rigid and flexible wires are easy to insert without the need for tools. Fast installation - with a minimum of effort and maximum contact stability. Fast removal by simply pressing the unlatching button.
		8WH2 spring-loaded terminals	4	With the spring-loaded connection method, the tension spring exerts constant pressure on the conductor, which ensures excellent contact stability - even with applications subject to high levels of vibration. Fast removal by simply pressing the unlatching button.
		8WH5 combination plug-in terminals	5	Combination plug-in terminals are used where high availability is essential in the event of a fault. The contact system is able to withstand even extreme levels of vibration and both the terminal and the connector are fingerproof.
		8WH3 insulation displacement terminals	6	Thanks to the use of insulation displacement terminals, there is no need to strip the conductor. This ensures secure contact between the conductor and the connecting wire of the terminal.
		8WH1 screw terminals	7	The screw terminals have an impressively compact design and offer optimum handling. The elastic deformation capability of the terminal body prevents any creepage of the clamped conductor. Suitable for applications up to 1000 V DC.
		Accessories for 8WH	8	The 8WH accessories supplement the 8WH product range with the additional components required for installation.
<b>8WA terminals</b>				
		8WA1 screw terminals	9	The tried and tested screw terminals are insulated on both sides and enclosed at both ends. These terminals are extremely robust and can withstand high mechanical and thermal loads.
		Accessories for 8WA	10	The 8WA terminal block accessories supplement the 8WA product range with the additional components required for installation.

#### Rated short-time withstand current

Our terminals are able to withstand a rated short-time current corresponding to a current density of  $120 \text{ A/mm}^2$  specific to the nominal cross-section for one second.

### Overview

Support rail type							Excerpt from IEC 60947-7-2/EN 60947-7-2/VDE 0611 Part 3		
Width	Height	Thick-ness	Perforation type	Material	Surface	Rail profile	Short-circuit strength (Cu conductor)	Short-time withstand current, 1 s	Max. permissible thermal rated current with PEN function
mm	mm	mm					mm <sup>2</sup> <sup>1)</sup>	kA	A
35	7.5	1.5	Non-perforated	Steel	Chromated	Standard mounting rail, acc. to EN 60 715 – 35 × 7.5	16	1.92	<sup>1)</sup>
35	7.5	1.5	With holes	Steel	Chromated	Standard mounting rail, acc. to EN 60 715 – 35 × 7.5	16	1.92	<sup>2)</sup>
35	7.5	1.5	Non-perforated	Steel	Galvanized	Standard mounting rail, dimensions acc. to EN 60 715 – 35 × 7.5	16	1.92	<sup>2)</sup>
35	7.5	1.5	With holes	Steel	Galvanized	Standard mounting rail, dimensions acc. to EN 60 715 – 35 × 7.5	16	1.92	<sup>2)</sup>
35	7.5	1.5	Non-perforated	V2A high-grade steel	Chromated	Standard mounting rail, dimensions acc. to EN 60 715 – 35 × 7.5	16	1.92	<sup>2)</sup>
35	7.5	1.5	Non-perforated	Copper	Chromated	Standard mounting rail, dimensions acc. to EN 60 715 – 35 × 7.5	50	6.0	150
35	7.5	1.5	Non-perforated	Aluminum	Chromated	Standard mounting rail, dimensions acc. to EN 60 715 – 35 × 7.5	35	4.2	125
35	15	2.3	Non-perforated	Steel	Chromated	Standard mounting rail, acc. to EN 60 715 – 35 × 15	50	6.0	<sup>2)</sup>
35	15	1.5	Non-perforated	Steel	Chromated	Standard mounting rail, similar to EN 60 715 – 35 × 15	35	4.2	<sup>2)</sup>
35	15	1.5	With holes	Steel	Chromated	Standard mounting rail, similar to EN 60 715 – 35 × 15	35	4.2	<sup>2)</sup>
35	15	1.5	Non-perforated	Steel	Galvanized	Standard mounting rail, similar to EN 60 715 – 35 × 15	35	4.2	<sup>2)</sup>
35	15	1.5	With holes	Steel	Galvanized	Standard mounting rail, similar to EN 60 715 – 35 × 15	35	4.2	<sup>2)</sup>
35	15	1.5	Non-perforated	Copper	Chromated	Standard mounting rail, similar to EN 60 715 – 35 × 15	95	11.4	232
35	15	1.5	Non-perforated	Aluminum	Chromated	Standard mounting rail, similar to EN 60 715 – 35 × 15	70	8.4	192

<sup>1)</sup> Cross-sections calculated acc. to IEC 60439-1 / EN 60 439-1 / EN 60439-1 / VDE 0660 Part 500.

<sup>2)</sup> Steel protective conductor busbars are not permissible for PEN function.

# Introduction

## 8WH Terminal Blocks

### 8WH order selection

Terminal type	Connection type	Design	Number of terminals	Version	MLFB digits		
					1...9	8...12	
Installation terminals	iPo	Standard	2	L	8WH6	001-	
			4	L/L	8WH6	001-	
			4	L/N	8WH6	001-	
			5	PE/L/L	8WH6	001-	
			5	PE/L/N	8WH6	001-	
			5	PE/L/NT	8WH6	001-	
			5	PE/L/N isolating blade	8WH6	001-	
			5	PE/L/L isolating blade	8WH6	001-	
			5	PE/L/L through-type term. for isolat. term.	8WH6	001-	
			5	PE/L/L isolation	8WH6	001-	
	Spring-loaded terminals		Two-tier	4	L/PE	8WH2	020-
				4	N/PE	8WH2	020-
				4	N/L	8WH2	020-
			Three-tier	6	PE/L/N	8WH2	030-
				6	PE/L/L	8WH2	030-

Order No., e.g.

8WH6 001-

4FF00

**Insta terminal:** Plug-in design · 5 connection points  
2.5 mm<sup>2</sup> · Range of functions

8WH order selection

	1.5 mm <sup>2</sup>			2.5 mm <sup>2</sup>				4 mm <sup>2</sup>		
	Through-type terminal, gray	Through-type terminal, blue	PE terminal, green/yellow	Through-type terminal, gray	Through-type terminal, blue	PE terminal	Terminals with range of functions	Through-type terminal, gray	Through-type terminal, blue	PE terminal, green/yellow
							4QF00			
							4DF00			
							4CF00			
							4HF00			
							4EF00			
							4FF00			
							4GF00			
							4NF00			
							4PF00			
							4MF00			
							4AF00			
							4BF00			
							4CF00			
							4EF00			
							4HF00			

# Introduction

## 8WH Terminal Blocks

### 8WH order selection

Connection type	Terminals	Design	Number of terminals MLFB digits 1...7 MLFB digits 8...12	1.5 mm <sup>2</sup>				2.5 mm <sup>2</sup>								
				Through-type terminal, gray	Through-type terminal, colored	Through-type terminal, blue	PE terminal, green/yellow	Through-type terminal, gray	Through-type terminal, colored	Through-type terminal, blue	Instrument isolating terminal, blue	Isolating terminal, gray	Instrument isolating terminal, gray	PE terminal green/yellow		
Screw terminal	Standard		2	8WH1 000-					0AF00		0AF01					OCF07
		Two-tier	4	8WH1 020-					0AF00		0AF01					OCF07
		Two-tier	4	8WH1 025-					0AF00							
Spring-loaded terminal	Standard		2	8WH2 000-	0AE00	0AE0 <sup>1)</sup>	0AE01	0CE07	0AF00	0AF0 <sup>1)</sup>	0AF01		6AF00	6CF00	OCF07	
			3	8WH2 003-	0AE00		0AE01	0CE07	0AF00		0AF01		6AF00	6CF00	OCF07	
			4	8WH2 004-	0AE00		0AE01	0CE07	0AF00		0AF01	6CF01	6AF00	6CF00	OCF07	
		Two-tier	4	8WH2 020-	0AE00		0AE01	0CE07	0AF00		0AF01				OCF07	
			6	8WH2 023-					0AF00		0AF01				OCF07	
		Two-tier 1-pole	6	8WH2 022-					0AF00							
			4	8WH2 025-	0AE00				0AF00		0AF01					
		Three-tier	6	8WH2 030-					0AF00		0AF01					
		Three-tier	6	8WH2 035-					0AF00						OCF07	
	Four-tier	8	8WH2 040-					4LF00								
	Molded-case		2	8WH2 500-					0AF00		0AF01		6AF00	6CF00	OCF07	
			3	8WH2 503-					0AF00		0AF01				OCF07	
			4	8WH2 504-					0AF00		0AF01				OCF07	
Two-tier		4	8WH2 520-					0AF00		0AF01				OCF07		
iPo	Standard		2	8WH6 000-					0AF00		0AF01				OCF07	
			3	8WH6 003-					0AF00		0AF01				OCF07	
			4	8WH6 004-					0AF00		0AF01				OCF07	
		Two-tier	4	8WH6 020-					0AF00		0AF01				OCF07	
Combination plugs	Standard		2	8WH5 000-					0AF00		0AF01				OCF07	
			4	8WH5 004-					0AF00		0AF01				OCF07	
Insulation displacement terminal technology (IDC)	Standard		2	8WH3 000-	0AE00		0AE01	0CE07	0AF00		0AF01				OCF07	
			3	8WH3 003-	0AE00		0AE01	0CE07	0AF00		0AF01				OCF07	
			4	8WH3 004-	0AE00		0AE01	0CE07								
		Two-tier	4	8WH3 020-	0AE00		0AE01	0CE07								

Order No., e.g.

8WH2 500-

0AF00

**Standard terminal:** Spring-loaded terminal · compact · 2 connection points · 2.5 mm<sup>2</sup> · Through-type terminal, gray

# Introduction 8WH Terminal Blocks

## 8WH order selection

	4 mm <sup>2</sup>						6 mm <sup>2</sup>				10 mm <sup>2</sup>			16 mm <sup>2</sup>			35 mm <sup>2</sup>		
	Through-type terminal, gray	Through-type terminal, colored	Through-type terminal, blue	Isolating terminal, Gray	Instrument isolating terminal, gray	PE terminal, green/yellow	Through-type terminal, gray	Through-type terminal, blue	Isolating terminal, blue	PE terminal, green/yellow	Through-type terminal, gray	Through-type terminal, blue	PE terminal, green/yellow	Through-type terminal, gray	Through-type terminal, blue	PE terminal, green/yellow	Through-type terminal, gray	Through-type terminal, blue	PE terminal, green/yellow
	0AG00		0AG01	6AG00	6CG00	0CG07	0AH00	0AH01	6AH00	0CH07	0AJ00	0AJ01	0CJ07	0AK00	0AK01	0CK07	0AM00	0AM01	0CM07
	0AG00		0AG01	6AG00	6AC00	0CG07													
	0AG00																		
	0AG00	0AG0 <sup>1)</sup>	0AG01	6AG00	6CG00	0CG07	0AH00	0AH01		0CH07	0AJ00	0AJ01	0CJ07	0AK00	0AK01	0CK07	0AM00	0AM01	0CM07
	0AG00		0AG01			0CG07	0AH00	0AH01		0CH07									
	0AG00		0AG01			0CG07	0AH00	0AH01		0CH07									
	0AG00		0AG01			0CG07													
	0AG00																		
	0AG00																		
	4GL00																		
	0AG00		0AG01			0CG07	0AH00	0AH01		0CH07									
	0AG00		0AG01			0CG07	0AH00	0AH01		0CH07									
	0AG00		0AG01			0CG07													
	0AG00		0AG01			0CG07													
	0AG00		0AG01			0CG07													
	0AG00		0AG01			0CG07													

Red	Green <sup>1)</sup>	Orange	White	Yellow	Black
0AE02	0AE03	0AE04	0AE05	0AE06	0AE08

# Introduction

## 8WH Terminal Blocks

Notes

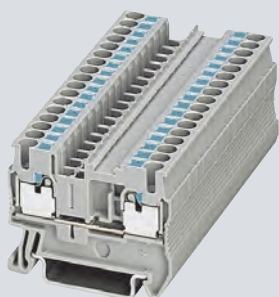

2/2	<b>Introduction</b>
2/3	<b>General data</b>
2/4	<b>8WH6 through-type terminals</b>
2/8	<b>8WH6 fuse terminals</b>
2/9	<b>8WH6 isolating blade terminals</b>
2/11	<b>8WH6 isolating terminals</b>
2/13	<b>8WH6 two-tier terminals</b>



## More technical product information:

Service&Support Portal:  
[www.support.automation.siemens.com](http://www.support.automation.siemens.com)

Product List:  
Technical specifications

Entry List:  
Updates / Downloads / FAQ /  
Manuals / Operating instructions /  
Characteristic curves / Certificates

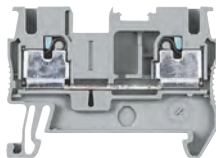
#### Overview

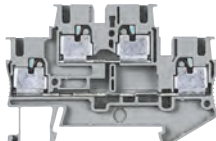
	Devices	Page	Function
	Through-type terminals	2/4	Connection of incoming and outgoing conductors
	Fuse terminals	2/8	Terminals which can be used to protect control circuits, for example
	Isolating blade terminals	2/9	Isolation of the circuit, e.g. for test purposes
	Isolating terminals	2/11	Isolation of the circuit, e.g. for test purposes
	Two-tier terminals	2/13	Compact form of the terminal blocks in which two connection wires can be installed

## Overview

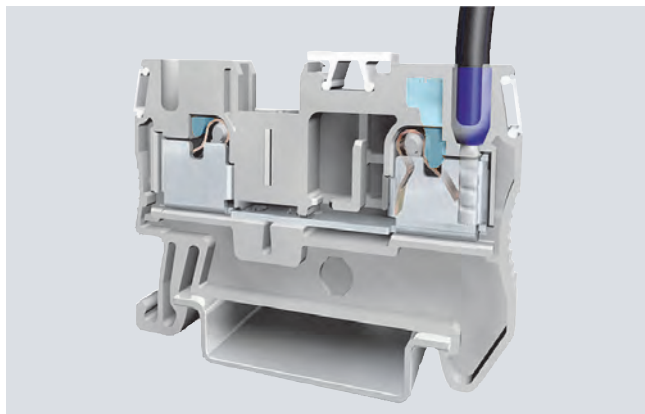

iPo connection method: Characterized by its simple and direct conductor connection, this series utilizes all the benefits of the 8WH system.

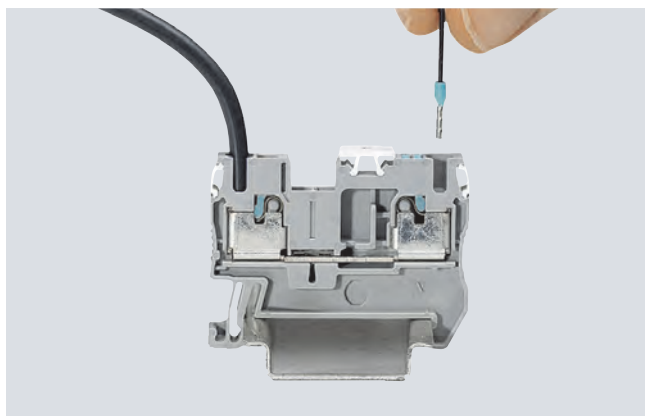

Super-light insertion: With an up to 50% lower insertion force, the iPo connection method permits easy and direct insertion of rigid and flexible conductors with end sleeves with a cross-section of more than  $0.34 \text{ mm}^2$ .

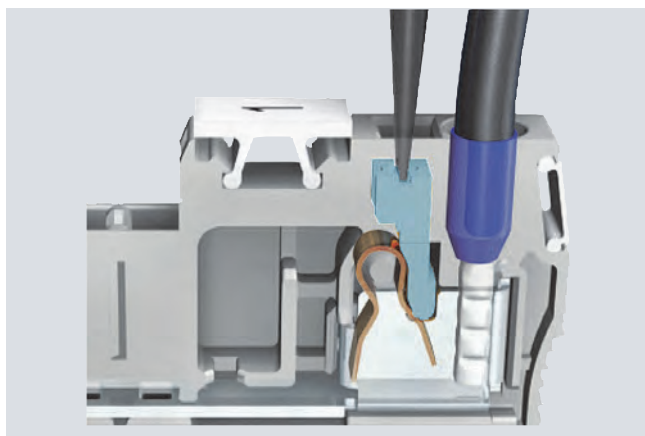

Pusher button function: The actuation button is used to open the spring to either release the conductor or to connect smaller cross-sections from  $0.14 \text{ mm}^2$ . It can be operated by any tool.

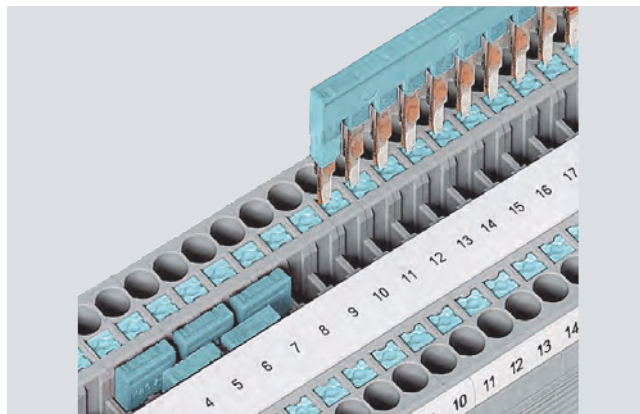

Easy bridging: The double bridge shaft supports the interconnection of any number of terminals using 2-pole jumpers. The 2-pole to 50-pole jumpers enable up to 50 terminals to be connected in a single step.

### 8WH6 through-type terminals

#### Overview



8WH6 through-type terminals are ideal for the direct tool-free wiring of conductors with end sleeve or rigid conductors. Easy insertion of flexible conductors with end sleeves upwards of 0.34 mm<sup>2</sup>. The actuation button can be used to open the clamping point with any type of screwdriver in order to unwire or wire small conductors. The compact design and front connection permit wiring in the narrowest of spaces. The double bridge shaft enables fast creation of an individual potential distribution and infeed, e.g. using a screw terminal.

A label can be snapped on to the middle of each terminal at the front. Further labels can also be mounted flat on the side of the terminals.

#### Technical specifications

	8WH6 000-0AF00 8WH6 000-0AF01	8WH6 003-0AF00 8WH6 003-0AF01	8WH6 004-0AF00 8WH6 004-0AF01
Dimensions			
• Width/length/height (NS 35/7.5) in mm	5.2 / 48.5 / 36.5	5.2 / 60.5 / 36.5	5.2 / 72 / 36.5
Max. electrical data			
• $I_{max}$ in A	30	30 <sup>1)</sup>	
• $U_{max}$ in V	800		
• Max. Ø in mm <sup>2</sup>	0.14 ... 4		
• AWG	26-12		
Rating according to IEC 60947-7-1			
• Rated voltage in V (IEC / UL/CSA)	800 / 600		800 / --
• Rated current in A / cross-section in mm <sup>2</sup>			
- IEC	24 / 2.5	24 <sup>1)</sup> / 2.5	
- UL/CSA	20 / --		--
• Nominal cross-section in mm <sup>2</sup>	2.5		
• AWG cross-section range (IEC / UL/CSA)	26-12 / 24-12		26-12 / --
Connection capacities			
• 1 conductor			
- Rigid in mm <sup>2</sup>	0.14 ... 4		
- Flexible in mm <sup>2</sup>	0.14 ... 2.5		
- Flexible end sleeve with/without plastic sleeve in mm <sup>2</sup>	0.14 ... 2.5		
• Conductor cross-section, direct plug-in			
- Rigid in mm <sup>2</sup>	0.34 ... 4		
- Flexible end sleeve with/without plastic sleeve in mm <sup>2</sup>	0.34 ... 2.5		
General data			
• Stripped length in mm	10		
• Molded plastic	PA		
• Flammability class acc. to UL 94	V0		

<sup>1)</sup> The total current through all connected conductors must not exceed the max. load current.

	8WH6 000-0CF07	8WH6 003-0CF07	8WH6 004-0CF07
Dimensions			
• Width/length/height (NS 35/7.5) in mm	5.2 / 48.5 / 36.5	5.2 / 60.5 / 36.5	5.2 / 72 / 36.5
Max. electrical data			
• Max. Ø in mm <sup>2</sup>	0.14 ... 4		
• AWG	26-12		
Rating according to IEC 60947-7-1			
• Nominal cross-section in mm <sup>2</sup>	2.5		
• AWG cross-section range (IEC / UL/CSA)	26-12 / 24-12		26-12 / --
Connection capacities			
• 1 conductor			
- Rigid in mm <sup>2</sup>	0.14 ... 4		
- Flexible end sleeve with/without plastic sleeve in mm <sup>2</sup>	0.14 ... 2.5		
• Conductor cross-section, direct plug-in			
- Rigid in mm <sup>2</sup>	0.34 ... 4		
- Flexible end sleeve with/without plastic sleeve in mm <sup>2</sup>	0.34 ... 2.5		
General data			
• Stripped length in mm	10		
• Molded plastic	PA		
• Flammability Class acc. to UL 94	V0		

	8WH6 000-0AG00 8WH6 000-0AG01	8WH6 003-0AG00 8WH6 003-0AG01	8WH6 004-0AG00 8WH6 004-0AG01
Dimensions			
• Width/length/height in mm	6.2 / 56 / 36.5	6.2 / 66.5 / 36.5	6.2 / 77 / 36.5
Max. electrical data			
• $I_{max}$ in A	38	38 <sup>1)</sup>	38 <sup>1)</sup>
• $U_{max}$ in V	800	800	800
• Max. Ø in mm <sup>2</sup>	0.2 ... 6	0.2 ... 6	0.2 ... 6
• AWG	24-10	24-10	24-10
Rating according to IEC 60947-7-1			
• Rated voltage in V (IEC / UL/CSA)	800 / 600	800 / 600	800 / 600
• Rated current in A / cross-section in mm <sup>2</sup>			
- IEC	32/ 4	32 <sup>1)</sup> / 4	32 <sup>1)</sup> / 4
- UL/CSA	30 / --	30 / --	30 / --
• Nominal cross-section in mm <sup>2</sup>	4	4	4
• AWG cross-section range (IEC / UL/CSA)	24-10 / 24-10	24-10 / 24-10	24-10 / 24-10
Connection capacities			
• 1 conductor			
- Rigid in mm <sup>2</sup>	0.2 ... 6	0.2 ... 6	0.2 ... 6
- Flexible in mm <sup>2</sup>	0.2 ... 4	0.2 ... 4	0.2 ... 4
- Flexible end sleeve with/without plastic sleeve in mm <sup>2</sup>	0.25 ... 4	0.25 ... 4	0.25 ... 4
• Conductor cross-section, direct plug-in			
- Rigid in mm <sup>2</sup>	0.5 ... 6	0.2 ... 6	0.5 ... 6
- Flexible end sleeve with/without plastic sleeve in mm <sup>2</sup>	0.5 ... 4	0.5 ... 4	0.5 ... 4
General data			
• Stripped length in mm	12	12	12
• Molded plastic	PA	PA	PA
• Flammability Class acc. to UL 94	V0	V0	V0

1) The total current through all connected conductors must not exceed the max. load current.





	8WH6 000-0CG07	8WH6 003-0CG07	8WH6 004-0CG07
Dimensions			
• Width/length/height (NS 35/7.5) in mm	6.2 / 56 / 36.5	6.2 / 66.5 / 36.5	6.2 / 77 / 36.5
Max. electrical data			
• Max. Ø in mm <sup>2</sup>	0.2 ... 6	0.2 ... 6	0.2 ... 6
• AWG	24-10	24-10	24-10
Rating according to IEC 60947-7-1			
• Nominal cross-section in mm <sup>2</sup>	4	4	4
• AWG cross-section range (IEC / UL/CSA)	24-10 / 24-10	24-10 / 24-10	24-10 / 24-10
Connection capacities			
• 1 conductor			
- Rigid in mm <sup>2</sup>	0.2 ... 6	0.2 ... 6	0.2 ... 6
- Flexible end sleeve with/without plastic sleeve in mm <sup>2</sup>	0.25 ... 4	0.2 ... 4	0.2 ... 4
• Conductor cross-section, direct plug-in			
- Rigid in mm <sup>2</sup>	0.5 ... 6		
- Flexible end sleeve with/without plastic sleeve in mm <sup>2</sup>	0.5 ... 4		
General data			
• Stripped length in mm	12	12	12
• Molded plastic	PA	PA	PA
• Flammability Class acc. to UL 94	V0	V0	V0

# 8WH6 iPo Plug-In Terminals



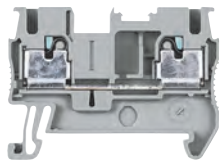
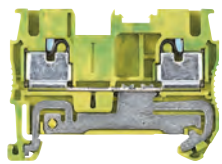









2

## 8WH6 through-type terminals

### Selection and ordering data

Version	Order No.	MOQ*
<b>Terminal size 2.5 mm<sup>2</sup></b>		
 <p>8WH6 000-0AF00</p> <p><b>Through-type terminals, terminal size 2.5 mm<sup>2</sup></b></p> <ul style="list-style-type: none"> <li>• <math>C_{UL}</math></li> <li>• Terminal width 5.2 mm</li> <li>• <math>I_{max} = 30</math> A</li> <li>• <math>U_{max} = 800</math> V</li> <li>• AWG 26-12</li> <li>• Connection capacity, one conductor               <ul style="list-style-type: none"> <li>- Rigid 0.14 ... 4 mm<sup>2</sup></li> <li>- Flexible 0.14 ... 2.5 mm<sup>2</sup></li> </ul> </li> </ul> <p>Versions</p> <ul style="list-style-type: none"> <li>• Two clamping points               <ul style="list-style-type: none"> <li>- Gray</li> <li>- Blue</li> </ul> </li> <li>• Three clamping points               <ul style="list-style-type: none"> <li>- Gray</li> <li>- Blue</li> </ul> </li> <li>• Four clamping points               <ul style="list-style-type: none"> <li>- Gray</li> <li>- Blue</li> </ul> </li> </ul>	<p><b>8WH6 000-0AF00</b></p> <p><b>8WH6 000-0AF01</b></p> <p><b>8WH6 003-0AF00</b></p> <p><b>8WH6 003-0AF01</b></p> <p><b>8WH6 004-0AF00</b></p> <p><b>8WH6 004-0AF01</b></p>	<p>50 units</p> <p>50 units</p> <p>50 units</p> <p>50 units</p> <p>50 units</p> <p>50 units</p>
 <p>8WH6 000-0CF07</p> <p><b>PE through-type terminals, terminal size 2.5 mm<sup>2</sup></b></p> <ul style="list-style-type: none"> <li>• <math>C_{UL}</math></li> <li>• Terminal width 5.2 mm</li> <li>• AWG 26-12</li> <li>• Connection capacity, one conductor               <ul style="list-style-type: none"> <li>- Rigid 0.14 ... 4 mm<sup>2</sup></li> <li>- Flexible 0.14 ... 2.5 mm<sup>2</sup></li> </ul> </li> <li>• Green/yellow</li> </ul> <p>Versions</p> <ul style="list-style-type: none"> <li>• Two clamping points</li> <li>• Three clamping points</li> <li>• Four clamping points</li> </ul>	<p><b>8WH6 000-0CF07</b></p> <p><b>8WH6 003-0CF07</b></p> <p><b>8WH6 004-0CF07</b></p>	<p>50 units</p> <p>50 units</p> <p>50 units</p>
<b>Accessories</b>		
 <p><b>Covers, for terminal sizes 1.5 ... 2.5 mm<sup>2</sup></b></p> <p>Width 2.2 mm</p> <p>Versions</p> <ul style="list-style-type: none"> <li>• For two clamping points</li> <li>• For three clamping points</li> <li>• For four clamping points</li> </ul>	<p><b>8WH9 000-1GA00</b></p> <p><b>8WH9 000-2GA00</b></p> <p><b>8WH9 000-4GA00</b></p>	<p>50 units</p> <p>50 units</p> <p>50 units</p>
 <p>8WH9 000-0GA00</p> <p><b>Cover segments, for terminal size 1.5 ... 2.5 mm<sup>2</sup></b></p> <p>For covering multi-wire terminals when mounting two-wire terminals side-by-side</p>	<p><b>8WH9 000-0GA00</b></p>	<p>10 units</p>
 <p>8WH9 070-0AA00</p> <p><b>Compartment partitions, for terminal size 1.5 ... 4 mm<sup>2</sup></b></p> <ul style="list-style-type: none"> <li>• For visual and electrical separation of terminal groups</li> <li>• 2 mm thick</li> <li>• Gray</li> </ul> <p>Versions</p> <ul style="list-style-type: none"> <li>• For two clamping points</li> <li>• For three clamping points</li> <li>• For four clamping points</li> </ul> <p>Note</p> <p>For general accessories for 8WH terminal blocks, <a href="#">see chapter 8</a></p>	<p><b>8WH9 070-0AA00</b></p> <p><b>8WH9 070-0GA00</b></p> <p><b>8WH9 070-0HA00</b></p>	<p>50 units</p> <p>50 units</p> <p>50 units</p>

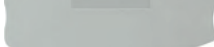
## 8WH6 through-type terminals

Version	Order No.	MOQ*
<b>Terminal size 4 mm<sup>2</sup></b>		
 <p>8WH6 000-0AG00</p>  <p>8WH6 003-0AG00</p>  <p>8WH6 003-0AG01</p>  <p>8WH6 004-0AG00</p>  <p>8WH6 004-0AG01</p>	<p><b>Through-type terminals, terminal size 4 mm<sup>2</sup></b></p> <ul style="list-style-type: none"> <li>•  US</li> <li>• Terminal width 6.2 mm</li> <li>• <math>I_{max} = 38</math> A</li> <li>• <math>U_{max} = 800</math> V</li> <li>• AWG 24-10</li> <li>• Connection capacity, one conductor                     <ul style="list-style-type: none"> <li>- Rigid 0.2 ... 6 mm<sup>2</sup></li> <li>- Flexible 0.2 ... 4 mm<sup>2</sup></li> </ul> </li> </ul> <p>Versions</p> <ul style="list-style-type: none"> <li>• Two clamping points                     <ul style="list-style-type: none"> <li>- Gray</li> <li>- Blue</li> </ul> </li> <li>• Three clamping points                     <ul style="list-style-type: none"> <li>- Gray</li> <li>- Blue</li> </ul> </li> <li>• Four clamping points                     <ul style="list-style-type: none"> <li>- Gray</li> <li>- Blue</li> </ul> </li> </ul>	<p><b>8WH6 000-0AG00</b> 50 units  <b>8WH6 000-0AG01</b> 50 units</p> <p><b>8WH6 003-0AG00</b> 50 units  <b>8WH6 003-0AG01</b> 50 units</p> <p><b>8WH6 004-0AG00</b> 50 units  <b>8WH6 004-0AG01</b> 50 units</p>
<b>PE through-type terminal, terminal size 4 mm<sup>2</sup></b>		
 <p>8WH6 000-0CG07</p>  <p>8WH6 003-0CG07</p>  <p>8WH6 004-0CG07</p>	<ul style="list-style-type: none"> <li>•  US</li> <li>• Terminal width 6.2 mm</li> <li>• AWG 24-10</li> <li>• Connection capacity, one conductor                     <ul style="list-style-type: none"> <li>- Rigid 0.2 ... 6 mm<sup>2</sup></li> <li>- Flexible 0.2 ... 4 mm<sup>2</sup></li> </ul> </li> <li>• Green/yellow</li> </ul> <p>Versions</p> <ul style="list-style-type: none"> <li>• Two clamping points</li> <li>• Three clamping points</li> <li>• Four clamping points</li> </ul>	<p><b>8WH6 000-0CG07</b> 50 units  <b>8WH6 003-0CG07</b> 50 units  <b>8WH6 004-0CG07</b> 50 units</p>
<b>Accessories</b>		
<b>Covers, for terminal size 4 mm<sup>2</sup></b>		
 <p>8WH9 003-1GA00</p>	<p>Width 2.2 mm</p> <p>Versions</p> <ul style="list-style-type: none"> <li>• For two clamping points</li> <li>• For three clamping points</li> <li>• For four clamping points</li> </ul>	<p><b>8WH9 003-1GA00</b> 50 units  <b>8WH9 003-2SA00</b> 50 units  <b>8WH9 003-4SA00</b> 50 units</p>
<b>Compartment partitions, for terminal size 1.5 ... 4 mm<sup>2</sup></b>		
 <p>8WH9 070-0AA00</p>	<ul style="list-style-type: none"> <li>• For visual and electrical separation of terminal groups</li> <li>• 2 mm thick</li> <li>• Gray</li> </ul> <p>Versions</p> <ul style="list-style-type: none"> <li>• For two clamping points</li> <li>• For three clamping points</li> <li>• For four clamping points</li> </ul>	<p><b>8WH9 070-0AA00</b> 50 units  <b>8WH9 070-0GA00</b> 50 units  <b>8WH9 070-0HA00</b> 50 units</p>

Note:

For general accessories for 8WH terminal blocks, [see chapter 8](#).

\* You can order this quantity or a multiple thereof.



## Overview



Through-type terminals with isolating blade capability are the most commonly used terminal types in measuring and control technology. Key features of the 8WH6 isolating blade terminals are the slim design of only 5.2 mm and their high current-carrying capacity. Convenient testing is made possible by the integral double function shaft located on one side of the isolating point and the integrated test contact located on the other. Standard connecting combs allow easy execution of all potential-distribution tasks. Three and four-wire terminals up to 2.5 mm<sup>2</sup> are available for the multi-conductor connection.

A label can be snapped on to the middle of each terminal at the front. Further labels can also be mounted flat on the side of the terminals.

## Technical specifications

	8WH6 000-6AF00	8WH6 003-6AF00	8WH6 004-6AF00
Dimensions			
• Width/length/height (NS 35/7.5) in mm	5.2 / 60.5 / 36.5	5.2 / 74 / 36.5	5.2 / 84 / 36.5
Max. electrical data			
• $I_{max}$ in A	20	20 <sup>1)</sup>	
• $U_{max}$ in V	400		
• Max. Ø in mm <sup>2</sup>	0.14 ... 4		
• AWG	26-12		
Rating according to IEC 60947-7-1			
• Rated voltage in V (IEC)	400		
• Rated current in A / cross-section in mm <sup>2</sup> (IEC)	20 / 2.5	20 <sup>1)</sup> / 2.5	
• Nominal cross-section in mm <sup>2</sup>	2.5		
• AWG cross-section range (IEC)	26-12		
Connection capacities			
• 1 conductor			
- Rigid in mm <sup>2</sup>	0.14 ... 4		
- Flexible in mm <sup>2</sup>	0.14 ... 2.5		
- Flexible end sleeve with/without plastic sleeve in mm <sup>2</sup>	0.14 ... 2.5		
• Conductor cross-section, direct plug-in			
- Rigid in mm <sup>2</sup>	0.34 ... 4		
- Flexible end sleeve with/without plastic sleeve in mm <sup>2</sup>	0.34 ... 2.5		
General data			
• Stripped length in mm	10		
• Molded plastic	PA		
• Flammability class acc. to UL 94	V0		

1) The total current through all connected conductors must not exceed the max. load current.





	8WH6 000-6AG00
Dimensions	
• Width/length/height (NS 35/7.5) in mm	6.2 / 54 / 36.5
Max. electrical data	
• $I_{max}$ in A	20
• $U_{max}$ in V	400
• Max. Ø in mm <sup>2</sup>	0.2 ... 6
• AWG	24-10
Rating according to IEC 60947-7-1	
• Rated voltage in V (IEC / UL/CSA)	400 / 300
• Rated current in A / cross-section in mm <sup>2</sup>	
- IEC	20 / 2.5
- UL/CSA	20 / --
• Nominal cross-section in mm <sup>2</sup>	4
• AWG cross-section range (IEC / UL/CSA)	24-10 / 24-10
Connection capacities	
• 1 conductor	
- Rigid in mm <sup>2</sup>	0.2 ... 6
- Flexible in mm <sup>2</sup>	0.2 ... 4
- Flexible end sleeve with/without plastic sleeve in mm <sup>2</sup>	0.25 ... 4
• Conductor cross-section, direct plug-in	
- Rigid in mm <sup>2</sup>	0.5 ... 6
- Flexible end sleeve with/without plastic sleeve in mm <sup>2</sup>	0.5 ... 4
General data	
• Stripped length in mm	12
• Molded plastic	PA
• Flammability class acc. to UL 94	V0

# 8WH6 iPo Plug-In Terminals

2

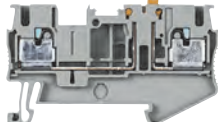
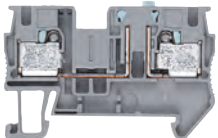
## 8WH6 isolating blade terminals

### Selection and ordering data

Version	Order No.	MOQ*
<b>Terminal size 2.5 mm<sup>2</sup></b>		
 <p>8WH6 000-6AF00</p> <p><b>Isolating blade terminals, terminal size 2.5 mm<sup>2</sup></b></p> <ul style="list-style-type: none"> <li>Terminal width 5.2 mm</li> <li><math>I_{max} = 20</math> A</li> <li><math>U_{max} = 400</math> V</li> <li>AWG 26-12</li> <li>Connection capacity, one conductor                             <ul style="list-style-type: none"> <li>Rigid 0.14 ... 4 mm<sup>2</sup></li> <li>Flexible 0.14 ... 2.5 mm<sup>2</sup></li> </ul> </li> </ul> <p><b>Versions</b></p> <ul style="list-style-type: none"> <li>Two clamping points</li> <li>Three clamping points</li> <li>Four clamping points</li> </ul>	<p><b>8WH6 000-6AF00</b></p> <p><b>8WH6 003-6AF00</b></p> <p><b>8WH6 004-6AF00</b></p>	<p>50 units</p> <p>50 units</p> <p>50 units</p>
<b>Terminal size 4 mm<sup>2</sup></b>		
 <p>8WH6 000-6CG00</p> <p><b>Isolating blade terminals, terminal size 4 mm<sup>2</sup></b></p> <ul style="list-style-type: none"> <li>With 2 clamping points</li> <li>Terminal width 6.2 mm</li> <li><math>I_{max} = 20</math> A</li> <li><math>U_{max} = 400</math> V</li> <li>AWG 24-10</li> <li>Connection capacity, one conductor                             <ul style="list-style-type: none"> <li>Rigid 0.2 ... 6 mm<sup>2</sup></li> <li>Flexible 0.2 ... 4 mm<sup>2</sup></li> </ul> </li> <li>Connection capacity, two conductors                             <ul style="list-style-type: none"> <li>Rigid 0.5 ... 6 mm<sup>2</sup></li> </ul> </li> </ul>	<p><b>8WH6 000-6CG00</b></p>	<p>50 units</p>
<b>Accessories</b>		
 <p>8WH9 000-3SC00</p> <p><b>Covers, for terminal size 2.5 mm<sup>2</sup></b></p> <p>Width 2.2 mm</p> <ul style="list-style-type: none"> <li>For two clamping points</li> <li>For three clamping points</li> <li>For four clamping points</li> </ul>	<p><b>8WH9 000-3SC00</b></p> <p><b>8WH9 000-3SD00</b></p> <p><b>8WH9 000-5GA00</b></p>	<p>50 units</p> <p>50 units</p> <p>50 units</p>
 <p>8WA9 003-1GA00</p> <p><b>Covers, for terminal size 4 mm<sup>2</sup></b></p> <ul style="list-style-type: none"> <li>For two clamping points</li> <li>Width 2.2 mm</li> </ul>	<p><b>8WH9 003-1GA00</b></p>	<p>50 units</p>
 <p>8WH9 070-0AA00</p> <p><b>Compartment partitions, for terminal size 1.5 ... 4 mm<sup>2</sup></b></p> <ul style="list-style-type: none"> <li>For two clamping points</li> <li>For visual and electrical separation of terminal groups</li> <li>2 mm thick</li> <li>Gray</li> </ul>	<p><b>8WH9 070-0AA00</b></p>	<p>50 units</p>

Note:

For general accessories for 8WH terminal blocks, [see chapter 8](#).

## Overview

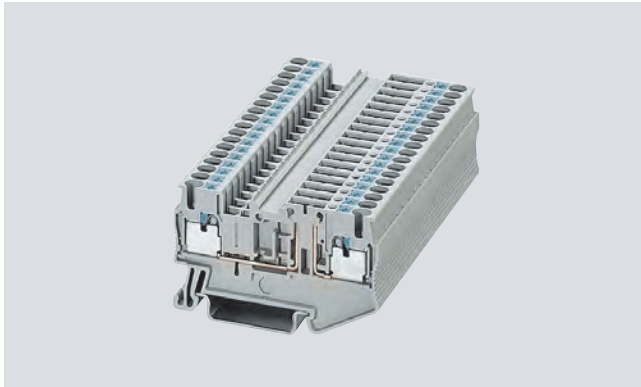

8WH6 isolating terminals in iPo connection technology are available for special wiring tasks. With the same contour as the isolating blade terminals, 8WH6 isolating terminals are fitted with a universal plug-in zone in the middle of the terminal. Numerous wiring tasks can be performed on a terminal width of 5.2 mm by integrating the isolated through-type connector, the isolating plug, the component connector or the fused plug.

A label can be snapped on to the middle of each terminal at the front. Further labels can also be mounted flat on the side of the terminals.

## Technical specifications

	8WH6 000-6CF00	8WH6 003-6CF00	8WH6 004-6CF00
<b>Dimensions</b>			
• Width/length/height (NS 35/7.5) in mm	5.2 / 60.5 / 36.5	5.2 / 74 / 36.5	5.2 / 84 / 36.5
<b>Max. electrical data</b>			
• $I_{max}$ in A	20	20 <sup>1)</sup>	
• $U_{max}$ in V	400 <sup>2)</sup>		
• Max. Ø in mm <sup>2</sup>	0.14 ... 4		
• AWG	26-12		
<b>Rating according to IEC 60947-7-1</b>			
• Rated voltage in V (IEC)	400 <sup>2)</sup>		
• Rated current in A / cross-section in mm <sup>2</sup> (IEC)	20 / 2.5	20 <sup>1)</sup> / 2.5	
• Nominal cross-section in mm <sup>2</sup> (IEC)	2.5		
• AWG cross-section range (IEC)	26-12		
<b>Connection capacities</b>			
• 1 conductor			
- Rigid in mm <sup>2</sup>	0.14 ... 4		
- Flexible in mm <sup>2</sup>	0.14 ... 2.5		
- Flexible end sleeve with/without plastic sleeve in mm <sup>2</sup>	0.14 ... 2.5		
• Conductor cross-section, direct plug-in			
- Rigid in mm <sup>2</sup>	0.34 ... 4		
- Flexible end sleeve with/without plastic sleeve in mm <sup>2</sup>	0.34 ... 2.5		
<b>General data</b>			
• Stripped length in mm	10		
• Molded plastic	PA		
• Flammability class acc. to UL 94	V0		
	<b>8WH6 000-6CG00</b>		
<b>Dimensions</b>			
• Width/length/height (NS 35/7.5) in mm	6.2 / 56 / 36.5		
<b>Max. electrical data</b>			
• $I_{max}$ in A	20		
• $U_{max}$ in V	400 <sup>2)</sup>		
• Max. Ø in mm <sup>2</sup>	0.2 ... 6		
• AWG	24-10		
<b>Rating according to IEC 60947-7-1</b>			
• Rated voltage in V (IEC / UL/CSA)	400 / 300		
• Rated current in A / cross-section in mm <sup>2</sup>			
- IEC	20 / 2.5		
- UL/CSA	20 / --		
• Nominal cross-section in mm <sup>2</sup>	4		
• AWG cross-section range (IEC / UL/CSA)	24-10 / 24-10		
<b>Connection capacities</b>			
• 1 conductor			
- Rigid in mm <sup>2</sup>	0.2 ... 6		
- Flexible in mm <sup>2</sup>	0.25 ... 4		
- Flexible end sleeve with/without plastic sleeve in mm <sup>2</sup>	0.25 ... 4		
• Conductor cross-section, direct plug-in			
- Rigid in mm <sup>2</sup>	0.5 ... 6		
- Flexible end sleeve with/without plastic sleeve in mm <sup>2</sup>	0.5 ... 4		
<b>General data</b>			
• Stripped length in mm	12		
• Molded plastic	PA		
• Flammability class acc. to UL 94	V0		

<sup>1)</sup> The total current through all connected conductors must not exceed the max. load current.





<sup>2)</sup> Current and voltage are determined by the fitted plug.

# 8WH6 iPo Plug-In Terminals

2

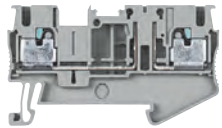
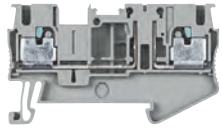
## 8WH6 isolating terminals

### Selection and ordering data

Version	Order No.	MOQ*
<b>Terminal size 2.5 mm<sup>2</sup></b>		
 <p>8WH6 000-6CF00</p> <p><b>Isolating terminals, terminal size 2.5 mm<sup>2</sup></b></p> <ul style="list-style-type: none"> <li>Terminal width 5.2 mm</li> <li><math>I_{max} = 20</math> A</li> <li><math>U_{max} = 400</math> V</li> <li>AWG 26-12</li> <li>Connection capacity, one conductor                             <ul style="list-style-type: none"> <li>Rigid 0.14 ... 4 mm<sup>2</sup></li> <li>Flexible 0.14 ... 2.5 mm<sup>2</sup></li> </ul> </li> </ul> <p><b>Versions</b></p> <ul style="list-style-type: none"> <li>Two clamping points</li> <li>Three clamping points</li> <li>Four clamping points</li> </ul>	<p><b>8WH6 000-6CF00</b></p> <p><b>8WH6 003-6CF00</b></p> <p><b>8WH6 004-6CF00</b></p>	<p>50 units</p> <p>50 units</p> <p>50 units</p>
<b>Terminal size 4 mm<sup>2</sup></b>		
 <p>8WH6 000-6AG00</p> <p><b>Isolating terminals, terminal size 4 mm<sup>2</sup></b></p> <ul style="list-style-type: none"> <li>With two clamping points</li> <li>Terminal width 6.2 mm</li> <li><math>I_{max} = 20</math> A</li> <li><math>U_{max} = 400</math> V</li> <li>AWG 24-10</li> <li>Connection capacity, one conductor                             <ul style="list-style-type: none"> <li>Rigid 0.2 ... 6 mm<sup>2</sup></li> <li>Flexible 0.2 ... 4 mm<sup>2</sup></li> </ul> </li> </ul>	<p><b>8WH6 000-6AG00</b></p>	<p>50 units</p>
<b>Accessories</b>		
 <p>8WH9 000-3SC00</p> <p><b>Covers, for terminal size 2.5 mm<sup>2</sup></b></p> <p>Width 2.2 mm</p> <ul style="list-style-type: none"> <li>For two clamping points</li> <li>For three clamping points</li> <li>For four clamping points</li> </ul>	<p><b>8WH9 000-3SC00</b></p> <p><b>8WH9 000-3SD00</b></p> <p><b>8WH9 000-5GA00</b></p>	<p>50 units</p> <p>50 units</p> <p>50 units</p>
 <p>8WA9 003-1GA00</p> <p><b>Covers, for terminal size 4 mm<sup>2</sup></b></p> <ul style="list-style-type: none"> <li>For two clamping points</li> <li>Width 2.2 mm</li> </ul>	<p><b>8WH9 003-1GA00</b></p>	<p>50 units</p>
 <p>8WH9 070-0AA00</p> <p><b>Compartment partitions, for terminal size 1.5 ... 4 mm<sup>2</sup></b></p> <ul style="list-style-type: none"> <li>For two clamping points</li> <li>For visual and electrical separation of terminal groups</li> <li>2 mm thick</li> <li>Gray</li> </ul>	<p><b>8WH9 070-0AA00</b></p>	<p>50 units</p>
 <p>8WH9 070-0GA00</p> <p><b>Compartment partitions, for terminal size 1.5 ... 4 mm<sup>2</sup></b></p> <ul style="list-style-type: none"> <li>For three clamping points</li> <li>For visual and electrical separation of terminal groups</li> <li>2 mm thick</li> <li>Gray</li> </ul>	<p><b>8WH9 070-0GA00</b></p>	<p>50 units</p>

Note:

For general accessories for 8WH terminal blocks, [see chapter 8](#).

## Overview

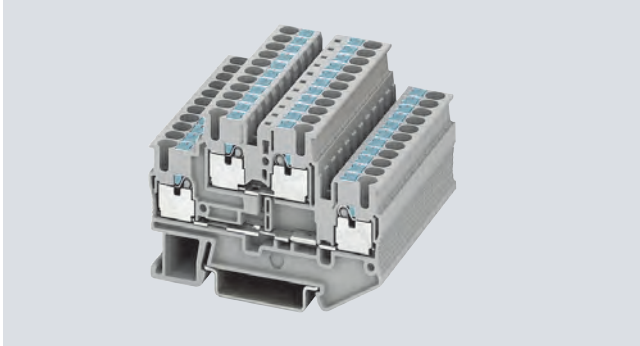

With the two voltage levels routed through two tiers, the 8WH6 two-tier terminals require 50% less space than equivalent single-tier terminals. To implement a wide range of wiring tasks, connecting combs can be fitted to both tiers of the two-tier terminal series. Facilities for inscription are provided at each clamping point.

Two-tier terminals with equipotential bonding for the upper and lower tiers are also available.

With the same contour as 8WH6 two-tier terminals, 8WH6 two-tier PE terminals round off the product range. Perfect mechanical and electrical contact with the support rail is provided by simply snapping the terminals onto the rail. 8WH6 PE two-tier terminals comply with all the requirements of IEC 60947-7-2. These include in particular:

- Low contact resistance
- Stainless clamping points
- Green-yellow enclosure
- Additional inscription options.

A label can be mounted flat at each clamping point by simply snapping it on.

## Technical specifications

	8WH6 020-0AF00 8WH6 020-0AF01	8WH6 025-0AF00	8WH6 020-0CF07	8WH6 020-0AG00 8WH6 020-0AG01	8WH6 025-0AG00	8WH6 020-0CG07
Dimensions • Width/length/height (NS 35/7.5) in mm	5.2 / 68 / 47.5	5.2 / 78 / 55		6.2 / 83.5 / 47.5		
Max. electrical data • $I_{max}$ in A • $U_{max}$ in V • Max. Ø in mm <sup>2</sup> • AWG	26 500 0.14 ... 4 26-12	26 <sup>1)</sup>	-- --	32 500 0.2 ... 6 24-10		-- --
Rating according to IEC 60947-7-1 • Rated voltage in V (IEC) • Rated current in A / cross-section in mm <sup>2</sup> - IEC - UL/CSA • Nominal cross-section in mm <sup>2</sup> (IEC) • AWG cross-section range (IEC)	500  20 / 2.5 2.5 26-12	  20 <sup>1)</sup> / 2.5	-- -- / --	500 / 600  30 / -- 4 24-10 / 24-10		-- -- / -- -- / --
Connection capacities • 1 conductor - Rigid in mm <sup>2</sup> - Flexible in mm <sup>2</sup> - Flexible end sleeve with/without plastic sleeve in mm <sup>2</sup> • Conductor cross-section, direct plug-in - Rigid in mm <sup>2</sup> - Flexible end sleeve with/without plastic sleeve in mm <sup>2</sup>	 0.14 ... 4 0.14 ... 2.5 0.14 ... 2.5  0.34 ... 4 0.34 ... 2.5			 0.2 ... 6 0.2 ... 4 0.25 ... 4  0.5 ... 6 0.5 ... 4		
General data • Stripped length in mm • Molded plastic • Flammability class acc. to UL 94	10 PA V0			12 PA V0		







<sup>1)</sup> The total current through all connected conductors must not exceed the max. load current.

# 8WH6 iPo Plug-In Terminals

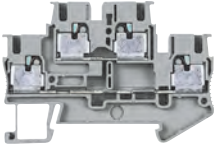
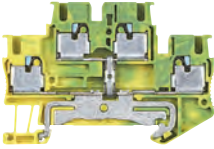
2

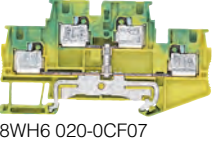
## 8WH6 two-tier terminals

### Selection and ordering data

Version	Order No.	MOQ*
<b>Terminal size 2.5 mm<sup>2</sup></b>		
 <p>8WH6 020-0AF00</p> <p><b>Two-tier terminals, terminal size 2.5 mm<sup>2</sup></b></p> <ul style="list-style-type: none"> <li>Terminal width 5.2 mm</li> <li><math>I_{max} = 26</math> A</li> <li><math>U_{max} = 500</math> V</li> <li>AWG 26-12</li> <li>Connection capacity, one conductor                             <ul style="list-style-type: none"> <li>Rigid 0.14 ... 4 mm<sup>2</sup></li> <li>Flexible 0.14 ... 2.5 mm<sup>2</sup></li> </ul> </li> </ul> <p><b>Versions</b></p> <ul style="list-style-type: none"> <li>Without equipotential bonding                             <ul style="list-style-type: none"> <li>Gray</li> <li>Blue</li> </ul> </li> <li>With equipotential bonding</li> </ul>	<p><b>8WH6 020-0AF00</b></p> <p><b>8WH6 020-0AF01</b></p> <p><b>8WH6 025-0AF00</b></p>	<p>50 units</p> <p>50 units</p> <p>50 units</p>
 <p>8WH6 020-0CF07</p> <p><b>PE two-tier terminals, terminal size 2.5 mm<sup>2</sup></b></p> <ul style="list-style-type: none"> <li>Terminal width 5.2 mm</li> <li>AWG 26-12</li> <li>Connection capacity, one conductor                             <ul style="list-style-type: none"> <li>Rigid 0.14 ... 4 mm<sup>2</sup></li> <li>Flexible 0.14 ... 2.5 mm<sup>2</sup></li> </ul> </li> <li>Green/yellow</li> </ul> <p><b>Note</b></p> <p>Bridging the terminal is only possible in the top level (central).</p>	<p><b>8WH6 020-0CF07</b></p>	<p>50 units</p>
<b>Terminal size 4 mm<sup>2</sup></b>		
 <p>8WH6 025-0AG00</p> <p><b>Two-tier terminals, terminal size 4 mm<sup>2</sup></b></p> <ul style="list-style-type: none"> <li>Terminal width 6.2 mm</li> <li><math>I_{max} = 32</math> A</li> <li><math>U_{max} = 500</math> V</li> <li>AWG 24-10</li> <li>Connection capacity, one conductor                             <ul style="list-style-type: none"> <li>Rigid 0.2 ... 6 mm<sup>2</sup></li> <li>Flexible 0.2 ... 4 mm<sup>2</sup></li> </ul> </li> </ul> <p><b>Versions</b></p> <ul style="list-style-type: none"> <li>Without equipotential bonding                             <ul style="list-style-type: none"> <li>Gray</li> <li>Blue</li> </ul> </li> <li>With equipotential bonding</li> </ul>	<p><b>8WH6 020-0AG00</b></p> <p><b>8WH6 020-0AG01</b></p> <p><b>8WH6 025-0AG00</b></p>	<p>50 units</p> <p>50 units</p> <p>50 units</p>
 <p>8WH6 020-0CF07</p> <p><b>PE two-tier terminals, terminal size 4 mm<sup>2</sup></b></p> <ul style="list-style-type: none"> <li>Terminal width 6.2 mm</li> <li>AWG 24-10</li> <li>Connection capacity, one conductor                             <ul style="list-style-type: none"> <li>Rigid 0.2 ... 6 mm<sup>2</sup></li> <li>Flexible 0.2 ... 4 mm<sup>2</sup></li> </ul> </li> <li>Green/yellow</li> </ul> <p><b>Note</b></p> <p>Bridging the terminal is only possible in the top level (central).</p>	<p><b>8WH6 020-0CF07</b></p>	<p>50 units</p>
<b>Accessories</b>		
 <p>8WH9 000-4SE00</p> <p><b>Covers, for terminal sizes 1.5 ... 2.5 mm<sup>2</sup></b></p> <ul style="list-style-type: none"> <li>Width 2.2 mm</li> <li>Gray</li> </ul>	<p><b>8WH9 000-4SE00</b></p>	<p>50 units</p>
 <p>8WH9 003-1VA00</p> <p><b>Covers, for terminal sizes 1.5 ... 4 mm<sup>2</sup></b></p> <ul style="list-style-type: none"> <li>For two clamping points</li> <li>Width 2.2 mm</li> </ul>	<p><b>8WH9 003-1VA00</b></p>	<p>50 units</p>
 <p>8WH9 070-0BA00</p> <p><b>Compartment partitions, for terminal size 1.5 ... 4 mm<sup>2</sup></b></p> <ul style="list-style-type: none"> <li>For visual and electrical separation of terminal groups</li> <li>2 mm thick</li> <li>Gray</li> </ul>	<p><b>8WH9 070-0BA00</b></p>	<p>50 units</p>

Note:

For general accessories for 8WH terminal blocks, see chapter 8.

\* You can order this quantity or a multiple thereof.



3/2	<b>Introduction</b>
3/4	<b>8WH through-type terminals</b>
3/6	<b>8WH through-type screw terminals</b>
3/8	<b>8WH N-conductor isolating terminals</b>
3/10	<b>8WH N-conductor isolating screw terminals</b>
3/12	<b>8WH installation terminals</b>

## More technical product information:

Service&Support Portal:  
[www.support.automation.siemens.com](http://www.support.automation.siemens.com)

Product List:  
Technical specifications





Entry List:  
Updates / Downloads / FAQ /  
Manuals / Operating instructions /  
Characteristic curves / Certificates

# 8WH6 iPo Installation Terminals

## Introduction

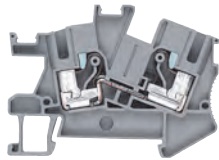
3

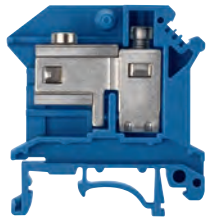
### Overview

	Devices	Page	Function
	8WH through-type terminals	3/4	Connection of incoming and outgoing conductors up to 6 mm <sup>2</sup>
	8WH through-type screw terminals	3/6	Connection of incoming and outgoing conductors up to 35 mm <sup>2</sup> with screw terminals
	8WH N-conductor isolating terminals	3/8	Terminal blocks up to 6 mm <sup>2</sup> and connection of an N-busbar 10 mm × 3 mm
	8WH N-conductor isolating screw terminals	3/10	Terminal blocks with screw connection up to 35 mm <sup>2</sup> and connection of an N-busbar 10 mm × 3 mm
	8WH installation terminals	3/12	Terminal blocks for connection of an N-busbar 10 mm × 3 mm. These terminals offer up to three terminal functions in a single enclosure and are optimized for distribution board applications in installation technology.

Conductor cross-section	Terminal type <sup>1)</sup>	Terminal type → Design → No. of clamping points → Order No. (digits 1 ... 7) →	Terminal type →	iPo technology	Screw terminals	iPo technology	Order No.
			Color	Standard	Standard	Insta	(digits 8 ... 12)
				8WH6 000	2 8WH1 001	8WH6 001	
2.5 mm <sup>2</sup>	Through-type	Gray	✓	--	--	0AF00	
		Blue	✓	--	--	0AF01	
	N-conductor isolating	Blue	✓	--	--	0BF00	
	PE	Green/yellow	✓	--	--	0CF07	
	Insta	L	Gray	--	--	✓	4QF00
		L/L		--	--	✓	4DF00
		L/N		--	--	✓	4CF00
		PE/L/L		--	--	✓	4HF00
		PE/L/N		--	--	✓	4EF00
		PE/L/NT		--	--	✓	4FF00
PE/L/N isolating blade			--	--	✓	4GF00	
PE/L/L isolating blade			--	--	✓	4NF00	
4 mm <sup>2</sup>	Through-type	Gray	✓	--	--	0AG00	
		Blue	✓	--	--	0AG01	
	N-conductor isolating	Gray	✓	--	--	0BG00	
	PE	Green/yellow	✓	--	--	0CG07	
6 mm <sup>2</sup>	Through-type	Gray	✓	--	--	0AH00	
		Blue	✓	--	--	0AH01	
	N-conductor isolating	Blue	✓	--	--	0BH00	
	PE	Green/yellow	✓	--	--	0CH07	
10 mm <sup>2</sup>	N-conductor isolating	Blue	--	✓	--	0BJ01	
16 mm <sup>2</sup>	Through-type	Blue	--	✓	--	0AK01	
		Gray	--	✓	--	0AK00	
	N-conductor isolating	Blue	--	✓	--	0BK01	
35 mm <sup>2</sup>	Through-type	Green/yellow	--	✓	--	0CK07	
		Gray	--	✓	--	0AM00	
	N-conductor isolating	Blue	--	✓	--	0AM01	
		Blue	--	✓	--	0BM01	
PE	Green/yellow	--	✓	--	0CM07		

<sup>1)</sup> Only the main terminal types are listed here. You will find further versions on the following pages.

# 8WH6 iPo Installation Terminals

## 8WH through-type terminals

3

### Overview

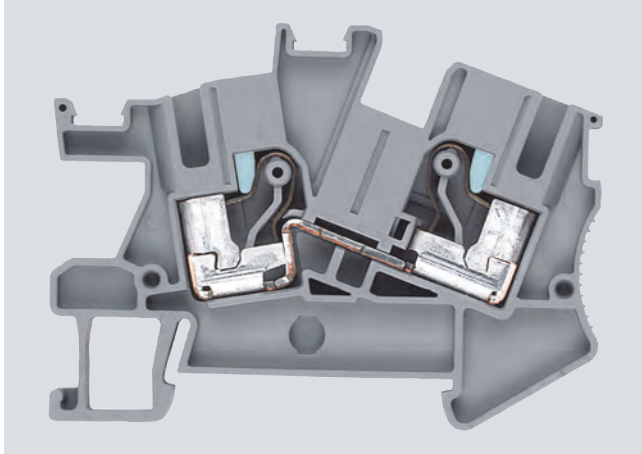

All types of conductors can be used with 8WH6 iPo technology. Rigid conductors and crimped flexible conductors are plugged directly into the terminal.

Flexible, untreated conductors can be connected using a screw-driver.

These terminals can be used interconnected with the N-busbar 10 × 3 mm.

A label can be snapped on to the middle of each terminal at the front. Labels can also be mounted flat on the clamping points of the terminals.

### Technical specifications

		8WH6 001-0AF00 8WH6 001-0AF00	8WH6 001-0CF07	8WH6 001-0AG00 8WH6 001-0AG01	8WH6 000-0CG07	8WH6 001-0AH00 8WH6 001-0AH01	8WH6 001-0AH07
Cross-section	mm <sup>2</sup>	2.5	2.5 (PE)	4	4 (PE)	6	6 (PE)
Dimensions							
• Width/length/width of cover	mm	5.2 / 59.5 / 2.2		6.2 / 66 / 2.2		8.2 / 66 / 2.2	
• Height (TS 35/7.5 / TS 35/15)	mm	43 / 50.5		46.3 / 53.8		50 / 57.5	
Rated current $I_n$ / cross-section	A / mm <sup>2</sup>	24 / 2.5		32 / 4		41 / 6	
Max. load current $I_{max}$ / cross-section	A / mm <sup>2</sup>	24 / 4		32 / 6		50 / 10	
Rated voltage $U_n$	V	800		800		800	
Connection capacities							
• Rigid	mm <sup>2</sup>	0.14 ... 4		0.2 ... 6		0.5 ... 10	
• Flexible with end sleeve	mm <sup>2</sup>	0.25 ... 2.5		0.25 ... 4		0.5 ... 6	
Stripped length	mm	10		12		12	
Molded plastic type		PA					
Flammability class acc. to UL 94		V0					
Support rails/protective conductor busbars		--		See section "Support rails" on page 1/3		See section "Support rails" on page 1/3	

### Selection and ordering data

Version	DT	Order No.	Price per PU	PU (UNIT, SET, M)	PS* / P. unit	PG
---------	----	-----------	--------------	-------------------	---------------	----

#### Terminal size 2.5 mm<sup>2</sup>

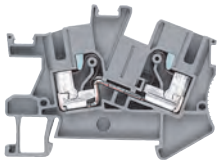

8WH6 001-0AF00

#### Through-type terminals, terminal size 2.5 mm<sup>2</sup>, acc. to IEC 60 947-7-1

- Terminal width 5.2 mm, terminal length 59.5 mm
- Terminal height (NS 35/7.5) 43 mm
- Max. load current  $I_{max} = 24$  A
- Rated voltage  $U_n = 800$  V
- Rigid 0.14 ... 4 mm<sup>2</sup>
- Flexible with end sleeve 0.14 ... 2.5 mm<sup>2</sup>
- AWG 26-12

#### Versions

- Gray
- Blue

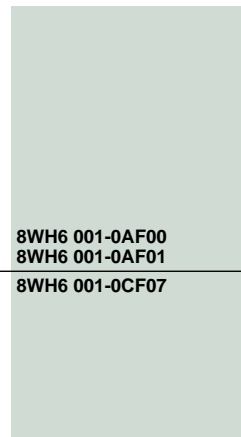

8WH6 001-0AF00

8WH6 001-0AF01

8WH6 001-0CF07

1 50 units 044

1 50 units 044







1 50 units 044

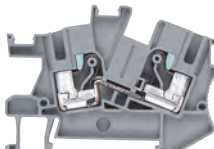

8WH6 001-0CF07

#### PE through-type terminals, terminal size 2.5 mm<sup>2</sup>, IEC 60 947-7-2

- Green/yellow
- Terminal width 5.2 mm, terminal length 59.5 mm
- Terminal height 43 mm
- Cross-section max. 4 mm<sup>2</sup>
- Rigid 0.2 ... 4 mm<sup>2</sup>
- Flexible with end sleeve 0.2 ... 2.5 mm<sup>2</sup>
- AWG 24-12

Version	DT	Order No.	Price per PU	PU (UNIT, SET, M)	PS*/P. unit	PG
<b>Terminal size 4 mm<sup>2</sup></b>						
 8WH6 001-0AG00		<b>Through-type terminals, terminal size 4 mm<sup>2</sup>, acc. to IEC 60947-7-1</b> <ul style="list-style-type: none"> <li>Terminal width 6.2 mm</li> <li>Terminal length 66 mm</li> <li>Terminal height 46.3 mm</li> <li>Max. load current <math>I_{max} = 32</math> A</li> <li>Rated voltage <math>U_n = 800</math> V</li> <li>Rigid 0.2 ... 6 mm<sup>2</sup></li> <li>Flexible with end sleeve 0.2 ... 4 mm<sup>2</sup></li> <li>AWG 24-10</li> </ul>				
Versions						
<ul style="list-style-type: none"> <li>Gray</li> <li>Blue</li> </ul>		<b>8WH6 001-0AG00</b> <b>8WH6 001-0AG01</b>		1 50 units 1 50 units	044 044	
 8WH6 001-0AG07		<b>PE through-type terminals, terminal size 4 mm<sup>2</sup>, acc. to IEC 60947-7-2</b> <ul style="list-style-type: none"> <li>Green/yellow</li> <li>Terminal width 6.2 mm</li> <li>Terminal length 66 mm</li> <li>Terminal height 46.3 mm</li> <li>Rigid 0.2 ... 6 mm<sup>2</sup></li> <li>Flexible with end sleeve 0.2 ... 4 mm<sup>2</sup></li> <li>AWG 24-10</li> </ul>				
		<b>8WH6 001-0CG07</b>		1 50 units	044	
<b>Terminal size 6 mm<sup>2</sup></b>						
 8WH6 001-0AH00		<b>Through-type terminals, terminal size 6 mm<sup>2</sup>, acc. to IEC 60947-7-1</b> <ul style="list-style-type: none"> <li>Terminal width 8.2 mm</li> <li>Terminal length 66 mm</li> <li>Terminal height 50 mm</li> <li>Max. load current <math>I_{max} = 41</math> A</li> <li>Rated voltage <math>U_n = 800</math> V</li> <li>Rigid 0.5 ... 10 mm<sup>2</sup></li> <li>Flexible with end sleeve 0.5 ... 6 mm<sup>2</sup></li> <li>AWG 20 ... 8</li> </ul>				
Versions						
<ul style="list-style-type: none"> <li>Gray</li> <li>Blue</li> </ul>		<b>8WH6 001-0AH00</b> <b>8WH6 001-0AH01</b>		1 50 units 1 50 units	044 044	
 8WH6 001-0AH01		<b>PE through-type terminals, terminal size 6 mm<sup>2</sup>, acc. to IEC 60947-7-2</b> <ul style="list-style-type: none"> <li>Green/yellow</li> <li>Terminal width 8.2 mm</li> <li>Terminal length 66 mm</li> <li>Terminal height 50 mm</li> <li>Rigid 0.5 ... 10 mm<sup>2</sup></li> <li>Flexible without end sleeve 0.5 ... 10 mm<sup>2</sup></li> <li>Flexible with end sleeve 0.5 ... 6 mm<sup>2</sup></li> <li>AWG 20-8</li> </ul>				
		<b>8WH6 001-0CH07</b>		1 50 units	044	
<b>Accessories</b>						
 8WH9 143-0AF01		<b>Support brackets</b> <ul style="list-style-type: none"> <li>Made of blue molded plastic</li> <li>For holding the N-busbar</li> </ul>				
Versions						
<ul style="list-style-type: none"> <li>For terminal size 2.5 ... 4 mm<sup>2</sup></li> <li>For terminal size 6 mm<sup>2</sup></li> </ul>		<b>8WH9 143-0AF01</b> <b>8WH9 143-0AH01</b>		1 50 units 1 50 units	044 044	
 8WH9 000-1WA00		<b>Covers</b> Gray				
Versions						
<ul style="list-style-type: none"> <li>For terminal size 2.5 mm<sup>2</sup></li> <li>For terminal size 4 mm<sup>2</sup></li> <li>For terminal size 6 mm<sup>2</sup></li> </ul>		<b>8WH9 000-1WA00</b> <b>8WH9 003-7WA00</b> <b>8WH9 004-1WA00</b>		100 50 units 100 50 units 100 50 units	044 044 044	

Note:

For general accessories for 8WH terminal blocks, [see chapter 8](#).

# 8WH6 iPo Installation Terminals

## 8WH through-type screw terminals

3

### Overview

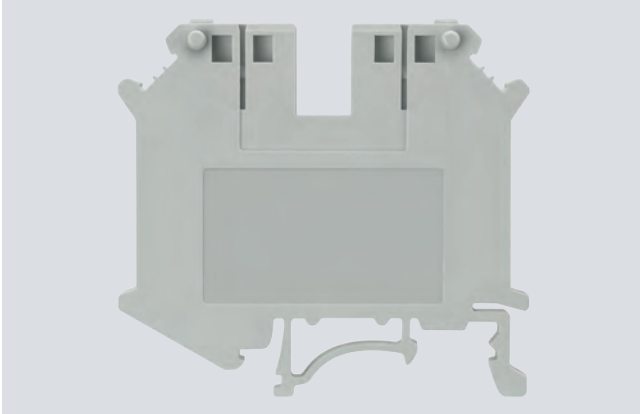

We offer a comprehensive range of installation terminals with iPo technology for use in building management systems. We also offer a range of compact, cost-effective terminal blocks with screw terminals for connecting larger cross-sections.

Terminal blocks mounted on N-busbars are most commonly used in building management systems. In order to enable the butt-mounting of different terminals, contact to the N-busbar is always on the same mounting level. This means that 8WH1-001 screw terminals and 8WH6-001 plug-in terminals can be combined as required and mounted on a single support rail.

Labels can be affixed at each clamping point by simply snapping them on at the front.

### Technical specifications

		8WH1 001-0AK00 8WH1 001-0AK01	8WH1 001-0CK07	8WH1 001-0AM00 8WH1 001-0AM01	8WH1 001-0CM07
Cross-section	mm <sup>2</sup>	16	16 (PE)	35	35 (PE)
Max. cross-section with comb (rigid/flexible)	mm <sup>2</sup>	16 / 16	--	35 / 35	--
Dimensions					
• Width/length/width of cover	mm	12.2 / 42.5 / 1.8	12.2 / 42.5 / --	15.2 / 55 / --	15.2 / 55 / --
• Height (TS 35/7.5 / TS 35/15)	mm	47 / 54.5 / 52	47 / 54.5 / 52	51 / 58.5 / 56	51 / 58.5 / 56
Max. load current $I_{max}$ / cross-section	A / mm <sup>2</sup>	101 / 25	101 / 25	125 / 35	125 / 35
Rated impulse withstand voltage/pollution degree	kV	6 / 3	6 / 3	8 / 3	8 / 3
Overvoltage category / molded plastic group		III / I	III / I	III / I	III / I
Connection capacities					
• For one conductor					
- Rigid	mm <sup>2</sup>	1.5 ... 16	1.5 ... 16	0.75 ... 35	0.75 ... 35
- Flexible with end sleeve	mm <sup>2</sup>	1.5 ... 16	1.5 ... 16	0.75 ... 35	0.75 ... 35
• For two conductors of same cross-section					
- Rigid / flexible	mm <sup>2</sup>	1.5 ... 6 / 1.5 ... 6	1.5 ... 6 / 1.5 ... 4	0.75 ... 15 / 0.75 ... 10	0.75 ... 16 / 0.75 ... 10
- Flexible with end sleeve	mm <sup>2</sup>	1.5 ... 4	1.5 ... 6	0.75 ... 10	0.75 ... 10
Stripped length	mm	11	11	16	16
Plug gauge (IEC 60947-1)		B7	B7	B9	B9
Clamping point: Screw thread / tightening torque	Nm	M4 / 1.5 ... 1.8	M4 / 1.5 ... 1.8	M6 / 3.2 ... 3.7	M5 / 3.2 ... 3.7
Fixing: Screw thread / tightening torque	Nm	--	M4 / 1.5 ... 1.8	--	M5 / 2.5 ... 3
Molded plastic type		PA	PA	PA	PA
Flammability class acc. to UL 94		V2	V2	V2	V2
Approval data (UL/cUL and CSA)					
• UL/cUL					
- Rated voltage / rated current / conductor sizes	V/A/AWG	600 / 85 / 22-4	-- / -- / 22-4	600 / 115 / 18-2	-- / -- / 18-2
• CSA					
- Rated voltage / rated current / conductor sizes	V/A/AWG	600 / 85 / 22-4	-- / -- / 22-4	600 / 130 / 18-2	-- / -- / --

### Selection and ordering data

Version	Order No.	MOQ*
---------	-----------	------

#### Terminal size 16 mm<sup>2</sup>



8WH1 001-0AK00

#### Through-type screw terminals, terminal size 16 mm<sup>2</sup>







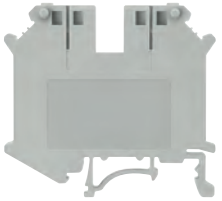

Width 12.2 mm

#### Versions

- Gray
- Blue

8WH1 001-0AK00  
8WH1 001-0AK01

50 units  
50 units

Version	Order No.	MOQ*
<b>Terminal size 16 mm<sup>2</sup> (contd.)</b>		
 <p><b>Through-type screw PE terminals, terminal size 16 mm<sup>2</sup></b></p> <ul style="list-style-type: none"> <li>• Width 12.2 mm</li> <li>• Enclosed at both ends</li> <li>• Green/yellow</li> </ul> <p>8WH1 001-0CK07</p>	<b>8WH1 001-0CK07</b>	50 units
<b>Terminal size 35 mm<sup>2</sup></b>		
 <p><b>Through-type screw terminals, terminal size 35 mm<sup>2</sup></b></p> <ul style="list-style-type: none"> <li>• Width 16 mm</li> <li>• Enclosed at both ends</li> </ul> <p>Versions</p> <ul style="list-style-type: none"> <li>• Gray</li> <li>• Blue</li> </ul> <p>8WH1 001-0AM00</p>	<b>8WH1 001-0AM00</b> <b>8WH1 001-0AM01</b>	50 units 50 units
 <p><b>Through-type screw PE terminals, terminal size 35 mm<sup>2</sup></b></p> <ul style="list-style-type: none"> <li>• Width 16 mm</li> <li>• Enclosed at both ends</li> <li>• Green/yellow</li> </ul> <p>8WH1 001-0CM07</p>	<b>8WH1 001-0CM07</b>	50 units
<b>Accessories</b>		
 <p><b>Covers, for screw terminals</b></p> <ul style="list-style-type: none"> <li>• 10/16 mm<sup>2</sup></li> <li>• Width 2 mm</li> <li>• Gray</li> </ul> <p>8WH9 005-3PA00</p>	<b>8WH9 005-3PA00</b>	50 units
 <p><b>Bridge, 10-pole</b></p> <p>For through-type terminals, 16 mm<sup>2</sup>, gray and blue</p> <p>8WH9 030-6AL00</p>	<b>8WH9 030-6AL00</b>	10 units
 <p><b>Bridge, 2-pole</b></p> <p>For through-type terminals, 35 mm<sup>2</sup>, gray and blue</p> <p>8WH9 030-6BC00</p>	<b>8WH9 030-6BC00</b>	10 units
 <p><b>Bridge, 3-pole</b></p> <p>For through-type terminals, 35 mm<sup>2</sup>, gray and blue</p> <p>8WH9 030-6BD00</p>	<b>8WH9 030-6BD00</b>	10 units
 <p><b>Compartment partitions</b></p> <p>For through-type terminals, 16 mm<sup>2</sup>, gray and blue</p> <p>8WH9 070-6HA00</p>	<b>8WH9 070-6HA00</b>	50 units
 <p><b>Insulation plates</b></p> <p>For through-type terminals, 16 and 35 mm<sup>2</sup>, gray and blue</p> <p>8WH9 070-6GA00</p>	<b>8WH9 070-6GA00</b>	50 units

Note:

For general accessories for 8WH terminal blocks, [see chapter 8](#).

\* You can order this quantity or a multiple thereof.

# 8WH6 iPo Installation Terminals

## 8WH N-conductor isolating terminals

3

### Overview

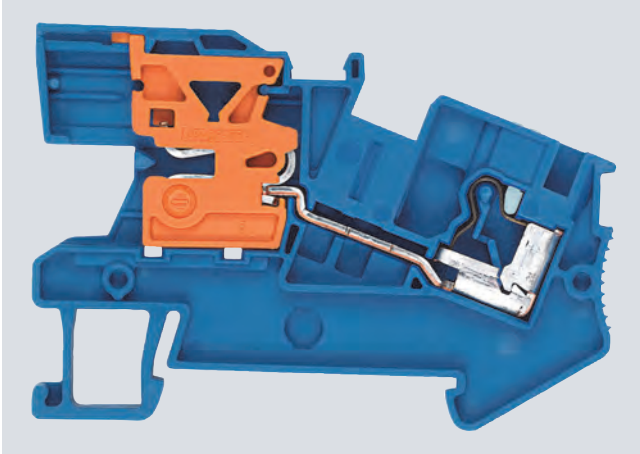

The N-conductor disconnect slides are in the same position on all 8WH6-001 terminals using iPo plug-in technology.

A 10 mm × 3 mm busbar is used.

**Notice:** Only use Cu busbars.







Installation instructions: To ensure that the N-busbars are securely mounted, the support brackets must be placed at the beginning and end of each terminal strip (in the case of longer terminal strips: every 20 cm).

A label can be snapped on to the middle of the terminal at the front. Labels can also be mounted flat on the clamping points of the terminals (not with N-busbar connection).

### Technical specifications

		8WH6 001-0BF01	8WH6 001-0BG01	8WH6 001-0BH01
Cross-section	mm <sup>2</sup>	2.5	4	6
Dimensions				
• Width/length/width of cover	mm	5.2 / 59 / 2.2	6.2 / 66 / 2.2	8.2 / 66 / 2.2
• Height (NS 35/7.5 / NS 35/15)	mm	46.3 / 53.8	46.3 / 53.8	50 / 57.5
Rated current $I_n$ / cross-section	A / mm <sup>2</sup>	24 / 2.5	32 / 4	41 / 6
Rated voltage $U_n$	V	250	250	400
Connection capacities				
• Rigid	mm <sup>2</sup>	0.14 ... 4	0.2 ... 6	0.5 ... 10
• Flexible with end sleeve	mm <sup>2</sup>	0.25 ... 2.5	0.25 ... 4	0.5 ... 6
Stripped length	mm	10	10	12
Molded plastic type		PA	PA	PA
• Flammability class acc. to UL 94		V0	V0	V0

### Selection and ordering data

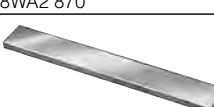
	Version	Order No.	MOQ*
<b>Terminal size 2.5 mm<sup>2</sup></b>			
	<p><b>N-conductor isolating terminals, terminal size 2.5 mm<sup>2</sup>, acc. to IEC 60947-7-1</b></p> <ul style="list-style-type: none"> <li>• Two clamping points</li> <li>• Terminal width 5.2 mm</li> <li>• Terminal length 59 mm</li> <li>• Terminal height (NS 35/7.5) 46.3 mm</li> <li>• Rated current 24 A / cross-section 2.5 mm<sup>2</sup></li> <li>• Rated voltage <math>U_n = 250</math> V</li> <li>• Rigid 0.14 ... 4 mm<sup>2</sup></li> <li>• Flexible with end sleeve 0.14 ... 2.5 mm<sup>2</sup></li> <li>• AWG 26 to 12</li> </ul>	<b>8WH6 001-0BF01</b>	50 units
8WH6 001-0BF01			
<b>Terminal size 4 mm<sup>2</sup></b>			
	<p><b>N-conductor isolating terminals, terminal size 4 mm<sup>2</sup>, acc. to IEC 60947-7-1</b></p> <ul style="list-style-type: none"> <li>• Two clamping points</li> <li>• Terminal width 6.2 mm</li> <li>• Terminal length 66 mm</li> <li>• Terminal height (NS 35/7.5) 46.3 mm</li> <li>• Rated current 32 A / cross-section 4 mm<sup>2</sup></li> <li>• Rated voltage <math>U_n = 250</math> V</li> <li>• Rigid 0.2 ... 6 mm<sup>2</sup></li> <li>• Flexible with end sleeve 0.25 ... 4 mm<sup>2</sup></li> <li>• AWG 24 to 10</li> </ul>	<b>8WH6 001-0BG01</b>	50 units
8WH6 001-0BG01			
<b>Terminal size 6 mm<sup>2</sup></b>			
	<p><b>N-conductor isolating terminals, terminal size 6 mm<sup>2</sup>, acc. to IEC 60947-7-1</b></p> <ul style="list-style-type: none"> <li>• Two clamping points</li> <li>• Terminal width 8.2 mm</li> <li>• Terminal length 66.3 mm</li> <li>• Terminal height (NS 35/7.5) 50 mm</li> <li>• Max. load current <math>I_{max} = 41</math> A</li> <li>• Rated current 41 A / cross-section 6 mm<sup>2</sup></li> <li>• Rated voltage <math>U_n = 400</math> V</li> <li>• Rigid 0.5 ... 10 mm<sup>2</sup></li> <li>• Flexible with end sleeve 0.5 ... 6 mm<sup>2</sup></li> <li>• AWG 20-8</li> </ul>	<b>8WH6 001-0BH01</b>	50 units
8WH6 001-0BH01			
<b>Accessories</b>			
	<p><b>Support brackets</b></p> <ul style="list-style-type: none"> <li>• Made of blue molded plastic</li> <li>• For holding the N-busbar</li> </ul> <p>Versions</p> <ul style="list-style-type: none"> <li>• For terminal size 2.5 ... 4 mm<sup>2</sup></li> <li>• For terminal size 6 mm<sup>2</sup></li> </ul>	<b>8WH9 143-0AF01</b> <b>8WH9 143-0AH01</b>	50 units 50 units
8WH9 143-0AF01			
	<p><b>Covers</b></p> <p>Gray</p> <p>Versions</p> <ul style="list-style-type: none"> <li>• For terminal size 2.5 mm<sup>2</sup></li> <li>• For terminal size 4 mm<sup>2</sup></li> <li>• For terminal size 6 mm<sup>2</sup></li> </ul>	<b>8WH9 000-1SA00</b> <b>8WH9 003-1SA00</b> <b>8WH9 004-1SA00</b>	50 units 50 units 1 unit
8WH9 000-1SA00			
	<p><b>Feeder terminals, for N-busbars</b></p> <ul style="list-style-type: none"> <li>• 6 × 6 mm and 10 × 3 mm</li> <li>• Bare</li> </ul> <p>Versions</p> <ul style="list-style-type: none"> <li>• Rated uninterrupted current 32 A, for connection of up to 4 mm<sup>2</sup></li> <li>• Rated uninterrupted current 76 A, for connection of up to 25 mm<sup>2</sup></li> <li>• Rated uninterrupted current 125 A, for connection of up to 35 mm<sup>2</sup></li> </ul>	<b>8WA2 867</b> <b>8WA2 868</b> <b>8WA2 870</b>	50 units 50 units 50 units
8WA2 867/8WA2 868/ 8WA2 870			
	<p><b>N-busbars, 10 mm × 3 mm</b></p> <ul style="list-style-type: none"> <li>• Tin-plated</li> <li>• 1000 mm long</li> </ul>	<b>8WA2 842</b>	1 unit
8WA2 842			

Note:

For general accessories for 8WH terminal blocks, see chapter 8.

\* You can order this quantity or a multiple thereof.

# 8WH6 iPo Installation Terminals

## 8WH N-conductor isolating screw terminals

3

### Overview

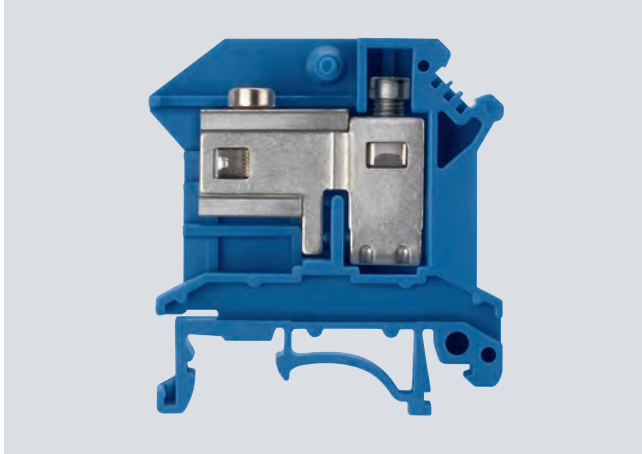

We offer a comprehensive range of installation terminals with iPo plug-in technology for use in building management systems. We also offer a range of compact, cost-effective terminal blocks with screw terminals for connecting larger cross-sections.

Terminal blocks mounted on N-busbars are most commonly used in building management systems. In order to enable the butt-mounting of different terminals, contact to the N-busbar is always on the same mounting level. This means that 8WH1-001 screw terminals and 8WH6-001 plug-in terminals can be combined as required and mounted on a single support rail.

The compact design of our N-conductor isolating terminals makes for a neat and clearly arranged terminal strip. The N-busbar can be connected over the terminal or over the disconnect slide of the N-conductor isolating terminal. The N-conductor isolating terminal also makes it easy to perform insulation measurements.







Labels can be affixed on the clamping points (screw) by simply snapping them on at the front.

**Notice: Only use Cu busbars.**

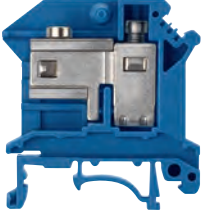
### Technical specifications

		8WH1 001-0BJ01	8WH1 001-0BK01	8WH1 001-0BM01
Cross-section	mm <sup>2</sup>	10	16	35
Dimensions				
• Width/length/width of cover	mm	10.2 / 43.5 / 1.8	12.2 / 43.5 / 1.5	16 / 55 / --
• Height (TS 35/7.5 / TS 35/15)	mm	47 / 54.5 / 52	54 / 61.5 / 59	51 / 58.5 / 56
Max. load current $I_{max}$ / cross-section	A / mm <sup>2</sup>	63 / 16	90 / 25	110 / 35
Rated impulse withstand voltage/pollution degree	kV	6 / 3	6 / 3	6 / 3
Overvoltage category / molded plastic group		III / I	III / I	III / I
Connection capacities				
• For one conductor				
- Rigid	mm <sup>2</sup>	0.5 ... 10	1.5 ... 16	0.75 ... 35
- Flexible with end sleeve	mm <sup>2</sup>	0.5 ... 6	1.5 ... 16	0.75 ... 35
• For two conductors of same cross-section				
- Rigid / flexible	mm <sup>2</sup>	0.5 ... 4 / 0.5 ... 4	1.5 ... 6 / 1.5 ... 4	0.75 ... 16 / 0.75 ... 10
- Flexible with end sleeve	mm <sup>2</sup>	0.5 ... 2.5	1.5 ... 8	0.75 ... 10
Stripped length	mm	12	11	16
Plug gauge (IEC 60947-1)		B5	B6	B9
Clamping point: Screw thread / tightening torque	Nm	M4 / 1.5 ... 1.8	M4 / 1.5 ... 1.8	M6 / 3.2 ... 3.7
Fixing: Screw thread / tightening torque	Nm	M3 / 0.6 ... 0.8	M3 / 0.6 ... 0.8	M5 / 2.5 ... 3
Molded plastic type		PA	PA	PA
Flammability class acc. to UL 94		V2	V2	V2

### Selection and ordering data

Version	Order No.	MOQ*
<b>Terminal size 10 mm<sup>2</sup></b>		
 <p><b>N-conductor isolating screw terminals, terminal size 10 mm<sup>2</sup></b></p> <ul style="list-style-type: none"> <li>• Width 10 mm</li> <li>• Blue</li> </ul> <p>8WH1 001-0BJ01</p>	<b>8WH1 001-0BJ01</b>	50 units
<b>Terminal size 16 mm<sup>2</sup></b>		
 <p><b>N-conductor isolating screw terminals, terminal size 16 mm<sup>2</sup></b></p> <ul style="list-style-type: none"> <li>• Width 12 mm</li> <li>• Blue</li> </ul> <p>8WH1 001-0BK01</p>	<b>8WH1 001-0BK01</b>	50 units
<b>Terminal size 35 mm<sup>2</sup></b>		
 <p><b>N-conductor isolating screw terminals, terminal size 35 mm<sup>2</sup></b></p> <ul style="list-style-type: none"> <li>• Width 16 mm</li> <li>• Enclosed at both ends</li> <li>• Blue</li> </ul> <p>8WH1 001-0BM01</p>	<b>8WH1 001-0BM01</b>	50 units
<b>Accessories</b>		
 <p><b>Covers, for screw terminals</b></p> <ul style="list-style-type: none"> <li>• 10/16 mm<sup>2</sup></li> <li>• Width 2 mm</li> <li>• Gray</li> </ul> <p>8WH9 005-3PA00</p>	<b>8WH9 005-3PA00</b>	50 units
 <p><b>Support brackets for N-conductor isolating screw terminals, terminal size 10 ... 35 mm<sup>2</sup></b></p> <ul style="list-style-type: none"> <li>• For holding the N-busbar</li> <li>• To be placed every 20 cm</li> <li>• 2 mm wide</li> </ul> <p>8WH9 141-0BA01</p>	<b>8WH9 141-0BA01</b>	50 units
 <p><b>Terminals</b> Blue</p> <p>Versions</p> <ul style="list-style-type: none"> <li>• To 16 mm<sup>2</sup>, width: 10.3 mm</li> <li>• To 35 mm<sup>2</sup>, width: 14.4 mm, enclosed at both ends</li> </ul> <p>8WH9 126-0BA01</p>	<b>8WH9 126-0BA01</b> <b>8WH9 127-0BA01</b>	50 units 50 units
 <p><b>N-busbars, 10 mm × 3 mm</b></p> <ul style="list-style-type: none"> <li>• Made of copper, tin-plated</li> <li>• 1000 mm long</li> </ul> <p>8WA2 842</p>	<b>8WA2 842</b>	1 unit

8WA2 842

Note:

For general accessories for 8WH terminal blocks, [see chapter 8](#).

\* You can order this quantity or a multiple thereof.

# 8WH6 iPo Installation Terminals

## 8WH installation terminals

3

### Overview

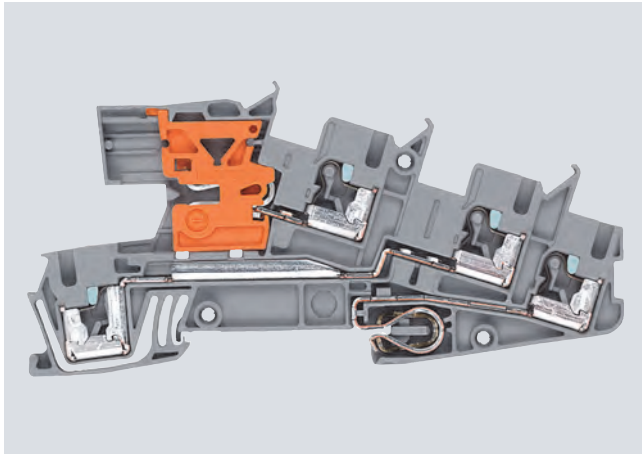

The three-tier plug-in terminals offer optimum operating characteristics for modern building installations. The plug-in connection allows tool-free wiring of the solid conductors.

These terminals can be used interconnected with the N-busbar 10 × 3 mm.

**Notice:** Only use Cu busbars.

Thanks to their compact design, the three-tier terminals can be installed in all types of building distribution boards. A load circuit can be quickly and easily wired, for example using a 5.2 mm wide installation terminal with terminal size 2.5 mm<sup>2</sup> and PE/L/NT connections.

The double bridge shafts support a multitude of individual wiring tasks. This also means it is practical and convenient to make subsequent modifications to the installation.





Labels can be mounted flat on the clamping points of the terminals.

### Technical specifications

Installation terminals, standard version	8WH6 001-4QF00 8WH6 001-4DF00 8WH6 001-4CF00	8WH6 001-0HF00 8WH6 001-4EF00	8WH6 001-4FF00
Installation terminals with isolating function		8WH6 001-4GF00 8WH6 001-4NF00 8WH6 001-4PF00 8WH6 001-4MF00	
Cross-section	mm <sup>2</sup>	2.5	
Dimensions			
• Width/length/width of cover	mm	5.5 / 101 / 2.2	
• Height (TS 35/7.5 / TS 35/15)	mm	50.5 / 58	
Rated current $I_n$ cross-section	A/ mm <sup>2</sup>	24 / 4	
Max. load current $I_{max}$ /cross-section	A/ mm <sup>2</sup>	30 <sup>1)</sup> / 4	
Rated voltage $U_n$	V	400 (L-L) 250 (L-N or L-PE)	
Connection capacities			
• Rigid	mm <sup>2</sup>	0.14 ... 4	
• Flexible with end sleeve	mm <sup>2</sup>	0.14 ... 2.5	
Stripped length without insulation stop sleeve (no insulation stop sleeves should be used when using end sleeves)	mm	10	
Stripped length with insulation stop sleeve (no insulation stop sleeves should be used when using end sleeves)	mm	10	
Plug gauge (IEC 60947-1)		A3	
Molded plastic type		PA	
Flammability class acc. to UL 94		V0	

<sup>1)</sup> 3-pole terminal block

### Selection and ordering data

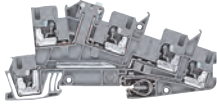
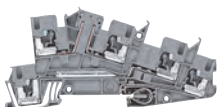



Version	Order No.	MOQ*
<b>Terminal size 2.5 mm<sup>2</sup></b>		
 8WH6 001-4QF00  8WH6 001-4DF00  8WH6 001-4HF00  8WH6 001-4FF00	<p><b>Installation terminals, terminal size 2.5 mm<sup>2</sup>, standard version for N-busbar</b></p> <ul style="list-style-type: none"> <li>• Gray</li> <li>• Terminal width 5.2 mm</li> <li>• Rigid 0.14 ... 4 mm<sup>2</sup></li> <li>• Flexible with end sleeve 0.14 ... 2.5 mm<sup>2</sup></li> <li>• AWG 26-12</li> <li>• Rated current 24 A / cross-section 4 mm<sup>2</sup></li> <li>• Rated voltage <math>U_n = 400</math> V (L-L) <math>U_n = 250</math> V (L-N or L-PE)</li> </ul> <p>Versions</p> <ul style="list-style-type: none"> <li>• L</li> <li>• L/L</li> <li>• L/N</li> <li>• PE/L/L</li> <li>• PE/L/N</li> <li>• PE/L/NT</li> </ul>	<p>50 units</p> <p>50 units</p> <p>50 units</p> <p>50 units</p> <p>50 units</p> <p>50 units</p>
 8WH6 001-4NF00	<p><b>Installation terminals, terminal size 2.5 mm<sup>2</sup>, with isolating blade</b></p> <ul style="list-style-type: none"> <li>• Gray</li> <li>• Terminal width 5.2 mm</li> <li>• Rigid 0.25 ... 4 mm<sup>2</sup></li> <li>• Flexible with end sleeve 0.25 ... 2.5 mm<sup>2</sup></li> <li>• AWG 22-12</li> <li>• Rated current 24 A / cross-section 4 mm<sup>2</sup></li> <li>• Rated voltage <math>U_n = 400</math> V (L-L) <math>U_n = 250</math> V (L-N or L-PE)</li> </ul> <p>Versions</p> <ul style="list-style-type: none"> <li>• PE/L/L (standard version, suitable for isolating terminal)</li> <li>• PE/L/N isolating blade</li> <li>• PE/L/L isolating blade</li> </ul>	<p>50 units</p> <p>50 units</p> <p>50 units</p>
 8WH6 001-4PF00	<p><b>Installation terminals, terminal size 2.5 mm<sup>2</sup>, for isolating function</b></p> <ul style="list-style-type: none"> <li>• Gray</li> <li>• Terminal width 5.2 mm</li> <li>• Rigid 0.25 ... 4 mm<sup>2</sup></li> <li>• Flexible with end sleeve 0.25 ... 2.5 mm<sup>2</sup></li> <li>• AWG 22-12</li> <li>• Rated current 24 A / cross-section 4 mm<sup>2</sup></li> <li>• Rated voltage <math>U_n = 400</math> V (L-L) <math>U_n = 250</math> V (L-PE)</li> </ul> <p>Versions</p> <ul style="list-style-type: none"> <li>• PE/L/L (standard version, suitable for isolating terminal)</li> <li>• PE/L/L isolation</li> </ul>	<p>50 units</p> <p>50 units</p>

\* You can order this quantity or a multiple thereof.

# 8WH6 iPo Installation Terminals

## 8WH installation terminals

3

	Version	Order No.	MOQ*		
<b>Accessories</b>					
	<b>Support brackets, for terminal size 2.5 mm<sup>2</sup></b> <ul style="list-style-type: none"> <li>• For holding the N-busbar</li> <li>• To be placed every 20 cm</li> <li>• 2 mm wide</li> </ul>	<b>8WH9 142-0AF01</b>	50 units		
	<b>Covers, for terminal size 2.5 mm<sup>2</sup></b> gray	<b>8WH9 000-3SA00</b>	50 units		
	<b>Covers, for terminal size 2.5 mm<sup>2</sup> and isolating terminal in contour</b> gray	<b>8WH9 000-6SA00</b>	50 units		
	<b>Feeder terminals, for N-busbars</b> <ul style="list-style-type: none"> <li>• 6 × 6 mm and 10 × 3 mm</li> <li>• Bare</li> </ul> <table border="1"> <thead> <tr> <th>Versions</th> </tr> </thead> <tbody> <tr> <td> <ul style="list-style-type: none"> <li>• Rated uninterrupted current 32 A, for connection of up to 4 mm<sup>2</sup></li> <li>• Rated uninterrupted current 76 A, for connection of up to 25 mm<sup>2</sup></li> <li>• Rated uninterrupted current 125 A, for connection of up to 35 mm<sup>2</sup></li> </ul> </td> </tr> </tbody> </table>	Versions	<ul style="list-style-type: none"> <li>• Rated uninterrupted current 32 A, for connection of up to 4 mm<sup>2</sup></li> <li>• Rated uninterrupted current 76 A, for connection of up to 25 mm<sup>2</sup></li> <li>• Rated uninterrupted current 125 A, for connection of up to 35 mm<sup>2</sup></li> </ul>	<b>8WA2 867</b> <b>8WA2 868</b> <b>8WA2 870</b>	50 units 50 units 50 units
Versions					
<ul style="list-style-type: none"> <li>• Rated uninterrupted current 32 A, for connection of up to 4 mm<sup>2</sup></li> <li>• Rated uninterrupted current 76 A, for connection of up to 25 mm<sup>2</sup></li> <li>• Rated uninterrupted current 125 A, for connection of up to 35 mm<sup>2</sup></li> </ul>					
	<b>N-busbars, 10 mm × 3 mm</b> <ul style="list-style-type: none"> <li>• Made of copper, tin-plated</li> <li>• 1000 mm long</li> </ul>	<b>8WA2 842</b>	1 unit		

8WA2 867/8WA2 868/  
8WA2 870

8WA2 842

Note:

For general accessories for 8WH terminal blocks, [see chapter 8](#).

# 8WH2 Spring-Loaded Terminals

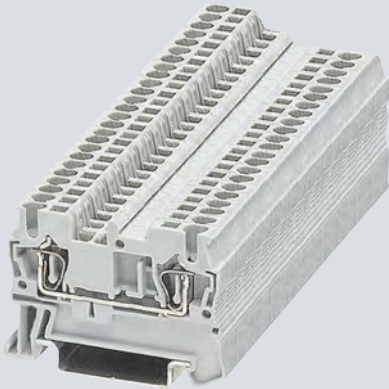

4/2	<b>Introduction</b>
4/3	<b>General data on 8WH</b>
4/7	<b>8WH through-type terminals<sup>1)</sup></b>
4/18	<b>8WH hybrid through-type terminals<sup>1)</sup></b>
4/21	<b>8WH fuse terminals</b>
4/23	<b>8WH isolating blade terminals</b>
4/25	<b>8WH isolating terminals</b>
4/27	<b>8WH two-tier terminals<sup>1)</sup></b>
4/33	<b>8WH three-tier terminals</b>
4/35	<b>8WH four-tier motor terminals</b>
4/37	<b>8WH diode terminals</b>
4/39	<b>8WH two-tier diode terminals</b>

<sup>1)</sup> Also available as a PE version

## More technical product information:

Service&Support Portal:  
[www.support.automation.siemens.com](http://www.support.automation.siemens.com)

Product List:  
Technical specifications

Entry List:  
Updates / Downloads / FAQ /  
Manuals / Operating instructions /  
Characteristic curves / Certificates

# 8WH2 Spring-Loaded Terminals

## Introduction

### Overview

4

8WH terminals	Devices	Page	Application
	Through-type terminals	4/7	Connection of incoming and outgoing conductors up to 35 mm <sup>2</sup>
	Hybrid through-type terminals	4/18	Terminals with a range of connection methods
	Fuse terminals	4/21	Terminals which can be used to protect control circuits, for example
	Isolating blade terminals	4/23	Isolation of the circuit, e.g. for test purposes
	Isolating terminals	4/25	Isolation of the circuit, e.g. for test purposes
	Two-tier terminals	4/27	Compact form of the terminal block in which two connection wires can be installed
	Three-tier terminals	4/33	Compact terminal blocks up to 2.5 mm <sup>2</sup> , in which three connection wires can be installed
	Four-tier motor terminals	4/35	Compact terminal blocks up to 4 mm <sup>2</sup> , in which three connection wires plus PE can be installed
	Diode terminals	4/37	Terminal blocks with integrated diodes
	Two-tier diode terminals	4/39	Terminal blocks with integrated diodes

### Overview

Conductor cross-section	Terminal type <sup>1)</sup>	Terminal type → Design → No. of clamping points → Order No. (digits 1 ... 7) → Color	Standard spring-loaded connection				Order No. (digits 8 ... 12)	
			Standard			Two-tier		
			2	3	4	4		
			8WH2 000	8WH2 003	8WH2 004	8WH2 020		8WH2 023
1.5 mm <sup>2</sup>	Through-type	Gray	✓	✓	✓	✓	--	0AE00
		Blue	✓	✓	✓	✓	--	0AE01
	PE	Green/yellow	✓	✓	✓	✓	--	0CE07
2.5 mm <sup>2</sup>	Through-type	Gray	✓	✓	✓	✓	✓	0AF00
		Blue	✓	✓	✓	✓	✓	0AF01
	Isolating	Gray	✓	✓	✓	--	--	6AF00
	Isolating blade	Gray	✓	✓	✓	--	--	0CF00
	PE	Green/yellow	✓	✓	✓	✓	✓	0CF07
4 mm <sup>2</sup>	Through-type	Gray	✓	✓	✓	✓	--	0AG00
		Blue	✓	✓	✓	✓	--	0AG01
	Isolating	Gray	✓	--	--	--	--	6AG00
	Isolating blade	Gray	✓	--	--	--	--	6CG00
	PE	Green/yellow	✓	✓	✓	✓	--	0CG07
6 mm <sup>2</sup>	Through-type	Gray	✓	✓	--	--	--	0AH00
		Blue	✓	✓	--	--	--	0AH01
	PE	Green/yellow	✓	✓	--	--	--	0CH07
10 mm <sup>2</sup>	Through-type	Gray	✓	--	--	--	--	0AJ00
		Blue	✓	--	--	--	--	0AJ01
	PE	Green/yellow	✓	--	--	--	--	0CJ07
16 mm <sup>2</sup>	Through-type	Gray	✓	--	--	--	--	0AK00
		Blue	✓	--	--	--	--	0AK01
	PE	Green/yellow	✓	--	--	--	--	0CK07
35 mm <sup>2</sup>	Through-type	Gray	✓	--	--	--	--	0AM00
		Blue	✓	--	--	--	--	0AM01
	PE	Green/yellow	✓	--	--	--	--	0CM07

<sup>1)</sup> Only the main terminal types are listed here. You will find further versions on the following pages.

# 8WH2 Spring-Loaded Terminals

## General data on 8WH

4

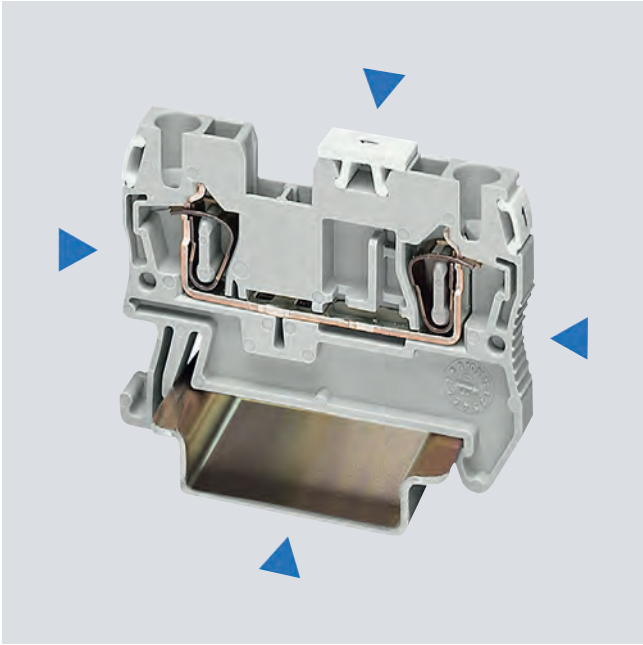

The space-saving design and conductor routing from above make spring-loaded terminals ideal for controlgear installations with minimum available space. The terminals are open at one end and can be closed using the appropriate covers.



The large and unambiguous marking in the center of the terminal is essential for ensuring reliable installation in minimum time. Each clamping point can also be separately labeled.



Spring-loaded terminals provide a large connection compartment for fast wiring of flexible and rigid conductors, including conductors with nominal cross-section and a fitted end sleeve.

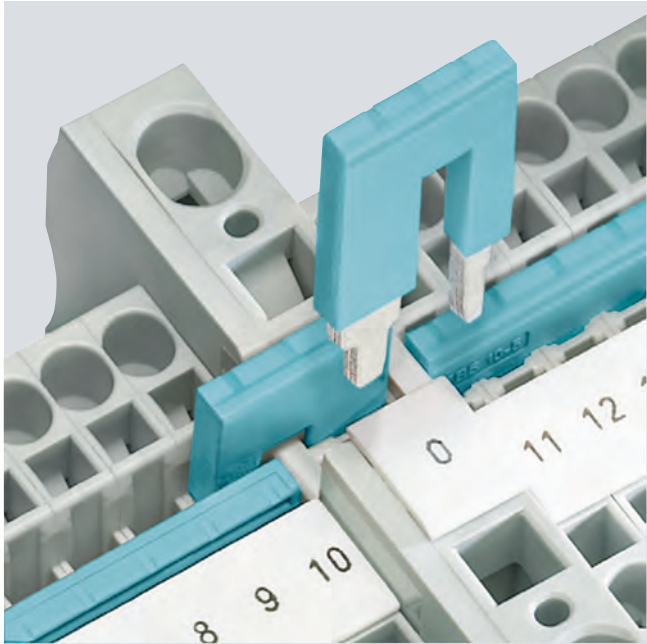

Reducing combs enable easy connection of terminals with various nominal cross-section. For example, they can be used for the fast creation of infeed blocks, e.g. by connecting a 10 mm<sup>2</sup> spring-loaded terminal with a 2.5 or 4 mm<sup>2</sup> spring-loaded terminal.

# 8WH2 Spring-Loaded Terminals

## General data on 8WH

4

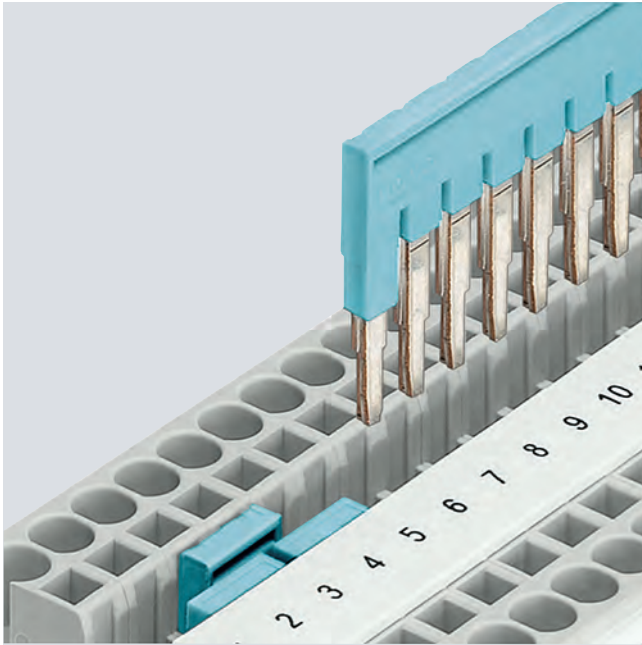

The 2 to 50-pole connecting combs also considerably reduce the time needed for assembly and wiring as they enable up to 50 terminals to be connected in a single step.

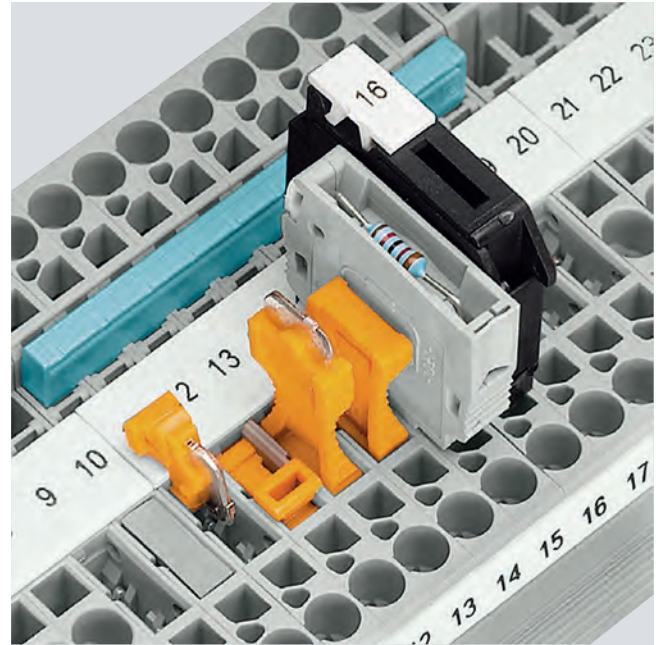

The universal plug-in zones of the isolating terminal can accommodate the isolated through-type connectors, isolating plugs, component connectors and fused connectors.

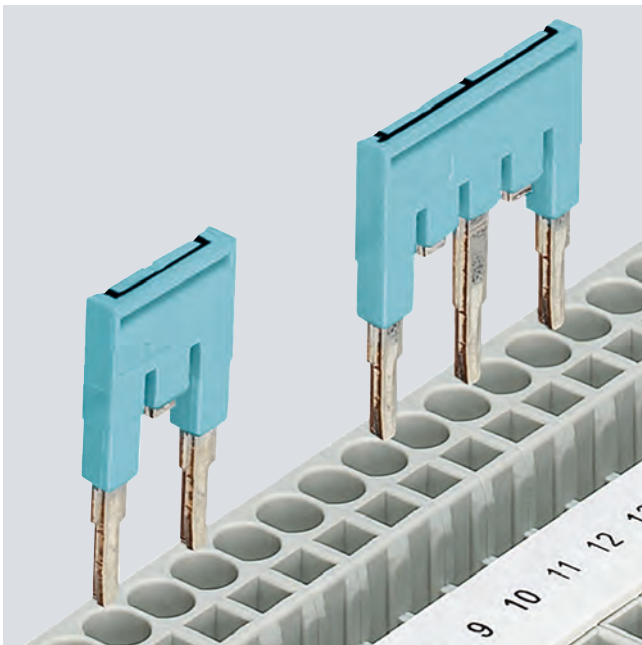

Contact tabs can be removed from the standard comb in order to skip individual terminals. This means that two potentials can run in parallel on a single terminal strip. The contact points can additionally be marked.

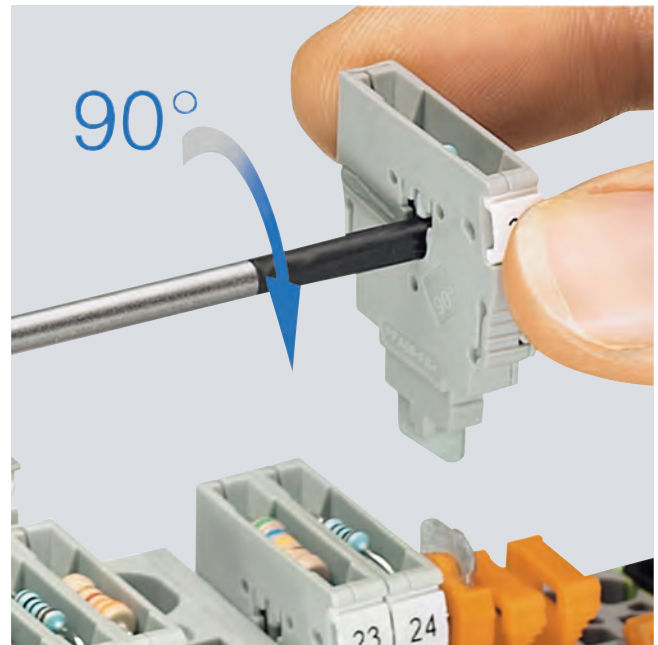

The component connector enables the convenient equipping with electronic components. One turn of the screwdriver opens the contact points and the component is easily inserted.

# 8WH2 Spring-Loaded Terminals

## General data on 8WH

4

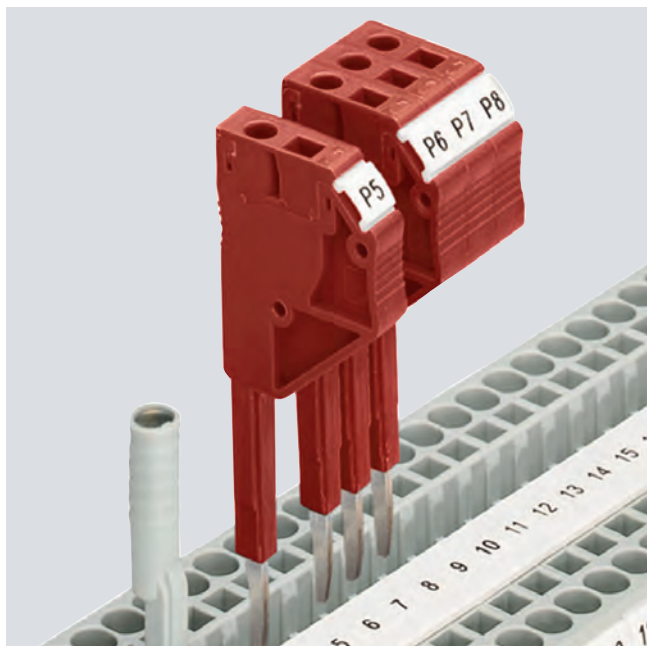

A comprehensive range of test accessories is also available for the spring-loaded terminal series. The test adapters for  $\varnothing$  4 mm test plugs and modular test plugs enable all measuring and testing jobs to be performed in minimum time.

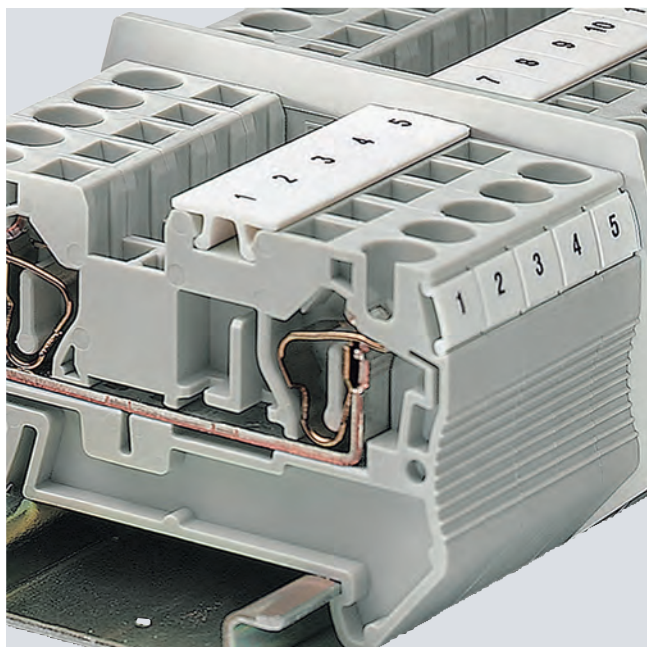

The compartment partitions project beyond the contours of the terminals and separate the groups both visually and electrically.



Cover segments are used to cover the projecting terminal segments of three and four-wire terminals when mounting two-wire terminals side-by-side. This ensures touch protection.

**Note:** The accessories for 8WH can only be used for 8WH terminals.

### Overview

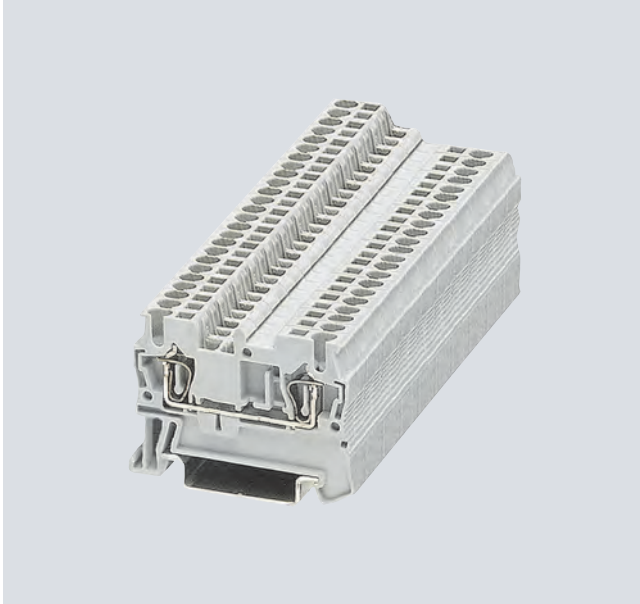

#### With two clamping points

The through-type terminals have an impressive space-saving design and offer optimized handling. With its front connection arrangement this series provides additional space between the cable ducts for wiring.

The double bridge shaft enables individual chain bridging with connecting combs. Accessories are available for testing and labeling.

#### With three clamping points

Terminals with three clamping points are a space-saving alternative to the standard through-type terminals for branching the potential.

It is often necessary for three conductors to be routed to a single terminal. This three clamping point version enables this without the need for additional terminals and jumpers.

#### With four clamping points

The double connection of the through-type terminals with four clamping points enables four conductors to be connected to a single potential. These versions with four clamping points are therefore suitable for use as compact potential distributors.

A label can be snapped on to the middle of each terminal at the front. Further labels can also be mounted flat on the side of the terminals.

#### PE/ground conductor function

The PE through-type terminals are available with the same contour as the through-type terminals. Simply snap the terminals onto the support rail to achieve full mechanical and electrical contact with the support rail.

The PE through-type terminals meet all the requirements of IEC 60947-7-2:

- Low contact resistance
- Stainless clamping points
- Green-yellow enclosure
- Additional inscription options

### Technical specifications

	8WH2 000-0AE0	8WH2 000-0CE07	8WH2 003-0AE00 8WH2 003-0AE01	8WH2 003-0CE07	8WH2 004-0AE00 8WH2 004-0AE01
Dimensions					
• Width/length/cover width in mm	4.2 / 48.5 / 2.2		4.2 / 60.5 / 2.2		4.2 / 72 / 2.2
• Height (NS 35/7.5 / NS 35/15) in mm	36.8 / 44		36.5 / 44		
Technical specifications acc. to IEC/DIN VDE					
• Max. load current in A / cross-section in mm <sup>2</sup>	17.5 / 1.5	--	17.5 / 1.5	--	17.5 / 1.5
• Rated impulse withstand voltage in kV / pollution degree	6 / 3				
• Overvoltage category / molded plastic group	III / I				
Connection capacities					
• Flexible with end sleeve, with plastic sleeve in mm <sup>2</sup>	0.25 ... 1.5				
• Flexible with end sleeve, without plastic sleeve in mm <sup>2</sup>	0.25 ... 1.5				
• Flexible with two-wire connection end sleeve, with plastic sleeve in mm <sup>2</sup>	0.5				
Stripped length in mm	10				
Plug gauge (IEC 60947-1)	A1				
Molded plastic type	PA				
• Flammability class acc. to UL 94	V0				
Approval data (UL/cUL and CSA)					
• Rated voltage / rated current / conductor sizes					
- UL/cUL: in V/A / AWG	300 / 15 / 26-14	-- / -- / 26-14	300 / 15 / 26-14	-- / -- / 26-14	300 / 15 / 26-14
- CSA: in V/A / AWG	300 / 15 / 26-14	-- / -- / 26-14	300 / 15 / 26-14	--	300 / 15 / 26-14
Support rails/protective conductor busbars	--	See section "Support rails" on page 1/3	--	See section "Support rails" on page 1/3	--

# 8WH2 Spring-Loaded Terminals

## 8WH through-type terminals

4

	8WH2 004-0CE07	8WH2 000-0AF0.	8WH2 000-0CF07	8WH2 003-0AF00 8WH2 003-0AF01	8WH2 003-0CF07
Dimensions					
• Width/length/cover width in mm	4.2 / 72 / 2.2	5.2 / 48.5 / 2.2		5.2 / 60.5 / 2.2	
• Height (NS 35/7.5 / NS 35/15) in mm	36.5 / 44	36.8 / 44		36.5 / 44	
Technical specifications acc. to IEC/DIN VDE					
• Max. load current in A / cross-section in mm <sup>2</sup>	--	31 / 4	--	28 / 4	--
• Rated impulse withstand voltage in kV / pollution degree	6 / 3	8 / 3			
• Overvoltage category / molded plastic group	III / I				
Connection capacities					
• Flexible with end sleeve, with plastic sleeve in mm <sup>2</sup>	0.25 ... 1.5	0.25 ... 2.5			
• Flexible with end sleeve, without plastic sleeve in mm <sup>2</sup>	0.25 ... 1.5	0.25 ... 2.5			
• Flexible with two-wire connection end sleeve, with plastic sleeve in mm <sup>2</sup>	0.5				
Stripped length in mm	10				
Plug gauge (IEC 60947-1)	A1	A3			
Molded plastic type	PA				
• Flammability class acc. to UL 94	V0				
Approval data (UL/cUL and CSA)					
• Rated voltage / rated current / conductor sizes	-- / -- / 26-14	300 / 20 / 26-12	-- / -- / 26-12	600 / 20 / 26-12	-- / -- / 26-12
- UL/cUL: in V/A / AWG	-- / -- / 26-14	--			
- CSA: in V/A / AWG					
Support rails/protective conductor busbars	See section "Support rails" on page 1/3	--	See section "Support rails" on page 1/3	--	See section "Support rails" on page 1/3
	8WH2 004-0AF00 8WH2 004-0AF01	8WH2 004-0CF07	8WH2 000-0AG0.	8WH2 003-0AG00 8WH2 003-0AG01	8WH2 004-0AG00 8WH2 004-0AG01
Dimensions					
• Width/length/cover width in mm	5.2 / 72 / 2.2		6.2 / 56 / 2.2	6.2 / 71.5 / 2.2	6.2 / 87 / 2.2
• Height (NS 35/7.5 / NS 35/15) in mm	36.5 / 44		36.8 / 44	36.5 / 44	
Technical specifications acc. to IEC/DIN VDE					
• Max. load current in A / cross-section in mm <sup>2</sup>	28 / 4	--	40 / 6		
• Rated impulse withstand voltage in kV / pollution degree	8 / 3				
• Overvoltage category / molded plastic group	III / I				
Connection capacities					
• Flexible with end sleeve, with plastic sleeve in mm <sup>2</sup>	0.25 ... 2.5		0.25 ... 4		
• Flexible with end sleeve, without plastic sleeve in mm <sup>2</sup>	0.25 ... 2.5		0.25 ... 4		
• Flexible with two-wire connection end sleeve, with plastic sleeve in mm <sup>2</sup>	0.5		0.5 ... 1		
Stripped length in mm	10				
Plug gauge (IEC 60947-1)	A3		A4		
Molded plastic type	PA				
• Flammability class acc. to UL 94	V0				
Approval data (UL/cUL and CSA)					
• Rated voltage / rated current / conductor sizes	600 / 20 / 26-12	-- / -- / 26-12	600 / 30 / 20-10		
- UL/cUL: in V/A / AWG	--				
- CSA: in V/A / AWG					
Support rails/protective conductor busbars	--	See section "Support rails" on page 1/3	--	--	--

# 8WH2 Spring-Loaded Terminals

## 8WH through-type terminals

4

	8WH2 000-0CG07	8WH2 003-0CG07	8WH2 004-0CG07	8WH2 000-0AH00 8WH2 000-0AH01	8WH2 003-0AH00 8WH2 003-0AH01
Dimensions					
• Width/length/cover width in mm	6.2 / 56 / 2.2	6.2 / 71.5 / 2.2	6.2 / 87 / 2.2	8.2 / 69.5 / 2.2	8.2 / 90.5 / 2.2
• Height (NS 35/7.5 / NS 35/15) in mm	36.8 / 44	36.5 / 44		43.5 / 51	
Technical specifications acc. to IEC/DIN VDE					
• Max. load current in A / cross-section in mm <sup>2</sup>	--			52 / 10	
• Rated impulse withstand voltage in kV / pollution degree	8 / 3				
• Overvoltage category / molded plastic group	III / I				
Connection capacities					
• Flexible with end sleeve, with plastic sleeve in mm <sup>2</sup>	0.25 ... 4			0.25 ... 6	
• Flexible with end sleeve, without plastic sleeve in mm <sup>2</sup>	0.25 ... 4			0.25 ... 6	
• Flexible with two-wire connection end sleeve, with plastic sleeve in mm <sup>2</sup>	0.5 ... 1			0.5 ... 1.5	
Stripped length in mm	10			12	
Plug gauge (IEC 60947-1)	A4			A5	
Molded plastic type	PA				
• Flammability class acc. to UL 94	V0				
Approval data (UL/cUL and CSA)					
• Rated voltage / rated current / conductor sizes					
- UL/cUL: in V/A / AWG	-- / -- / 20-10			600 / 50 / 20-8	
- CSA: in V/A / AWG	--				
Support rails/protective conductor busbars	See section "Support rails" on page 1/3	See section "Support rails" on page 1/3	See section "Support rails" on page 1/3	--	--

	8WH2 000-0CH07	8WH2 003-0CH07	8WH2 000-0AJ00 8WH2 000-0AJ01	8WH2 000-0CJ07
Dimensions				
• Width/length/cover width in mm	8.2 / 69.5 / 2.2	8.2 / 90.5 / 2.2	10 / 71.5 / 2.2	
• Height (NS 35/7.5 / NS 35/15) in mm	43.5 / 51		50.5 / 58	
Technical specifications acc. to IEC/DIN VDE				
• Max. load current in A / cross-section in mm <sup>2</sup>	--		65 / 16	
• Rated impulse withstand voltage in kV / pollution degree	8 / 3			
• Overvoltage category / molded plastic group	III / I			
Connection capacities				
• Flexible with end sleeve, with plastic sleeve in mm <sup>2</sup>	0.25 ... 6		0.25 ... 10	
• Flexible with end sleeve, without plastic sleeve in mm <sup>2</sup>	0.25 ... 6		0.25 ... 10	
• Flexible with two-wire connection end sleeve, with plastic sleeve in mm <sup>2</sup>	0.5 ... 1.5		1.5 ... 2.5	
Stripped length in mm	12		18	
Plug gauge (IEC 60947-1)	A5		A6	
Molded plastic type	PA			
• Flammability class acc. to UL 94	V0			
Approval data (UL/cUL and CSA)				
• Rated voltage / rated current / conductor sizes				
- UL/cUL: in V/A / AWG	-- / -- / 20-8		600 / 65 / 16-6	-- / -- / 16-6
- CSA: in V/A / AWG	--			
Support rails/protective conductor busbars	See section "Support rails" on page 1/3	See section "Support rails" on page 1/3	--	See section "Support rails" on page 1/3



	8WH2 000-0AK00 8WH2 000-0AK01	8WH2 000-0CK07	8WH2 000-0AM00 8WH2 000-0AM01	8WH2 000-0CM07
Dimensions				
• Width/length/cover width in mm	12 / 80 / 2.2		16 / 100 / --	
• Height (NS 35/7.5 / NS 35/15) in mm	51 / 58.5		59 / 66.5	
Technical specifications acc. to IEC/DIN VDE				
• Max. load current in A / cross-section in mm <sup>2</sup>	90 / 25		125 / 35	
• Rated impulse withstand voltage in kV / pollution degree	8 / 3			
• Overvoltage category / molded plastic group	III / I			
Connection capacities				
• Flexible with end sleeve, with plastic sleeve in mm <sup>2</sup>	0.25... 16		2.5 ... 35	
• Flexible with end sleeve, without plastic sleeve in mm <sup>2</sup>	0.25 ... 16		2.5 ... 35	
• Flexible with two-wire connection end sleeve, with plastic sleeve in mm <sup>2</sup>	1.5 ... 4		2.5 ... 10	
Stripped length in mm	18		25	
Plug gauge (IEC 60947-1)	A7		A8	
Molded plastic type	PA			
• Flammability class acc. to UL 94	V0			
Approval data (UL/cUL and CSA)				
• Rated voltage / rated current / conductor sizes				
- UL/cUL: in V/A / AWG	600 / 85 / 16-4	-- / -- / 16-4	600 / 115 / 14-2	-- / -- / 14-2
- CSA: in V/A / AWG	--		600 / 115 / 14-2	-- / -- / 14-2
Support rails/protective conductor busbars	--	See section "Support rails" on page 1/3	--	See section "Support rails" on page 1/3

# 8WH2 Spring-Loaded Terminals

## 8WH through-type terminals

4

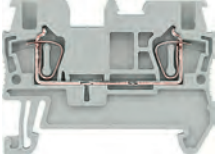
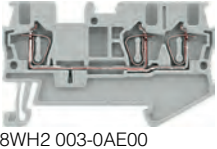
### Selection and ordering data

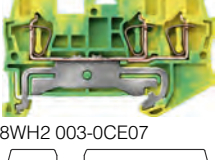
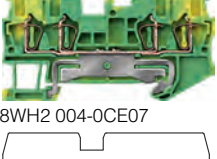
Version	Order No.	MOQ*
<b>Terminal size 1.5 mm<sup>2</sup></b>		
 <p>8WH2 000-0AE00</p>  <p>8WH2 003-0AE00</p>  <p>8WH2 004-0AE00</p>	<p><b>Through-type terminals, terminal size 1.5 mm<sup>2</sup></b></p> <ul style="list-style-type: none"> <li>Terminal width 4.2 mm</li> <li>ULus</li> <li>IEC 60947-7-1                     <ul style="list-style-type: none"> <li>Rigid 0.08 ... 1.5 mm<sup>2</sup></li> <li>Flexible 0.08 ... 1.5 mm<sup>2</sup></li> <li>AWG 28-16</li> <li>I = 17.5 A</li> <li>The total current through all connected conductors must not exceed the max. load current</li> <li>U = 500 V</li> </ul> </li> </ul> <p><b>Versions</b></p> <ul style="list-style-type: none"> <li>Two clamping points                     <ul style="list-style-type: none"> <li>Gray</li> <li>Blue</li> <li>Orange</li> <li>Red</li> <li>Black</li> <li>Green</li> <li>White</li> <li>Yellow</li> </ul> </li> <li>Three clamping points                     <ul style="list-style-type: none"> <li>Gray, Ⓢ</li> <li>Blue</li> </ul> </li> <li>Four clamping points                     <ul style="list-style-type: none"> <li>Gray, Ⓢ</li> <li>Blue</li> </ul> </li> </ul>	<p><b>8WH2 000-0AE00</b> 50 units</p> <p><b>8WH2 000-0AE01</b> 50 units</p> <p><b>8WH2 000-0AE04</b> 50 units</p> <p><b>8WH2 000-0AE02</b> 50 units</p> <p><b>8WH2 000-0AE08</b> 50 units</p> <p><b>8WH2 000-0AE03</b> 50 units</p> <p><b>8WH2 000-0AE05</b> 50 units</p> <p><b>8WH2 000-0AE06</b> 50 units</p> <hr/> <p><b>8WH2 003-0AE00</b> 50 units</p> <p><b>8WH2 003-0AE01</b> 50 units</p> <hr/> <p><b>8WH2 004-0AE00</b> 50 units</p> <p><b>8WH2 004-0AE01</b> 50 units</p>
 <p>8WH2 000-0CE07</p>  <p>8WH2 003-0CE07</p>  <p>8WH2 004-0CE07</p>	<p><b>PE through-type terminals, terminal size 1.5 mm<sup>2</sup></b></p> <ul style="list-style-type: none"> <li>Terminal width 4.2 mm</li> <li>ULus</li> <li>IEC 60947-7-1                     <ul style="list-style-type: none"> <li>Rigid 0.08 ... 1.5 mm<sup>2</sup></li> <li>Flexible 0.08 ... 1.5 mm<sup>2</sup></li> <li>AWG 28-16</li> </ul> </li> <li>Green/yellow</li> </ul> <p><b>Versions</b></p> <ul style="list-style-type: none"> <li>Two clamping points, Ⓢ</li> <li>Three clamping points</li> <li>Four clamping points, Ⓢ</li> </ul>	<p><b>8WH2 000-0CE07</b> 50 units</p> <p><b>8WH2 003-0CE07</b> 50 units</p> <p><b>8WH2 004-0CE07</b> 50 units</p>

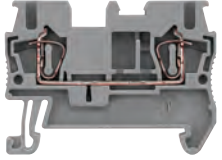
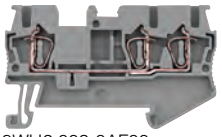
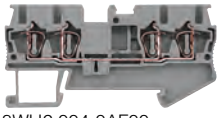

Version	Order No.	MOQ*
<b>Terminal size 2.5 mm<sup>2</sup></b>		
 <p>8WH2 000-0AF00</p> <p><b>Through-type terminals, terminal size 2.5 mm<sup>2</sup>, two clamping points</b></p> <ul style="list-style-type: none"> <li>Terminal width 5.2 mm</li> <li>CSUs</li> <li>IEC 60947-7-1                     <ul style="list-style-type: none"> <li>Rigid 0.08 ... 4 mm<sup>2</sup></li> <li>Flexible 0.08 ... 2.5 mm<sup>2</sup></li> <li>AWG 28-12</li> <li>I = 31 A</li> <li>U = 800 V</li> </ul> </li> </ul> <p><b>Versions</b></p> <ul style="list-style-type: none"> <li>Gray</li> <li>Blue</li> <li>Orange</li> <li>Red</li> <li>Black</li> <li>Green</li> <li>White</li> <li>Yellow</li> </ul>	<p><b>8WH2 000-0AF00</b></p> <p><b>8WH2 000-0AF01</b></p> <p><b>8WH2 000-0AF04</b></p> <p><b>8WH2 000-0AF02</b></p> <p><b>8WH2 000-0AF08</b></p> <p><b>8WH2 000-0AF03</b></p> <p><b>8WH2 000-0AF05</b></p> <p><b>8WH2 000-0AF06</b></p>	<p>50 units</p> <p>50 units</p> <p>50 units</p> <p>50 units</p> <p>50 units</p> <p>50 units</p> <p>50 units</p>
 <p>8WH2 003-0AF00</p> <p><b>Through-type terminals, terminal size 2.5 mm<sup>2</sup>, three clamping points</b></p> <ul style="list-style-type: none"> <li>Terminal width 5.2 mm</li> <li>CSUs</li> <li>IEC 60947-7-1                     <ul style="list-style-type: none"> <li>Rigid 0.08 ... 4 mm<sup>2</sup></li> <li>Flexible 0.08 ... 2.5 mm<sup>2</sup></li> <li>AWG 28-12</li> <li>I = 28 A</li> </ul> </li> <li>The total current through all connected conductors must not exceed the max. load current</li> <li>U = 800 V</li> </ul> <p><b>Versions</b></p> <ul style="list-style-type: none"> <li>Gray</li> <li>Blue</li> </ul>	<p><b>8WH2 003-0AF00</b></p> <p><b>8WH2 003-0AF01</b></p>	<p>50 units</p> <p>50 units</p>
 <p>8WH2 004-0AF00</p> <p><b>Through-type terminals, terminal size 2.5 mm<sup>2</sup>, four clamping points</b></p> <ul style="list-style-type: none"> <li>Terminal width 5.2 mm</li> <li>CSUs</li> <li>IEC 60947-7-1                     <ul style="list-style-type: none"> <li>Rigid 0.08 ... 4 mm<sup>2</sup></li> <li>Flexible 0.08 ... 2.5 mm<sup>2</sup></li> <li>AWG 28-12</li> <li>I = 28 A</li> </ul> </li> <li>The total current through all connected conductors must not exceed the max. load current</li> <li>U = 800 V</li> </ul> <p><b>Versions</b></p> <ul style="list-style-type: none"> <li>Gray</li> <li>Blue</li> </ul>	<p><b>8WH2 004-0AF00</b></p> <p><b>8WH2 004-0AF01</b></p>	<p>50 units</p> <p>50 units</p>

\* You can order this quantity or a multiple thereof.





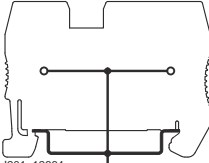

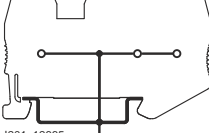
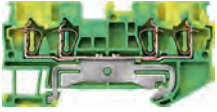
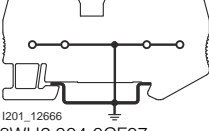
# 8WH2 Spring-Loaded Terminals

## 8WH through-type terminals

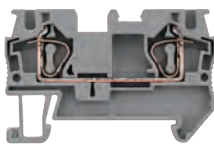
4

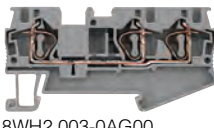
	Version	Order No.	MOQ*
	<p><b>PE through-type terminals, terminal size 2.5 mm²</b></p> <ul style="list-style-type: none"> <li>Terminal width 5.2 mm</li> <li>UL</li> <li>IEC 60947-7-2             <ul style="list-style-type: none"> <li>Rigid 0.08 ... 4 mm²</li> <li>Flexible 0.08 ... 2.5 mm²</li> <li>AWG 28-12</li> </ul> </li> <li>Green/yellow</li> </ul>		
	<p><b>Versions</b></p> <ul style="list-style-type: none"> <li>Two clamping points</li> <li>Three clamping points</li> <li>Four clamping points</li> </ul>		
		<p><b>8WH2 000-OCF07</b>  <b>8WH2 003-OCF07</b>  <b>8WH2 004-OCF07</b></p>	<p>50 units            50 units            50 units</p>
<p>I201_12664 8WH2 000-OCF07</p>			
			
<p>8WH2 003-OCF07</p>			
			
<p>I201_12665 8WH2 003-OCF07</p>			
			
<p>8WH2 004-OCF07</p>			
			
<p>I201_12666 8WH2 004-OCF07</p>			

\* You can order this quantity or a multiple thereof.





Version	Order No.	MOQ*
<b>Terminal size 4 mm<sup>2</sup></b>		
 <p>8WH2 000-0AG00</p> <p><b>Through-type terminals, terminal size 4 mm<sup>2</sup>, two clamping points</b></p> <ul style="list-style-type: none"> <li>Terminal width 6.2 mm</li> <li>  </li> <li>IEC 60947-7-1                     <ul style="list-style-type: none"> <li>Rigid 0.08 ... 6 mm<sup>2</sup>, flexible 0.08 ... 4 mm<sup>2</sup>, AWG 28-10</li> <li><math>I = 40\text{ A}</math>, <math>U = 800\text{ V}</math></li> </ul> </li> </ul> <p>Versions</p> <ul style="list-style-type: none"> <li>Gray</li> <li>Blue</li> <li>Orange</li> <li>Red</li> <li>Black</li> <li>Green</li> <li>White</li> <li>Yellow</li> </ul>	<p>8WH2 000-0AG00</p> <p>8WH2 000-0AG01</p> <p>8WH2 000-0AG04</p> <p>8WH2 000-0AG02</p> <p>8WH2 000-0AG08</p> <p>8WH2 000-0AG03</p> <p>8WH2 000-0AG05</p> <p>8WH2 000-0AG06</p>	<p>50 units</p> <p>50 units</p> <p>50 units</p> <p>50 units</p> <p>50 units</p> <p>50 units</p> <p>50 units</p>
 <p>8WH2 003-0AG00</p> <p><b>Through-type terminals, terminal size 4 mm<sup>2</sup>, three clamping points</b></p> <ul style="list-style-type: none"> <li>Terminal width 6.2 mm</li> <li>  </li> <li>IEC 60947-7-1                     <ul style="list-style-type: none"> <li>Rigid 0.08 ... 6 mm<sup>2</sup>, flexible 0.08 ... 4 mm<sup>2</sup>, AWG 28-10</li> <li><math>I = 40\text{ A}</math>, the total current through all connected conductors must not exceed the max. load current</li> <li><math>U = 800\text{ V}</math></li> </ul> </li> </ul> <p>Versions</p> <ul style="list-style-type: none"> <li>Gray</li> <li>Blue</li> </ul>	<p>8WH2 003-0AG00</p> <p>8WH2 003-0AG01</p>	<p>50 units</p> <p>50 units</p>
 <p>8WH2 004-0AG00</p> <p><b>Through-type terminals, terminal size 4 mm<sup>2</sup>, four clamping points</b></p> <ul style="list-style-type: none"> <li>Terminal width 6.2 mm</li> <li>  </li> <li>IEC 60947-7-1                     <ul style="list-style-type: none"> <li>Rigid 0.08 ... 6 mm<sup>2</sup>, flexible 0.08 ... 4 mm<sup>2</sup>, AWG 28-10</li> <li><math>I = 40\text{ A}</math>, the total current through all connected conductors must not exceed the max. load current</li> <li><math>U = 800\text{ V}</math></li> </ul> </li> </ul> <p>Versions</p> <ul style="list-style-type: none"> <li>Gray</li> <li>Blue</li> </ul>	<p>8WH2 004-0AG00</p> <p>8WH2 004-0AG01</p>	<p>50 units</p> <p>50 units</p>

\* You can order this quantity or a multiple thereof.



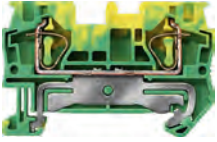
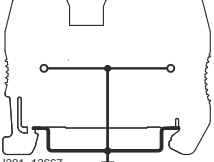

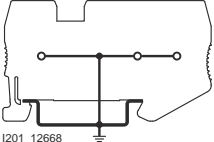

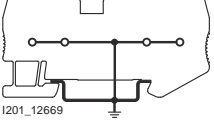

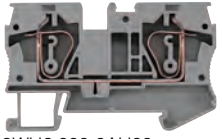

# 8WH2 Spring-Loaded Terminals

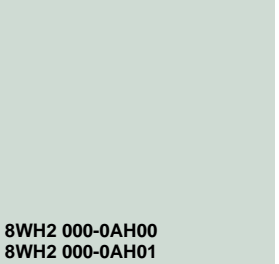
## 8WH through-type terminals

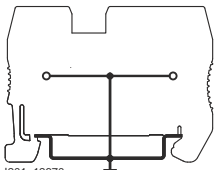
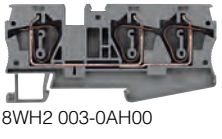
4

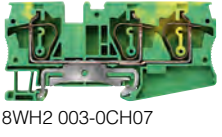
	Version	Order No.	MOQ*
 <p>8WH2 000-0CG07</p>	<p><b>PE through-type terminals, terminal size 4 mm²</b></p> <ul style="list-style-type: none"> <li>Terminal width 6.2 mm</li> <li>UL US</li> <li>IEC 60947-7-2                     <ul style="list-style-type: none"> <li>Rigid 0.08 ... 6 mm²</li> <li>Flexible 0.08 ... 4 mm²</li> <li>AWG 28-10</li> </ul> </li> <li>Green/yellow</li> </ul>		
 <p>1201_12667 8WH2 000-0CE07</p>	<p><b>Versions</b></p> <ul style="list-style-type: none"> <li>Two clamping points</li> <li>Three clamping points</li> <li>Four clamping points</li> </ul>	<p><b>8WH2 000-0CG07</b> <b>8WH2 003-0CG07</b> <b>8WH2 004-0CG07</b></p>	<p>50 units 50 units 50 units</p>
 <p>8WH2 003-0CG07</p>			
 <p>1201_12668 8WH2 003-0CG07</p>			
 <p>8WH2 004-0CG07</p>			
 <p>1201_12669 8WH2 004-0CG07</p>			

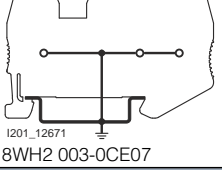
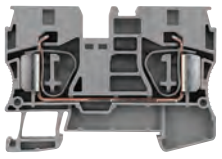
\* You can order this quantity or a multiple thereof.

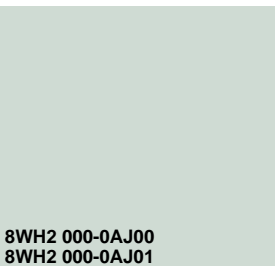





Version	Order No.	MOQ*
<b>Terminal size 6 mm<sup>2</sup></b>		
 <p>8WH2 000-0AH00</p> <p><b>Through-type terminals, terminal size 6 mm<sup>2</sup>, two clamping points</b></p> <ul style="list-style-type: none"> <li>Terminal width 8.2 mm</li> <li>  </li> <li>IEC 60947-7-1                     <ul style="list-style-type: none"> <li>Rigid 0.2 ... 10 mm<sup>2</sup></li> <li>Flexible 0.2 ... 6 mm<sup>2</sup></li> <li>AWG 24-8</li> <li>I = 52 A</li> <li>U = 1000 V</li> </ul> </li> </ul> <p>Versions</p> <ul style="list-style-type: none"> <li>Gray</li> <li>Blue</li> </ul>	 <p>8WH2 000-0AH00</p> <p>8WH2 000-0AH01</p>	<p>50 units</p> <p>50 units</p>
 <p>8WH2 000-0CH07</p> <p><b>PE through-type terminals, terminal size 6 mm<sup>2</sup>, two clamping points</b></p> <ul style="list-style-type: none"> <li>Terminal width 8.2 mm</li> <li>  </li> <li>IEC 60947-7-2                     <ul style="list-style-type: none"> <li>Rigid 0.2 ... 10 mm<sup>2</sup></li> <li>Flexible 0.2 ... 6 mm<sup>2</sup></li> <li>AWG 24-8</li> </ul> </li> <li>Green/yellow</li> </ul>		8WH2 000-0CH07
 <p>1201_12670</p> <p>8WH2 000-0CE07</p>		
 <p>8WH2 003-0AH00</p> <p><b>Through-type terminals, terminal size 6 mm<sup>2</sup>, three clamping points</b></p> <ul style="list-style-type: none"> <li>Terminal width 8.2 mm</li> <li>  </li> <li>IEC 60947-7-1                     <ul style="list-style-type: none"> <li>Rigid 0.2 ... 10 mm<sup>2</sup></li> <li>Flexible 0.2 ... 6 mm<sup>2</sup></li> <li>AWG 24-8</li> <li>I = 52 A</li> <li>The total current through all connected conductors must not exceed the max. load current</li> <li>U = 1000 V</li> </ul> </li> </ul> <p>Versions</p> <ul style="list-style-type: none"> <li>Gray</li> <li>Blue</li> </ul>	 <p>8WH2 003-0AH00</p> <p>8WH2 003-0AH01</p>	<p>50 units</p> <p>50 units</p>
 <p>8WH2 003-0CH07</p> <p><b>PE through-type terminals, terminal size 6 mm<sup>2</sup>, three clamping points</b></p> <ul style="list-style-type: none"> <li>Terminal width 8.2 mm</li> <li>  </li> <li>IEC 60947-7-2                     <ul style="list-style-type: none"> <li>Rigid 0.2 ... 10 mm<sup>2</sup></li> <li>Flexible 0.2 ... 6 mm<sup>2</sup></li> <li>AWG 24-8</li> </ul> </li> <li>Green/yellow</li> </ul>		8WH2 003-0CH07
 <p>1201_12671</p> <p>8WH2 003-0CE07</p>		
<b>Terminal size 10 mm<sup>2</sup></b>		
 <p>8WH2 000-0AJ00</p> <p><b>Through-type terminals, terminal size 10 mm<sup>2</sup></b></p> <ul style="list-style-type: none"> <li>Terminal width 10.2 mm</li> <li>  </li> <li>IEC 60947-7-1                     <ul style="list-style-type: none"> <li>Rigid 1.5 ... 16 mm<sup>2</sup></li> <li>Flexible 1.5 ... 10 mm<sup>2</sup></li> <li>AWG 24-6</li> <li>I = 65 A</li> <li>U = 1000 V</li> </ul> </li> </ul> <p>Versions</p> <ul style="list-style-type: none"> <li>Gray</li> <li>Blue</li> </ul>	 <p>8WH2 000-0AJ00</p> <p>8WH2 000-0AJ01</p>	<p>50 units</p> <p>50 units</p>



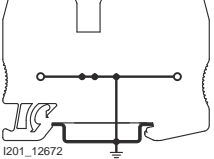

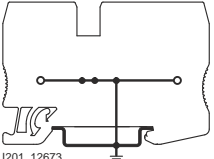

\* You can order this quantity or a multiple thereof.

# 8WH2 Spring-Loaded Terminals

## 8WH through-type terminals

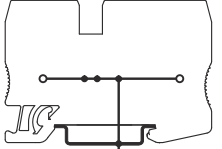
4

	Version	Order No.	MOQ*
 <p>8WH2 000-0CJ07</p>  <p>1201_12672 8WH2 000-0CJ07</p>	<p><b>PE through-type terminals, terminal size 10 mm<sup>2</sup></b></p> <ul style="list-style-type: none"> <li>Terminal width 10.2 mm</li> <li>  </li> <li>IEC 60947-7-2           <ul style="list-style-type: none"> <li>Rigid 1.5 ... 16 mm<sup>2</sup></li> <li>Flexible 1.5 ... 10 mm<sup>2</sup></li> <li>AWG 24-6</li> <li>I = 65 A</li> </ul> </li> <li>Green/yellow</li> </ul>	<p><b>8WH2 000-0CJ07</b></p>	<p>50 units</p>
<p><b>Terminal size 16 mm<sup>2</sup></b></p>			
 <p>8WH2 000-0AK00</p>	<p><b>Through-type terminals, terminal size 16 mm<sup>2</sup></b></p> <ul style="list-style-type: none"> <li>Terminal width 12 mm</li> <li>  </li> <li>IEC 60947-7-1           <ul style="list-style-type: none"> <li>Rigid 1.5 ... 25 mm<sup>2</sup></li> <li>Flexible 1.5 ... 16 mm<sup>2</sup></li> <li>AWG 24-4</li> <li>I = 90 A</li> <li>U = 1000 V</li> </ul> </li> </ul> <p><b>Versions</b></p> <ul style="list-style-type: none"> <li>Gray</li> <li>Blue</li> </ul>	<p><b>8WH2 000-0AK00</b> <b>8WH2 000-0AK01</b></p>	<p>50 units 50 units</p>
 <p>8WH2 000-0CK07</p>  <p>1201_12673 8WH2 000-0CK07</p>	<p><b>PE through-type terminals, terminal size 16 mm<sup>2</sup></b></p> <ul style="list-style-type: none"> <li>Terminal width 12 mm</li> <li>  </li> <li>IEC 60947-7-2           <ul style="list-style-type: none"> <li>Rigid 1.5 ... 25 mm<sup>2</sup></li> <li>Flexible 1.5 ... 16 mm<sup>2</sup></li> <li>AWG 24-4</li> <li>I = 90 A</li> </ul> </li> <li>Green/yellow</li> </ul>	<p><b>8WH2 000-0CK07</b></p>	<p>25 units</p>

Version	Order No.	MOQ*
<b>Terminal size 35 mm<sup>2</sup></b>		
 <p>8WH2 000-0AM00</p> <p><b>Through-type terminals, terminal size 35 mm<sup>2</sup></b></p> <ul style="list-style-type: none"> <li>Terminal width 16 mm</li> <li>UL: CS</li> <li>IEC 60947-7-1                     <ul style="list-style-type: none"> <li>Rigid 2.5 ... 35 mm<sup>2</sup></li> <li>Flexible 2.5 ... 35 mm<sup>2</sup></li> <li>AWG 14-2</li> <li>I = 125 A</li> <li>U = 1000 V</li> </ul> </li> <li>Enclosed at both ends</li> </ul> <p>Versions</p> <ul style="list-style-type: none"> <li>Gray, ☉</li> <li>Blue</li> </ul>	<p>8WH2 000-0AM00</p> <p>8WH2 000-0AM01</p>	<p>10 units</p> <p>10 units</p>
 <p>8WH2 000-0CM07</p> <p><b>PE through-type terminals, terminal size 35 mm<sup>2</sup></b></p> <ul style="list-style-type: none"> <li>Terminal width 16 mm</li> <li>UL: CS, CE</li> <li>IEC 60947-7-2                     <ul style="list-style-type: none"> <li>Rigid 2.5 ... 35 mm<sup>2</sup></li> <li>Flexible 2.5 ... 35 mm<sup>2</sup></li> <li>AWG 14-2</li> <li>I = 125 A</li> </ul> </li> <li>Enclosed at both ends</li> <li>Green/yellow</li> </ul> <p>Versions</p> <ul style="list-style-type: none"> <li>Green/yellow</li> </ul>  <p>1201_12674</p> <p>8WH2 000-0CM07</p>	<p>8WH2 000-0CM07</p>	<p>10 units</p>
<b>Accessories</b>		
 <p>8WH9 070-0AA00</p> <p><b>Compartment partitions</b></p> <ul style="list-style-type: none"> <li>For visual and electrical separation of terminal groups</li> <li>2 mm thick</li> </ul> <p>Versions</p> <ul style="list-style-type: none"> <li>For terminal size 1.5 ... 4 mm<sup>2</sup> and two clamping points</li> <li>For terminal size 1.5 ... 4 mm<sup>2</sup> and three clamping points</li> <li>For terminal size 1.5 ... 4 mm<sup>2</sup> and four clamping points</li> <li>For terminal size 6 mm<sup>2</sup></li> </ul>	<p>8WH9 070-0AA00</p> <p>8WH9 070-0GA00</p> <p>8WH9 070-0HA00</p> <p>8WH9 070-0DA00</p>	<p>50 units</p> <p>50 units</p> <p>50 units</p> <p>50 units</p>
 <p>8WH9 000-1GA00</p> <p><b>Covers</b></p> <p>Gray</p> <p>Versions</p> <ul style="list-style-type: none"> <li>For terminal size 1.5 ... 2.5 mm<sup>2</sup> and two clamping points</li> <li>For terminal size 1.5 ... 2.5 mm<sup>2</sup> and three clamping points</li> <li>For terminal size 1.5 ... 2.5 mm<sup>2</sup> and four clamping points</li> <li>For terminal size 4 mm<sup>2</sup> and two clamping points</li> <li>For terminal size 4 mm<sup>2</sup> and three clamping points</li> <li>For terminal size 4 mm<sup>2</sup> and four clamping points</li> <li>For terminal size 6 mm<sup>2</sup> and two clamping points</li> <li>For terminal size 6 mm<sup>2</sup> and three clamping points</li> <li>For terminal size 10 mm<sup>2</sup></li> <li>For terminal size 16 mm<sup>2</sup></li> </ul>	<p>8WH9 000-1GA00</p> <p>8WH9 000-2GA00</p> <p>8WH9 000-4GA00</p> <p>8WH9 003-1GA00</p> <p>8WH9 003-2GA00</p> <p>8WH9 003-4GA00</p> <p>8WH9 004-1GA00</p> <p>8WH9 004-2GA00</p> <p>8WH9 005-1GA00</p> <p>8WH9 006-1GA00</p>	<p>50 units</p> <p>50 units</p> <p>50 units</p> <p>50 units</p> <p>50 units</p> <p>50 units</p> <p>50 units</p> <p>50 units</p> <p>50 units</p>
 <p>8WH9 000-0GA00</p> <p><b>Cover segments</b></p> <ul style="list-style-type: none"> <li>Gray</li> <li>For covering multi-wire terminals when mounting two-wire terminals side-by-side</li> </ul> <p>Versions</p> <ul style="list-style-type: none"> <li>For terminal size 1.5 ... 2.5 mm<sup>2</sup></li> <li>For terminal size 4 mm<sup>2</sup></li> </ul>	<p>8WH9 000-0GA00</p> <p>8WH9 003-0GA00</p>	<p>10 units</p> <p>10 units</p>
 <p>8WH9 061-5AA06</p> <p><b>Warning covers</b></p> <p>Note: For the operating shafts of 8WH2 through-type terminals</p> <p>Versions</p> <ul style="list-style-type: none"> <li>For terminal size 1.5 mm<sup>2</sup></li> <li>For terminal size 2.5 mm<sup>2</sup></li> <li>For terminal size 4 mm<sup>2</sup></li> <li>For terminal size 6 mm<sup>2</sup></li> <li>For terminal size 10 mm<sup>2</sup></li> <li>For terminal size 16 mm<sup>2</sup></li> <li>For terminal size 35 mm<sup>2</sup></li> </ul>	<p>8WH9 061-5AA06</p> <p>8WH9 060-5AA06</p> <p>8WH9 063-5AA06</p> <p>8WH9 064-5AA06</p> <p>8WH9 065-5AA06</p> <p>8WH9 066-5AA06</p> <p>8WH9 067-5AA06</p>	<p>50 units</p> <p>50 units</p> <p>50 units</p> <p>10 units</p> <p>25 units</p> <p>25 units</p> <p>10 units</p>







Note:  
For general accessories for 8WH terminal blocks, see chapter 8.



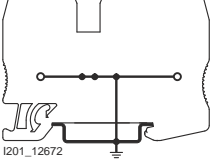

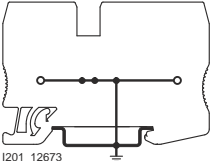

\* You can order this quantity or a multiple thereof.

# 8WH2 Spring-Loaded Terminals

## 8WH through-type terminals

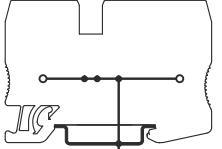
4

	Version	Order No.	MOQ*
 <p>8WH2 000-0CJ07</p>  <p>1201_12672 8WH2 000-0CJ07</p>	<p><b>PE through-type terminals, terminal size 10 mm<sup>2</sup></b></p> <ul style="list-style-type: none"> <li>Terminal width 10.2 mm</li> <li>  </li> <li>IEC 60947-7-2           <ul style="list-style-type: none"> <li>Rigid 1.5 ... 16 mm<sup>2</sup></li> <li>Flexible 1.5 ... 10 mm<sup>2</sup></li> <li>AWG 24-6</li> <li>I = 65 A</li> </ul> </li> <li>Green/yellow</li> </ul>	<p><b>8WH2 000-0CJ07</b></p>	<p>50 units</p>
<p><b>Terminal size 16 mm<sup>2</sup></b></p>			
 <p>8WH2 000-0AK00</p>	<p><b>Through-type terminals, terminal size 16 mm<sup>2</sup></b></p> <ul style="list-style-type: none"> <li>Terminal width 12 mm</li> <li>  </li> <li>IEC 60947-7-1           <ul style="list-style-type: none"> <li>Rigid 1.5 ... 25 mm<sup>2</sup></li> <li>Flexible 1.5 ... 16 mm<sup>2</sup></li> <li>AWG 24-4</li> <li>I = 90 A</li> <li>U = 1000 V</li> </ul> </li> </ul> <p><b>Versions</b></p> <ul style="list-style-type: none"> <li>Gray</li> <li>Blue</li> </ul>	<p><b>8WH2 000-0AK00</b> <b>8WH2 000-0AK01</b></p>	<p>50 units 50 units</p>
 <p>8WH2 000-0CK07</p>  <p>1201_12673 8WH2 000-0CK07</p>	<p><b>PE through-type terminals, terminal size 16 mm<sup>2</sup></b></p> <ul style="list-style-type: none"> <li>Terminal width 12 mm</li> <li>  </li> <li>IEC 60947-7-2           <ul style="list-style-type: none"> <li>Rigid 1.5 ... 25 mm<sup>2</sup></li> <li>Flexible 1.5 ... 16 mm<sup>2</sup></li> <li>AWG 24-4</li> <li>I = 90 A</li> </ul> </li> <li>Green/yellow</li> </ul>	<p><b>8WH2 000-0CK07</b></p>	<p>25 units</p>

Version	Order No.	MOQ*
<b>Terminal size 35 mm<sup>2</sup></b>		
 8WH2 000-0AM00	<b>Through-type terminals, terminal size 35 mm<sup>2</sup></b> <ul style="list-style-type: none"> <li>Terminal width 16 mm</li> <li>UL: Ⓢ</li> <li>IEC 60947-7-1                             <ul style="list-style-type: none"> <li>Rigid 2.5 ... 35 mm<sup>2</sup></li> <li>Flexible 2.5 ... 35 mm<sup>2</sup></li> <li>AWG 14-2</li> <li>I = 125 A</li> <li>U = 1000 V</li> </ul> </li> <li>Enclosed at both ends</li> </ul> <b>Versions</b> <ul style="list-style-type: none"> <li>Gray, Ⓢ</li> <li>Blue</li> </ul>	8WH2 000-0AM00 10 units 8WH2 000-0AM01 10 units
 8WH2 000-0CM07	<b>PE through-type terminals, terminal size 35 mm<sup>2</sup></b> <ul style="list-style-type: none"> <li>Terminal width 16 mm</li> <li>UL: Ⓢ, Ⓢ</li> <li>IEC 60947-7-2                             <ul style="list-style-type: none"> <li>Rigid 2.5 ... 35 mm<sup>2</sup></li> <li>Flexible 2.5 ... 35 mm<sup>2</sup></li> <li>AWG 14-2</li> <li>I = 125 A</li> </ul> </li> <li>Enclosed at both ends</li> <li>Green/yellow</li> </ul>	8WH2 000-0CM07 10 units
 I201_12674 8WH2 000-0CM07		
<b>Accessories</b>		
 8WH9 070-0AA00	<b>Compartment partitions</b> <ul style="list-style-type: none"> <li>For visual and electrical separation of terminal groups</li> <li>2 mm thick</li> </ul> <b>Versions</b> <ul style="list-style-type: none"> <li>For terminal size 1.5 ... 4 mm<sup>2</sup> and two clamping points</li> <li>For terminal size 1.5 ... 4 mm<sup>2</sup> and three clamping points</li> <li>For terminal size 1.5 ... 4 mm<sup>2</sup> and four clamping points</li> <li>For terminal size 6 mm<sup>2</sup></li> </ul>	8WH9 070-0AA00 50 units 8WH9 070-0GA00 50 units 8WH9 070-0HA00 50 units 8WH9 070-0DA00 50 units
 8WH9 000-1GA00	<b>Covers</b> Gray	
	<b>Versions</b> <ul style="list-style-type: none"> <li>For terminal size 1.5 ... 2.5 mm<sup>2</sup> and two clamping points</li> <li>For terminal size 1.5 ... 2.5 mm<sup>2</sup> and three clamping points</li> <li>For terminal size 1.5 ... 2.5 mm<sup>2</sup> and four clamping points</li> <li>For terminal size 4 mm<sup>2</sup> and two clamping points</li> <li>For terminal size 4 mm<sup>2</sup> and three clamping points</li> <li>For terminal size 4 mm<sup>2</sup> and four clamping points</li> <li>For terminal size 6 mm<sup>2</sup> and two clamping points</li> <li>For terminal size 6 mm<sup>2</sup> and three clamping points</li> <li>For terminal size 10 mm<sup>2</sup></li> <li>For terminal size 16 mm<sup>2</sup></li> </ul>	8WH9 000-1GA00 50 units 8WH9 000-2GA00 50 units 8WH9 000-4GA00 50 units 8WH9 003-1GA00 50 units 8WH9 003-2GA00 50 units 8WH9 003-4GA00 50 units 8WH9 004-1GA00 50 units 8WH9 004-2GA00 50 units 8WH9 005-1GA00 50 units 8WH9 006-1GA00 50 units
 8WH9 000-0GA00	<b>Cover segments</b> <ul style="list-style-type: none"> <li>Gray</li> <li>For covering multi-wire terminals when mounting two-wire terminals side-by-side</li> </ul> <b>Versions</b> <ul style="list-style-type: none"> <li>For terminal size 1.5 ... 2.5 mm<sup>2</sup></li> <li>For terminal size 4 mm<sup>2</sup></li> </ul>	8WH9 000-0GA00 10 units 8WH9 003-0GA00 10 units
 8WH9 061-5AA06	<b>Warning covers</b> Note: For the operating shafts of 8WH2 through-type terminals	
	<b>Versions</b> <ul style="list-style-type: none"> <li>For terminal size 1.5 mm<sup>2</sup></li> <li>For terminal size 2.5 mm<sup>2</sup></li> <li>For terminal size 4 mm<sup>2</sup></li> <li>For terminal size 6 mm<sup>2</sup></li> <li>For terminal size 10 mm<sup>2</sup></li> <li>For terminal size 16 mm<sup>2</sup></li> <li>For terminal size 35 mm<sup>2</sup></li> </ul>	8WH9 061-5AA06 50 units 8WH9 060-5AA06 50 units 8WH9 063-5AA06 50 units 8WH9 064-5AA06 10 units 8WH9 065-5AA06 25 units 8WH9 066-5AA06 25 units 8WH9 067-5AA06 10 units

Note:  
For general accessories for 8WH terminal blocks, see chapter 8.

\* You can order this quantity or a multiple thereof.

# 8WH2 Spring-Loaded Terminals

## 8WH hybrid through-type terminals

### Overview

4

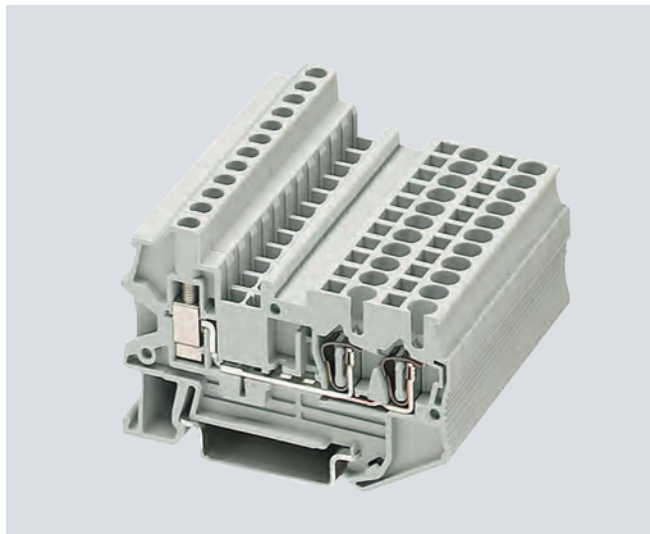

The terminal connection compartment, on the spring-loaded side as well as on the screw side, enables connection to a nominal cross-section of 2.5 mm<sup>2</sup> or 4 mm<sup>2</sup>, with or without end sleeves. The advantages of the different connection types are due to the fact that the spring-loaded terminal of the hybrid through-type terminal is used inside the control cabinet and the universal screw terminal is used at the end-user's side. A PE terminal with the same contour is available for the three-wire terminal. Contact is made by simply snapping the terminal onto the support rail.

This meets the requirements of IEC 60947-7-2:



- Low contact resistance
- Stainless clamping points
- Green-yellow enclosure
- Additional inscription options.

A label can be snapped on to the middle of each terminal at the front. Further labels can also be mounted flat on the side of the terminals.

### Technical specifications

	8WH2 103-2BF00 8WH2 103-2BF01	8WH2 103-3BF07	8WH2 103-2BG00 8WH2 103-2BG01	8WH2 103-3BG07
Dimensions				
• Width/length/cover width in mm	5.2 / 65.3 / 2.2		6.2 / 74.4 / 2.2	
• Height (NS 35/7.5 / NS 35/15) in mm	42.8 / 50.3			
Technical specifications acc. to IEC/DIN VDE				
• Max. load current in A / cross-section in mm <sup>2</sup>	28 / 4	--	32 / 6	--
• Rated impulse withstand voltage in kV / pollution degree	8 / 3			
• Overvoltage category / molded plastic group	III / I			
Connection capacities				
• Flexible with end sleeve, with plastic sleeve in mm <sup>2</sup>	0.25 ... 2.5		0.25 ... 4	
• Flexible with end sleeve, without plastic sleeve in mm <sup>2</sup>	0.25 ... 2.5		0.25 ... 4	
• Flexible with two-wire connection end sleeve, with plastic sleeve in mm <sup>2</sup>	0.5 ... 1			
Stripped length in mm	10			
Plug gauge (IEC 60947-1)	A3		A4	
Connection capacity of screw terminal				
• Flexible with end sleeves with/without plastic sleeve in mm <sup>2</sup>	0.25 ... 2.5 / 0.25 ... 2.5		0.25 ... 4 / 0.25 ... 4	
Multi-conductor connection (two conductors of same cross-section)				
• Rigid/flexible in mm <sup>2</sup>	0.14 ... 1.5 / 0.14 ... 1.5			
• Flexible with end sleeve, without plastic sleeve in mm <sup>2</sup>	0.25 ... 1.5			
• Flexible with two-wire connection end sleeve, with plastic sleeve in mm <sup>2</sup>	0.5 ... 1.5		0.5 ... 2.5	
Stripped length in mm	9			
Plug gauge (IEC 60947-1)	A3		A4	
Tightening torque in Nm	0.6 ... 0.8		0.6...0.8	
Molded plastic type	PA			
• Flammability class acc. to UL 94	V0			
Approval data (UL/cUL and CSA)				
• Rated voltage / rated current / conductor sizes				
- UL/cUL: in V/A / AWG	Applied for			
- CSA: in V/A / AWG	Applied for			
Support rails/protective conductor busbars	--	See section "Support rails" on page 1/3	--	See section "Support rails" on page 1/3

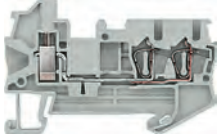
### Selection and ordering data

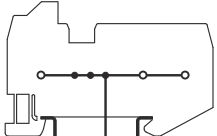
Version	Order No.	MOQ*	
<b>Terminal size 2.5 mm<sup>2</sup></b>			
 <p>8WH2 103-2BF00</p> <p><b>Hybrid through-type terminals, terminal size 2.5 mm<sup>2</sup></b></p> <ul style="list-style-type: none"> <li>• Terminal width 5.2 mm</li> <li>• IEC 60947-7-1</li> <li>• Spring                             <ul style="list-style-type: none"> <li>- Rigid 0.08 ... 4 mm<sup>2</sup></li> <li>- Flexible 0.08 ... 2.5 mm<sup>2</sup></li> <li>- AWG 28-12</li> <li>- <math>I = 28</math> A</li> <li>- The total current through all connected conductors must not exceed the max. load current</li> <li>- <math>U = 800</math> V</li> </ul> </li> <li>• Screw                             <ul style="list-style-type: none"> <li>- Rigid 0.14 ... 4 mm<sup>2</sup></li> <li>- Flexible 0.14 ... 2.5 mm<sup>2</sup></li> <li>- AWG 26-14</li> <li>- <math>I = 28</math> A</li> <li>- <math>U = 800</math> V</li> </ul> </li> </ul> <p><b>Versions</b></p> <ul style="list-style-type: none"> <li>• Gray</li> <li>• Blue</li> </ul>		<p><b>8WH2 103-2BF00</b></p> <p><b>8WH2 103-2BF01</b></p>	<p>50 units</p> <p>50 units</p>
 <p>8WH2 103-3BF07</p> <p><b>PE hybrid through-type terminals, terminal size 2.5 mm<sup>2</sup></b></p> <ul style="list-style-type: none"> <li>• Terminal width 5.2 mm</li> <li>• IEC 60947-7-2</li> <li>• Spring                             <ul style="list-style-type: none"> <li>- Rigid 0.08 ... 4 mm<sup>2</sup></li> <li>- Flexible 0.08 ... 2.5 mm<sup>2</sup></li> <li>- AWG 28-12</li> </ul> </li> <li>• Screw                             <ul style="list-style-type: none"> <li>- Rigid 0.14 ... 4 mm<sup>2</sup></li> <li>- Flexible 0.14 ... 2.5 mm<sup>2</sup></li> <li>- AWG 26-14</li> </ul> </li> </ul> <p><b>Versions</b></p> <ul style="list-style-type: none"> <li>• Gray</li> <li>• Blue</li> </ul>		<p><b>8WH2 103-3BF07</b></p>	<p>50 units</p>
 <p>1201_12675</p> <p>8WH2 103-3BF07</p>			

\* You can order this quantity or a multiple thereof.

# 8WH2 Spring-Loaded Terminals

## 8WH hybrid through-type terminals

4

### Terminal size 4 mm<sup>2</sup>



8WH2 103-2BG00

#### Hybrid through-type terminals, terminal size 4 mm<sup>2</sup>

- Terminal width 6.2 mm
- IEC 60947-7-1
- Spring
  - Rigid 0.08 ... 6 mm<sup>2</sup>
  - Flexible 0.08 ... 4 mm<sup>2</sup>
  - AWG 28-10
  - $I = 32$  A
  - The total current through all connected conductors must not exceed the max. load current
  - $U = 800$  V
- Screw
  - Rigid 0.14 ... 6 mm<sup>2</sup>
  - Flexible 0.14 ... 4 mm<sup>2</sup>
  - AWG 26-10
  - $I = 32$  A
  - $U = 800$  V

#### Versions

- Gray
- Blue

Order No.      MOQ\*

8WH2 103-2BG00	50 units
8WH2 103-2BG01	50 units



8WH2 103-3BG07

#### PE hybrid through-type terminals, terminal size 4 mm<sup>2</sup>

- Terminal width 6.2 mm
- IEC 60947-7-2
- Spring
  - Rigid 0.08 ... 6 mm<sup>2</sup>
  - Flexible 0.08 ... 4 mm<sup>2</sup>
  - AWG 28-10
- Screw
  - Rigid 0.14 ... 6 mm<sup>2</sup>
  - Flexible 0.14 ... 4 mm<sup>2</sup>
  - AWG 26-10

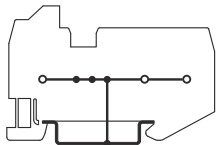

1201\_12676  
8WH2 103-3BG07

8WH2 103-3BG07      50 units

### Accessories



8WH9 000-2HA00

#### Covers

Gray

#### Versions

- For terminal size 2.5 mm<sup>2</sup> and three clamping points
- For terminal size 4 mm<sup>2</sup> and three clamping points

8WH9 000-2HA00      50 units  
8WH9 003-2HA00      50 units

Note:

For general accessories for 8WH terminal blocks, [see chapter 8](#).

### Overview



#### Fuse terminals for blade-type fuses

The fuse terminals for blade-type fuses accommodate blade-type fuses according to ISO/DIS 8820 / DIN 72581-3. Terminals with LED display are available for fast fault diagnosis "at a glance".

#### Fuse terminals for G fuse links

Fuse terminals perform two important tasks in connected electrical systems. Firstly, they act as a fuse carrier and, secondly, as a potential distributor.

The full-length bridge shaft enables uninterrupted bridging between the through-type terminals and the fuse terminals.

Fuse terminals for G fuse links are available for standardized electrical fuse formats 5 × 20 mm and 6.3 × 32 mm (inch fuse) – and are optionally available with LED display to signal a blown fuse.

A label can be snapped on to the middle of the terminal at the front. Further labels can also be mounted flat on the side of the terminals.

### Technical specifications

	8WH2 000-1AG08 8WH2 000-1BG28 8WH2 000-1BG38	8WH2 000-1GG08 8WH2 000-1JG38 8WH2 000-1JG68 8WH2 000-1MG08	8WH2 000-1HG08 8WH2 000-1NG38 8WH2 000-1NG68 8WH2 000-1RG08
Dimensions			
• Width/length in mm	8.2 / 86.5	6.2 / 61.5	8.2 / 76.5
• Height (NS 35/7.5 / NS 35/15) in mm	43.5 / 51	62.5 / 70	69 / 76.5
Technical specifications acc. to IEC/DIN VDE			
• Fuse type ISO/DIS 8820 / DIN 72581-3 / dimensions / in mm	C	G / 5 × 20	G / 6.3 × 32
• Maximum current for single arrangement in A	30	3.3	10
Max. power loss at 23 °C acc. to IEC 60647-7-3 in W <sup>1)</sup>			
• U in V	--	250	400
• Overload protection			
- Individually in W	--	1.6	
- As group in W	--	1.6	
• Without short-circuit protection			
- Individually in W	--	4	
- As group in W	--	2.5	
• I <sub>max</sub> in A	--	6.3	10
• Rated impulse withstand voltage in kV / pollution degree	6 / 3	4 / 3	6 / 3
• Overvoltage category / molded plastic group	III / I		
Connection capacities			
• Flexible with end sleeve without/with plastic sleeve in mm <sup>2</sup>	0.25 ... 4 / 0.25 ... 4		
• Flexible with two-wire connection end sleeve, with plastic sleeve in mm <sup>2</sup>	0.5		
Stripped length in mm	10		
Plug gauge (IEC 60947-1)	A4	A3	A4
Molded plastic type	PA		
• Flammability class acc. to UL 94	V0		
Approval data (UL/cUL and CSA)			
• Rated voltage / rated current / conductor sizes			
- UL/cUL: in V/A / AWG	600 / 30 / 24-10	300 / 6.3 / 24-10	300 / 10 / 24-10
- CSA: in V/A / AWG	--		







<sup>1)</sup> Please note: The G fuse holders must be selected according to the maximum power loss (heat dissipation) of the G fuse links. Depending on the application and method of installation, the heat rise conditions in closed fuse holders must be tested. Higher ambient temperatures represent an additional load for the fuse links. A shift in rated current should therefore be taken into account in such applications. When selecting G fuse links, make sure that they do not exceed the specified maximum power loss. For specification details, contact the fuse manufacturer.

# 8WH2 Spring-Loaded Terminals

## 8WH fuse terminals

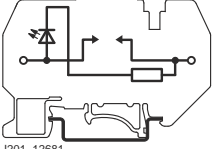
4

### Selection and ordering data

	Version	Order No.	MOQ*	
<b>Terminal size 4 mm<sup>2</sup></b>				
 <p>8WH2 000-1AG08</p>  <p>8WH2 000-1BG28</p>  <p>1201_12681 8WH2 000-1BG28</p>	<p><b>Fuse terminals, terminal size 4 mm<sup>2</sup>, for blade-type fuses acc. to ISO/DIS8820/DIN72581-3</b></p> <ul style="list-style-type: none"> <li>Terminal width 8.2 mm</li> <li>• <b>CUL</b>s</li> <li>• Connection data <ul style="list-style-type: none"> <li>- Rigid 0.08 ... 6 mm<sup>2</sup></li> <li>- Flexible 0.08 ... 4 mm<sup>2</sup></li> <li>- AWG 28-10</li> <li>- <math>I = 30</math> A</li> <li>- <math>U = 400</math> V</li> </ul> </li> <li>• Enclosed at both ends</li> </ul> <p><b>Versions</b></p> <ul style="list-style-type: none"> <li>• Without LED display</li> <li>• LED display 12 V</li> <li>• LED display 24 V</li> </ul>	<p><b>8WH2 000-1AG08</b></p> <p><b>8WH2 000-1BG28</b></p> <p><b>8WH2 000-1BG38</b></p>	<p>50 units</p> <p>50 units</p> <p>50 units</p>	
	 <p>8WH2 000-1GG08</p>  <p>8WH2 000-1JG38</p>	<p><b>Fuse terminals, terminal size 4 mm<sup>2</sup>, for 5 x 20 mm G fuse links</b></p> <ul style="list-style-type: none"> <li>Terminal width 6.2 mm</li> <li>• <b>CUL</b>s</li> <li>• IEC 60947-7-3</li> <li>• With fuse <ul style="list-style-type: none"> <li>- Rigid 0.08 ... 6 mm<sup>2</sup>, flexible 0.08 ... 4 mm<sup>2</sup>, AWG 28-10</li> <li>- <math>I_{max} = 6.3</math> A, only short-circuit protection, single 4 W, group 2.5 W</li> <li>- <math>U = 250</math> V, overload protection, single 4 W, group 1.6 W</li> </ul> </li> <li>• As isolating terminal <ul style="list-style-type: none"> <li>- Rigid 0.08 ... 6 mm<sup>2</sup>, flexible 0.08 ... 4 mm<sup>2</sup>, AWG 28-10</li> <li>- <math>I = 6.3</math> A, <math>U = 250</math> V</li> </ul> </li> <li>• Enclosed at both ends</li> </ul> <p><b>Versions</b></p> <ul style="list-style-type: none"> <li>• Without LED display</li> <li>• LED display 15 to 30 V</li> <li>• LED display 30 to 60 V</li> <li>• LED display 110 to 250 V</li> </ul>	<p><b>8WH2 000-1GG08</b></p> <p><b>8WH2 000-1JG38</b></p> <p><b>8WH2 000-1JG68</b></p> <p><b>8WH2 000-1MG08</b></p>	<p>50 units</p> <p>50 units</p> <p>50 units</p> <p>50 units</p>
		 <p>8WH2 000-1HG08</p>	<p><b>Fuse terminals, terminal size 4 mm<sup>2</sup>, for G fuse links 6.3 x 32 mm (inch fuses)</b></p> <ul style="list-style-type: none"> <li>Terminal width 8.2 mm</li> <li>• <b>CUL</b>s</li> <li>• IEC 60947-7-3</li> <li>• With fuse <ul style="list-style-type: none"> <li>- Rigid 0.08 ... 6 mm<sup>2</sup>, flexible 0.08 ... 4 mm<sup>2</sup>, AWG 28-10</li> <li>- <math>I = 10</math> A,</li> <li>- <math>U = 400</math> V</li> <li>- Current and voltage are determined by the fitted fuse or the selected LED display</li> </ul> </li> <li>• As isolating terminal <ul style="list-style-type: none"> <li>- Rigid 0.08 ... 6 mm<sup>2</sup>, flexible 0.08 ... 4 mm<sup>2</sup>, AWG 28-10</li> <li>- <math>I = 10</math> A, <math>U = 400</math> V</li> </ul> </li> <li>• Enclosed at both ends</li> </ul> <p><b>Versions</b></p> <ul style="list-style-type: none"> <li>• Without LED display</li> <li>• With LED display 100 V to 250 V</li> </ul>	<p><b>8WH2 000-1HG08</b></p> <p><b>8WH2 000-1RG08</b></p>
<b>Accessories</b>				
 <p>8WH9 070-0AA00</p>	<p><b>Compartment partitions, for terminal sizes 1.5 and 4 mm<sup>2</sup></b></p> <p><b>Versions</b></p> <ul style="list-style-type: none"> <li>• Two clamping points</li> <li>• Three clamping points (inch fuse)</li> </ul>	<p><b>8WH9 070-0AA00</b></p> <p><b>8WH9 070-0KA00</b></p>	<p>50 units</p> <p>50 units</p>	

Note:

For general accessories for 8WH terminal blocks, [see chapter 8](#).

### Overview



Through-type terminals with isolating blade capability are the most commonly used terminal types in measuring and control technology.

The isolating blade terminals with nominal cross-section of 2.5 mm<sup>2</sup> are characterized in particular by their slim design of 5.2 mm and their high current-carrying capacity of 16 A. In addition the terminals provide a test tap parallel to the isolation point for 2.3 mm  $\varnothing$  test plugs. Potential distributors can be conveniently assembled using connecting combs.

Terminals with three and four clamping points are available for multi-conductor connection. With their compact design these terminals can also be used in small terminal boxes and their front connection arrangement enables user-friendly wiring.

The isolating blade is secured to the terminal so that it cannot be lost.

A label can be snapped on to the middle of the terminal at the front. Further labels can also be mounted flat on the side of the terminals.

### Technical specifications









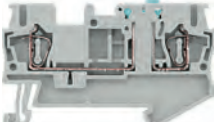

	8WH2 000-6CF00	8WH2 500-6CF00	8WH2 003-6CF00	8WH2 004-6CF00	8WH2 000-6CG00
Dimensions					
• Width/length/cover width in mm	5.2 / 60.5 / 2.2	5.2 / 51 / 2.2	5.2 / 72 / 2.2	5.2 / 84 / 2.2	6.2 / 61.5 / --
• Height (NS 35/7.5 / NS 35/15) in mm	36.5 / 44	43 / 50.5	36.5 / 44		
Technical specifications acc. to IEC/DIN VDE					
• Max. load current in A / cross-section in mm <sup>2</sup>	16 / 4				16 / 6
• Maximum data // rated data in A / mm <sup>2</sup>	--				
• Rated impulse withstand voltage in kV / pollution degree	6 / 3				
• Overvoltage category / molded plastic group	III / I				
Connection capacities					
• Flexible with end sleeve, with plastic sleeve in mm <sup>2</sup>	0.25... 2.5				0.25 ... 4
• Flexible with end sleeve, without plastic sleeve in mm <sup>2</sup>	0.25 ... 2.5				0.25 ... 4
• Flexible with two-wire connection end sleeve, with plastic sleeve in mm <sup>2</sup>	0.5				
Stripped length in mm	10				
Plug gauge (IEC 60947-1)	A4	A3	A4	A3	
Molded plastic type	PA				
• Flammability class acc. to UL 94	V0				
Approval data (UL/cUL and CSA)					
• Rated voltage / rated current / conductor sizes					
- UL/cUL: in V/A / AWG	600 / 16 / 26-12	600 / 16 / 24-12	600 / 16 / 26-12		300 / 6.3 / 24-10
- CSA: in V/A / AWG	--				

# 8WH2 Spring-Loaded Terminals

## 8WH isolating blade terminals

4

### Selection and ordering data

	Version	Order No.	MOQ*
<b>Terminal size 2.5 mm<sup>2</sup></b>			
 <p>8WH2 000-6CF00</p>  <p>I201_12684 8WH2 000-6CF00</p>	<p><b>Isolating blade terminals, terminal size 2.5 mm<sup>2</sup></b></p> <ul style="list-style-type: none"> <li>Terminal width 5.2 mm</li> <li>UL US</li> <li>IEC 60947-7-1                             <ul style="list-style-type: none"> <li>Rigid 0.08 ... 4 mm<sup>2</sup></li> <li>Flexible 0.08 ... 2.5 mm<sup>2</sup></li> <li>AWG 28-12</li> <li>I = 16 A</li> <li>U = 400 V</li> </ul> </li> <li>For 3 and 4 clamping points:                             <ul style="list-style-type: none"> <li>Rigid 0.14 ... 4 mm<sup>2</sup></li> <li>Flexible 0.14 ... 2.5 mm<sup>2</sup></li> <li>AWG 26-14</li> </ul> </li> </ul> <p><b>Versions</b></p> <ul style="list-style-type: none"> <li>Gray                             <ul style="list-style-type: none"> <li>Two clamping points</li> <li>Three clamping points</li> <li>Four clamping points</li> </ul> </li> </ul> <p><b>Note</b></p> <p>On terminals with three and four clamping points, the total current through all connected conductors must not exceed the max. load current.</p>	<p><b>8WH2 000-6CF00</b></p> <p><b>8WH2 003-6CF00</b></p> <p><b>8WH2 004-6CF00</b></p>	<p>50 units</p> <p>50 units</p> <p>50 units</p>
 <p>8WH2 003-6CF00</p>  <p>I201_12685 8WH2 003-6CF00</p>			
 <p>8WH2 004-6CF00</p>  <p>I201_12686 8WH2 004-6CF00</p>			
 <p>8WH2 000-6CG00</p>	<p><b>Isolating blade terminals, size 4mm<sup>2</sup>, two clamping points</b></p> <ul style="list-style-type: none"> <li>Gray</li> <li>Terminal width 6.2 mm</li> <li>UL US</li> <li>IEC 60947-7-1                             <ul style="list-style-type: none"> <li>Rigid 0.08 ... 6 mm<sup>2</sup>, flexible 0.08 ... 4 mm<sup>2</sup>, AWG 28-10</li> <li>I = 16 A, U = 400 V</li> </ul> </li> <li>Enclosed at both ends</li> </ul>	<b>8WH2 000-6CG00</b>	50 units
<b>Accessories</b>			
 <p>8WH9 070-0AA00</p>	<p><b>Compartment partitions, for terminal size 1.5 to 4 mm<sup>2</sup></b></p> <p><b>Versions</b></p> <ul style="list-style-type: none"> <li>Two clamping points</li> <li>Three clamping points</li> <li>Four clamping points</li> </ul>	<p><b>8WH9 070-0AA00</b></p> <p><b>8WH9 070-0GA00</b></p> <p><b>8WH9 070-0HA00</b></p>	<p>50 units</p> <p>50 units</p> <p>50 units</p>
 <p>88WH9 000-2GA00</p>	<p><b>Covers, for terminal sizes 1.5 ... 2.5 mm<sup>2</sup></b></p> <p><b>Versions</b></p> <ul style="list-style-type: none"> <li>For two clamping points</li> <li>For three clamping points</li> <li>For four clamping points</li> </ul>	<p><b>8WH9 000-2GA00</b></p> <p><b>8WH9 000-4GA00</b></p> <p><b>8WH9 000-5GA00</b></p>	<p>50 units</p> <p>50 units</p> <p>50 units</p>
 <p>8WH9 000-0GA00</p>	<p><b>Cover segments, for terminal size 2.5 mm<sup>2</sup> and three or four clamping points</b></p>	<b>8WH9 000-0GA00</b>	10 units

Note:

For general accessories for 8WH terminal blocks, see chapter 8.

### Overview

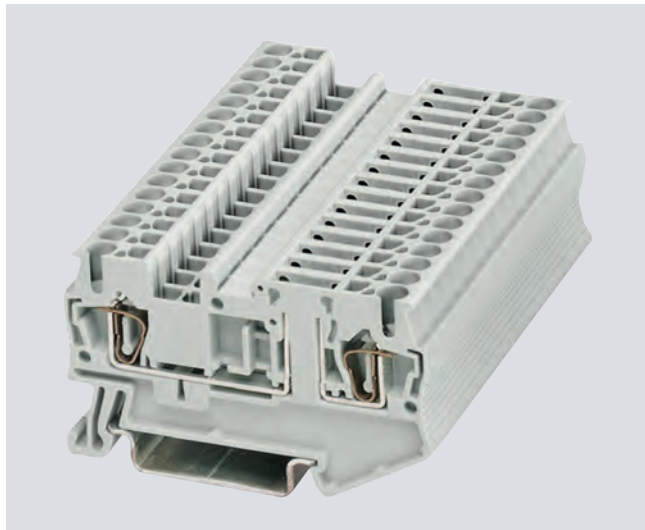

The isolating terminals are available with the same contour as the isolating blade terminals. The terminals excel with their narrow width of only 5.2 mm and their high current load rating of 16 A.

There is a test option for 2.3 mm  $\varnothing$  test plugs at both ends of the isolating point.

The 6.2 mm wide isolating terminal with terminal size 4 mm<sup>2</sup> is a base terminal for accommodating:

- Isolating plugs
- Through-type connectors
- Fused connectors
- Component connectors

A label can be snapped on to the middle of the terminal at the front. Further labels can also be mounted flat on the side of the terminals.

### Technical specifications







	8WH2 000-6AF00	8WH2 500-6AF00	8WH2 003-6AF00	8WH2 004-6AF00	8WH2 000-6AG00
Dimensions					
• Width/length/cover width in mm	5.2 / 60.5 / 2.2	5.2 / 51 / 2.2	5.2 / 72 / 2.2	5.5 / 84 / 2.2	6.2 / 61.5 / --
• Height (NS 35/7.5 / NS 35/15) in mm	36.5 / 44	43 / 50.5	36.5 / 44		
Technical specifications acc. to IEC/DIN VDE					
• Max. load current in A / cross-section in mm <sup>2</sup>	16 / 4				16 / 6
• Rated impulse withstand voltage in kV / pollution degree	6 / 3				
• Overvoltage category / molded plastic group	III / I				
Connection capacities					
• Flexible with end sleeve, with plastic sleeve in mm <sup>2</sup>	0.25 ... 2.5				0.25 ... 4
• Flexible with end sleeve, without plastic sleeve in mm <sup>2</sup>	0.25 ... 2.5				0.25 ... 4
• Flexible with two-wire connection end sleeve, with plastic sleeve in mm <sup>2</sup>	0.5				
Stripped length in mm	10				
Plug gauge (IEC 60947-1)	A3				A4
Molded plastic type	PA				
• Flammability class acc. to UL 94	V0				
Approval data (UL/cUL and CSA)					
• Rated voltage / rated current / conductor sizes					
- UL/cUL: in V/A / AWG	300 / 16 / 26-12	300 / 16 / 24-12	300 / 16 / 26-12		300 / 6.3 / 24-10
- CSA: in V/A / AWG	--				

# 8WH2 Spring-Loaded Terminals

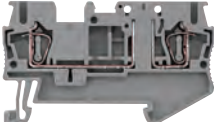
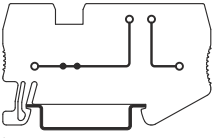
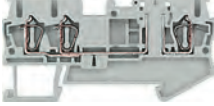
## 8WH isolating terminals

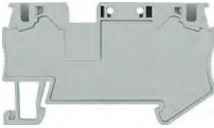
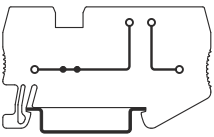
4

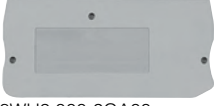
### Selection and ordering data

Version	Order No.	MOQ*	
<b>Terminal size 2.5 mm<sup>2</sup></b>			
 <p>8WH2 000-6AF00</p>  <p>I201_12682 8WH2 000-6AF00</p>  <p>8WH2 003-6AF00</p>  <p>8WH2 004-6AF00</p>	<p><b>Isolating terminals, terminal size 2.5 mm<sup>2</sup></b></p> <ul style="list-style-type: none"> <li>• Gray</li> <li>• Terminal width 5.2 mm</li> <li>• <b>C<sub>UL</sub>us</b></li> <li>• IEC 60947-7-1 <ul style="list-style-type: none"> <li>- Rigid 0.08 ... 4 mm<sup>2</sup></li> <li>- Flexible 0.08 ... 2.5 mm<sup>2</sup></li> <li>- AWG 28-12</li> </ul> </li> <li>- Current and voltage are determined by the fitted plug</li> <li>- <math>I = 16</math> A</li> <li>- <math>U = 400</math> V</li> </ul> <p><b>Versions</b></p> <ul style="list-style-type: none"> <li>• Two clamping points</li> <li>• Three clamping points</li> <li>• Four clamping points</li> </ul>	<p><b>8WH2 000-6AF00</b></p> <p><b>8WH2 003-6AF00</b></p> <p><b>8WH2 004-6AF00</b></p>	<p>50 units</p> <p>50 units</p> <p>50 units</p>
<b>Terminal size 4 mm<sup>2</sup></b>			
 <p>8WH2 000-6AG00</p>  <p>I201_12682 8WH2 000-6AG00</p>	<p><b>Isolating terminals, terminal size 4 mm<sup>2</sup>, two clamping points</b></p> <ul style="list-style-type: none"> <li>• Gray</li> <li>• Terminal width 6.2 mm</li> <li>• <b>C<sub>UL</sub>us</b></li> <li>• IEC 60947-7-1 <ul style="list-style-type: none"> <li>- Rigid 0.08 ... 6 mm<sup>2</sup></li> <li>- Flexible 0.08 ... 4 mm<sup>2</sup></li> <li>- AWG 28-10</li> </ul> </li> <li>- Current and voltage are determined by the fitted plug</li> <li>- <math>I = 16</math> A</li> <li>- <math>U = 400</math> V</li> <li>• Enclosed at both ends</li> </ul>	<p><b>8WH2 000-6AG00</b></p>	<p>50 units</p>
<b>Accessories</b>			
 <p>8WH9 070-0GA00</p>	<p><b>Compartment partitions</b></p> <p><b>Versions</b></p> <ul style="list-style-type: none"> <li>• For terminal size 2.5 mm<sup>2</sup> <ul style="list-style-type: none"> <li>- For three clamping points</li> <li>- For four clamping points</li> </ul> </li> <li>• For terminal size 4 mm<sup>2</sup> <ul style="list-style-type: none"> <li>- For two clamping points</li> </ul> </li> </ul>	<p><b>8WH9 070-0GA00</b></p> <p><b>8WH9 070-0HA00</b></p> <p><b>8WH9 070-0AA00</b></p>	<p>50 units</p> <p>50 units</p> <p>50 units</p>
 <p>8WH9 000-2GA00</p>	<p><b>Covers</b></p> <p>Gray</p> <p><b>Versions</b></p> <ul style="list-style-type: none"> <li>• For terminal size 1.5 ... 2.5 mm<sup>2</sup> and two clamping points</li> <li>• For terminal size 2.5 mm<sup>2</sup> and three clamping points</li> <li>• For terminal size 2.5 mm<sup>2</sup> and four clamping points</li> </ul>	<p><b>8WH9 000-2GA00</b></p> <p><b>8WH9 000-4GA00</b></p> <p><b>8WH9 000-5GA00</b></p>	<p>50 units</p> <p>50 units</p> <p>50 units</p>
 <p>8WH9 000-0GA00</p>	<p><b>Cover segments, for terminal size 1.5 mm<sup>2</sup> and 2.5 mm<sup>2</sup> and three or four clamping points</b></p> <p>Gray</p>	<p><b>8WH9 000-0GA00</b></p>	<p>10 units</p>

Note:

For general accessories for 8WH terminal blocks, [see chapter 8](#).

### Overview

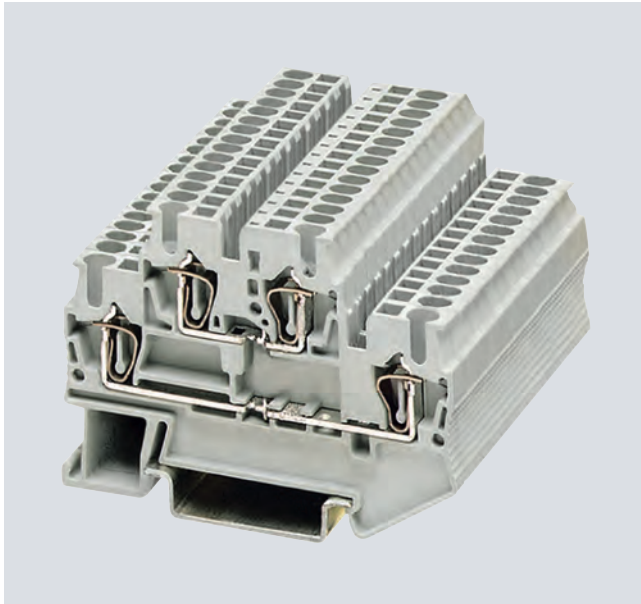

#### Standard two-tier terminals

With the two voltage levels routed through two separate tiers, the two-tier terminals require 50% less space than equivalent single-tier terminals. To implement a wide range of wiring tasks, connecting combs can be fitted to both tiers of the spring-loaded terminal series. Facilities for inscription are provided at each clamping point.

#### PE/ground conductor function

Perfect mechanical and electrical contact with the support rail is provided by simply snapping the terminals onto the rail.

The PE two-tier terminals meet all the requirements of IEC 60947-7-2:

- Low contact resistance
- Stainless clamping points
- Green-yellow enclosure
- Additional inscription options.

#### PE/L and PE/N types

The PE/L and PE/N types provide a PE/ground contact to the support rail in the lower tier. The upper tier is designed as a through-type tier. Color coding of the PE and neutral tiers enables clear and unambiguous distribution of the potential.

The clamping points of two-tier terminals can be inscribed with flat labels.

### Technical specifications

	8WH2 020-0AE00 8WH2 020-0AE01 8WH2 025-0AE00	8WH0 020-0CE07	8WH2 020-0AF00 8WH2 020-0AF01 8WH2 025-0AF00	8WH2 023-0AF00 8WH2 023-0AF01 8WH2 022-0AF00	8WH2 020-0CF07
Dimensions					
• Width/length/cover width in mm	4.2 / 67.5 / 2.2		5.2 / 67.5 / 2.2	5.2 / 91.5 / 2.2	5.2 / 67.5 / 2.2
• Height (NS 35/7.5 / NS 35/15) in mm	47.5 / 55				
Technical specifications acc. to IEC/DIN VDE					
• Max. load current in A / cross-section in mm <sup>2</sup>	17.5 / 1.5	--	26 / 4	--	--
• Maximum data / rated data in A / mm <sup>2</sup>	--			26 / 4 // 22 / 2.5	--
• Rated impulse withstand voltage in kV / pollution degree	6 / 3				
• Overvoltage category / molded plastic group	III / I				
Connection capacities					
• Flexible with end sleeve, with plastic sleeve in mm <sup>2</sup>	0.25 ... 1.5		0.25 ... 2.5		
• Flexible with end sleeve, without plastic sleeve in mm <sup>2</sup>	0.25 ... 1.5		0.25 ... 2.5		
• Flexible with two-wire connection end sleeve, with plastic sleeve in mm <sup>2</sup>	0.5				
Stripped length in mm	10				
Plug gauge (IEC 60947-1)	A1		A3		
Molded plastic type	PA				
• Flammability class acc. to UL 94	V0				
Approval data (UL/cUL and CSA)					
• Rated voltage / rated current / conductor sizes					
- UL/cUL: in V/A / AWG	300 / 15 / 26-14	-- / -- / 26-14	600 / 20 / 26-12	300 / 20 / 26-12	-- / -- / 26-12
- CSA: in V/A / AWG	300 / 15 / 26-14	-- / -- / 26-14	--		-- / -- / 26-12
Support rails/protective conductor busbars	--	See section "Support rails" on page 1/3	--		See section "Support rails" on page 1/3

# 8WH2 Spring-Loaded Terminals

## 8WH two-tier terminals

4

	8WH2 023-0CF07	8WH2 020-4AF00	8WH2 020-4BF00
Dimensions			
• Width/length/cover width in mm	5.2 / 91.5 / 2.2	5.2 / 67.5 / 2.2	
• Height (NS 35/7.5 / NS 35/15) in mm	47.5 / 55		
Technical specifications acc. to IEC/DIN VDE			
• Max. load current in A / cross-section in mm <sup>2</sup>	--	32 / 4	
• Rated impulse withstand voltage in kV / pollution degree	6 / 3		
• Overvoltage category / molded plastic group	III / I		
Connection capacities			
• Flexible with end sleeve, with plastic sleeve in mm <sup>2</sup>	0.25 ... 2.5		
• Flexible with end sleeve, without plastic sleeve in mm <sup>2</sup>	0.25 ... 2.5		
• Flexible with two-wire connection end sleeve, with plastic sleeve in mm <sup>2</sup>	0.5		
Stripped length in mm	10		
Plug gauge (IEC 60947-1)	A3		
Molded plastic type	PA		
• Flammability class acc. to UL 94	V0		
Approval data (UL/cUL and CSA)			
• Rated voltage / rated current / conductor sizes			
- UL/cUL: in V/A / AWG	-- / -- / 26-12	300 / 20 / 26-12	--
- CSA: in V/A / AWG	-- / -- / 26-12	--	
Support rails/protective conductor busbars	See section "Support rails" on page 1/3	--	

	8WH2 020-4CF00	8WH2 020-0AG00 8WH2 020-0AG01 8WH2 025-0AG00	8WH2 020-0CG07
Dimensions			
• Width/length/cover width in mm	5.2 / 67.5 / 2.2	6.2 / 83.5 / 2.2	6.2 / 83.5 / 2.2
• Height (NS 35/7.5 / NS 35/15) in mm	47.5 / 55		
Technical specifications acc. to IEC/DIN VDE			
• Max. load current in A / cross-section in mm <sup>2</sup>	26 / 4	32 / 6	--
• Rated impulse withstand voltage in kV / pollution degree	6 / 3		
• Overvoltage category / molded plastic group	III / I		
Connection capacities			
• Flexible with end sleeve, with plastic sleeve in mm <sup>2</sup>	0.25 ... 2.5	0.25 ... 4	0.25 ... 4
• Flexible with end sleeve, without plastic sleeve in mm <sup>2</sup>	0.25 ... 2.5	0.25 ... 4	0.25 ... 4
• Flexible with two-wire connection end sleeve, with plastic sleeve in mm <sup>2</sup>	0.5	0.5 ... 1	0.5 ... 1
Stripped length in mm	10		
Plug gauge (IEC 60947-1)	A3	A4	
Molded plastic type	PA		
• Flammability class acc. to UL 94	V0		
Approval data (UL/cUL and CSA)			
• Rated voltage / rated current / conductor sizes			
- UL/cUL: in AWG	300 / 20 / 26-12	300 / 30 / 20-10	20-10
- CSA: in AWG	-- / -- / 26-12		20-10
Support rails/protective conductor busbars	--		See section "Support rails" on page 1/3

### Selection and ordering data

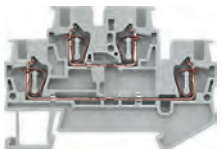
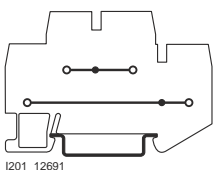
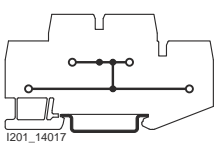
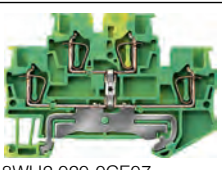
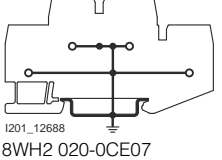
Version	Order No.	MOQ*
<b>Terminal size 1.5 mm<sup>2</sup></b>		
 <p>8WH2 020-0AE00</p>  <p>1201_12691 8WH2 020-0AE00</p>  <p>1201_14017 8WH2 025-0AE00</p>	<p><b>Two-tier terminals, terminal size 1.5 mm<sup>2</sup></b></p> <ul style="list-style-type: none"> <li>Terminal width 4.2 mm</li> <li>UL US, C</li> <li>IEC 60947-7-1                     <ul style="list-style-type: none"> <li>Rigid 0.08 ... 1.5 mm<sup>2</sup></li> <li>Flexible 0.08 ... 1.5 mm<sup>2</sup></li> <li>AWG 28-16</li> <li>I = 17.5 A</li> </ul> </li> <li>The total current through all connected conductors must not exceed the max. load current</li> <li>U = 500 V</li> </ul> <p><b>Versions</b></p> <ul style="list-style-type: none"> <li>Gray                     <ul style="list-style-type: none"> <li>Without equipotential bonding, 2-pole Ⓢ</li> <li>With equipotential bonding, 1-pole</li> </ul> </li> <li>Blue, 2-pole</li> </ul>	<p><b>8WH2 020-0AE00</b> 50 units  <b>8WH2 025-0AE00</b> 50 units  <b>8WH2 020-0AE01</b> 50 units</p>
 <p>8WH2 020-0CE07</p>  <p>1201_12688 8WH2 020-0CE07</p>	<p><b>PE two-tier terminals, terminal size 1.5 mm<sup>2</sup></b></p> <ul style="list-style-type: none"> <li>Terminal width 4.2 mm</li> <li>UL US, C</li> <li>IEC 60947-7-1                     <ul style="list-style-type: none"> <li>Rigid 0.08 ... 1.5 mm<sup>2</sup></li> <li>Flexible 0.08 ... 1.5 mm<sup>2</sup></li> <li>AWG 28-16</li> </ul> </li> <li>Green/yellow</li> </ul>	<p><b>8WH2 020-0CE07</b> 50 units</p>

\* You can order this quantity or a multiple thereof.

# 8WH2 Spring-Loaded Terminals

## 8WH two-tier terminals

4

### Terminal size 2.5 mm<sup>2</sup>

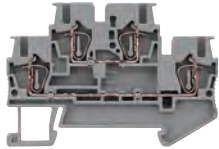

8WH2 020-0AF00

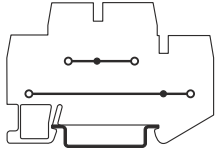

1201\_12691  
8WH2 020-0AF00

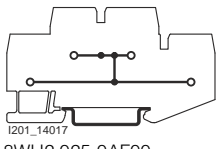

1201\_14017  
8WH2 025-0AF00

#### Two-tier terminals, terminal size 2.5 mm<sup>2</sup>

- Terminal width 5.2 mm
- US
- IEC 60947-7-1
  - Rigid 0.08 ... 4 mm<sup>2</sup>
  - Flexible 0.08 ... 2.5 mm<sup>2</sup>
  - AWG 28-12
  - I = 26 A
  - The total current through all connected conductors must not exceed the max. load current
  - U = 500 V

#### Versions

- Gray
  - Without equipotential bonding, 2-pole
  - With equipotential bonding, 1-pole
- Blue
  - Without equipotential bonding, 2-pole
  - With equipotential bonding, 1-pole

Version	Order No.	MOQ*
---------	-----------	------

8WH2 020-0AF00	50 units
8WH2 025-0AF00	50 units
8WH2 020-0AF01	50 units
8WH2 025-0AF01	50 units

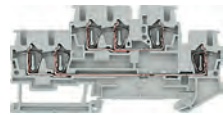

8WH2 023-0AF00

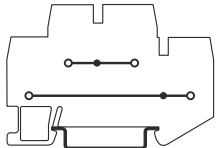

1201\_12691  
8WH2 023-0AF00

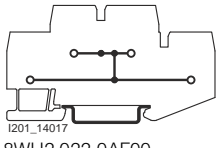

1201\_14017  
8WH2 022-0AF00

#### Two-tier terminals, terminal size 2.5 mm<sup>2</sup>, three clamping points on one level

- Terminal width 5.2 mm
- US
- IEC 60947-7-1
  - Rigid 0.08 ... 4 mm<sup>2</sup>
  - Flexible 0.08 ... 2.5 mm<sup>2</sup>
  - AWG 28-12
  - I = 26 A
  - The total current through all connected conductors must not exceed the max. load current
  - U = 500 V

#### Versions

- Gray
  - Without equipotential bonding, 2-pole
  - With equipotential bonding, 1-pole
- Blue, 2-pole

8WH2 023-0AF00	50 units
8WH2 022-0AF00	50 units
8WH2 023-0AF01	50 units

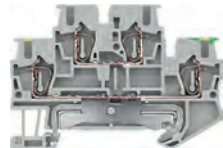

8WH2 020-4AF00

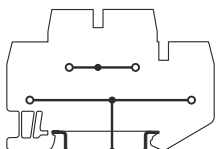

1201\_12689  
8WH2 020-4AF00







#### Two-tier terminals, terminal size 2.5 mm<sup>2</sup>, L at top and PE at bottom

- Gray
- Terminal width 5.2 mm
- US
- DIN VDE 0611 and IEC 60947-7-2
  - Rigid 0.08 ... 4 mm<sup>2</sup>
  - Flexible 0.08 ... 2.5 mm<sup>2</sup>
  - AWG 28-12
  - I = 32 A
  - U = 500 V

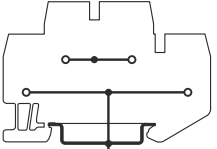
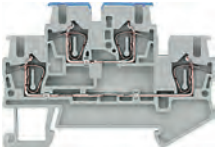
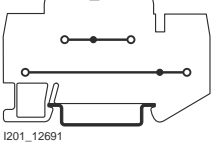
8WH2 020-4AF00	50 units
----------------	----------

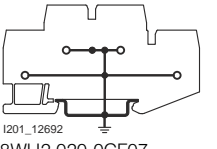
# 8WH2 Spring-Loaded Terminals

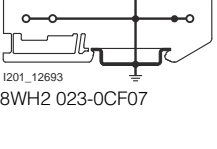
## 8WH two-tier terminals





Version	Order No.	MOQ*
 <p>8WH2 020-4BF00</p>  <p>I201_12690 8WH2 020-4BF00</p> <p><b>Two-tier terminals, terminal size 2.5 mm<sup>2</sup>, N at top and PE at bottom</b></p> <ul style="list-style-type: none"> <li>• Gray</li> <li>• Terminal width 5.2 mm</li> <li>• DIN VDE 0611 and IEC 60947-7-2               <ul style="list-style-type: none"> <li>- Rigid 0.08 ... 4 mm<sup>2</sup></li> <li>- Flexible 0.08 ... 2.5 mm<sup>2</sup></li> <li>- AWG 28-12</li> <li>- I = 32 A</li> <li>- U = 500 V</li> </ul> </li> </ul>	8WH2 020-4BF00	50 units
 <p>8WH2 020-4CF00</p>  <p>I201_12691 8WH2 020-4CF00</p> <p><b>Two-tier terminals, terminal size 2.5 mm<sup>2</sup>, N at top and L at bottom</b></p> <ul style="list-style-type: none"> <li>• Gray</li> <li>• Terminal width 5.2 mm</li> <li>•  <b>UL</b></li> <li>• IEC 60947-7-1               <ul style="list-style-type: none"> <li>- Rigid 0.08 ... 4 mm<sup>2</sup></li> <li>- Flexible 0.08 ... 2.5 mm<sup>2</sup></li> <li>- AWG 28-12</li> <li>- I = 26 A</li> <li>- U = 500 V</li> </ul> </li> </ul>	8WH2 020-4CF00	50 units
 <p>8WH2 020-0CF07</p>  <p>I201_12692 8WH2 020-0CF07</p> <p><b>PE two-tier terminals, terminal size 2.5 mm<sup>2</sup>, two clamping points on one level</b></p> <ul style="list-style-type: none"> <li>• Terminal width 5.2 mm</li> <li>•  <b>UL</b></li> <li>• IEC 60947-7-2               <ul style="list-style-type: none"> <li>- Rigid 0.08 ... 4 mm<sup>2</sup></li> <li>- Flexible 0.08 ... 2.5 mm<sup>2</sup></li> <li>- AWG 28-12</li> </ul> </li> <li>• Green/yellow</li> </ul>	8WH2 020-0CF07	50 units
 <p>8WH2 023-0CF07</p>  <p>I201_12693 8WH2 023-0CF07</p> <p><b>PE two-tier terminals, terminal size 2.5 mm<sup>2</sup>, three clamping points on one level</b></p> <ul style="list-style-type: none"> <li>• Terminal width 5.2 mm</li> <li>•  <b>UL</b></li> <li>• IEC 60947-7-2               <ul style="list-style-type: none"> <li>- Rigid 0.08 ... 4 mm<sup>2</sup></li> <li>- Flexible 0.08 ... 2.5 mm<sup>2</sup></li> <li>- AWG 28-12</li> </ul> </li> <li>• Green/yellow</li> </ul>	8WH2 023-0CF07	50 units

\* You can order this quantity or a multiple thereof.

# 8WH2 Spring-Loaded Terminals

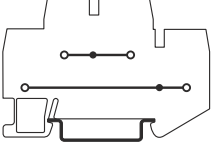
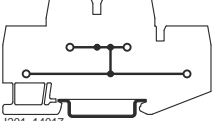
## 8WH two-tier terminals

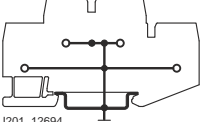
4

	Version	Order No.	MOQ*
<b>Terminal size 4 mm<sup>2</sup></b>			
 <p>8WH2 020-0AG00</p>	<p><b>Two-tier terminals, terminal size 4 mm<sup>2</sup></b></p> <ul style="list-style-type: none"> <li>Terminal width 6.2 mm</li> <li>• <b>UL</b></li> <li>• <b>IEC 60947-7-1</b> <ul style="list-style-type: none"> <li>- Rigid 0.08 ... 6 mm<sup>2</sup></li> <li>- Flexible 0.08 ... 4 mm<sup>2</sup></li> <li>- AWG 28-10</li> <li>- <math>I = 32</math> A</li> <li>- The total current through all connected conductors must not exceed the max. load current</li> <li>- <math>U = 500</math> V</li> </ul> </li> </ul>	<p><b>8WH2 020-0AG00</b>  <b>8WH2 025-0AG00</b>  <b>8WH2 020-0AG01</b></p>	<p>50 units                      50 units                      50 units</p>
 <p>1201_12691                      8WH2 020-0AG00</p>	<p><b>Versions</b></p> <ul style="list-style-type: none"> <li>• Gray                             <ul style="list-style-type: none"> <li>- Without equipotential bonding, 2-pole</li> <li>- With equipotential bonding, 1-pole</li> </ul> </li> <li>• Blue, 2-pole</li> </ul>		
 <p>1201_14017                      8WH2 025-0AG00</p>			
 <p>8WH2 020-0CG07</p>	<p><b>PE two-tier terminals, terminal size 4 mm<sup>2</sup></b></p> <ul style="list-style-type: none"> <li>Terminal width 6.2 mm</li> <li>• <b>UL</b></li> <li>• <b>IEC 60947-7-2</b> <ul style="list-style-type: none"> <li>- Rigid 0.08 ... 6 mm<sup>2</sup></li> <li>- Flexible 0.08 ... 4 mm<sup>2</sup></li> <li>- AWG 28-10</li> </ul> </li> <li>• Green/yellow</li> </ul>	<p><b>8WH2 020-0CG07</b></p>	<p>50 units</p>
 <p>1201_12694                      8WH2 020-0CG07</p>			
<b>Accessories</b>			
 <p>8WH9 070-0BA00</p>	<p><b>Compartment partitions, for terminal size 1.5 to 4 mm<sup>2</sup></b></p> <ul style="list-style-type: none"> <li>For visual and electrical separation of terminal groups</li> <li>• 2 mm thick</li> </ul>	<p><b>8WH9 070-0BA00</b></p>	<p>50 units</p>
 <p>8WH9 000-1VA00</p>	<p><b>Covers</b>                      Gray</p> <p><b>Versions</b></p> <ul style="list-style-type: none"> <li>• For terminal size 1.5 ... 2.5 mm<sup>2</sup></li> <li>• For terminal size 2.5 mm<sup>2</sup> and three clamping points</li> <li>• For terminal size 4 mm<sup>2</sup></li> </ul>	<p><b>8WH9 000-1VA00</b>  <b>8WH9 000-2VA00</b>  <b>8WH9 003-1VA00</b></p>	<p>50 units                      50 units                      50 units</p>

Note:

For general accessories for 8WH terminal blocks, [see chapter 8](#).

### Overview



Our three-tier terminals offer three feed-through levels in a slim 5.2 mm terminal enclosure. They enable high wiring density – ideal for switchboards where space is at a premium.

With one bridge shaft per tier, these terminal blocks are ideal for use as compact potential distributors or initiator terminals. All six clamping points are interconnected on the equipotential bonding versions.

The three-tier terminal range is rounded off with a PE terminal with the same contour.

### Inscription

Each tier of three-tier terminals can be inscribed with flat labels. If a label holder is used, the labels can be inserted at the front.

### Benefits

- Three feed-through levels with minimum footprint
- Comprehensive range of inscription options
- Matching accessories for 8WH terminal range
- One bridge shaft per tier
- Label holder is inserted.

### Technical specifications

	8WH2 030-0AF00 8WH2 030-0AF01 8WH2 035-0AF00	8WH2 035-0CF07	8WH2 030-4EF00 8WH2 030-4HF00
Dimensions			
• Width/length in mm	5.2 / 99.5	5.2 / 99.5	5.2 / 99.5
• Height (TS 35/7.5 / TS 35/15 / TS 32) in mm	58 / 65.5	58 / 65.5	58 / 65.5
Technical specifications acc. to IEC/DIN VDE			
• Max. load current in A / cross-section in mm <sup>2</sup>	28 / 4	--	28 / 4
• Rated impulse withstand voltage in kV / pollution degree	6 / 3	6 / 3	6 / 3
• Overvoltage category / molded plastic group	III / I	III / I	III / I
Connection capacities			
• Flexible with end sleeve without / with plastic sleeve in mm <sup>2</sup>	0.25 ... 2.5	0.25 ... 2.5	0.25 ... 2.5
• Flexible with end sleeve, without plastic sleeve in mm <sup>2</sup>	0.25 ... 2.5	0.25 ... 2.5	0.25 ... 2.5
• Flexible with TWIN end sleeve with plastic sleeve in mm <sup>2</sup>	0.5	0.5	0.5
Stripped length in mm	10	10	10
Plug gauge (IEC 60947-1)	A3	A3	A3
Molded plastic type	PA	PA	PA
• Flammability class acc. to UL 94	V0	V0	V0
Approval data (UL/CUR and CSA)			
• Rated voltage / rated current / conductor sizes			
- UL/CUR: V/A/AWG	600 / 20 / 26-12	-- / -- / 24-12	300 / 20 / 26-12
- CSA: V/A/AWG	--	--	--

### Selection and ordering data

Version	Order No.	MOQ*
---------	-----------	------

#### Terminal size 2.5 mm<sup>2</sup>

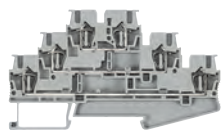

8WH2 030-0AF00

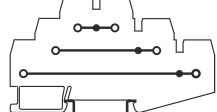

1201\_13974

8WH2 030-0AF00

#### Three-tier terminals, terminal size 2.5 mm<sup>2</sup>

- Enclosed at both ends
- Terminal width 5.2 mm
-  US
- IEC 60947-7-1
  - Rigid 0.08-4 mm<sup>2</sup>
  - Flexible 0.08-2.5 mm<sup>2</sup>
  - AWG 28-12
  - I = 28 A
  - U = 500 V

#### Versions

- Gray
- Blue



8WH2 030-0AF00  
8WH2 030-0AF01

50 units  
50 units

# 8WH2 Spring-Loaded Terminals

## 8WH three-tier terminals

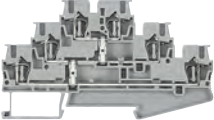
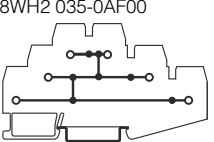
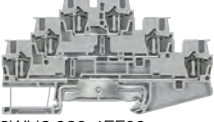
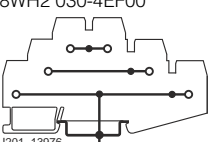
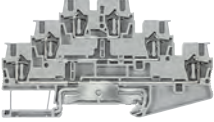
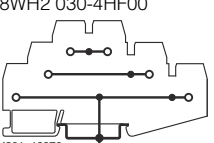
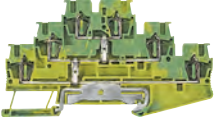
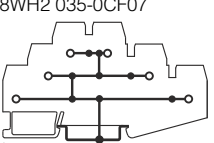
4

	Version	Order No.	MOQ*
 <p>8WH2 035-0AF00</p>  <p>1201_13975 8WH2 035-0AF00</p>	<p><b>Three-tier terminals, with equipotential bonding, terminal size 2.5 mm<sup>2</sup></b></p> <ul style="list-style-type: none"> <li>• Enclosed at both ends</li> <li>• Terminal width 5.2 mm</li> <li>• <b>C<sub>UL</sub>US</b></li> <li>• IEC 60947-7-1             <ul style="list-style-type: none"> <li>- Rigid 0.08-4 mm<sup>2</sup></li> <li>- Flexible 0.08-2.5 mm<sup>2</sup></li> <li>- AWG 28-12</li> <li>- I = 28 A</li> <li>- U = 500 V</li> </ul> </li> </ul> <p>Note</p> <p>The total current through all connected conductors must not exceed the max. load current.</p>	<p><b>8WH2 035-0AF00</b></p>	<p>50 units</p>
 <p>8WH2 030-4EF00</p>  <p>1201_13976 8WH2 030-4EF00</p>	<p><b>Three-tier terminals, "PE/LN", terminal size 2.5 mm<sup>2</sup></b></p> <ul style="list-style-type: none"> <li>• Enclosed at both ends</li> <li>• Terminal width 5.2 mm</li> <li>• <b>C<sub>UL</sub>US</b></li> <li>• IEC 60947-7-1 + IEC 60947-7-2             <ul style="list-style-type: none"> <li>- Rigid 0.08-4 mm<sup>2</sup></li> <li>- Flexible 0.08-2.5 mm<sup>2</sup></li> <li>- AWG 28-12</li> </ul> </li> </ul>	<p><b>8WH2 030-4EF00</b></p>	<p>50 units</p>
 <p>8WH2 030-4HF00</p>  <p>1201_13976 8WH2 030-4HF00</p>	<p><b>Three-tier terminals, "PE/LN", terminal size 2.5 mm<sup>2</sup></b></p> <ul style="list-style-type: none"> <li>• Enclosed at both ends</li> <li>• Terminal width 5.2 mm</li> <li>• <b>C<sub>UL</sub>US</b></li> <li>• IEC 60947-7-1 + IEC 60947-7-2             <ul style="list-style-type: none"> <li>- Rigid 0.08-4 mm<sup>2</sup></li> <li>- Flexible 0.08-2.5 mm<sup>2</sup></li> <li>- AWG 28-12</li> <li>- I = 28 A</li> <li>- U = 500 V</li> </ul> </li> </ul>	<p><b>8WH2 030-4HF00</b></p>	<p>50 units</p>
 <p>8WH2 035-0CF07</p>  <p>1201_13978 8WH2 035-0CF07</p>	<p><b>PE three-tier terminals, terminal size 2.5 mm<sup>2</sup></b></p> <ul style="list-style-type: none"> <li>• Enclosed at both ends</li> <li>• Terminal width 5.2 mm</li> <li>• <b>C<sub>UL</sub>US</b></li> <li>• IEC 60947-7-2             <ul style="list-style-type: none"> <li>- Rigid 0.08-4 mm<sup>2</sup></li> <li>- Flexible 0.08-2.5 mm<sup>2</sup></li> <li>- AWG 28-12</li> </ul> </li> </ul>	<p><b>8WH2 035-0CF07</b></p>	<p>50 units</p>
<p><b>Accessories</b></p>			
 <p>8WH9 000-1GD00</p>	<p><b>Covers for three-tier terminals</b></p>	<p><b>8WH9 000-1GD00</b></p>	<p>50 units</p>
 <p>8WH9 060-4BA00</p>	<p><b>Label holders, for three-tier terminals</b></p>	<p><b>8WH9 060-4BA00</b></p>	<p>100 units</p>

Note:

For general accessories for 8WH terminal blocks, [see chapter 8](#).

### Overview



#### Terminal size 2.5 mm<sup>2</sup>

The four-tier motor terminals with terminal size 2.5 mm<sup>2</sup> are ideal for the compact wiring of AC loads. They have three through-levels and one PE connection which is contacted by simply snapping it onto the mounting rail.

No cross-bridging option.

#### Terminal size 4 mm<sup>2</sup>

Like the 2.5 mm<sup>2</sup> version, the four-tier motor terminal with 4 mm<sup>2</sup> also allows the wiring of three phases and the PE in a single terminal. This terminal is enclosed at both ends.

No cross-bridging option.

#### Integrated PE/ground conductor function

PE contact with the support rail is made by simply snapping the terminal onto the rail. This makes the four-tier motor terminals with terminal size 4 mm<sup>2</sup> ideal for the space-saving wiring of AC motors.

#### Inscription

Each clamping point has a facility for inscription and a test option for 2.3 mm  $\varnothing$  test plugs.

There is also sufficient space to make large marking with labels in the middle of the terminal.

Labels can be mounted flat at the side of the terminals by simply snapping on

### Technical specifications







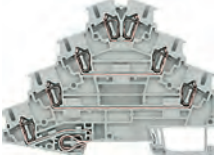
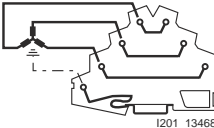

	8WH2 040-4LF00	8WH2 040-4LG00
Dimensions		
• Width/length/cover width in mm	5.2 / 98.5 / 2.2	6.2 / 101 / --
• Height (NS 35/7.5 / NS 35/15) in mm	73.5 / 81	83.5 / 91
Technical specifications acc. to IEC/DIN VDE		
• Max. load current in A / cross-section in mm <sup>2</sup>	26 / 4	32 / 6
• Rated impulse withstand voltage in kV / pollution degree	8 / 3	
• Overvoltage category / molded plastic group	III / I	
Connection capacities		
• Flexible with end sleeve, with plastic sleeve in mm <sup>2</sup>	0.25 ... 2.5	0.25 ... 4
• Flexible with end sleeve, without plastic sleeve in mm <sup>2</sup>	0.25 ... 2.5	0.25 ... 4
• Flexible with two-wire connection end sleeve, with plastic sleeve in mm <sup>2</sup>	--	0.5 ... 1
Stripped length in mm	10	
Plug gauge (IEC 60947-1)	A3	A4
Molded plastic type	PA	
• Flammability class acc. to UL 94	V0	
Approval data (UL/cUL and CSA)		
• Rated voltage / rated current / conductor sizes		
- UL/cUL: in V/A / AWG	-- / -- / 26-12	--
- CSA: in V/A / AWG	--	600 / 30 / 28-10

# 8WH2 Spring-Loaded Terminals

## 8WH four-tier motor terminals

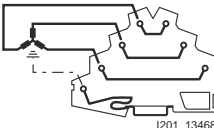
4

### Selection and ordering data

Version	Order No.	MOQ*
<b>Terminal size 2.5 mm<sup>2</sup></b>		
 <p>8WH2 040-4LF00</p>  <p>I201_13468</p> <p>8WH2 040-4LF00</p>	<p><b>Four-tier motor terminals, terminal size 2.5 mm<sup>2</sup></b></p> <ul style="list-style-type: none"> <li>Terminal width 5.2 mm</li> <li>  </li> <li>  </li> <li>IEC 60947-7-1 and IEC 60947-7-2                             <ul style="list-style-type: none"> <li>Rigid 0.08 ... 4 mm<sup>2</sup></li> <li>Flexible 0.08 ... 2.5 mm<sup>2</sup></li> <li>AWG 28-12</li> <li>I = 26 A</li> <li>U = 800 V</li> </ul> </li> </ul>	<p><b>8WH2 040-4LF00</b></p> <p>50 units</p>
<b>Terminal size 4 mm<sup>2</sup></b>		
 <p>8WH2 040-4LG00</p>  <p>I201_13468</p> <p>8WH2 040-4LG00</p>	<p><b>Four-tier motor terminals, terminal size 4 mm<sup>2</sup></b></p> <ul style="list-style-type: none"> <li>Terminal width 6.2 mm</li> <li>  </li> <li>  </li> <li>IEC 60947-7-1 and IEC 60947-7-2                             <ul style="list-style-type: none"> <li>Rigid 0.08 ... 6 mm<sup>2</sup></li> <li>Flexible 0.08 ... 4 mm<sup>2</sup></li> <li>AWG 28-10</li> <li>I = 32 A</li> <li>U = 800 V</li> </ul> </li> <li>Enclosed at both ends</li> </ul>	<p><b>8WH2 040-4LG00</b></p> <p>50 units</p>
<b>Accessories</b>		
 <p>8WH2 040-4LG00</p>	<p><b>Covers</b></p> <p><b>For four-tier motor terminals, terminal size 2.5 mm<sup>2</sup></b></p>	<p><b>8WH9 000-1GE00</b></p> <p>50 units</p>

Note:

For general accessories for 8WH terminal blocks, [see chapter 8](#).

\* You can order this quantity or a multiple thereof.

### Overview



Diode terminals with a nominal cross-section of 2.5 mm<sup>2</sup> and a mounting width of just 5.2 mm can be used to implement many different wiring tasks. The diode is soldered in from left to right or vice versa as required.

A label can be snapped on to the middle of each terminal at the front. Further labels can also be mounted flat on the side of the terminals.

### Technical specifications





	8WH2 003-5DF00 8WH2 003-5CF00
Dimensions	
• Width/length/cover width in mm	5.5 / 60.5 / 2.2
• Height HV-M ... (NS 35/7.5 / NS 35/15) in mm	36.5 / 44
Technical specifications acc. to IEC/DIN VDE	
• Max. load current in A / cross-section in mm <sup>2</sup>	Determined by the diode / 4
• Rated impulse withstand voltage in kV / pollution degree	4 / 3
• Overvoltage category / molded plastic group	III / I
Connection capacities	
• Flexible with end sleeve, with plastic sleeve in mm <sup>2</sup>	0.25 ... 2.5
• Flexible with end sleeve, without plastic sleeve in mm <sup>2</sup>	0.25 ... 2.5
• Flexible with two-wire connection end sleeve, with plastic sleeve in mm <sup>2</sup>	0.5
Stripped length in mm	10
Plug gauge (IEC 60947-1)	A3
Molded plastic type	PA
• Flammability class acc. to UL 94	V0
Approval data (UL/cUL and CSA)	
• Rated voltage / rated current / conductor sizes	
- UL/cUL: V/A/AWG	600 / 20 / 26-12
- CSA: V/A/AWG	--

# 8WH2 Spring-Loaded Terminals

## 8WH diode terminals

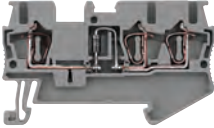
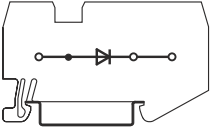
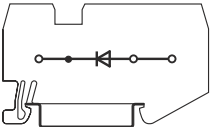
4

### Selection and ordering data

Version	Order No.	MOQ*	
<b>Terminal size 2.5 mm<sup>2</sup></b>			
 8WH2 003-5DF00   <small>I201_12712</small> 8WH2 003-5DF00	<b>Diode terminals, terminal size 2.5 mm<sup>2</sup>, with three clamping points</b> <ul style="list-style-type: none"> <li>• Uninterrupted limiting current: 0.5 A</li> <li>• Blocking voltage: 1300 V</li> <li>• Terminal width 5.2 mm</li> <li>• <math>C_{us}</math></li> <li>• Connection data               <ul style="list-style-type: none"> <li>- Rigid 0.08 ... 4 mm<sup>2</sup></li> <li>- Flexible 0.08 ... 2.5 mm<sup>2</sup></li> <li>- AWG 28-12</li> <li>- <math>I</math> = the maximum current is determined by the diode</li> <li>- <math>U = 500</math> V</li> </ul> </li> <li>• With integrated diode</li> <li>• Integrated: diode 1N 4007</li> </ul>	<b>8WH2 003-5DF00</b> <b>8WH2 003-5CF00</b>	50 units 50 units
 <small>I201_12713</small> 8WH2 003-5CF00	<b>Versions</b> <ul style="list-style-type: none"> <li>• Let-through from left to right</li> <li>• Let-through from right to left</li> </ul>		
<b>Accessories</b>			
 8WH9 070-0GA00	<b>Compartment partitions, for terminal size 1.5 to 4 mm<sup>2</sup> and three clamping points</b>	<b>8WH9 070-0GA00</b>	50 units
 8WH9 000-4GA00	<b>Covers, for terminal size 1.5 ... 2.5 mm<sup>2</sup> and three clamping points</b>	<b>8WH9 000-4GA00</b>	50 units
 8WH9 000-0GA00	<b>Cover segments, for terminal size 1.5 and 2.5 mm<sup>2</sup> and three clamping points</b>	<b>8WH9 000-0GA00</b>	10 units

Note:

For general accessories for 8WH terminal blocks, [see chapter 8](#).

### Overview

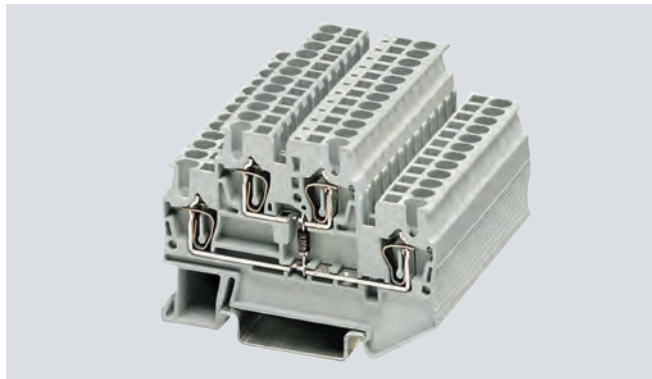

Two-tier diode terminals can be used together with different versions to implement many different wiring tasks.

The following circuits are possible in the tightest spaces:

- Freewheel diode circuits
- Lamp test circuits
- Signaling and fault signaling circuits.

The clamping points of two-tier terminals can be inscribed with flat labels.

### Technical specifications

	8WH2 020- 5AF00, 5DF00, 5BF00	5HF00, 5FF00, 5KF00, 5EF00, 5GF00	5JF30, 5JF80
Dimensions			
• Width/length/cover width in mm	5.2 / 67.5 / 2.2		
• Height (NS 35/7.5 / NS 35/15) in mm	47.5 / 55		
Technical specifications acc. to IEC/DIN VDE			
• Max. load current in A (not via diodes) / cross-section in mm <sup>2</sup>	26 / 4		
• Rated impulse withstand voltage in kV / pollution degree	4 / 3		
• Overvoltage category / molded plastic group	III / I		
Connection capacities			
• Flexible with end sleeve, with plastic sleeve in mm <sup>2</sup>	0.25 ... 2.5		
• Flexible with end sleeve, without plastic sleeve in mm <sup>2</sup>	0.25 ... 2.5		
• Flexible with two-wire connection end sleeve, with plastic sleeve in mm <sup>2</sup>	0.5		
Stripped length in mm	10		
Plug gauge (IEC 60947-1)	A3		
Molded plastic type	PA		
• Flammability class acc. to UL 94	V0		
Approval data (UL/cUL and CSA)			
• Rated voltage / rated current / conductor sizes			
- UL/cUL: in V/A / AWG	300 / 20 / 26-12		
- CSA: in V/A / AWG	300 / 20 / 26-12		

### Selection and ordering data

Version	Order No.	MOQ*	
<b>General data</b>			
<b>cULus</b>			
<b>Terminal size 2.5 mm<sup>2</sup></b>			
<p>8WH2 020-5AF00</p>	<b>Two-tier diode terminals, size 2.5 mm<sup>2</sup>, with one diode</b> <ul style="list-style-type: none"> <li>• Terminal width 5.2 mm</li> <li>• Connection data                             <ul style="list-style-type: none"> <li>- Rigid 0.08 ... 4 mm<sup>2</sup>, flexible 0.08 ... 2.5 mm<sup>2</sup>, AWG 28-12</li> <li>- <math>I = 26 \text{ A}</math>, <math>U = 500 \text{ V}</math></li> </ul> </li> <li>• Maximum current determined by diode</li> <li>• Integrated: diode 1N 4007                             <ul style="list-style-type: none"> <li>- Blocking voltage: 1300 V, uninterrupted limiting current: 0.5 A</li> </ul> </li> </ul>		
	<b>Circuit diagram</b> 	<b>Versions</b> Let-through from top to bottom	<b>8WH2 020-5AF00</b> 50 units
		Let-through from bottom left to top right	<b>8WH2 020-5DF00</b> 50 units
		Let-through from bottom to top	<b>8WH2 020-5BF00</b> 50 units

\* You can order this quantity or a multiple thereof.

# 8WH2 Spring-Loaded Terminals

## 8WH two-tier diode terminals

4

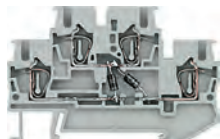

8WH2 020-5HF00

### Two-tier-diode terminals, terminal size 2.5 mm<sup>2</sup>, with two diodes

- Terminal width 5.2 mm
- Connection data
  - Rigid 0.08 ... 4 mm<sup>2</sup>
  - Flexible 0.08 ... 2.5 mm<sup>2</sup>
  - AWG 28-12
  - $I = 26 \text{ A}$ ,  $U = 500 \text{ V}$
- Maximum current determined by diode
- Integrated: diode 1N 4007
  - Blocking voltage: 1300 V
  - Uninterrupted limiting current: 0.5 A

#### Circuit diagram

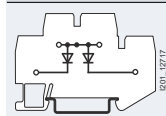

#### Versions

Let-through from top to bottom left and from top to bottom right

**8WH2 020-5HF00**

50 units

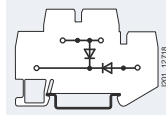

Let-through from top to bottom left and from bottom right to bottom left

**8WH2 020-5KF00**

50 units

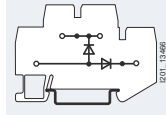

Let-through from bottom left to top and from bottom left to bottom right

**8WH2 020-5EF00**

50 units

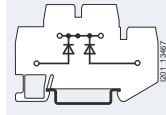

Let-through from bottom left to top and from bottom right to top

**8WH2 020-5GF00**

50 units

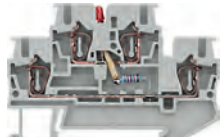

8WH2 020-5JF30

### Two-tier diode terminals, terminal size 2.5 mm<sup>2</sup>, with LED

- Terminal width 5.2 mm
- Connection data
  - Rigid 0.08 ... 4 mm<sup>2</sup>
  - Flexible 0.08 ... 2.5 mm<sup>2</sup>
  - AWG 28-12
  - $I = 26 \text{ A}$
  - $U = 500 \text{ V}$

#### Versions

- 15 to 30 V DC / 2.5 to 7.5 A
- 110 to 230 V AC/DC / 0.5 to 1.0 A (glow lamp)

**8WH2 020-5JF30**

50 units

**8WH2 020-5JF80**

50 units

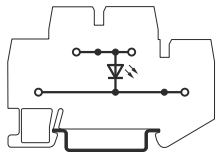

8WH2 020-5JF30

### Accessories



8WH9 070-0BA00

**Compartment partitions, for terminal size 1.5 to 4 mm<sup>2</sup>**

**8WH9 070-0BA00**

50 units



8WH9 000-1VA00

**Covers, for terminal size 1.5 and 2.5 mm<sup>2</sup>**

**8WH9 000-1VA00**

50 units

Note:

For general accessories for 8WH terminal blocks, see chapter 8.

# 8WH5 Combination Plug-In Terminals

# 5

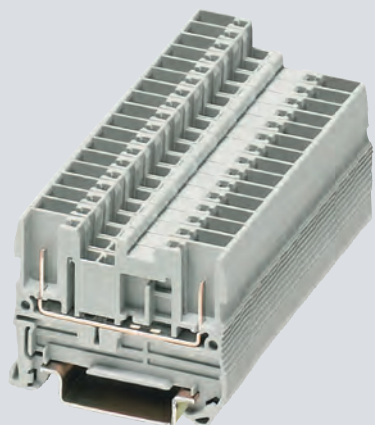

5/2	<b>Introduction</b>
5/5	<b>8WH5 through-type terminals<sup>1)</sup></b>
5/7	<b>8WH5 hybrid through-type terminals with iPo connection</b>
5/8	<b>8WH9 plugs<sup>1)</sup></b>

<sup>1)</sup> Also available as a PE version

# 5

## **More technical product information:**

Service&Support Portal:  
[www.support.automation.siemens.com](http://www.support.automation.siemens.com)

Product List:  
Technical specifications



Entry List:  
Updates / Downloads / FAQ /  
Manuals / Operating instructions /  
Characteristic curves / Certificates

# 8WH5 Combination Plug-In Terminals

## Introduction

### Overview

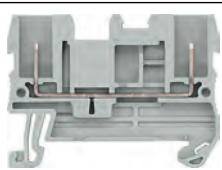
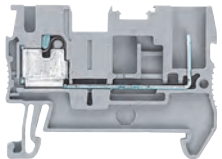
5

	Devices	Page	Function
	8WH5 through-type terminals	5/5	Terminals for the connection of combination plug-in terminals
	8WH5 hybrid through-type terminals with iPo connection	5/7	Terminals for the connection of combination plug-in terminals
	8WH9 plugs	5/8	For connection of combination plugs for fast wiring

### Features

Conductor cross-section	Terminal type <sup>1)</sup>	Color	Combination plugs		Order No. (digits 8 ... 12)
			Terminal type → Design → No. of clamping points → Order No. (digits 1 ... 7) →	Standard 4 8WH5 004	
2.5 mm <sup>2</sup>	Through-type	Gray	✓	✓	0AF00
		Blue	✓	✓	0AF01
		PE Green/yellow	✓	✓	0CF07

### Benefits

#### High-performance contact

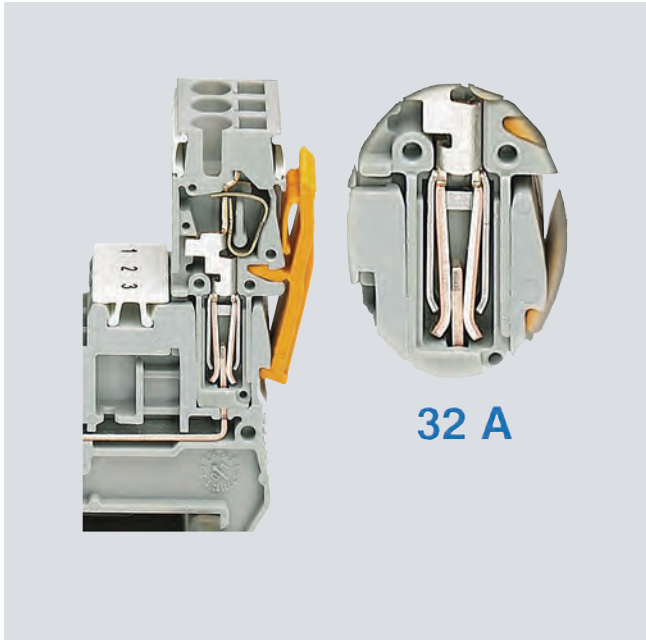

The advanced plug-in system of the combination plug-in terminals enables plug-in wiring up to a rated current of 32 A and a rated voltage of 800 V. The contact system withstands extreme vibration thanks to the integral overspring.

#### Fingerproof design

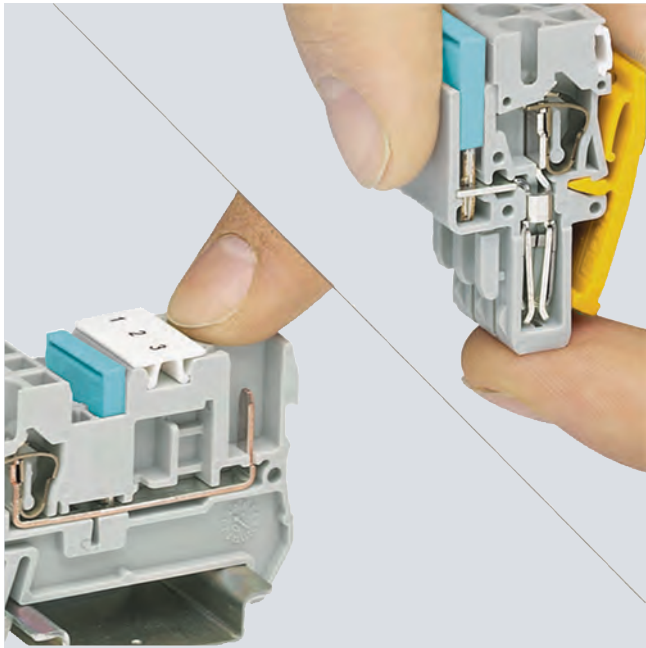

With its fingerproof base terminals and plugs, the combination plug-in terminal system provides maximum user protection. As well as enhancing safety, this provides exceptional flexibility during configuration: the power can be supplied either through the terminals or the plugs.

#### Time and cost-saving potential distribution

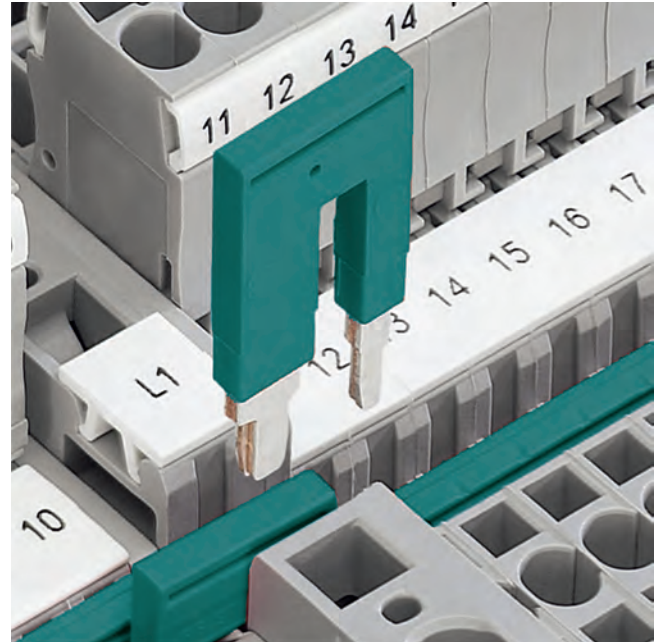

When feeding in large cross-sections, the reducing comb enables time and cost-saving distribution of the potential. For example, it can link a 10 mm<sup>2</sup> through-type terminal to a 2.5 mm<sup>2</sup> through-type terminal and two clamping points.

#### Standardized connecting comb system

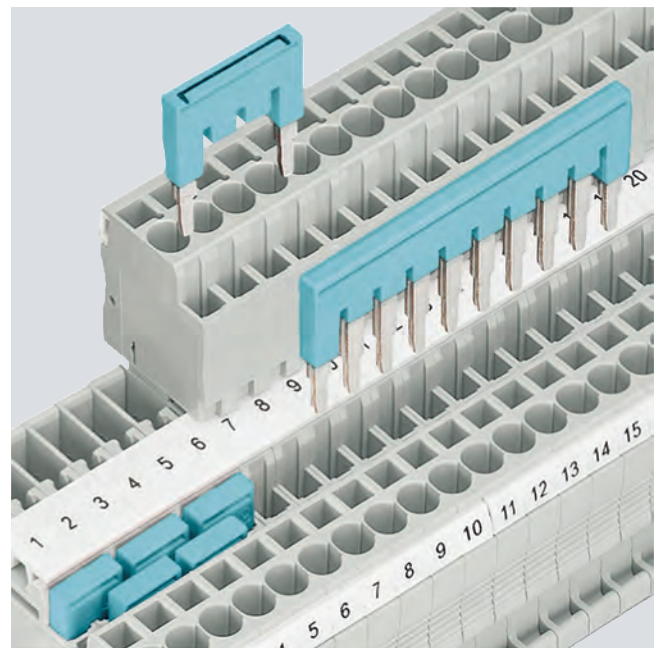

The standardized connecting comb system allows up to 50 terminals to be connected efficiently and quickly with a single jumper. Teeth can be removed to skip individual terminals.

# 8WH5 Combination Plug-In Terminals

5

## Introduction

### Universal plug-in zone

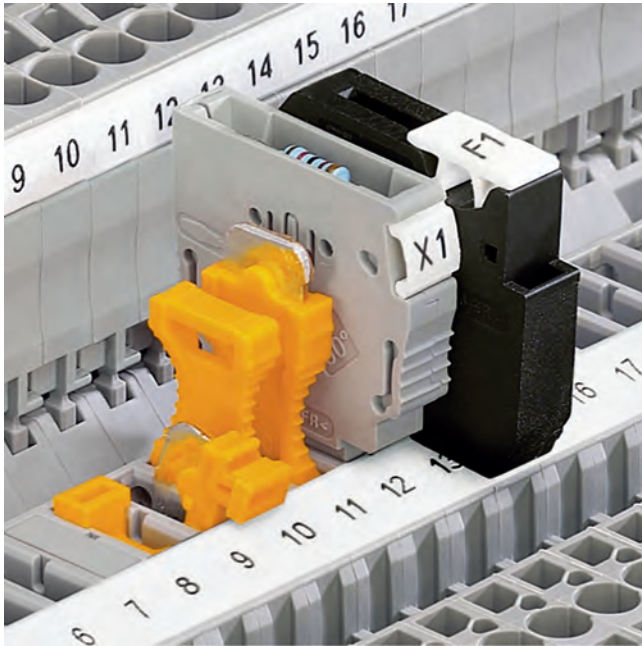

The universal plug-in zone of the isolating terminal can accommodate isolated through-type connectors, isolating plugs, component connectors and fused connectors.

### Assembling test adapters

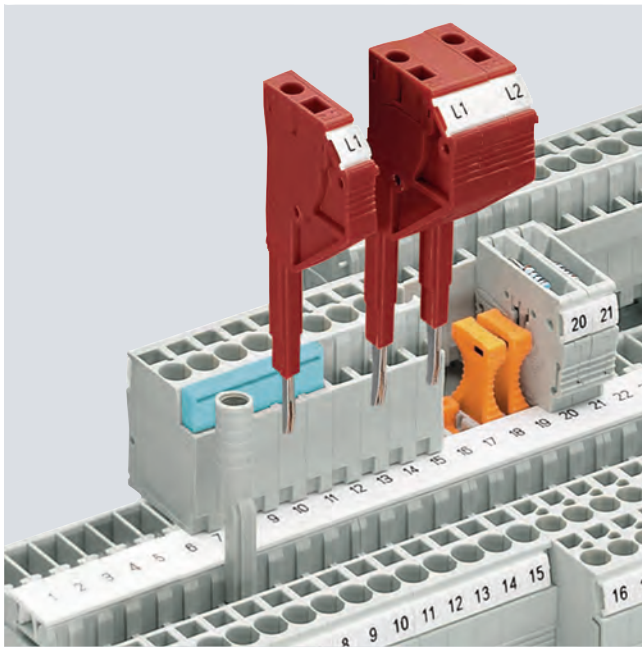

Test adapters are available for  $\varnothing 4$  mm test and safety test plugs. Test plugs can be individually assembled, thanks to the modular design of the test plugs. Measuring leads can be connected over a  $1.5 \text{ mm}^2$  spring-loaded terminal.

### Coding the combination plug-in terminals

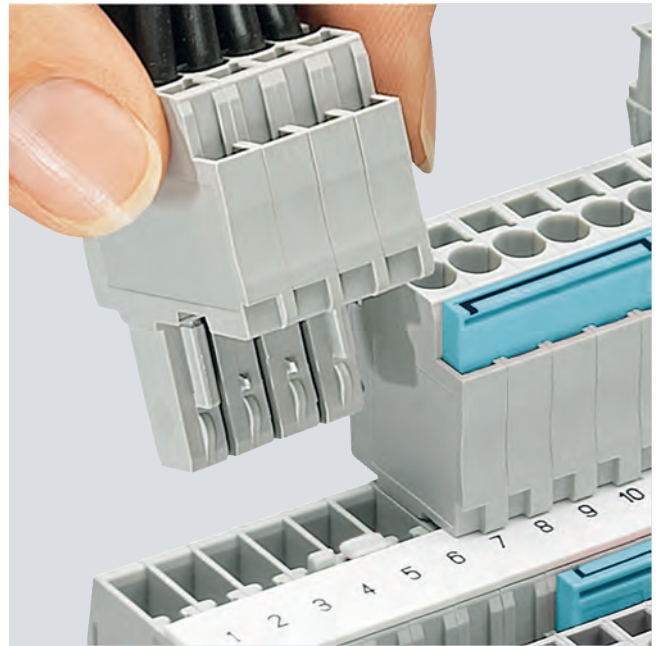

The combination plug-in terminals can be coded with the pin on the plug. The pin is simply removed from the plug, rotated and fitted in the coding position of the base terminal.

### Snap-on strain relief

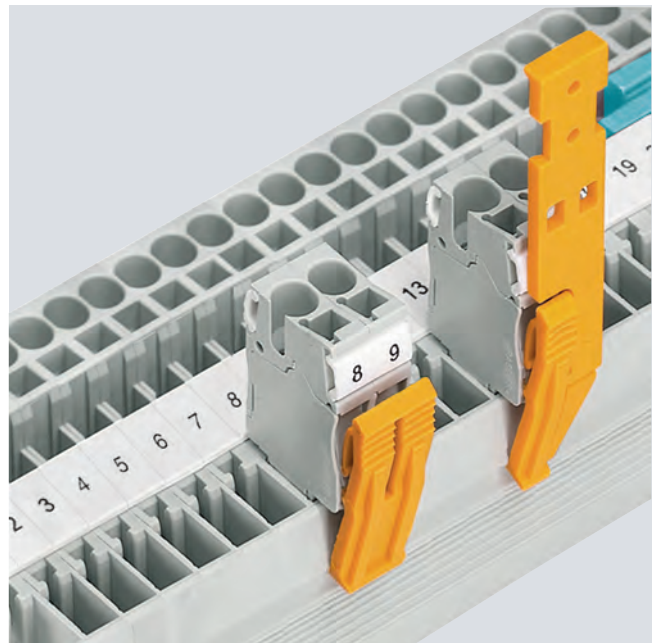

Snap-on clamps are available to relieve cable strain at the plugs. Latches are also available to secure the plugs firmly to the base terminals.

### Overview

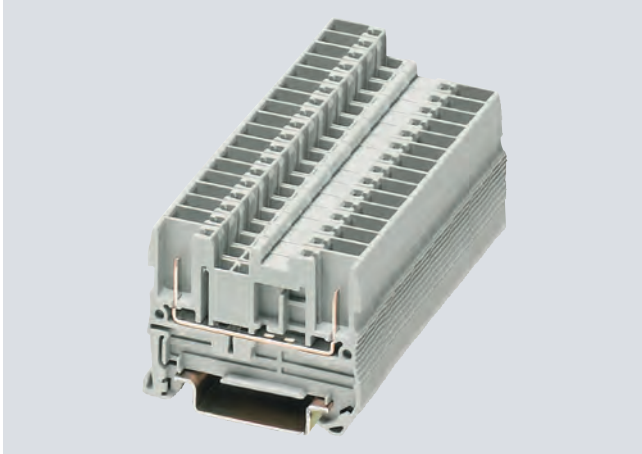

Plugs can be connected at both ends of the terminal using the through-type terminals of the combination plug-in terminals. This makes the combination plug-in terminal system even more flexible and allows the terminals to be used as connecting elements between modules.

The plugs used have a terminal size of 2.5 mm<sup>2</sup>, thus enabling continued use of familiar accessories, such as latches, strain relief and shield connectors.

PE terminals with the same contour are available for the base terminals. These are simply snapped onto the support rail to establish a connection to ground potential.

A label can be snapped on to the middle of each terminal at the front. Further labels can also be mounted flat on the side of the terminals.

### Technical specifications

	8WH5 000-0AF00, 8WH5 000-0AF01	8WH5 004-0AF00, 8WH5 004-0AF01	8WH5 000-0CF07	8WH5 004-0CF07
Dimensions				
• Width/length/cover width in mm	5.2 / 48.5 / 2.2	5.2 / 89.5 / 2.2	5.2 / 48.5 / 2.2	5.2 / 89.5 / 2.2
• Height (TS 35/7.5 / TS 35/15) in mm	36.5 / 44	36.5 / 44	36.5 / 44	36.5 / 44
Technical specifications acc. to IEC/DIN VDE				
• Max. load current in A <sup>1)</sup> / cross-section in mm <sup>2</sup>	24 / 4	24 / 4	--	--
• Rated impulse withstand voltage in kV / pollution degree	6 / 3			
• Overvoltage category / molded plastic group	III / I			
Connection capacities				
• Flexible with end sleeve, with plastic sleeve in mm <sup>2</sup>	0.25 ... 2.5			
• Flexible with end sleeve, without plastic sleeve in mm <sup>2</sup>	0.25 ... 2.5			
• Flexible with two-wire connection end sleeve, with plastic sleeve in mm <sup>2</sup>	0.5			
Molded plastic type	PA			
• Flammability class acc. to UL 94	V0			
Approval data (UL/cUL and CSA)				
• Rated voltage / rated current / conductor sizes			-- / -- / --	-- / -- / --
- UL/cUL: in V/A / AWG	300 / 20 / --		See section "8WH9 Plugs" on page 5/8	
- CSA: in V/A / AWG	--			
Support rails/protective conductor busbars	--			See section "Support rails" on page 1/3

1) Derating of the load current is necessary for higher temperatures and/or multi-pole combination plug versions.

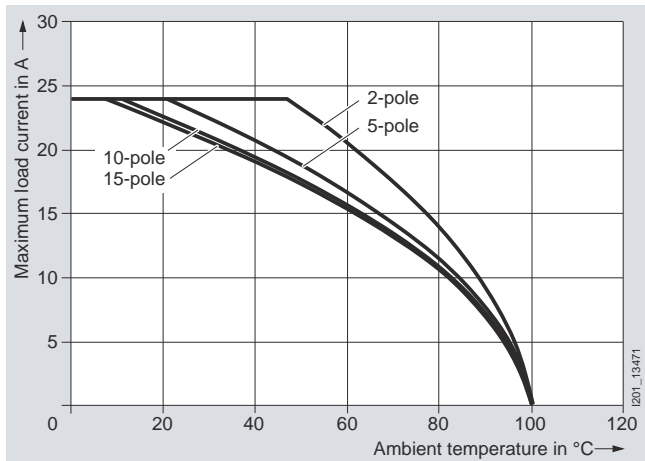

Derating curve for 8WH5 000-0AF00

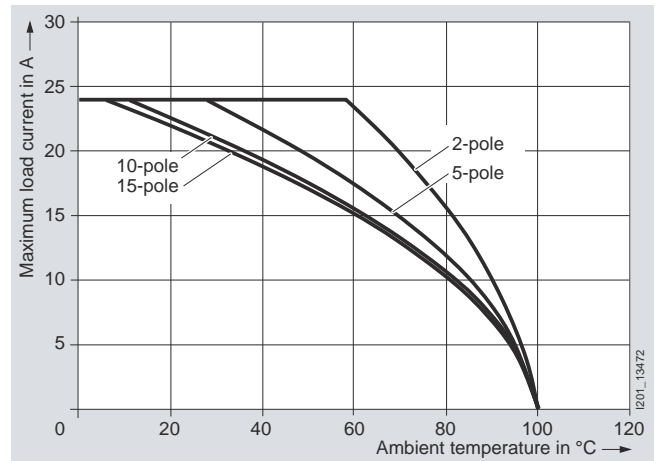







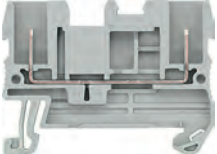

Derating curve for 8WH5 004-0AF00

# 8WH5 Combination Plug-In Terminals

## 8WH5 through-type terminals

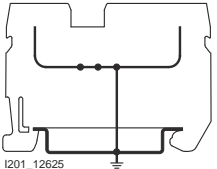
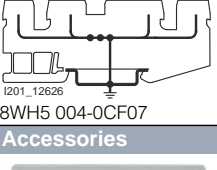
5

### Selection and ordering data

	Version	Order No.	MOQ*
<b>Terminal size 2.5 mm<sup>2</sup></b>			
 <p>8WH5 000-0AF00</p>  <p>8WH5 004-0AF00</p>	<b>Through-type terminals, terminal size 2.5 mm<sup>2</sup></b> <ul style="list-style-type: none"> <li>Terminal width 5.2 mm</li> <li>C<sub>us</sub></li> <li>IEC 61 984                             <ul style="list-style-type: none"> <li>- I = 24 A</li> <li>- U = 500 V</li> </ul> </li> </ul>	<b>8WH5 000-0AF00</b> <b>8WH5 004-0AF00</b>  <b>8WH5 000-0AF01</b> <b>8WH5 004-0AF01</b>	50 units 50 units  50 units 50 units
	<b>Versions</b> <ul style="list-style-type: none"> <li>Gray                             <ul style="list-style-type: none"> <li>- Two clamping points</li> <li>- Four clamping points</li> </ul> </li> <li>Blue                             <ul style="list-style-type: none"> <li>- Two clamping points</li> <li>- Four clamping points</li> </ul> </li> </ul>		
	<b>Note</b> On the terminal with four clamping points, the total current through all connected conductors must not exceed the max. load current.		
 <p>8WH5 000-0CF07</p>  <p>8WH5 004-0CF07</p>	<b>PE through-type terminals, terminal size 2.5 mm<sup>2</sup></b> <ul style="list-style-type: none"> <li>Green/yellow</li> <li>Terminal width 5.2 mm</li> <li>C<sub>us</sub></li> <li>IEC 61 984</li> </ul>	<b>8WH5 000-0CF07</b> <b>8WH5 004-0CF07</b>	50 units 50 units
	<b>Versions</b> <ul style="list-style-type: none"> <li>Two clamping points</li> <li>Four clamping points</li> </ul>		
 <p>I201_12625</p> <p>8WH5 000-0CF07</p>  <p>I201_12626</p> <p>8WH5 004-0CF07</p>			
<b>Accessories</b>			
 <p>8WH9 070-0AA00</p>	<b>Compartment partitions, for terminal size 1.5 to 4 mm<sup>2</sup></b> <ul style="list-style-type: none"> <li>For visual and electrical separation of terminal groups</li> <li>2 mm thick</li> </ul>	<b>8WH9 070-0AA00</b> <b>8WH9 070-0HA00</b>	50 units 50 units
 <p>8WH9 000-1LA00</p>	<b>Cover segments, for terminal size 2.5 mm<sup>2</sup> and four terminals</b> <ul style="list-style-type: none"> <li>Gray</li> <li>For covering multi-wire terminals when mounting two-wire terminals side-by-side</li> </ul>	<b>8WH9 000-1LA00</b>	50 units
 <p>8WH9 000-4NA00</p>	<b>Covers, for terminal size 2.5 mm<sup>2</sup></b> Gray	<b>8WH9 000-1GA00</b> <b>8WH9 000-4NA00</b>	50 units 50 units
	<b>Versions</b> <ul style="list-style-type: none"> <li>Two clamping points</li> <li>Four clamping points</li> </ul>		

Note:

For general accessories for 8WH terminal blocks, [see chapter 8](#).

# 8WH5 Combination Plug-In Terminals

8WH5 hybrid through-type terminals with iPo connection

## Overview

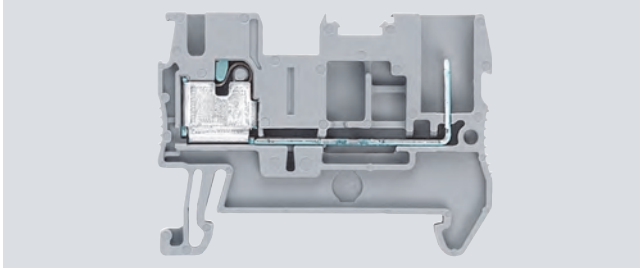

The 8WH5 hybrid through-type terminals with iPo connection provide a modular solution for fast, flexible wiring of plants and machines. They combine the advantages of the combination terminal system with those of the iPo terminals.



A label can be snapped on to the middle of each terminal at the front. Further labels can also be mounted flat on the side of the terminals.

## Technical specifications

	8WH5 100-2PF00	8WH5 100-3PF07
Dimensions		
• Width/length/cover width in mm	5.2 / 48.5 / 2.2	
• Height (TS 35/7.5 / TS 35/15) in mm	36.5	
Technical specifications acc. to IEC/DIN VDE		
• Max. load current in A <sup>1)</sup> / cross-section in mm <sup>2</sup>	24	--
• Rated impulse withstand voltage in kV / pollution degree	500	--
Connection capacity, 1 conductor		
• Rigid	0.14 ... 2.5	
• Flexible with end sleeve without / with plastic sleeve in mm <sup>2</sup>	0.14 ... 2.5	
Molded plastic type		
• Flammability class acc. to UL 94	V0	
Approval data (UL/cUL and CSA)		
• Rated voltage / rated current / conductor sizes		
- UL/cUL: in V/A / AWG	500 / 300 / 26-12	
- CSA: in V/A / AWG	-- / --	
Support rails/protective conductor busbars	--	See section "Support rails" on page 1/3

<sup>1)</sup> Derating of the load current is necessary for higher temperatures and/or multi-pole combination plug versions.

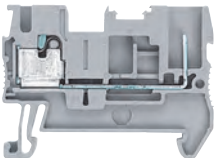
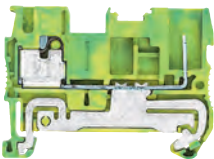
## Selection and ordering data

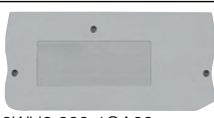
Version	DT	Order No.	Price per PU	PU (UNIT, SET, M)	PS*/P. unit	PG
<b>Hybrid through-type terminals with iPo connection, terminal size 2.5 mm<sup>2</sup></b>						
 8WH5 100-2PF00 <b>Hybrid through-type terminals, terminal size 2.5 mm<sup>2</sup></b> <ul style="list-style-type: none"> <li>• Gray</li> <li>• Terminal width 5.2 mm</li> <li>• Rated current 24 A / cross-section 2.5 mm<sup>2</sup></li> <li>• Rated voltage <math>U_n = 500</math> V</li> <li>• Rigid 0.14 ... 4 mm<sup>2</sup></li> <li>• Flexible with end sleeve 0.14 ... 2.5 mm<sup>2</sup></li> <li>• Stripped length 10 mm</li> </ul>		<b>8WH5 100-2PF00</b>		1 50 units		044
 8WH5 100-3PF07 <b>PE hybrid through-type terminals, terminal size 2.5 mm<sup>2</sup></b> <ul style="list-style-type: none"> <li>• Green/yellow</li> <li>• Terminal width 5.2 mm</li> <li>• Rigid 0.14 ... 4 mm<sup>2</sup></li> <li>• Flexible with end sleeve 0.14 ... 2.5 mm<sup>2</sup></li> <li>• Connection type: plug-in spring-loaded connection</li> <li>• Stripped length 10 mm</li> </ul>		<b>8WH5 100-3PF07</b>		1 50 units		044
<b>Accessories</b>						
 8WH9 070-0HA00 <b>Compartment partitions</b> For terminal size 1.5 ... 4 mm <sup>2</sup> and four clamping points		<b>8WH9 070-0HA00</b>		100 50 units		044
 8WH9 000-1GA00 <b>Covers</b> For terminal size 2.5 mm <sup>2</sup> and two clamping points		<b>8WH9 000-1GA00</b>		100 50 units		044

Note:

For general accessories for 8WH terminal blocks, see chapter 8.

\* You can order this quantity or a multiple thereof.

# 8WH5 Combination Plug-In Terminals

## 8WH9 plugs

5

### Overview

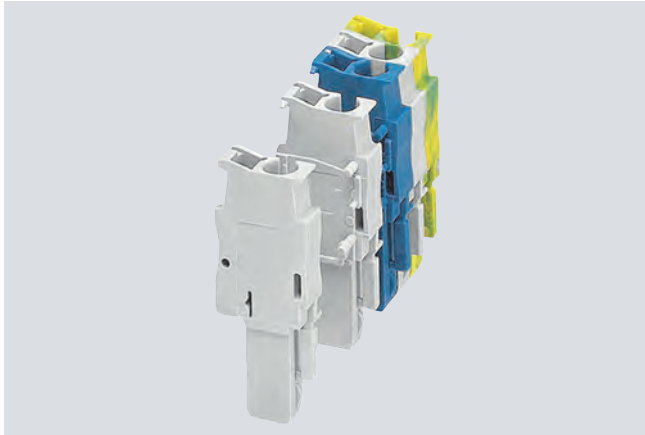

Assembled by the user in-situ from single-pole plug elements, the combination plug-in terminals in kit form provide a customized solution for every task.

For the existing plugs with terminal sizes 2.5 mm<sup>2</sup> and 4 mm<sup>2</sup>, and the plug with comb connection and terminal size 2.5 mm<sup>2</sup>, single-pole basic versions in the colors gray, blue and green-yellow are available.

A left and a right element are needed for the two ends of the assembled connector for each multi-pole plug. The number of middle elements depends on the plug's required number of poles. The individual elements are simply pushed together and latched with securing pins. The right-hand component has an integrated cover, which covers the plug block.

Labels enable flat inscription of the plugs.

### Design

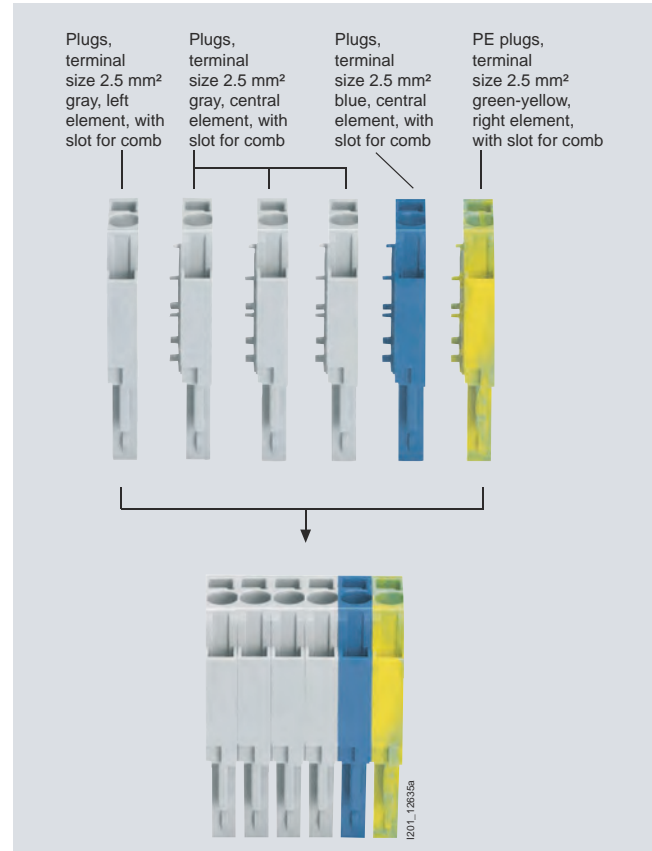

Example of a 6-pole plug

### Technical specifications

	<b>8WH9 040-1AB00</b> <b>8WH9 040-1AB01</b> <b>8WH9 040-1BB00</b> <b>8WH9 040-1BB01</b> <b>8WH9 040-1CB00</b> <b>8WH9 040-1CB01</b> <b>8WH9 040-1DB00</b> <b>8WH9 040-1DB01</b> <b>8WH9 040-1EB00</b> <b>8WH9 040-1EB01</b> <b>8WH9 040-1FB00</b> <b>8WH9 040-1FB01</b>	<b>8WH9 040-1AB07</b> <b>8WH9 040-1BB07</b> <b>8WH9 040-1CB07</b> <b>8WH9 040-1DB07</b> <b>8WH9 040-1EB07</b> <b>8WH9 040-1FB07</b>	<b>8WH9 050-1KB00</b> <b>8WH9 050-1KB01</b> <b>8WH9 050-1LB00</b> <b>8WH9 050-1LB01</b> <b>8WH9 050-1MB00</b> <b>8WH9 050-1MB01</b>	<b>8WH9 050-1KB07</b> <b>8WH9 050-1LB07</b> <b>8WH9 050-1MB07</b>
Dimensions	--			
• Width/length/cover width in mm	--			
• Height (TS 35/7.5 / TS 35/15) in mm	--			
Technical specifications acc. to IEC/DIN VDE				
• Max. load current in A <sup>1)</sup> / cross-section in A / mm <sup>2</sup>	24 / 4		32 / 6	
• Rated impulse withstand voltage in kV / pollution degree	6 / 3		8 / 3	
• Overvoltage category / molded plastic group	III / I			
Connection capacities				
• Flexible with end sleeve, with plastic sleeve in mm <sup>2</sup>	0.25 ... 2.5		0.25 ... 4	
• Flexible with end sleeve, without plastic sleeve in mm <sup>2</sup>	0.25 ... 2.5		0.25 ... 4	
• Flexible with two-wire connection end sleeve, with plastic sleeve in mm <sup>2</sup>	0.5		0.5 ... 1	
Stripped length	10			
Plug gauge (IEC 60947-1)	A3		A4	
Molded plastic type	PA			
• Flammability class acc. to UL 94	V0			
Approval data (UL/cUL and CSA)				
• Rated voltage / rated current / conductor sizes	600 / 20 / 26-12		Applied for Applied for	
- UL/cUL: in V/A / AWG	--			
- CSA: in V/A / AWG	--			
Support rails/protective conductor busbars	--	See section "Support rails" on page 1/3	--	See section "Support rails" on page 1/3

<sup>1)</sup> Derating of the load current is necessary for higher temperatures and/or multi-pole combination plug versions.

### Selection and ordering data









Version	Order No.	MOQ*		
<b>Terminal size 2.5 mm<sup>2</sup></b>				
 <p><b>8WH9 040-1DB00 / -1AB00</b></p>	<p><b>Plugs, terminal size 2.5 mm<sup>2</sup></b></p> <ul style="list-style-type: none"> <li>Terminal width 5.2 mm</li> <li>  </li> <li>  </li> <li>Connection data                             <ul style="list-style-type: none"> <li>Rigid 0.08 ... 4 mm<sup>2</sup></li> <li>Flexible 0.08 ... 2.5 mm<sup>2</sup></li> <li>AWG 28-12</li> <li>I = 24 A</li> <li>U = 500 V</li> </ul> </li> <li>Number of poles = 1</li> </ul> <p><b>Versions</b></p> <ul style="list-style-type: none"> <li><b>Gray</b> <ul style="list-style-type: none"> <li>Left element, with slot for comb</li> <li>Central element, with slot for comb</li> <li>Right element, with slot for comb</li> <li>Left element, without slot for comb</li> <li>Central element, without slot for comb</li> <li>Right element, without slot for comb</li> </ul> </li> <li><b>Blue</b> <ul style="list-style-type: none"> <li>Left element, with slot for comb</li> <li>Central element, with slot for comb</li> <li>Right element, with slot for comb</li> <li>Left element, without slot for comb</li> <li>Central element, without slot for comb</li> <li>Right element, without slot for comb</li> </ul> </li> </ul>	<p><b>8WH9 040-1DB00</b> 50 units</p> <p><b>8WH9 040-1EB00</b> 50 units</p> <p><b>8WH9 040-1FB00</b> 50 units</p> <p><b>8WH9 040-1AB00</b> 50 units</p> <p><b>8WH9 040-1BB00</b> 50 units</p> <p><b>8WH9 040-1CB00</b> 50 units</p> <p><b>8WH9 040-1DB01</b> 50 units</p> <p><b>8WH9 040-1EB01</b> 50 units</p> <p><b>8WH9 040-1FB01</b> 50 units</p> <p><b>8WH9 040-1AB01</b> 50 units</p> <p><b>8WH9 040-1BB01</b> 50 units</p> <p><b>8WH9 040-1CB01</b> 50 units</p>		
 <p><b>8WH9 040-1EB00 / -1BB00</b></p>				
 <p><b>8WH9 040-1FB00 / -1CB00</b></p>				
<b>PE plugs, terminal size 2.5 mm<sup>2</sup></b>				
 <p><b>8WH9 040-1DB07 / -1AB07</b></p>			<ul style="list-style-type: none"> <li>Green/yellow</li> <li>Terminal width 5.2 mm</li> <li>  </li> <li>  </li> <li>Connection data                             <ul style="list-style-type: none"> <li>Rigid 0.08 ... 4 mm<sup>2</sup></li> <li>Flexible 0.08 ... 2.5 mm<sup>2</sup></li> <li>AWG 28-12</li> <li>I = 24 A</li> <li>U = 500 V</li> </ul> </li> <li>Number of poles = 1</li> </ul> <p><b>Versions</b></p> <ul style="list-style-type: none"> <li>Left element, with slot for comb</li> <li>Central element, with slot for comb</li> <li>Right element, with slot for comb</li> <li>Left element, without slot for comb</li> <li>Central element, without slot for comb</li> <li>Right element, without slot for comb</li> </ul>	<p><b>8WH9 040-1DB07</b> 50 units</p> <p><b>8WH9 040-1EB07</b> 50 units</p> <p><b>8WH9 040-1FB07</b> 50 units</p> <p><b>8WH9 040-1AB07</b> 50 units</p> <p><b>8WH9 040-1BB07</b> 50 units</p> <p><b>8WH9 040-1CB07</b> 50 units</p>
 <p><b>8WH9 040-1EB07 / -1BB07</b></p>				
 <p><b>8WH9 040-1FB07 / -1CB07</b></p>				

\* You can order this quantity or a multiple thereof.

# 8WH5 Combination Plug-In Terminals

## 8WH9 plugs

5

	Version	Order No.	MOQ*
<b>Terminal size 4 mm<sup>2</sup></b>			
 <p>8WH9 040-1KB00</p>	<p><b>Plugs, terminal size 4 mm<sup>2</sup>, without slot for comb</b></p> <ul style="list-style-type: none"> <li>Terminal width 6.2 mm</li> <li>Connection data                             <ul style="list-style-type: none"> <li>Rigid 0.08 ... 6 mm<sup>2</sup></li> <li>Flexible 0.08 ... 24 mm<sup>2</sup></li> <li>AWG 28-10</li> <li>I = 32 A</li> <li>U = 800 V</li> </ul> </li> <li>Number of poles = 1</li> </ul>		
 <p>8WH9 040-1LB00</p>	<p><b>Versions</b></p> <ul style="list-style-type: none"> <li>Gray                             <ul style="list-style-type: none"> <li>Left element</li> <li>Central element</li> <li>Right element</li> </ul> </li> <li>Blue                             <ul style="list-style-type: none"> <li>Left element</li> <li>Central element</li> <li>Right element</li> </ul> </li> </ul>	<p><b>8WH9 040-1KB00</b>  <b>8WH9 040-1LB00</b>  <b>8WH9 040-1MB00</b></p> <p><b>8WH9 040-1KB01</b>  <b>8WH9 040-1LB01</b>  <b>8WH9 040-1MB01</b></p>	<p>50 units 50 units 50 units</p> <p>50 units 50 units 50 units</p>
 <p>8WH9 040-1MB00</p>			
<b>PE plugs, terminal size 4 mm<sup>2</sup>, without slot for comb</b>			
 <p>8WH9 040-1KB07</p>	<ul style="list-style-type: none"> <li>Green/yellow</li> <li>Terminal width 6.2 mm</li> <li>Connection data                             <ul style="list-style-type: none"> <li>Rigid 0.08 ... 6 mm<sup>2</sup></li> <li>Flexible 0.08 ... 24 mm<sup>2</sup></li> <li>AWG 28-10</li> <li>I = 32 A</li> <li>U = 800 V</li> </ul> </li> <li>Number of poles = 1</li> </ul>		
 <p>8WH9 040-1LB07</p>	<p><b>Versions</b></p> <ul style="list-style-type: none"> <li>Left element</li> <li>Central element</li> <li>Right element</li> </ul>	<p><b>8WH9 040-1KB07</b>  <b>8WH9 040-1LB07</b>  <b>8WH9 040-1MB07</b></p>	<p>50 units 50 units 50 units</p>
 <p>8WH9 040-1MB07</p>			
<b>Accessories</b>			
 <p>8WH9 050-2BA04</p>	<p><b>Latches</b></p> <p>Number of poles: 2</p> <p><b>Versions</b></p> <ul style="list-style-type: none"> <li>With strain relief</li> <li>Without strain relief</li> </ul>	<p><b>8WH9 050-2BA04</b>  <b>8WH9 050-2AA04</b></p>	<p>50 units 50 units</p>
 <p>8WH9 120-0DB08</p>	<p><b>Shielding</b></p> <ul style="list-style-type: none"> <li>For connection of shielded cables</li> <li>For cables with 5 to 10 mm diameter</li> <li>Black</li> </ul>	<p><b>8WH9 120-0DB08</b></p>	<p>50 units</p>

Note:  
For general accessories for 8WH terminal blocks, [see chapter 8](#).

# 8WH3 Insulation Displacement Terminals

# 6

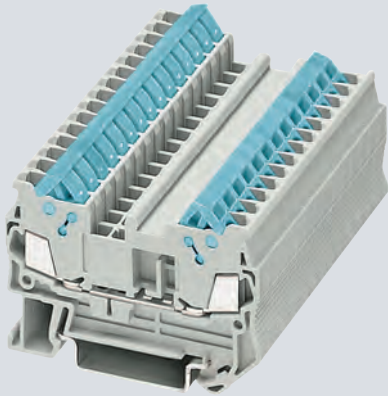

6/2	<b>Introduction</b>
6/5	<b>8WH through-type terminals</b>
6/9	<b>8WH two-tier terminals</b>
6/11	<b>8WH isolating terminals</b>

## More technical product information:

Service&Support Portal:  
[www.support.automation.siemens.com](http://www.support.automation.siemens.com)

Product List:  
Technical specifications

Entry List:  
Updates / Downloads / FAQ /  
Manuals / Operating instructions /  
Characteristic curves / Certificates

# 8WH3 Insulation Displacement Terminals

## Introduction

### Overview

	Devices	Page	Function
	8WH through-type terminals	6/5	Connection up to 2.5 mm <sup>2</sup> of incoming and outgoing conductors
	8WH isolating terminals	6/11	Isolation of the circuit, e.g. for test purposes

6

1) Only the main terminal types are listed here. You will find further versions on the following pages.

### Features

Conductor cross-section	Terminal type <sup>1)</sup>	Terminal type → Design → No. of clamping points → Order No. (digits 1 ... 7) →	Insulation displacement terminal				Order No. (digits 8 ... 12)
			Color	Standard			
				2 8WH3 000	3 8WH3 003	4 8WH3 004	
1.5 mm <sup>2</sup>	Through-type	Gray	✓	✓	✓	✓	0AE00
		Blue	✓	✓	✓	✓	0AE01
	Isolating	Gray	✓	--	--	--	6AE00
		PE Green/yellow	✓	✓	✓	✓	0CE07
2.5 mm <sup>2</sup>	Through-type	Gray	✓	✓	--	--	0AF00
		Blue	✓	✓	--	--	0AF01
	Isolating	Gray	✓	--	--	--	6AF00
		PE Green/yellow	✓	--	--	--	0CF07

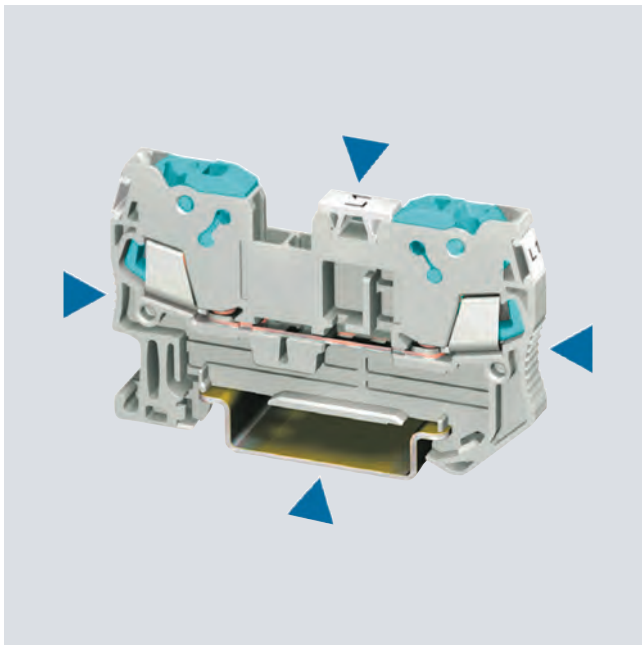

A key feature of the insulation displacement series is its IDC rotary connection. This concept saves considerable space in the control cabinet without impairing other quality features, such as

- Large surface marking
- Maximum connection compartment
- Flexible connecting combs.



Time savings of 60 % and more compared to other connection systems.

With the quick-connect insulation displacement terminal system, there is no need to strip the insulation or protect the splice. The cables only need to be cut to length for contacting within seconds.

# 8WH3 Insulation Displacement Terminals

## Introduction

6

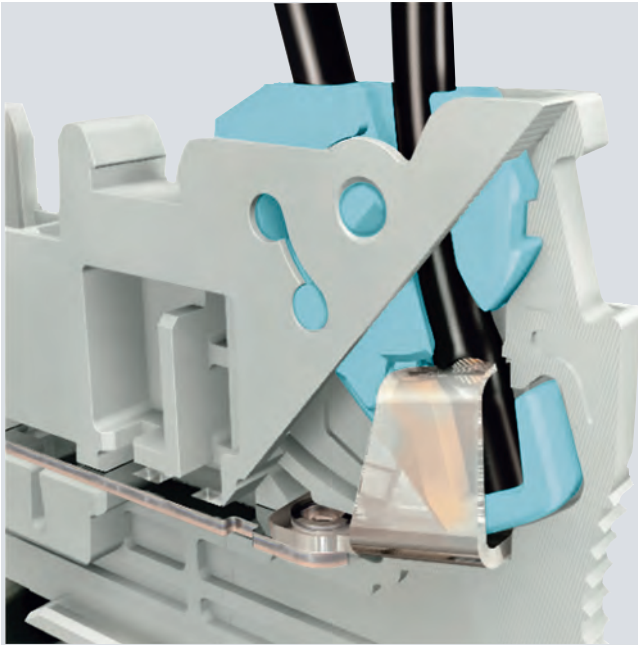

Conductor connections from 0.25 to 2.5 mm<sup>2</sup> are produced by the cutting contact. High-grade special alloys and latching of the switch states ensure reliable electrical connections at all times. Large, spring-loaded contact points ensure 24 A current load rating.

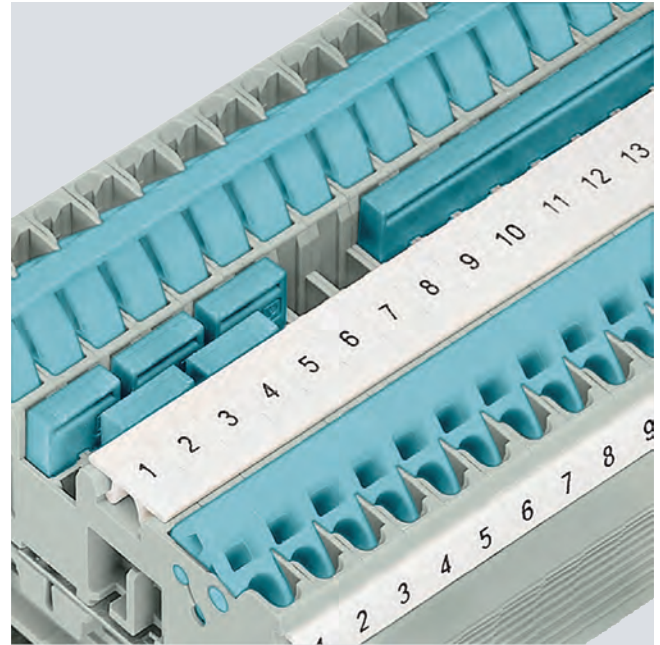

The standardized connecting comb system allows several terminals to be linked efficiently and quickly with a single jumper. The range covers 2 to 50-pole jumpers, which can help considerably to reduce the amount of wiring outlay.

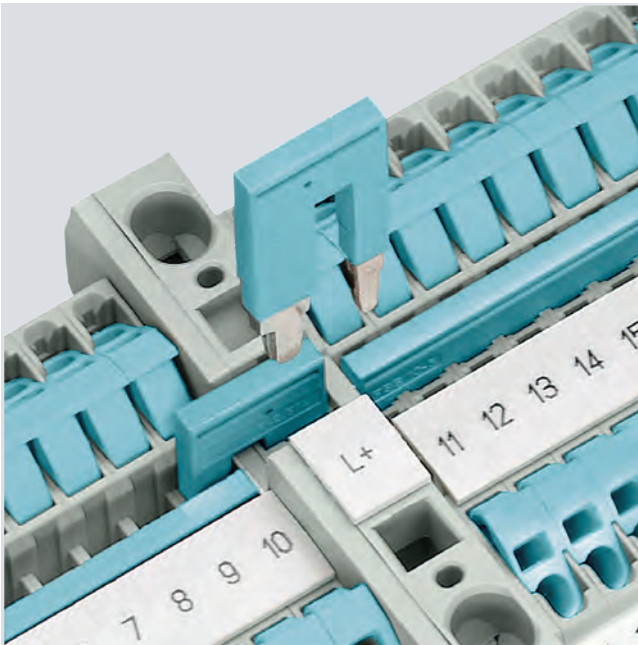

When feeding in large cross-sections, the reducing comb enables time and cost-saving distribution of the potential. For example, it can link a 10 mm<sup>2</sup> spring-loaded through-type terminal to a 1.5 mm<sup>2</sup> insulation displacement through-type terminal and two clamping points - or to a 2.5 mm<sup>2</sup> insulation displacement through-type terminal and two clamping points.

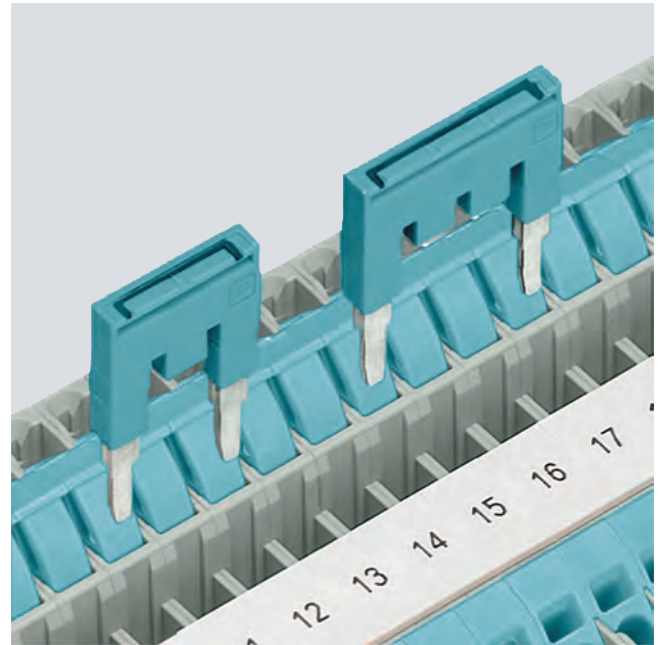

Teeth can be removed from the standard comb in order to skip individual terminals, so that two potentials can run in parallel. A marking option is provided on the top of the connecting comb.

# 8WH3 Insulation Displacement Terminals

## Introduction

6

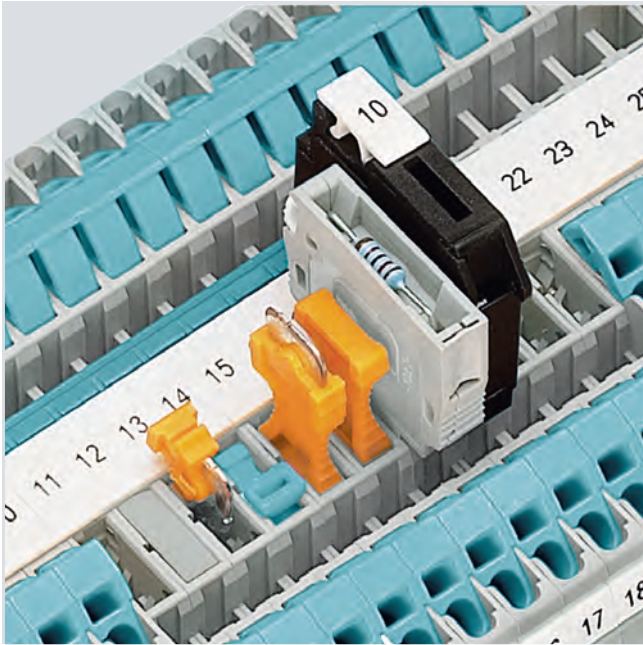

The universal plug-in zone of the isolating terminal can accommodate isolated through-type connectors, isolating plugs, component connectors and fused connectors.



The unambiguous and easy-to-read marking in the center of the terminal is essential for time-saving installation. In addition to the large inscription in the center, each clamping point can also be labeled separately.

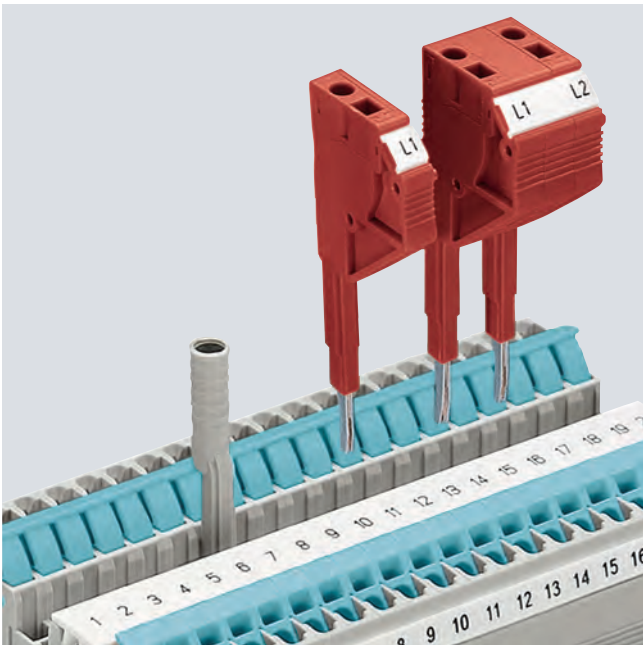

Test adapters are available for  $\varnothing$  4 mm test and safety test plugs. Test plugs can be individually assembled, thanks to the modular design of the test plugs. Measuring leads can be connected over a 1.5 mm<sup>2</sup> spring-loaded/insulation displacement terminal.

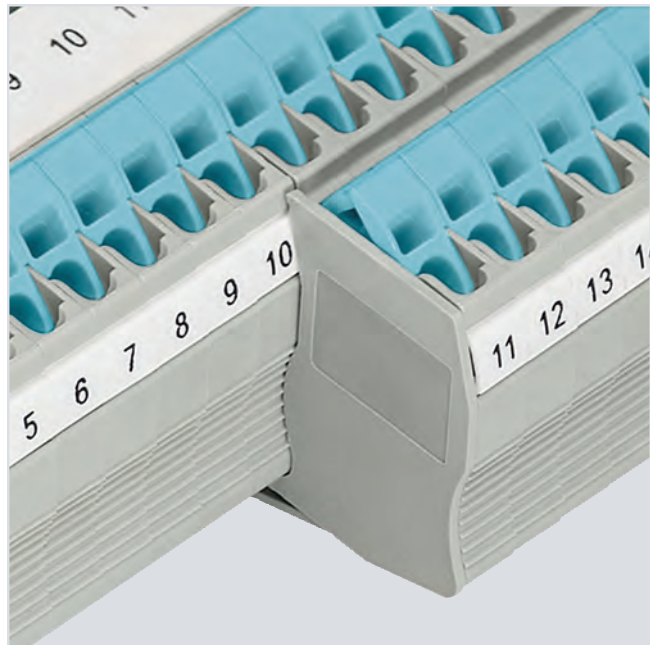

The cover segment is used to cover multi-wire terminals when mounting two-wire terminals side by side. These devices meet all fingerproof requirements.

### Overview

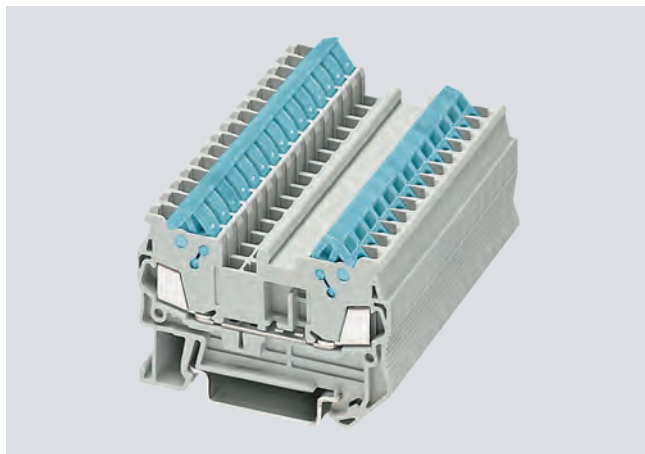

A key feature of the insulation displacement through-type terminal is its compact design. With its clear and space-saving front connection arrangement, this insulation displacement series provides additional space between the cable ducts for wiring. Using the double bridge shaft, it is also possible to use individual chain bridging, as well as a reducing comb, e.g. from a 2.5 mm<sup>2</sup> tension spring through-type terminal to a 35 mm<sup>2</sup> tension spring through-type terminal. Used in this way, reducing combs enable the quick and easy assembly of potential incoming feeders and distributors.

A label can be snapped on to the middle of the terminal at the front. Further labels can also be mounted flat on the side of the terminals.

### Technical specifications







	8WH3 000-0AE00 8WH3 000-0AE01	8WH3 003-0AE00 8WH3 003-0AE01	8WH3 004-0AE00 8WH3 004-0AE01	8WH3 000-0CE07	8WH3 003-0CE07
Dimensions					
• Width/length/cover width in mm	5.2 / 58.8 / 2.2	5.2 / 76.4 / 2.2	5.2 / 94 / 2.2	5.2 / 58.8 / 2.2	5.2 / 76.4 / 2.2
• Height (TS 35/7.5 / TS 35/15) in mm	39.3 / 46.8				
Technical specifications acc. to IEC/DIN VDE					
• Max. load current in A / cross-section in mm <sup>2</sup>	17.5 / 1.5			--	
• Rated impulse withstand voltage in kV / pollution degree	8 / 3				
• Overvoltage category / molded plastic group	III / I				
Conductor cross-section acc. to DIN VDE 0295					
• Core insulation	PVC / PE (other insulation types on request)				
• Solid/finely stranded H05V-U/R/K / H07V-U/R/K in mm <sup>2</sup>	0.5 ... 1.0 / 1.5				
• Halogen-free H05Z-U/R/K / H07Z-U/R/K in mm <sup>2</sup>	0.5 ... 1.0 / 1.5				
• Finely stranded / very finely stranded					
- (Strand Ø ≥ 0.1 mm) in mm <sup>2</sup>	0.25 ... 0.34				
- (Strand Ø ≥ 0.19 mm) AWG	24-16				
Number of circuits					
• At least 100x the same cross-section in mm <sup>2</sup>	0.25 ... 1.5				
Molded plastic type	PA				
• Flammability class acc. to UL 94	VO				
Approval data (UL/cUL and CSA)					
• Rated voltage / rated current / conductor sizes					
- UL/cUL: in V/A / AWG	600 / 10 / 24-16			-- / -- / 24-16	
- CSA: in V/A / AWG	--				
Support rails/protective conductor busbars	--				See section "Support rails" on page 1/3

	8WH3 004-0CE07	8WH3 000-0AF00 8WH3 000-0AF01	8WH3 003-0AF00 8WH3 003-0AF01	8WH3 000-0CF07	8WH3 003-0CF07
Dimensions					
• Width/length/cover width in mm	5.2 / 94 / 2.2	6.2 / 62.6 / 2.2	6.2 / 82.5 / 2.2	6.2 / 62.6 / 2.2	6.2 / 82.5 / 2.2
• Height (TS 35/7.5 / TS 35/15) in mm	39.3 / 46.8		42.8 / 50.3	39.3 / 46.8	42.8 / 50.3
Technical specifications acc. to IEC/DIN VDE					
• Max. load current in A / cross-section in mm <sup>2</sup>	--	24 / 2.5		--	
• Rated impulse withstand voltage in kV / pollution degree	8 / 3				
• Overvoltage category / molded plastic group	III / I				
Conductor cross-section acc. to DIN VDE 0295					
• Core insulation	PVC / PE (other insulation types on request)				
• Solid/finely stranded H05V-U/R/K / H07V-U/R/K in mm <sup>2</sup>	0.5 ... 1.0 / 1.5	0.5 ... 1.5 / 1.5 ... 2.5			
• Halogen-free H05Z-U/R/K / H07Z-U/R/K in mm <sup>2</sup>	0.5 ... 1.0 / 1.5	0.5 ... 1.5 / 1.5 ... 2.5			
• Finely stranded / very finely stranded					
- (Strand Ø ≥ 0.1 mm) in mm <sup>2</sup>	0.25 ... 0.34	--			
- (Strand Ø ≥ 0.19 mm) AWG	24-16	20-14			
Number of circuits					
• At least 100x the same cross-section in mm <sup>2</sup>	0.25 ... 1.5	0.5 ... 2.5			
Molded plastic type	PA				
• Flammability class acc. to UL 94	VO				
Approval data (UL/cUL and CSA)					
• Rated voltage / rated current / conductor sizes					
- UL/cUL: in V/A / AWG	-- / -- / 24-16	Applied for	Applied for		
- CSA: in V/A / AWG	--				
Support rails/protective conductor busbars	See section "Support rails" on page 1/3	--			See section "Support rails" on page 1/3

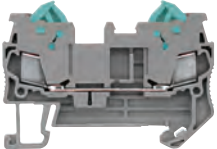
# 8WH3 Insulation Displacement Terminals

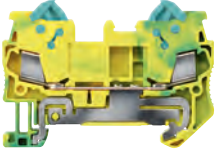
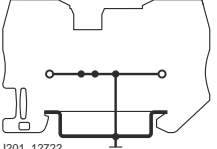

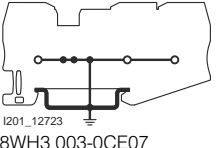

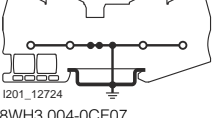
## 8WH through-type terminals

### Selection and ordering data

Version	Order No.	MOQ*
<b>Terminal size 1.5 mm<sup>2</sup></b>		
 <p>8WH3 000-0AE00</p>	<p><b>Through-type terminals, terminal size 1.5 mm<sup>2</sup></b></p> <ul style="list-style-type: none"> <li>Terminal width 5.2 mm</li> <li>Connection data                             <ul style="list-style-type: none"> <li>Rigid 0.25 ... 1.5 mm<sup>2</sup></li> <li>Flexible 0.25 ... 1.5 mm<sup>2</sup></li> <li>AWG 24-16</li> <li>I = 17.5 A</li> <li>U = 800 V</li> </ul> </li> <li>More information, see <a href="#">Technical specifications on page 6/5</a></li> </ul> <p><b>Versions</b></p> <ul style="list-style-type: none"> <li>Gray                             <ul style="list-style-type: none"> <li>Two clamping points</li> <li>Three clamping points</li> <li>Four clamping points</li> </ul> </li> <li>Blue                             <ul style="list-style-type: none"> <li>Two clamping points</li> <li>Three clamping points</li> <li>Four clamping points</li> </ul> </li> </ul> <p><b>Note</b></p> <p>On terminals with three and four clamping points, the total current through all connected conductors must not exceed the max. load current.</p>	<p><b>8WH3 000-0AE00</b> 50 units  <b>8WH3 003-0AE00</b> 50 units  <b>8WH3 004-0AE00</b> 50 units</p> <p><b>8WH3 000-0AE01</b> 50 units  <b>8WH3 003-0AE01</b> 50 units  <b>8WH3 004-0AE01</b> 50 units</p>
 <p>8WH3 003-0AE00</p>		
 <p>8WH3 004-0AE00</p>		
<p><b>PE through-type terminals, terminal size 1.5 mm<sup>2</sup></b></p> <ul style="list-style-type: none"> <li>Green/yellow</li> <li>Terminal width 5.2 mm</li> <li>Connection data                             <ul style="list-style-type: none"> <li>Rigid 0.25 ... 1.5 mm<sup>2</sup></li> <li>Flexible 0.25 ... 1.5 mm<sup>2</sup></li> <li>AWG 24-16</li> </ul> </li> <li>More information, see <a href="#">Technical specifications on page 6/5</a></li> </ul> <p><b>Versions</b></p> <ul style="list-style-type: none"> <li>Two clamping points</li> <li>Three clamping points</li> <li>Four clamping points</li> </ul>		
 <p>8WH3 000-0CE07</p>		
 <p>i201_12722 8WH3 000-0CE07</p>		
 <p>8WH3 003-0CE07</p>		
 <p>i201_12723 8WH3 003-0CE07</p>		
 <p>8WH3 004-0CE07</p>		
 <p>i201_12724 8WH3 004-0CE07</p>		

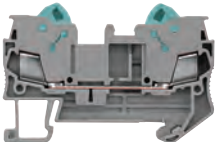
# 8WH3 Insulation Displacement Terminals

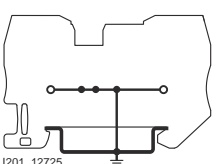
## 8WH through-type terminals

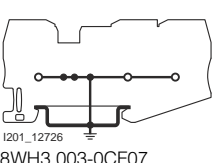



Version	Order No.	MOQ*
<b>Terminal size 2.5 mm<sup>2</sup></b>		
 <p>8WH3 000-0AF00</p>	<p><b>Through-type terminals, terminal size 2.5 mm<sup>2</sup></b></p> <ul style="list-style-type: none"> <li>Terminal width 6.2 mm</li> <li>Connection data                             <ul style="list-style-type: none"> <li>Rigid 0.5 ... 2.5 mm<sup>2</sup></li> <li>Flexible 0.5 ... 2.5 mm<sup>2</sup></li> <li>AWG 20-14</li> <li>I = 24 A</li> <li>U = 800 V</li> </ul> </li> </ul>	
 <p>8WH3 003-0AF00</p>	<p><b>Versions</b></p> <ul style="list-style-type: none"> <li>Gray                             <ul style="list-style-type: none"> <li>Two clamping points</li> <li>Three clamping points</li> </ul> </li> <li>Blue                             <ul style="list-style-type: none"> <li>Two clamping points</li> <li>Three clamping points</li> </ul> </li> </ul>	
<b>Note</b>		
<p>On terminals with three clamping points, the total current through all connected conductors must not exceed the max. load current.</p>		
<p><b>8WH3 000-0AF00</b> <b>8WH3 003-0AF00</b></p> <p>50 units 50 units</p> <p><b>8WH3 000-0AF01</b> <b>8WH3 003-0AF01</b></p> <p>50 units 50 units</p>		
<b>PE through-type terminals, terminal size 2.5 mm<sup>2</sup></b>		
 <p>8WH3 000-0CF07</p>	<p><b>PE through-type terminals, terminal size 2.5 mm<sup>2</sup></b></p> <ul style="list-style-type: none"> <li>Green/yellow</li> <li>Terminal width 6.2 mm</li> <li>Connection data                             <ul style="list-style-type: none"> <li>Rigid 0.5 ... 2.5 mm<sup>2</sup></li> <li>Flexible 0.5 ... 2.5 mm<sup>2</sup></li> <li>AWG 20-14</li> </ul> </li> </ul>	
 <p>1201_12725 8WH3 000-0CF07</p>	<p><b>Versions</b></p> <ul style="list-style-type: none"> <li>Two clamping points</li> <li>Three clamping points</li> </ul>	
 <p>8WH3 003-0CF07</p>		
 <p>1201_12726 8WH3 003-0CF07</p>		
<p><b>8WH3 000-0CF07</b> <b>8WH3 003-0CF07</b></p> <p>50 units 50 units</p>		

\* You can order this quantity or a multiple thereof.

# 8WH3 Insulation Displacement Terminals

## 8WH through-type terminals

6

	Version	Order No.	MOQ*
<b>Accessories</b>			
 8WH9 070-0JA00	<b>Compartment partitions, for terminal size 1.5 to 2.5 mm²</b> <ul style="list-style-type: none"> <li>• For visual and electrical separation of terminal groups</li> <li>• 2 mm thick</li> </ul>	<b>8WH9 070-0JA00</b> <b>8WH9 070-0KA00</b>	50 units 50 units
	Versions <ul style="list-style-type: none"> <li>• Two clamping points</li> <li>• Three clamping points</li> </ul>		
 8WH9 070-0LA00	<b>Compartment partitions, for terminal size 1.5 mm² and four connection points</b>	<b>8WH9 070-0LA00</b>	50 units
 8WH9 001-1AA00	<b>Covers, for terminal size 1.5 mm²</b> Gray	<b>8WH9 001-1AA00</b> <b>8WH9 001-2AA00</b> <b>8WH9 001-4AA00</b>	50 units 50 units 50 units
	Versions <ul style="list-style-type: none"> <li>• Two clamping points</li> <li>• Three clamping points</li> <li>• Four clamping points</li> </ul>		
 8WH9 000-1AA00	<b>Covers, for terminal size 2.5 mm²</b> Gray	<b>8WH9 000-1AA00</b> <b>8WH9 000-2AA00</b>	50 units 50 units
	Versions <ul style="list-style-type: none"> <li>• Two clamping points</li> <li>• Three clamping points</li> </ul>		
 8WH9 001-0AA00	<b>Cover segments, for three or four clamping points</b> <ul style="list-style-type: none"> <li>• Gray</li> <li>• For covering multi-wire terminals when mounting two-wire terminals side-by-side</li> </ul>	<b>8WH9 001-0AA00</b> <b>8WH9 000-0AA00</b>	50 units 50 units
	Versions <ul style="list-style-type: none"> <li>• For terminal size 1.5 mm²</li> <li>• For terminal size 2.5 mm²</li> </ul>		

Note:

For general accessories for 8WH terminal blocks, [see chapter 8](#).

### Overview

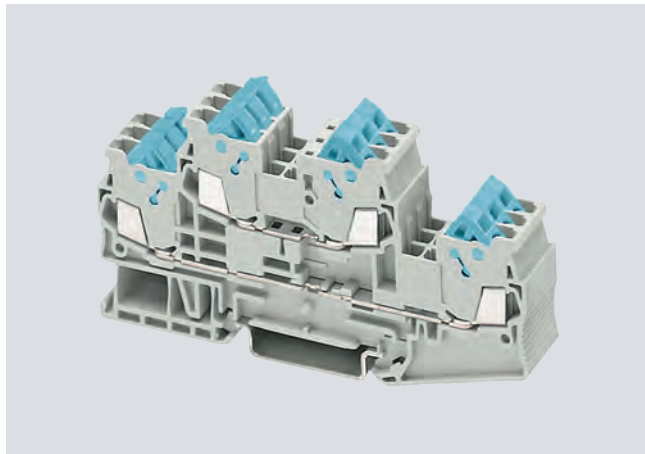

Key features of the IDC two-tier terminals for terminal size 1.5 mm<sup>2</sup> are their ultra compact design and the double bridge shaft for each tier. This enables simultaneous bridging and testing.

With its clear and space-saving front connection arrangement, this two-tier terminal series provides additional space between the cable ducts for wiring.

The PE/ground conductor terminal of this range meets all the requirements of IEC 60 947-7-2.

These include:

- Low contact resistance
- Stainless clamping points and PE mounting foot
- Green-yellow enclosure and
- Additional inscription options.

The clamping points of two-tier terminals can be inscribed with flat labels.





### Technical specifications

	8WH3 020-0AE00 8WH3 020-0AE01	8WH3 020-0CE07
Dimensions		
• Width/length/cover width in mm	5.2 / 99,6 / 2.2	
• Height (TS 35/7.5 / TS 35/15) in mm	49.9 / 57.4	
Technical specifications acc. to IEC/DIN VDE		
• Max. load current in A / cross-section in mm <sup>2</sup>	17.5 / 1.5	--
• Rated impulse withstand voltage in kV / pollution degree	6 / 3	
• Overvoltage category / molded plastic group	III / I	
Conductor cross-section acc. to DIN VDE 0295		
• Core insulation	PVC / PE (other insulation types on request)	
• Solid/finely stranded H05V-U/R/K / H07V-U/R/K in mm <sup>2</sup>	0.4 ... 1.0 / 1.5	
• Halogen-free H05Z-U/R/K / H07Z-U/R/K in mm <sup>2</sup>	0.5 ... 1.0 / 1.5	
• Finely stranded / very finely stranded		
- (Strand Ø ≥ 0.1 mm) in mm <sup>2</sup>	0.25 ... 0.34	
- (Strand Ø ≥ 0.19 mm) AWG	24-16	
Number of circuits		
• At least 100x the same cross-section in mm <sup>2</sup>	0.25 ... 1.5	
Molded plastic type	PA	
• Flammability class acc. to UL 94	V0	
Approval data (UL/cUL and CSA)		
• Rated voltage / rated current / conductor sizes		
- UL/cUL: in V/A / AWG	600 / 10 / 24-16	-- / -- / 24-16
- CSA: in V/A / AWG	--	
Support rails/protective conductor busbars	--	See section "Support rails" on page 1/3

# 8WH3 Insulation Displacement Terminals

## 8WH two-tier terminals

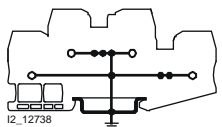
### Selection and ordering data

Version	Order No.	MOQ*
<b>Terminal size 1.5 mm<sup>2</sup></b>		
 <p>8WH3 020-0AE00</p> <p><b>Two-tier terminals, terminal size 1.5 mm<sup>2</sup></b></p> <ul style="list-style-type: none"> <li>Terminal width 5.2 mm</li> <li>CECULus</li> <li>Connection data                             <ul style="list-style-type: none"> <li>Rigid 0.25 ... 1.5 mm<sup>2</sup></li> <li>Flexible 0.25 ... 1.5</li> <li>AWG 24-16</li> <li>I = 17.5 A</li> <li>U = 500 V</li> </ul> </li> <li>More information, see <a href="#">Technical specifications on page 6/5</a></li> </ul> <p>Versions</p> <ul style="list-style-type: none"> <li>Gray</li> <li>Blue</li> </ul>	<p><b>8WH3 020-0AE00</b></p> <p><b>8WH3 020-0AE01</b></p>	<p>50 units</p> <p>50 units</p>
 <p>8WH3 020-0CE07</p> <p><b>PE two-tier terminals, terminal size 1.5 mm<sup>2</sup></b></p> <ul style="list-style-type: none"> <li>Green/yellow</li> <li>Terminal width 5.2 mm</li> <li>CECULus</li> <li>Connection data                             <ul style="list-style-type: none"> <li>Rigid 0.25 ... 1.5 mm<sup>2</sup></li> <li>Flexible 0.25 ... 1.5</li> <li>AWG 24-16</li> </ul> </li> <li>More information, see <a href="#">Technical specifications on page 6/5</a></li> </ul>  <p>12_12738</p> <p>8WH3 020-0CE07</p>	<p><b>8WH3 020-0CE07</b></p>	<p>50 units</p>
<b>Accessories</b>		
 <p>8WH9 070-0MA00</p> <p><b>Compartment partitions, for terminal size 1.5 mm<sup>2</sup></b></p>	<p><b>8WH9 070-0MA00</b></p>	<p>50 units</p>
 <p>8WH9 001-1BA00</p> <p><b>Covers, for terminal size 1.5 mm<sup>2</sup></b></p>	<p><b>8WH9 001-1BA00</b></p>	<p>50 units</p>

Note:

For general accessories for 8WH terminal blocks, see [chapter 8](#).

### Overview

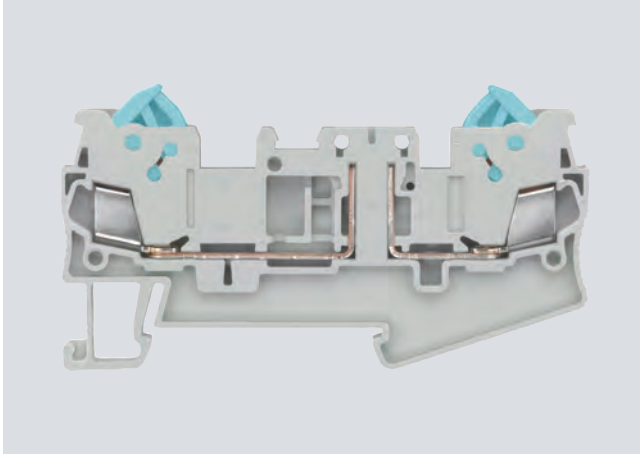

8WH3 isolating terminals using insulation displacement technology are available for special wiring tasks. Numerous wiring tasks can be performed on a terminal width of 5.2 mm by integrating the isolated through-type connector, the isolating plug, the component connector or the fused plug.

A label can be snapped on to the middle of each terminal at the front. Further labels can also be mounted flat on the side of the terminals.

### Technical specifications

	8WH3 000-6AE00	8WH3 000-6AF00
Dimensions		
• Width/length/cover width in mm	5.2 / 76.4 / 2.2	6.2 / 82.5 / 2.2
• Height (TS 35/7.5 / TS 35/15) in mm	39.3 / 46.8	42.8 / 50.3
Technical specifications acc. to IEC/DIN VDE		
• Max. load current in A / cross-section in mm <sup>2</sup>	16 / 1.5	16 / 2.5
• Rated impulse withstand voltage in kV / pollution degree	6 / 3	
• Overvoltage category / molded plastic group	III / I	
Conductor cross-section acc. to DIN VDE 0295		
• Core insulation	PVC / PE (other insulation types on request)	
• Solid/finely stranded H05V-U/R/K / H07V-U/R/K in mm <sup>2</sup>	0.5 ... 1.0 / 1.5	0.5 ... 1.0 / 1.5 ... 2.5
• Halogen-free H05Z-U/R/K / H07Z-U/R/K in mm <sup>2</sup>	0.5 ... 1.0 / 1.5	0.5 ... 1.0 / 1.5 ... 2.5
• Finely stranded / very finely stranded		
- (Strand Ø ≥ 0.1 mm) in mm <sup>2</sup>	0.25 ... 0.34	--
- (Strand Ø ≥ 0.19 mm) AWG	24-16	20-14
Number of circuits		
• At least 100x the same cross-section in mm <sup>2</sup>	0.25 ... 1.5	0.5 ... 2.5
Molded plastic type	PA	
• Flammability class acc. to UL 94	V0	
Approval data (UL/cUL and CSA)		
• Rated voltage / rated current / conductor sizes		
- UL/cUL: in V/A / AWG	600 / 10 / 24-16	Applied for
- CSA: in V/A / AWG	600 / 10 / 24-16	Applied for

### Selection and ordering data

Version	Order No.	MOQ*
---------	-----------	------

#### Terminal size 1.5 mm<sup>2</sup>

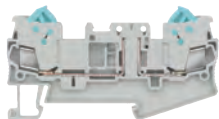

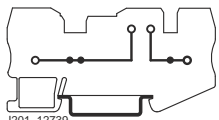

8WH3 000-6AE00



8WH3 000-6AE00

#### Isolating terminals, terminal size 1.5 mm<sup>2</sup>

- Gray
- Terminal width 5.2 mm
-   US
- Connection data
  - Rigid 0.25 ... 1.5 mm<sup>2</sup>
  - Flexible 0.25 ... 1.5 mm<sup>2</sup>
  - AWG 24-16
  - I = 16 A
  - U = 400 V
  - Current and voltage are determined by the fitted plug
- More information, see [Technical specifications on page 6/5](#)

#### 8WH3 000-6AE00





50 units

\* You can order this quantity or a multiple thereof.

# 8WH3 Insulation Displacement Terminals

## 8WH isolating terminals

6

	Version	Order No.	MOQ*
<b>Terminal size 2.5 mm<sup>2</sup></b>			
 <p>8WH3 000-6AF00</p>	<p><b>Isolating terminals, terminal size 2.5 mm<sup>2</sup></b></p> <ul style="list-style-type: none"> <li>• Gray</li> <li>• Terminal width 6.2 mm</li> <li>• Connection data                             <ul style="list-style-type: none"> <li>- Rigid 0.5 ... 2.5 mm<sup>2</sup></li> <li>- Flexible 0.5 ... 2.5 mm<sup>2</sup></li> <li>- AWG 20-14</li> <li>- I = 16 A</li> <li>- U = 400 V</li> </ul> </li> <li>• Current and voltage are determined by the fitted plug</li> <li>• More information, see <a href="#">Technical specifications on page 6/5</a></li> </ul>	<b>8WH3 000-6AF00</b>	50 units
<b>Accessories</b>			
 <p>8WH9 070-0KA00</p>	<p><b>Compartment partitions, for terminal size 1.5 to 2.5 mm<sup>2</sup> and three clamping points</b></p>	<b>8WH9 070-0KA00</b>	50 units
 <p>8WH9 001-2AA00</p>	<p><b>Covers</b></p> <p>Versions</p> <ul style="list-style-type: none"> <li>• For terminal size 1.5 mm<sup>2</sup> and three clamping points</li> <li>• For terminal size 2.5 mm<sup>2</sup> and three clamping points</li> </ul>	<p><b>8WH9 001-2AA00</b></p> <p><b>8WH9 000-2AA00</b></p>	<p>50 units</p> <p>50 units</p>
 <p>8WH9 001-0AA00</p>	<p><b>Cover segments</b></p> <p>Versions</p> <ul style="list-style-type: none"> <li>• For terminal size 1.5 mm<sup>2</sup> and three or four clamping points</li> <li>• For terminal size 2.5 mm<sup>2</sup> and three or four clamping points</li> </ul>	<p><b>8WH9 001-0AA00</b></p> <p><b>8WH9 000-0AA00</b></p>	<p>50 units</p> <p>50 units</p>

Note:

For general accessories for 8WH terminal blocks, see [chapter 8](#).

# 8WH1 Screw Terminals



7/2	<b>Introduction</b>
7/3	<b>General data on 8WH</b>
7/4	<b>8WH through-type terminals<sup>1)</sup></b>
7/8	<b>8WH fuse terminals</b>
7/10	<b>8WH isolating blade terminals</b>
7/11	<b>8WH isolating terminals</b>
7/12	<b>8WH two-tier terminals<sup>1)</sup></b>
7/15	<b>8WH two-tier terminals with isolating function/isolating blade</b>
7/17	<b>8WH diode terminals</b>
7/18	<b>8WH two-tier diode terminals</b>
7/20	<b>8WH high-current terminals<sup>1)</sup></b>
7/24	<b>8WH shield terminals</b>

<sup>1)</sup> Also available as a PE version

## More technical product information:

Service&Support Portal:  
[www.support.automation.siemens.com](http://www.support.automation.siemens.com)





Product List:  
Technical specifications

Entry List:  
Updates / Downloads / FAQ /  
Manuals / Operating instructions /  
Characteristic curves / Certificates

# 8WH1 Screw Terminals

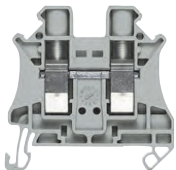
## Introduction

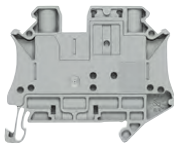
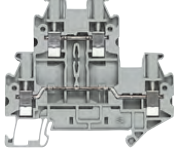
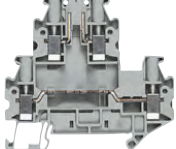
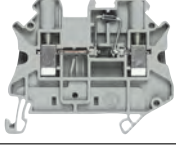
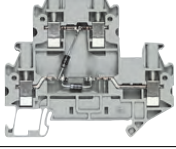
### Overview

	Devices	Page	Function
	Through-type terminals	7/4	Connection of incoming and outgoing conductors up to 35 mm <sup>2</sup>
	Fuse terminals	7/8	Terminals which can be used to protect control circuits, for example
	Isolating blade terminals	7/10	Isolation of the circuit, e.g. for test purposes
	Isolating terminals	7/11	Isolation of the circuit, e.g. for test purposes
	Two-tier terminals	7/12	Compact form of the terminal block in which two connection wires can be installed
	Two-tier terminals with isolating function	7/15	Compact form of the terminal block in which two connection wires can be installed
	Diode terminals	7/17	Terminal blocks with integrated diodes
	Two-tier diode terminals	7/18	Terminal blocks with integrated diodes
	8WH high-current terminals	7/20	Connection of incoming and outgoing cables from 50 to 240 mm <sup>2</sup>
	8WH shield terminals	7/24	Terminals for connection of shielded cables

### Overview

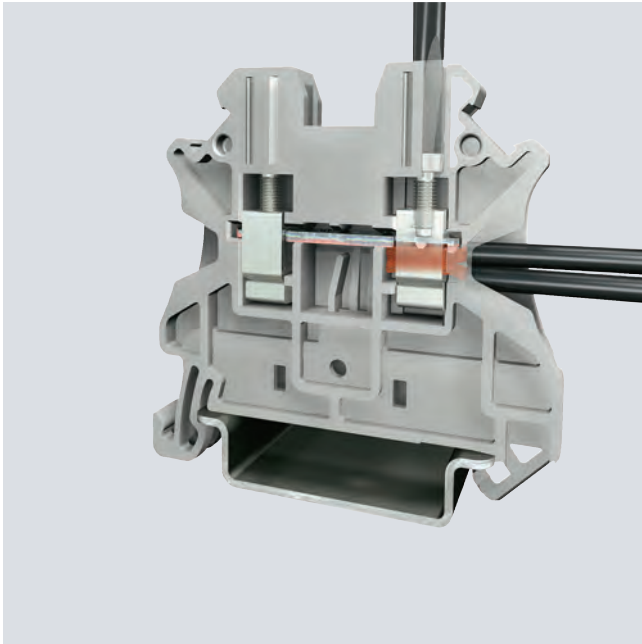

The screw terminal is characterized by its global standard, multi-conductor connection and maintenance-free design.

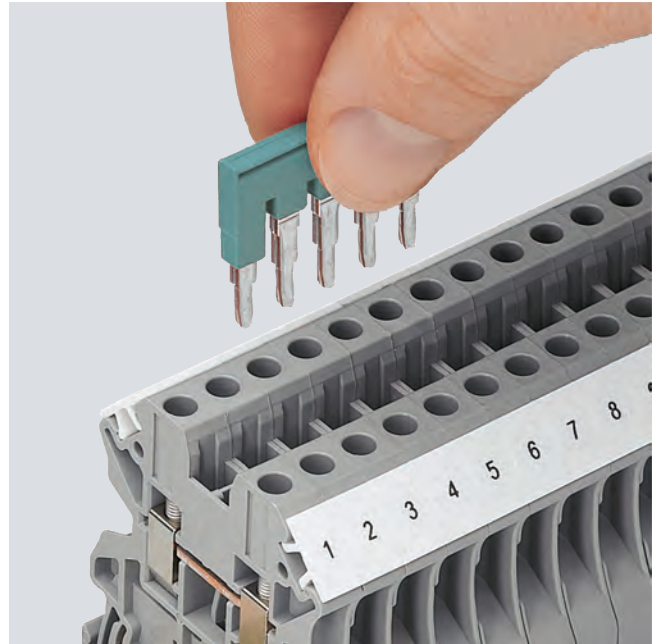

The potential distribution can be quickly implemented with the standardized connecting combs. Flexible chain bridging, level bridging, or skipping of several terminals are possible through two or more bridge shafts in all the terminals.

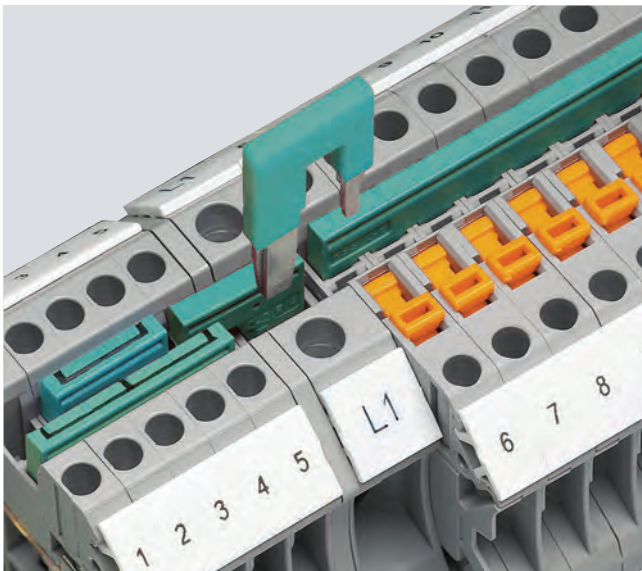

Reducing combs enable easy connection of terminals with various nominal cross-sections and terminal designs. Reducing combs can be used for the quick assembly of infeed blocks.

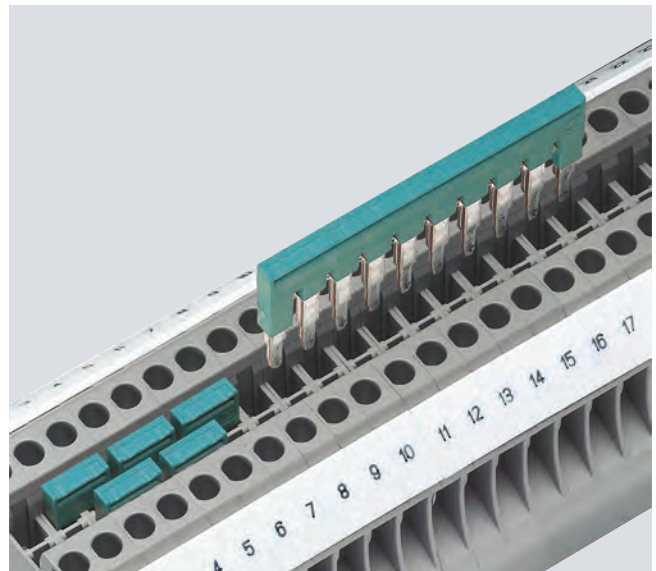

The double bridge shaft enables an assembly of any number of terminals with two-pole jumpers. The 2-pole to 50-pole jumpers enable up to 50 terminals to be connected in a single step.

# 8WH1 Screw Terminals

## 8WH through-type terminals

### Overview

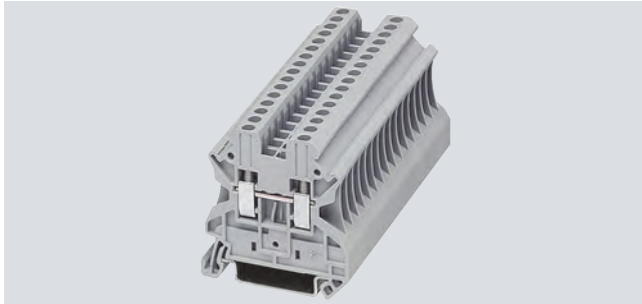







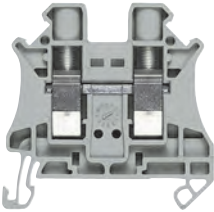

8WH through-type terminals are characterized by their compact design and optimum handling. They are available in conductor cross-section areas from 2.5 to 35 mm<sup>2</sup> and can be inscribed with labels. The double bridge shaft enables individual chain bridging by means of standard connecting combs. Corresponding accessories are available for testing and labeling. Secure electrical and mechanical contact with the support rail is established by simply snapping the terminals onto the rail.

The individual clamping points can be inscribed at the front using the labels.

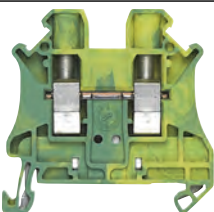
### Technical specifications

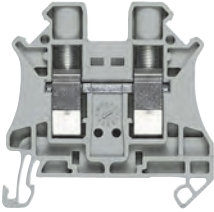
	8WH1 000-0AF00 8WH1 000-0AF01	8WH1 000-0AG00 8WH1 000-0AG01	8WH1 000-0AH00 8WH1 000-0AH01	8WH1 000-0AJ00 8WH1 000-0AJ01	8WH1 000-0AK00 8WH1 000-0AK01	8WH1 000-0AM00 8WH1 000-0AM01
Dimensions						
• Width/length/cover width in mm	5.2 / 47.7 / 2.2	6.2 / 47.7 / 2.2	8.2 / 47.7 / 2.2	10.2 / 47.7 / 2.2	12 / 55.3 / 2.2	16 / 60.2 / --
• Height (NS 35/7.5 / NS 35/15) in mm	47.5 / 55				55 / 62.5	65.7 / 73.2
Technical specifications acc. to IEC/DIN VDE						
• Max. load current in A / cross-section in mm <sup>2</sup>	32 / 4	41 / 6	57 / 10	76 / 16	101 / 25	150 / 50
• Rated impulse withstand voltage in kV / pollution degree	8 kV / 3					
• Rated insulation voltage (working voltage) U <sub>i</sub> in V acc. to IEC 60497-7-1	1000					
• Overvoltage category / molded plastic group	III / I					
Connection capacities						
• Flexible with end sleeve, with plastic sleeve in mm <sup>2</sup>	0.25 ... 2.5	0.25 ... 4	0.25 ... 6	0.5 ... 10	1.0 ... 16	1.5 ... 35
• Flexible with end sleeve, without plastic sleeve in mm <sup>2</sup>	0.25 ... 2.5	0.25 ... 4	0.25 ... 6	0.5 ... 10	1.0 ... 16	1.5 ... 35
• Flexible with two-wire connection end sleeve, with plastic sleeve in mm <sup>2</sup>	0.5 ... 1.5	0.5 ... 2.5	0.5 ... 4	0.5 ... 6	0.75 ... 10	1.5 ... 10
• Rigid in mm <sup>2</sup>	0.14 ... 4	0.14 ... 6	0.2 ... 10	0.5 ... 16	1.5 ... 25	1.5 ... 50
Stripped length in mm	9		10		14	18
Tightening torque in Nm	0.6 ... 0.8		1.5 ... 1.8		2.5 ... 3.0	3.2 ... 3.7
Molded plastic type	PA					
• Flammability class acc. to UL 94	V0					
Approval data (UL/cUL and CSA)						
• Rated voltage / rated current / conductor sizes						
- UL/cUL: in V/A / AWG	600 / 20 / 26-12	600 / 30 / 26-10	600 / 50 / 24-8	600 / 65 / 20-6	600 / 85 / 16-4	600 / 150 / 14-1/0
- CSA: in V/A / AWG	600 / 20 / 26-12	600 / 30 / 26-10	600 / 50 / 24-8	600 / 65 / 20-6	600 / 85 / 16-4	600 / 150 / 14-1/0
	<b>8WH1 000-0CF07</b>	<b>8WH1 000-0CG07</b>	<b>8WH1 000-0CH07</b>	<b>8WH1 000-0CJ07</b>	<b>8WH1 000-0CK07</b>	<b>8WH1 000-0CM07</b>
Dimensions						
• Width/length/cover width in mm	5.2 / 47.7 / 2.2	6.2 / 47.7 / 2.2	8.2 / 47.7 / 2.2	10.2 / 47.7 / 2.2	12 / 55.3 / 2.2	16 / 60.2 / --
• Height (NS 35/7.5 / NS 35/15) in mm	47.5 / 55				55 / 62.5	65.7 / 73.2
Technical specifications acc. to IEC/DIN VDE						
• Max. load current in A / cross-section in mm <sup>2</sup>	-- / 4	-- / 6	-- / 10	-- / 16	101 / 25	125 / 35
• Rated impulse withstand voltage in kV / pollution degree	8 kV / 3					
• Overvoltage category / molded plastic group	III / I					
Connection capacities						
• Flexible with end sleeve, with plastic sleeve in mm <sup>2</sup>	0.25 ... 2.5	0.25 ... 2.4	0.25 ... 6	0.5 ... 10	1.0 ... 16	1.5 ... 35
• Flexible with end sleeve, without plastic sleeve in mm <sup>2</sup>	0.25 ... 2.5	0.25 ... 2.4	0.25 ... 6	0.5 ... 10	1.0 ... 16	1.5 ... 35
• Flexible with two-wire connection end sleeve, with plastic sleeve in mm <sup>2</sup>	0.5 ... 1.5	0.5 ... 2.5	0.5 ... 4	0.5 ... 6	0.75 ... 10	1.5 ... 10
• Rigid in mm <sup>2</sup>	0.14 ... 4	0.14 ... 6	0.2 ... 10	0.5 ... 16	1.5 ... 25	1.5 ... 35
Stripped length in mm	9		10		14	18
Tightening torque in Nm	0.6 ... 0.8		1.6 ... 1.8	1.5 ... 1.8	2.5 ... 3.0	3.2 ... 3.7
Molded plastic type	PA					
• Flammability class acc. to UL 94	V0					
Approval data (UL/cUL and CSA)						
• Rated voltage / rated current / conductor sizes						
- UL/cUL: in V/A / AWG	-- / -- / 26-12	-- / -- / 26-10	-- / -- / 24-8	-- / -- / 20-6	-- / -- / 16-4	-- / -- / 14-1/0
- CSA: in V/A / AWG	-- / -- / 26-12	-- / -- / 26-10	-- / -- / 24-8	-- / -- / 20-6	-- / -- / 16-4	-- / -- / 14-1/0

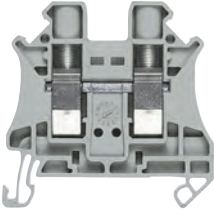
### Selection and ordering data









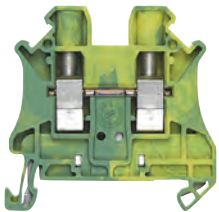

Version	Order No.	MOQ*
<b>Terminal size 2.5 mm<sup>2</sup></b>		
 <p>8WH1 000-0AF00</p> <p><b>Through-type terminals, terminal size 2.5 mm<sup>2</sup></b></p> <ul style="list-style-type: none"> <li>•  US</li> <li>• Terminal width 5.2 mm</li> <li>• <math>I_{max} = 32</math> A</li> <li>• <math>U_{max} = 1000</math> V</li> <li>• AWG 26-12</li> <li>• Connection capacity, one conductor                     <ul style="list-style-type: none"> <li>- Rigid 0.14 ... 4 mm<sup>2</sup></li> <li>- Flexible 0.14 ... 4 mm<sup>2</sup></li> </ul> </li> <li>• Connection capacity, two conductors                     <ul style="list-style-type: none"> <li>- Rigid 0.14 ... 1.5 mm<sup>2</sup></li> <li>- Flexible 0.14 ... 1.5 mm<sup>2</sup></li> </ul> </li> </ul> <p>Versions</p> <ul style="list-style-type: none"> <li>• Gray</li> <li>• Blue</li> </ul>	<p><b>8WH1 000-0AF00</b></p> <p><b>8WH1 000-0AF01</b></p>	<p>50 units</p> <p>50 units</p>
 <p>8WH1 000-0CF07</p> <p><b>PE through-type terminals, terminal size 2.5 mm<sup>2</sup></b></p> <ul style="list-style-type: none"> <li>•  US</li> <li>• Terminal width 5.2 mm</li> <li>• AWG 26-12</li> <li>• Connection capacity, one conductor                     <ul style="list-style-type: none"> <li>- Rigid 0.14 ... 4 mm<sup>2</sup></li> <li>- Flexible 0.14 ... 4 mm<sup>2</sup></li> </ul> </li> <li>• Connection capacity, two conductors                     <ul style="list-style-type: none"> <li>- Rigid 0.14 ... 1.5 mm<sup>2</sup></li> <li>- Flexible 0.14 ... 1.5 mm<sup>2</sup></li> </ul> </li> <li>• Green/yellow</li> </ul>	<p><b>8WH1 000-0CF07</b></p>	<p>50 units</p>
<b>Terminal size 4 mm<sup>2</sup></b>		
 <p>8WH1 000-0AG00</p> <p><b>Through-type terminals, terminal size 4 mm<sup>2</sup></b></p> <ul style="list-style-type: none"> <li>•  US</li> <li>• Terminal width 6.2 mm</li> <li>• <math>I_{max} = 41</math> A</li> <li>• <math>U_{max} = 1000</math> V</li> <li>• AWG 26-10</li> <li>• Connection capacity, one conductor                     <ul style="list-style-type: none"> <li>- Rigid 0.14 ... 6 mm<sup>2</sup></li> <li>- Flexible 0.14 ... 6 mm<sup>2</sup></li> </ul> </li> <li>• Connection capacity, two conductors                     <ul style="list-style-type: none"> <li>- Rigid 0.14 ... 1.5 mm<sup>2</sup></li> <li>- Flexible 0.14 ... 1.5 mm<sup>2</sup></li> </ul> </li> </ul> <p>Versions</p> <ul style="list-style-type: none"> <li>• Gray</li> <li>• Blue</li> </ul>	<p><b>8WH1 000-0AG00</b></p> <p><b>8WH1 000-0AG01</b></p>	<p>50 units</p> <p>50 units</p>
 <p>8WH1 000-0CG07</p> <p><b>PE through-type terminals, terminal size 4 mm<sup>2</sup></b></p> <ul style="list-style-type: none"> <li>•  US</li> <li>• Terminal width 6.2 mm</li> <li>• AWG 26-10</li> <li>• Connection capacity, one conductor                     <ul style="list-style-type: none"> <li>- Rigid 0.14 ... 6 mm<sup>2</sup></li> <li>- Flexible 0.14 ... 6 mm<sup>2</sup></li> </ul> </li> <li>• Connection capacity, two conductors                     <ul style="list-style-type: none"> <li>- Rigid 0.14 ... 1.5 mm<sup>2</sup></li> <li>- Flexible 0.14 ... 1.5 mm<sup>2</sup></li> </ul> </li> <li>• Green/yellow</li> </ul>	<p><b>8WH1 000-0CG07</b></p>	<p>50 units</p>
<b>Terminal size 6 mm<sup>2</sup></b>		
 <p>8WH1 000-0AH00</p> <p><b>Through-type terminals, terminal size 6 mm<sup>2</sup></b></p> <ul style="list-style-type: none"> <li>•  US</li> <li>• Terminal width 8.2 mm</li> <li>• <math>I_{max} = 57</math> A</li> <li>• <math>U_{max} = 1000</math> V</li> <li>• AWG 24-8</li> <li>• Connection capacity, one conductor                     <ul style="list-style-type: none"> <li>- Rigid 0.2 ... 10 mm<sup>2</sup></li> <li>- Flexible 0.2 ... 10 mm<sup>2</sup></li> </ul> </li> <li>• Connection capacity, two conductors                     <ul style="list-style-type: none"> <li>- Rigid 0.2 ... 2.5 mm<sup>2</sup></li> <li>- Flexible 0.2 ... 2.5 mm<sup>2</sup></li> </ul> </li> </ul> <p>Versions</p> <ul style="list-style-type: none"> <li>• Gray</li> <li>• Blue</li> </ul>	<p><b>8WH1 000-0AH00</b></p> <p><b>8WH1 000-0AH01</b></p>	<p>50 units</p> <p>50 units</p>

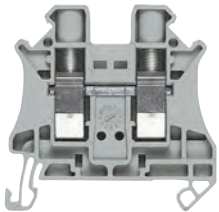
\* You can order this quantity or a multiple thereof.

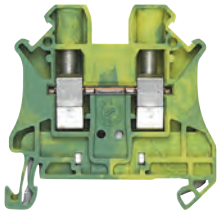

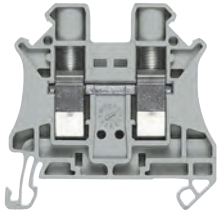

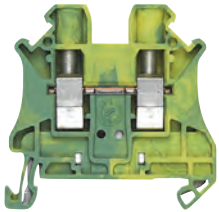

# 8WH1 Screw Terminals

## 8WH through-type terminals

7

Version	Order No.	MOQ*												
 <p>8WH1 000-0CH07</p> <p><b>PE through-type terminals, terminal size 6 mm<sup>2</sup></b></p> <ul style="list-style-type: none"> <li>•   US</li> <li>• Terminal width 8.2 mm</li> <li>• AWG 24-8</li> <li>• Connection capacity, one conductor <ul style="list-style-type: none"> <li>- Rigid 0.2 ... 10 mm<sup>2</sup></li> <li>- Flexible 0.2 ... 10 mm<sup>2</sup></li> </ul> </li> <li>• Connection capacity, two conductors <ul style="list-style-type: none"> <li>- Rigid 0.2 ... 2.5 mm<sup>2</sup></li> <li>- Flexible 0.2 ... 2.5 mm<sup>2</sup></li> </ul> </li> <li>• Green/yellow</li> </ul> <table border="1"> <thead> <tr> <th>Accessories</th> <th>Section</th> <th>Page</th> </tr> </thead> <tbody> <tr> <td>• Covers, for through-type terminals, for terminal size 2.5 ... 10 mm<sup>2</sup></td> <td>Accessories</td> <td>7/7</td> </tr> <tr> <td>• Compartment partitions, for through-type terminals, for terminal size 2.5 ... 10 mm<sup>2</sup></td> <td>dto.</td> <td>7/7</td> </tr> <tr> <td>• Warning covers, for terminal size 6 mm<sup>2</sup></td> <td>dto.</td> <td>7/7</td> </tr> </tbody> </table>	Accessories	Section	Page	• Covers, for through-type terminals, for terminal size 2.5 ... 10 mm <sup>2</sup>	Accessories	7/7	• Compartment partitions, for through-type terminals, for terminal size 2.5 ... 10 mm <sup>2</sup>	dto.	7/7	• Warning covers, for terminal size 6 mm <sup>2</sup>	dto.	7/7	<b>8WH1 000-0CH07</b>	50 units
Accessories	Section	Page												
• Covers, for through-type terminals, for terminal size 2.5 ... 10 mm <sup>2</sup>	Accessories	7/7												
• Compartment partitions, for through-type terminals, for terminal size 2.5 ... 10 mm <sup>2</sup>	dto.	7/7												
• Warning covers, for terminal size 6 mm <sup>2</sup>	dto.	7/7												
<b>Terminal size 10 mm<sup>2</sup></b>														
 <p>8WH1 000-0AJ00</p> <p><b>Through-type terminals, terminal size 10 mm<sup>2</sup></b></p> <ul style="list-style-type: none"> <li>•   US</li> <li>• Terminal width 10.2 mm</li> <li>• <math>I_{max} = 76</math> A</li> <li>• <math>U_{max} = 1000</math> V</li> <li>• AWG 20-6</li> <li>• Connection capacity, one conductor <ul style="list-style-type: none"> <li>- Rigid 0.5 ... 16 mm<sup>2</sup></li> <li>- Flexible 0.5 ... 16 mm<sup>2</sup></li> </ul> </li> <li>• Connection capacity, two conductors <ul style="list-style-type: none"> <li>- Rigid 0.5 ... 4 mm<sup>2</sup></li> <li>- Flexible 0.5 ... 4 mm<sup>2</sup></li> </ul> </li> </ul> <table border="1"> <thead> <tr> <th>Versions</th> </tr> </thead> <tbody> <tr> <td>• Gray</td> </tr> <tr> <td>• Blue</td> </tr> </tbody> </table>	Versions	• Gray	• Blue											
Versions														
• Gray														
• Blue														
 <p>8WH1 000-0CJ07</p> <p><b>PE through-type terminals, terminal size 10 mm<sup>2</sup></b></p> <ul style="list-style-type: none"> <li>•   US</li> <li>• Terminal width 10.2 mm</li> <li>• AWG 20-6</li> <li>• Connection capacity, one conductor <ul style="list-style-type: none"> <li>- Rigid 0.5 ... 16 mm<sup>2</sup></li> <li>- Flexible 0.5 ... 16 mm<sup>2</sup></li> </ul> </li> <li>• Connection capacity, two conductors <ul style="list-style-type: none"> <li>- Rigid 0.5 ... 4 mm<sup>2</sup></li> <li>- Flexible 0.5 ... 4 mm<sup>2</sup></li> </ul> </li> <li>• Green/yellow</li> </ul>	<b>8WH1 000-0AJ00</b> <b>8WH1 000-0AJ01</b> <b>8WH1 000-0CJ07</b>	50 units 50 units 50 units												
<b>Terminal size 16 mm<sup>2</sup></b>														
 <p>8WH1 000-0AK00</p> <p><b>Through-type terminals, terminal size 16 mm<sup>2</sup></b></p> <ul style="list-style-type: none"> <li>•   US</li> <li>• Terminal width 12.2 mm</li> <li>• <math>I_{max} = 101</math> A</li> <li>• <math>U_{max} = 1000</math> V</li> <li>• AWG 16-4</li> <li>• Connection capacity, one conductor <ul style="list-style-type: none"> <li>- Rigid 1.5 ... 25 mm<sup>2</sup></li> <li>- Flexible 1.5 ... 25 mm<sup>2</sup></li> </ul> </li> <li>• Connection capacity, two conductors <ul style="list-style-type: none"> <li>- Rigid 1 ... 6 mm<sup>2</sup></li> <li>- Flexible 1 ... 6 mm<sup>2</sup></li> </ul> </li> </ul> <table border="1"> <thead> <tr> <th>Versions</th> </tr> </thead> <tbody> <tr> <td>• Gray</td> </tr> <tr> <td>• Blue</td> </tr> </tbody> </table>	Versions	• Gray	• Blue											
Versions														
• Gray														
• Blue														
 <p>8WH1 000-0CK07</p> <p><b>PE through-type terminals, terminal size 16 mm<sup>2</sup></b></p> <ul style="list-style-type: none"> <li>•   US</li> <li>• Terminal width 12.2 mm</li> <li>• AWG 16-4</li> <li>• Connection capacity, one conductor <ul style="list-style-type: none"> <li>- Rigid 1.5 ... 25 mm<sup>2</sup></li> <li>- Flexible 1.5 ... 25 mm<sup>2</sup></li> </ul> </li> <li>• Connection capacity, two conductors <ul style="list-style-type: none"> <li>- Rigid 1 ... 6 mm<sup>2</sup></li> <li>- Flexible 1 ... 6 mm<sup>2</sup></li> </ul> </li> <li>• Green/yellow</li> </ul>	<b>8WH1 000-0AK00</b> <b>8WH1 000-0AK01</b> <b>8WH1 000-0CK07</b>	50 units 50 units 50 units												

\* You can order this quantity or a multiple thereof.

Version	Order No.	MOQ*
<b>Terminal size 35 mm<sup>2</sup></b>		
 <p>8WH1 000-0AM00</p>	<p><b>Through-type terminals, terminal size 35 mm<sup>2</sup></b></p> <ul style="list-style-type: none"> <li>•  US</li> <li>• Terminal width 16 mm</li> <li>• <math>I_{max} = 150</math> A</li> <li>• <math>U_{max} = 1000</math> V</li> <li>• AWG 16-1/0</li> <li>• Connection capacity, one conductor                     <ul style="list-style-type: none"> <li>- Rigid 1.5 ... 50 mm<sup>2</sup></li> <li>- Flexible 1.5 ... 50 mm<sup>2</sup></li> </ul> </li> <li>• Connection capacity, two conductors                     <ul style="list-style-type: none"> <li>- Rigid 1.5 ... 16 mm<sup>2</sup></li> <li>- Flexible 1.5 ... 10 mm<sup>2</sup></li> </ul> </li> <li>• Enclosed at both ends</li> </ul> <p>Versions</p> <ul style="list-style-type: none"> <li>• Gray</li> <li>• Blue</li> </ul>	<p>8WH1 000-0AM00 50 units</p> <p>8WH1 000-0AM01 50 units</p>
 <p>8WH1 000-0CM07</p>	<p><b>PE through-type terminals, terminal size 35 mm<sup>2</sup></b></p> <ul style="list-style-type: none"> <li>•  US</li> <li>• Terminal width 16 mm</li> <li>• AWG 16-2</li> <li>• Connection capacity, one conductor                     <ul style="list-style-type: none"> <li>- Rigid 1.5 ... 35 mm<sup>2</sup></li> <li>- Flexible 1.5 ... 35 mm<sup>2</sup></li> </ul> </li> <li>• Connection capacity, two conductors                     <ul style="list-style-type: none"> <li>- Rigid 1.5 ... 16 mm<sup>2</sup></li> <li>- Flexible 1.5 ... 10 mm<sup>2</sup></li> </ul> </li> <li>• Enclosed at both ends</li> <li>• Green/yellow</li> </ul>	
<b>Accessories</b>		
 <p>8WH9 000-1PA00</p>	<p><b>Covers, for through-type terminals</b></p> <ul style="list-style-type: none"> <li>• 2.2 mm wide</li> <li>• Gray</li> </ul> <p>Versions</p> <ul style="list-style-type: none"> <li>• For terminal size 2.5 ... 10 mm<sup>2</sup></li> <li>• For terminal size 16 mm<sup>2</sup></li> </ul>	<p>8WH9 000-1PA00 50 units</p> <p>8WH9 076-1PA00 50 units</p>
 <p>8WH9 002-8AC10</p>	<p><b>Reducing combs, for connecting terminals, for 8WH1</b></p> <p>Versions</p> <ul style="list-style-type: none"> <li>• From terminal size 6 mm<sup>2</sup> to 2.5 or 4 mm<sup>2</sup> <ul style="list-style-type: none"> <li>- From screw to screw</li> <li>- From screw to spring</li> </ul> </li> <li>• From terminal size 10 mm<sup>2</sup> to 2.5 or 4 mm<sup>2</sup> <ul style="list-style-type: none"> <li>- From screw to screw</li> <li>- From screw to spring</li> </ul> </li> <li>• From terminal size 16 mm<sup>2</sup> to 2.5 or 4 mm<sup>2</sup> <ul style="list-style-type: none"> <li>- From screw to screw</li> <li>- From screw to spring</li> </ul> </li> <li>• From terminal size 35 mm<sup>2</sup> to 2.5 or 4 mm<sup>2</sup> <ul style="list-style-type: none"> <li>- From screw to screw</li> <li>- From screw to spring</li> </ul> </li> </ul>	<p>8WH9 002-8AC10 10 units</p> <p>8WH9 002-8BC10 10 units</p> <p>8WH9 002-8CC10 10 units</p> <p>8WH9 002-8DC10 10 units</p> <p>8WH9 002-8EC10 10 units</p> <p>8WH9 002-8FC10 10 units</p> <p>8WH9 002-8GC10 10 units</p> <p>8WH9 002-8HC10 10 units</p>
<p><b>Compartment partitions, for through-type terminals, for terminal size 2.5 ... 10 mm<sup>2</sup>, for 8WH1</b></p> <ul style="list-style-type: none"> <li>• For visual and electrical separation of terminal groups</li> <li>• 2 mm thick</li> </ul>	<p>8WH9 070-6BA00</p>	<p>8WH9 070-6BA00 50 units</p>
 <p>8WH9 066-5BA06</p>	<p><b>Warning covers, for 8WH1</b></p> <ul style="list-style-type: none"> <li>• Lightning symbol</li> <li>• Yellow</li> </ul> <p>Versions</p> <ul style="list-style-type: none"> <li>• For terminal size 2.5 mm<sup>2</sup>, width 5.2 mm</li> <li>• For terminal size 4 mm<sup>2</sup>, width 6.2 mm</li> <li>• For terminal size 6 mm<sup>2</sup>, width 8.2 mm</li> <li>• For terminal size 10 mm<sup>2</sup>, width 10.2 mm</li> <li>• For terminal size 16 mm<sup>2</sup>, width 12.2 mm</li> <li>• For terminal size 35 mm<sup>2</sup>, width 16 mm</li> </ul>	<p>8WH9 060-5BA06 50 units</p> <p>8WH9 063-5BA06 50 units</p> <p>8WH9 064-5BA06 50 units</p> <p>8WH9 065-5BA06 50 units</p> <p>8WH9 066-5BA06 50 units</p> <p>8WH9 067-5BA06 50 units</p>

\* You can order this quantity or a multiple thereof.

# 8WH1 Screw Terminals

## 8WH fuse terminals

### Overview

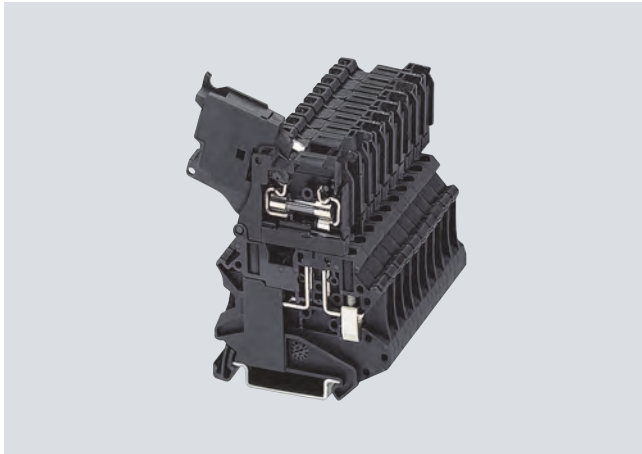

The 8WH fuse terminals adopt the function of the fuse holders for  $5 \times 20$  mm and  $6.3 \times 32$  mm G fuse links and all potential distribution tasks with the double bridge shaft.

The individual clamping points can be inscribed at the front using labels.







7

### Technical specifications

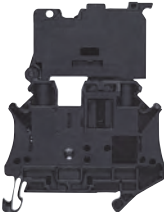
	8WH1 000-1GG08	8WH1 000-1KG38	8WH1 000-1MG88	8WH1 000-1HH08	8WH1 000-1PH38
Dimensions					
• Width/length/cover width in mm	6.2 / 57.8 / --			8.2 / 57.8 / --	
• Height (NS 35/7.5 / NS 35/15) in mm	73 / 80.5				
Technical specifications acc. to IEC/DIN VDE					
• Max. load current in A <sup>1)</sup> / cross-section in mm <sup>2</sup>	6.3 / 6			10 / 10	
• Rated impulse withstand voltage in kV / pollution degree	6 kV / 3		4 kV / 3	8 kV / 3	
• Rated insulation voltage (working voltage) $U_i$ in V acc. to IEC 60497-7-1	500			630	
• Overvoltage category / molded plastic group	III / I				
Connection capacities					
• Flexible with end sleeve, with plastic sleeve in mm <sup>2</sup>	0.25 ... 4			0.25 ... 6	
• Flexible with end sleeve, without plastic sleeve in mm <sup>2</sup>	0.25 ... 4			0.25 ... 6	
• Flexible with two-wire connection end sleeve, with plastic sleeve in mm <sup>2</sup>	0.5 ... 2.5			0.5 ... 4	
• Rigid in mm <sup>2</sup>	0.14 ... 6			0.2 ... 10	
Stripped length in mm	9			10	
Tightening torque in Nm	0.6 ... 0.8			1.5 ... 1.8	
Molded plastic type	PA				
• Flammability class acc. to UL 94	V0				
Approval data (UL/cUL and CSA)					
• Rated voltage / rated current / conductor sizes					
- UL/cUL: in V/A / AWG	600 / 6.3 / 26-10			600 / 16 / 24-8	
- CSA: in V/A / AWG	600 / 6.3 / 26-10			-- / -- / --	

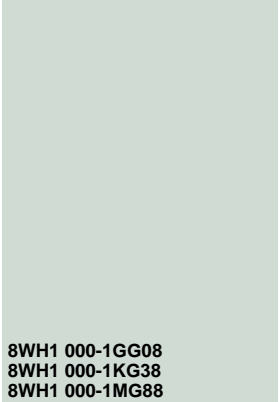
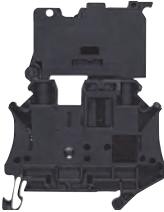
<sup>1)</sup> Please observe the maximum power loss.

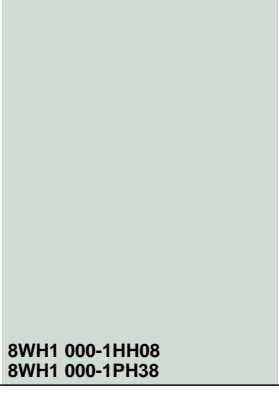
### Selection and ordering data

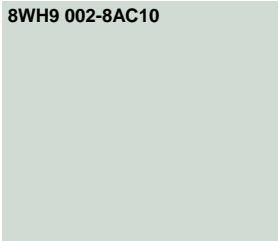
Version	Order No.	MOQ*
<b>Terminal size 4 mm<sup>2</sup></b>		
 <p>8WH1 000-1GG08</p> <p><b>Fuse terminals, terminal size 4 mm<sup>2</sup>, for 5 x 20 mm G fuse links</b></p> <ul style="list-style-type: none"> <li>•  US</li> <li>• Terminal width 6.2 mm</li> <li>• <math>I_{max} = 6.3</math> A</li> <li>• <math>U_{max} = 500</math> V</li> <li>• AWG 26-10</li> <li>• Connection capacity, one conductor <ul style="list-style-type: none"> <li>- Rigid 0.14 ... 6 mm<sup>2</sup></li> <li>- Flexible 0.14 ... 6 mm<sup>2</sup></li> </ul> </li> <li>• Connection capacity, two conductors <ul style="list-style-type: none"> <li>- Rigid 0.14 ... 1.5 mm<sup>2</sup></li> <li>- Flexible 0.14 ... 1.5 mm<sup>2</sup></li> </ul> </li> <li>• Enclosed at both ends</li> <li>• Black</li> </ul> <p><b>Versions</b></p> <ul style="list-style-type: none"> <li>• Without LED</li> <li>• With LED 10 ... 30 V AC/DC</li> <li>• With LED 110 ... 250 V AC/DC</li> </ul>	 <p><b>8WH1 000-1GG08</b></p> <p><b>8WH1 000-1KG38</b></p> <p><b>8WH1 000-1MG88</b></p>	<p>50 units</p> <p>50 units</p> <p>50 units</p>
<b>Terminal size 6 mm<sup>2</sup></b>		
 <p>8WH1 000-1HH08</p> <p><b>Fuse terminals, terminal size 6 mm<sup>2</sup>, for G fuse links 6.3 x 32 mm (inch fuses)</b></p> <ul style="list-style-type: none"> <li>•  US</li> <li>• Terminal width 8.2 mm</li> <li>• <math>I_{max} = 10</math> A</li> <li>• <math>U_{max} = 630</math> V</li> <li>• AWG 24-8</li> <li>• Connection capacity, one conductor <ul style="list-style-type: none"> <li>- Rigid 0.2 ... 10 mm<sup>2</sup></li> <li>- Flexible 0.2 ... 10 mm<sup>2</sup></li> </ul> </li> <li>• Connection capacity, two conductors <ul style="list-style-type: none"> <li>- Rigid 0.2 ... 2.5 mm<sup>2</sup></li> <li>- Flexible 0.2 ... 2.5 mm<sup>2</sup></li> </ul> </li> <li>• Enclosed at both ends</li> <li>• Black</li> </ul> <p><b>Versions</b></p> <ul style="list-style-type: none"> <li>• Without LED</li> <li>• With LED 12 ... 30 V AC/DC</li> </ul>	 <p><b>8WH1 000-1HH08</b></p> <p><b>8WH1 000-1PH38</b></p>	<p>50 units</p> <p>50 units</p>
<b>Accessories</b>		
 <p>8WH9 002-8AC10</p> <p><b>Reducing combs, for connecting terminals, from terminal size 6 mm<sup>2</sup> to 2.5 or 4 mm<sup>2</sup>, from screw to screw</b></p>	 <p><b>8WH9 002-8AC10</b></p>	<p>10 units</p>

Note:

For general accessories for 8WH terminal blocks, [see chapter 8](#).

# 8WH1 Screw Terminals

## 8WH isolating blade terminals

### Overview



Key features of the 8WH isolating blade terminals are their slim design and high current carrying capacity of 20 A. They can be bridged with standard terminal jumpers over the double bridge shaft.



The individual clamping points can be inscribed at the front using labels.

7

### Technical specifications

8WH1 000-6CG00	
Dimensions	
• Width/length/cover width in mm	6.2 / 57.8 / --
• Height (NS 35/7.5 / NS 35/15) in mm	49.1 / 56.6
Technical specifications acc. to IEC/DIN VDE	
• Max. load current in A / cross-section in mm <sup>2</sup>	20 / 6
• Rated impulse withstand voltage in kV / pollution degree	6 kV / 3
• Rated insulation voltage (working voltage) $U_i$ in V acc. to IEC 60497-7-1	500
• Overvoltage category / molded plastic group	III / I
Connection capacities	
• Flexible with end sleeve, with plastic sleeve in mm <sup>2</sup>	0.25 ... 4
• Flexible with end sleeve, without plastic sleeve in mm <sup>2</sup>	0.25 ... 4
• Flexible with two-wire connection end sleeve, with plastic sleeve in mm <sup>2</sup>	0.5 ... 2.5
• Rigid in mm <sup>2</sup>	0.14 ... 6
Stripped length in mm	9
Tightening torque in Nm	0.6 ... 0.8
Molded plastic type	PA
• Flammability class acc. to UL 94	V0
Approval data (UL/cUL and CSA)	
• Rated voltage / rated current / conductor sizes	
- UL/cUL: in V/A / AWG	600 / 16 / 26-10
- CSA: in V/A / AWG	600 / 16 / 26-10

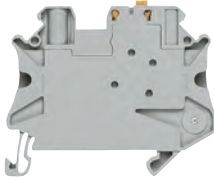
### Selection and ordering data

Version	Order No.	MOQ*
 <p><b>Terminal size 4 mm<sup>2</sup></b></p> <p><b>Isolating blade terminals, terminal size 4 mm<sup>2</sup></b></p> <ul style="list-style-type: none"> <li>•  US</li> <li>• Terminal width 6.2 mm</li> <li>• <math>I_{max} = 20</math> A</li> <li>• <math>U_{max} = 500</math> V</li> <li>• AWG 26-12</li> <li>• Connection capacity, one conductor <ul style="list-style-type: none"> <li>- Rigid 0.14 ... 4 mm<sup>2</sup></li> <li>- Flexible 0.14 ... 4 mm<sup>2</sup></li> </ul> </li> <li>• Connection capacity, two conductors <ul style="list-style-type: none"> <li>- Rigid 0.14 ... 1.5 mm<sup>2</sup></li> <li>- Flexible 0.14 ... 1.5 mm<sup>2</sup></li> </ul> </li> <li>• Enclosed at both ends</li> <li>• Gray</li> </ul> <p>8WH1 000-6CG00</p>	<b>8WH1 000-6CG00</b>	50 units
<p><b>Accessories</b></p> <p><b>Warning covers, for terminal size 4 mm<sup>2</sup></b></p> <ul style="list-style-type: none"> <li>• Lightning symbol</li> <li>• Width 6.2 mm</li> <li>• Yellow</li> </ul>	<b>8WH9 063-5BA06</b>	50 units

Note:

For general accessories for 8WH terminal blocks, [see chapter 8](#).

### Overview

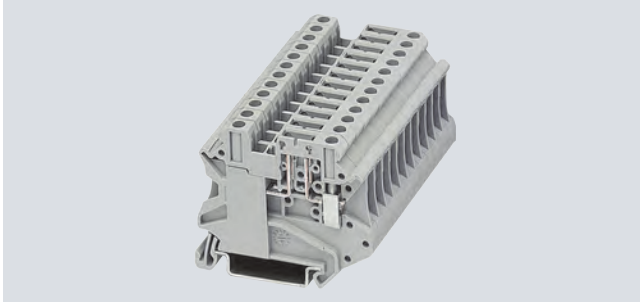





8WH isolating terminals serve for mounting various function plugs.

The individual clamping points can be inscribed at the front using labels.

### Technical specifications

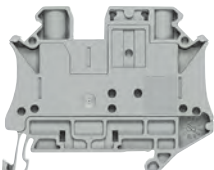
	8WH1 000-6AG00	8WH1 000-6AH00
Dimensions		
• Width/length/cover width in mm	6.2 / 57.8 / --	73 / 80.5
• Height (NS 35/7.5 / NS 35/15) in mm	49.1 / 56.6	
Technical specifications acc. to IEC/DIN VDE		
• Max. load current in A / cross-section in mm <sup>2</sup>	20 / 6	20 / 10
• Rated impulse withstand voltage in kV / pollution degree	6 kV / 3	
• Rated insulation voltage (working voltage) $U_i$ in V acc. to IEC 60497-7-1	500	
• Overvoltage category / molded plastic group	III / I	
Connection capacities		
• Flexible with end sleeve, with plastic sleeve in mm <sup>2</sup>	0.25 ... 4	0.26 ... 6
• Flexible with end sleeve, without plastic sleeve in mm <sup>2</sup>	0.25 ... 4	0.26 ... 6
• Flexible with two-wire connection end sleeve, with plastic sleeve in mm <sup>2</sup>	0.5 ... 2.5	0.5 ... 4
• Rigid in mm <sup>2</sup>	0.14 ... 6	0.2 ... 10
Stripped length in mm	9	10
Tightening torque in Nm	0.6 ... 0.8	1.5 ... 1.8
Molded plastic type	PA	
• Flammability class acc. to UL 94	V0	
Approval data (UL/cUL and CSA)		
• Rated voltage / rated current / conductor sizes		
- UL/cUL: in V/A / AWG	600 / 16 / 26-10	-- / -- / --
- CSA: in V/A / AWG	600 / 16 / 26-10	-- / -- / --

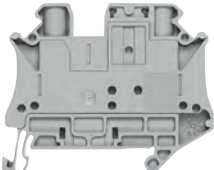
### Selection and ordering data

Version	Order No.	MOQ*
<b>Terminal size 4 mm<sup>2</sup></b>  <b>8WH1 000-6AG00</b> <b>Isolating terminals, terminal size 4 mm<sup>2</sup></b> <ul style="list-style-type: none"> <li>•   US</li> <li>• Terminal width 6.2 mm</li> <li>• <math>I_{max} = 20</math> A</li> <li>• <math>U_{max} = 400</math> V</li> <li>• AWG 26-10</li> <li>• Connection capacity, one conductor                             <ul style="list-style-type: none"> <li>- Rigid 0.14 ... 6 mm<sup>2</sup></li> <li>- Flexible 0.14 ... 6 mm<sup>2</sup></li> </ul> </li> <li>• Connection capacity, two conductors                             <ul style="list-style-type: none"> <li>- Rigid 0.14 ... 1.5 mm<sup>2</sup></li> <li>- Flexible 0.14 ... 1.5 mm<sup>2</sup></li> </ul> </li> <li>• Enclosed at both ends</li> <li>• Gray</li> </ul>	<b>8WH1 000-6AG00</b>	50 units
<b>Terminal size 6 mm<sup>2</sup></b>  <b>8WH1 000-6AH00</b> <b>Isolating terminals, terminal size 6 mm<sup>2</sup></b> <ul style="list-style-type: none"> <li>•   US</li> <li>• Terminal width 8.2 mm</li> <li>• <math>I_{max} = 20</math> A</li> <li>• <math>U_{max} = 500</math> V</li> <li>• AWG 24-8</li> <li>• Connection capacity, one conductor                             <ul style="list-style-type: none"> <li>- Rigid 0.2 ... 10 mm<sup>2</sup></li> <li>- Flexible 0.2 ... 10 mm<sup>2</sup></li> </ul> </li> <li>• Connection capacity, two conductors                             <ul style="list-style-type: none"> <li>- Rigid 0.2 ... 2.5 mm<sup>2</sup></li> <li>- Flexible 0.2 ... 2.5 mm<sup>2</sup></li> </ul> </li> <li>• Enclosed at both ends</li> <li>• Gray</li> </ul>	<b>8WH1 000-6AH00</b>	50 units

\* You can order this quantity or a multiple thereof.

# 8WH1 Screw Terminals

## 8WH two-tier terminals

### Overview

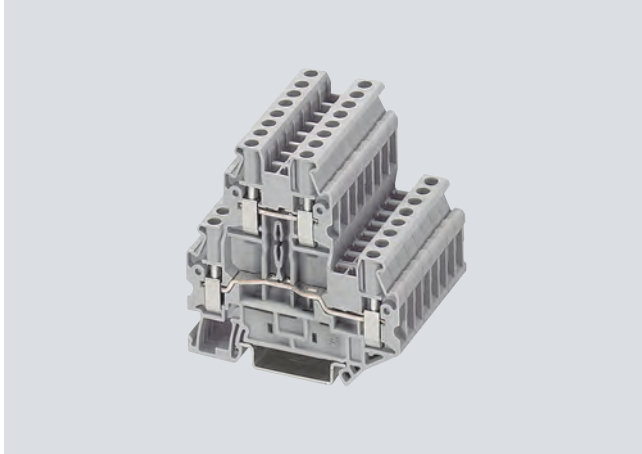

The compact 8WH1 two-tier terminal is available in the nominal cross-sections 2.5 and 4 mm<sup>2</sup>. The voltage levels routed in a 5.2 mm or 6.2 mm grid through two tiers reduce the space required in the control cabinet by a further 50%. Two integral bridge shafts per tier and two facilities for large inscriptions of all clamping points are provided.

With 8WH1 025 two-tier terminals the upper and lower level are connected.





The tier offset on the 8WH two-tier terminals allows for excellent access to the lower level, even when fully wired. Spacer plates can be used to compensate for the tier offset if other terminals are mounted side by side.

The clamping points of the 8WH1 two-tier terminals can be inscribed at the front using the labels.

### Technical specifications

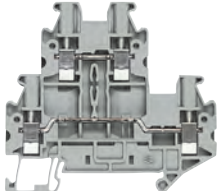
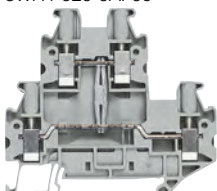
	<b>8WH1 020-0AF00</b> <b>8WH1 020-0AF01</b>	<b>8WH1 020-0AG00</b> <b>8WH1 020-0AG01</b>	<b>8WH1 020-0CF07</b>	<b>8WH1 020-0CG07</b>
Dimensions				
• Width/length/cover width in mm	5.2 / 69.9 / 2.2	6.2 / 69.9 / 2.2	5.2 / 69.9 / 2.2	6.2 / 69.9 / 2.2
• Height (NS 35/7.5 / NS 35/15) in mm	65 / 72.5			
Technical specifications acc. to IEC/DIN VDE				
• Max. load current in A / cross-section in mm <sup>2</sup>	28 / 4	36 / 6	-- / 4	-- / 6
• Rated impulse withstand voltage in kV / pollution degree	6 kV / 3	8 kV / 3		
• Rated insulation voltage (working voltage) $U_i$ in V	500	800	--	
acc. to IEC 60497-7-1				
• Overvoltage category / molded plastic group	III / I			
Connection capacities				
• Flexible with end sleeve, with plastic sleeve in mm <sup>2</sup>	0.25 ... 2.5	0.25 ... 4	0.25 ... 2.5	0.25 ... 4
• Flexible with end sleeve, without plastic sleeve in mm <sup>2</sup>	0.25 ... 2.5	0.25 ... 4	0.25 ... 2.5	0.25 ... 4
• Flexible with two-wire connection end sleeve, with plastic sleeve in mm <sup>2</sup>	0.5 ... 1.5	0.5 ... 2.5	0.5 ... 1.5	0.5 ... 2.5
• Rigid in mm <sup>2</sup>	0.14 ... 4	0.14 ... 6	0.14 ... 4	0.14 ... 6
Stripped length in mm	9			
Tightening torque in Nm	0.5 ... 0.6	0.6 ... 0.8	0.5 ... 0.6	0.6 ... 0.8
Molded plastic type	PA			
• Flammability class acc. to UL 94	V0			
Approval data (UL/cUL and CSA)				
• Rated voltage / rated current / conductor sizes				
- UL/cUL: in V/A / AWG	600 / 20 / 26-12	600 / 30 / 26-12	-- / -- / 26-12	-- / -- / 26-10
- CSA: in V/A / AWG	-- / -- / --			
	<b>8WH1 025-0AF00</b>	<b>8WH1 025-0AG00</b>		
Dimensions				
• Width/length/cover width in mm	6.2 / 69.9 / 2.2			
• Height (NS 35/7.5 / NS 35/15) in mm	65 / 72.5			
Technical specifications acc. to IEC/DIN VDE				
• Max. load current in A / cross-section in mm <sup>2</sup>	28 / 4	36 / 6		
• Rated impulse withstand voltage in kV / pollution degree	6 kV / 3	8 kV / 3		
• Rated insulation voltage (working voltage) $U_i$ in V	500			
acc. to IEC 60497-7-1				
• Overvoltage category / molded plastic group	III / I			
Connection capacities				
• Flexible with end sleeve, with plastic sleeve in mm <sup>2</sup>	0.25 ... 2.5	0.25 ... 4		
• Flexible with end sleeve, without plastic sleeve in mm <sup>2</sup>	0.25 ... 2.5	0.25 ... 4		
• Flexible with two-wire connection end sleeve, with plastic sleeve in mm <sup>2</sup>	0.5 ... 1.5	0.5 ... 2.5		
• Rigid in mm <sup>2</sup>	0.14 ... 4	0.14 ... 6		
Stripped length in mm	9			
Tightening torque in Nm	0.5 ... 0.6	0.6 ... 0.8		
Molded plastic type	PA			
• Flammability class acc. to UL 94	V0			
Approval data (UL/cUL and CSA)				
• Rated voltage / rated current / conductor sizes				
- UL/cUL: in V/A / AWG	600 / 20 / 26-12	600 / 30 / 26-10		
- CSA: in V/A / AWG	-- / -- / --			

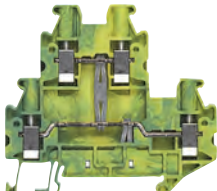
### Selection and ordering data







Version	Order No.	MOQ*
<b>Terminal size 2.5 mm<sup>2</sup></b>		
 <p>8WH1 020-0AF00</p>  <p>8WH1 025-0AF00</p>	<p><b>Two-tier terminals, terminal size 2.5 mm<sup>2</sup></b></p> <ul style="list-style-type: none"> <li>•  US</li> <li>• Terminal width 5.2 mm</li> <li>• <math>I_{max} = 28</math> A</li> <li>• <math>U_{max} = 500</math> V</li> <li>• AWG 26-12</li> <li>• Connection capacity, one conductor                     <ul style="list-style-type: none"> <li>- Rigid 0.14 ... 4 mm<sup>2</sup></li> <li>- Flexible 0.14 ... 4 mm<sup>2</sup></li> </ul> </li> <li>• Connection capacity, two conductors                     <ul style="list-style-type: none"> <li>- Rigid 0.14 ... 1.5 mm<sup>2</sup></li> <li>- Flexible 0.14 ... 1.5 mm<sup>2</sup></li> </ul> </li> </ul> <p><b>Versions</b></p> <ul style="list-style-type: none"> <li>• Gray                     <ul style="list-style-type: none"> <li>- Without equipotential bonding</li> <li>- With equipotential bonding</li> </ul> </li> <li>• Blue                     <ul style="list-style-type: none"> <li>- Without equipotential bonding</li> </ul> </li> </ul>	<p><b>8WH1 020-0AF00</b> 50 units</p> <p><b>8WH1 025-0AF00</b> 50 units</p> <p><b>8WH1 020-0AF01</b> 50 units</p>
 <p>8WH1 020-0CF07</p>	<p><b>PE two-tier terminals, terminal size 2.5 mm<sup>2</sup></b></p> <ul style="list-style-type: none"> <li>•  US</li> <li>• Terminal width 5.2 mm</li> <li>• AWG 26-12</li> <li>• Connection capacity, one conductor                     <ul style="list-style-type: none"> <li>- Rigid 0.14 ... 4 mm<sup>2</sup></li> <li>- Flexible 0.14 ... 4 mm<sup>2</sup></li> </ul> </li> <li>• Connection capacity, two conductors                     <ul style="list-style-type: none"> <li>- Rigid 0.14 ... 1.5 mm<sup>2</sup></li> <li>- Flexible 0.14 ... 1.5 mm<sup>2</sup></li> </ul> </li> <li>• Green/yellow</li> </ul>	<p><b>8WH1 020-0CF07</b> 50 units</p>

\* You can order this quantity or a multiple thereof.

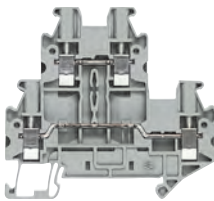
# 8WH1 Screw Terminals

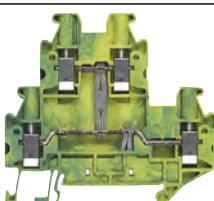
## 8WH two-tier terminals

7

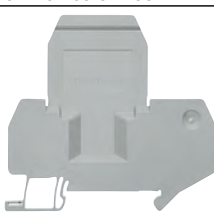
Version	Order No.	MOQ*
<b>Terminal size 4 mm<sup>2</sup></b>		
 <p>8WH1 020-0AG00</p>	<p><b>Two-tier terminals, terminal size 4 mm<sup>2</sup></b></p> <ul style="list-style-type: none"> <li>•  US</li> <li>• Terminal width 6.2 mm</li> <li>• <math>I_{max} = 36\text{ A}</math></li> <li>• <math>U_{max} = 800\text{ V}</math></li> <li>• AWG 26-10</li> <li>• Connection capacity, one conductor               <ul style="list-style-type: none"> <li>- Rigid 0.14 ... 6 mm<sup>2</sup></li> <li>- Flexible 0.14 ... 6 mm<sup>2</sup></li> </ul> </li> <li>• Connection capacity, two conductors               <ul style="list-style-type: none"> <li>- Rigid 0.14 ... 1.5 mm<sup>2</sup></li> <li>- Flexible 0.14 ... 1.5 mm<sup>2</sup></li> </ul> </li> </ul> <p><b>Versions</b></p> <ul style="list-style-type: none"> <li>• Gray               <ul style="list-style-type: none"> <li>- Without equipotential bonding</li> <li>- With equipotential bonding</li> </ul> </li> <li>• Blue               <ul style="list-style-type: none"> <li>- Without equipotential bonding</li> </ul> </li> </ul>	<p><b>8WH1 020-0AG00</b> <b>8WH1 025-0AG00</b></p> <p>50 units 50 units</p> <p><b>8WH1 020-0AG01</b></p> <p>50 units</p>
 <p>8WH1 020-0CG07</p>	<p><b>PE two-tier terminals, terminal size 4 mm<sup>2</sup></b></p> <ul style="list-style-type: none"> <li>•  US</li> <li>• Terminal width 6.2 mm</li> <li>• AWG 26-10</li> <li>• Connection capacity, one conductor               <ul style="list-style-type: none"> <li>- Rigid 0.14 ... 6 mm<sup>2</sup></li> <li>- Flexible 0.14 ... 6 mm<sup>2</sup></li> </ul> </li> <li>• Connection capacity, two conductors               <ul style="list-style-type: none"> <li>- Rigid 0.14 ... 1.5 mm<sup>2</sup></li> <li>- Flexible 0.14 ... 1.5 mm<sup>2</sup></li> </ul> </li> <li>• Green/yellow</li> </ul>	<p><b>8WH1 020-0CG07</b></p> <p>50 units</p>
<b>Accessories</b>		
 <p>8WH9 000-1QA00</p>	<p><b>Covers, for two-tier terminals, for terminal size 2.5 ... 4 mm<sup>2</sup></b></p> <ul style="list-style-type: none"> <li>• Width 2.2 mm</li> <li>• Gray</li> </ul>	<p><b>8WH9 000-1QA00</b></p> <p>50 units</p>
 <p>8WH9 160-0AA00</p>	<p><b>Spacer plates, for two-tier terminals, for terminal size 2.5 ... 4 mm<sup>2</sup></b></p> <ul style="list-style-type: none"> <li>• Compensates for tier offset if other terminals are mounted side by side</li> <li>• 2.5 mm thick</li> <li>• Gray</li> </ul>	<p><b>8WH9 160-0AA00</b></p> <p>50 units</p>
 <p>8WH9 070-6FA00</p>	<p><b>Compartment partitions, for two-tier terminals, for terminal size 2.5 ... 4 mm<sup>2</sup></b></p> <ul style="list-style-type: none"> <li>• For visual and electrical separation of terminal groups</li> <li>• 2 mm thick</li> <li>• Gray</li> </ul>	<p><b>8WH9 070-6FA00</b></p> <p>50 units</p>

Note:

For general accessories for 8WH terminal blocks, [see chapter 8](#).

### Overview

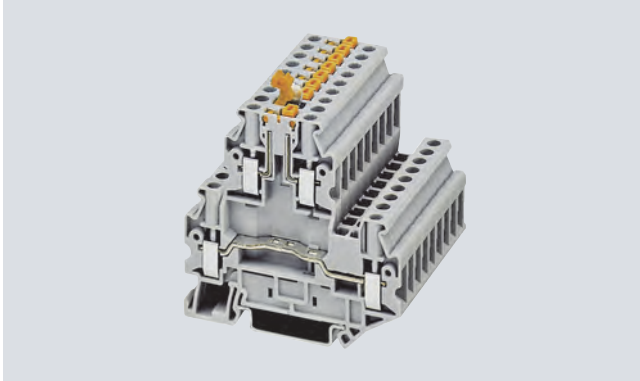

Two-tier terminals with isolating function/isolating blade are also available with the same contour as 8WH1 two-tier terminals.

An increasing number of contact points need to be wired in the same space in the signal wiring. The two voltage levels routed through two separate tiers require 50% less space than equivalent single-tier terminals.

To implement a wide range of wiring tasks, particularly in measuring and control technology, an isolating blade or an isolating plug, a component plug or a fused plug for 5 x 20 mm glass tube fuses can be used in the standardized separation zone in the upper tier.

The looping of measuring devices is possible over the terminal screws with integrated test socket so that voltage and current measurements can be performed on both tiers without interruption. The tier offset makes access to the lower tier much easier.

The clamping points of two-tier terminals can be inscribed at the front using the labels.

### Technical specifications

	8WH1 020-6AC00	8WH1 020-6AG00
Dimensions		
• Width/length/cover width in mm	6.2 / 69.9 / 2.2	
• Height (NS 35/7.5 / NS 35/15) in mm	65 / 72.5	
Technical specifications acc. to IEC/DIN VDE		
• Max. load current in A / cross-section in mm <sup>2</sup>	38 <sup>1)</sup> / 6	
• Rated impulse withstand voltage in kV / pollution degree	6 kV / 3	
• Rated insulation voltage (working voltage) $U_i$ in V acc. to IEC 60497-7-1	500	
• Overvoltage category / molded plastic group	III / I	
Connection capacities		
• Flexible with end sleeve, with plastic sleeve in mm <sup>2</sup>	0.25 ... 4	
• Flexible with end sleeve, without plastic sleeve in mm <sup>2</sup>	0.25 ... 4	
• Flexible with two-wire connection end sleeve, with plastic sleeve in mm <sup>2</sup>	0.5 ... 2.5	
• Rigid in mm <sup>2</sup>	0.14 ... 6	
Stripped length in mm	9	
Tightening torque in Nm	0.6 ... 0.8	
Molded plastic type	PA	
• Flammability class acc. to UL 94	V0	
Approval data (UL/cUL and CSA)		
• Rated voltage / rated current / conductor sizes		
- UL/cUL: in V/A / AWG	600 / 5 / 26-10	
- CSA: in V/A / AWG	-- / -- / --	

<sup>1)</sup> Bottom level

### Selection and ordering data

Version	Order No.	MOQ*

#### Terminal size 4 mm<sup>2</sup>

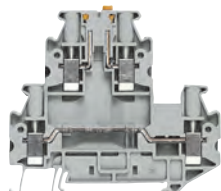

8WH1 020-6AC00

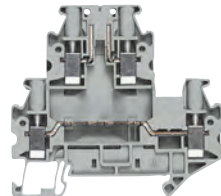

8WH1 020-6AG00

#### Two-tier terminal, with isolating function/isolating blade, terminal size 4 mm<sup>2</sup>

- 
- Terminal width 6.2 mm
- $I_{max} = 38$  A
- $U_{max} = 500$  V
- AWG 26-10
- Connection capacity, one conductor
  - Rigid 0.14 ... 6 mm<sup>2</sup>
  - Flexible 0.14 ... 6 mm<sup>2</sup>
- Connection capacity, two conductors
  - Rigid 0.14 ... 1.5 mm<sup>2</sup>
  - Flexible 0.14 ... 1.5 mm<sup>2</sup>

#### Versions

- Isolating links in the upper tier
- Isolating terminal in the upper tier



**8WH1 020-6AC00**  
**8WH1 020-6AG00**

50 units  
50 units

\* You can order this quantity or a multiple thereof.

# 8WH1 Screw Terminals

## 8WH two-tier terminals with isolating function/isolating blade

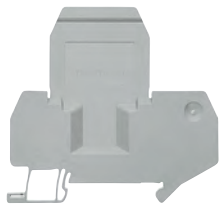
Version	Order No.	MOQ*
<b>Accessories</b>		
 <p>8WH9 000-1QA00</p>	<p><b>Covers, for two-tier terminals, for terminal size 2.5 ... 4 mm<sup>2</sup></b></p> <ul style="list-style-type: none"> <li>• Width 2.2 mm</li> <li>• Gray</li> </ul>	<p><b>8WH9 000-1QA00</b> 50 units</p>
 <p>8WH9 160-0AA00</p>	<p><b>Spacer plates, for two-tier terminals, for terminal size 2.5 ... 4 mm<sup>2</sup></b></p> <ul style="list-style-type: none"> <li>• Compensates for tier offset if other terminals are mounted side by side</li> <li>• 2.5 mm thick</li> <li>• Gray</li> </ul>	<p><b>8WH9 160-0AA00</b> 50 units</p>
 <p>8WH9 070-6FA00</p>	<p><b>Compartment partitions, for two-tier terminals, for terminal size 2.5 ... 4 mm<sup>2</sup></b></p> <ul style="list-style-type: none"> <li>• For visual and electrical separation of terminal groups</li> <li>• 2 mm thick</li> <li>• Gray</li> </ul>	<p><b>8WH9 070-6FA00</b> 50 units</p>

Note:

For general accessories for 8WH terminal blocks, [see chapter 8](#).

### Overview

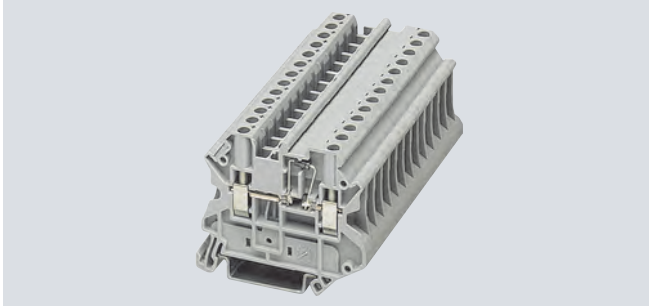

8WH diode terminals can be used to implement many different wiring tasks. The 1N 4007 diode is soldered in from left to right or vice versa as required.

The double bridge shaft allows for combination with all standard and function terminals.

The 8WH diode terminals have the same contour as the 8WH isolating, isolating blade and fuse terminals. This has the advantage of enabling consistent inscriptions on all clamping points. Secure electrical and mechanical contact with the support rail is assured by simply snapping the terminals onto the rail.



The clamping points of diode terminals can be inscribed at the front using the labels.

### Technical specifications

	8WH1 000-6KG00	8WH1 000-6LG00
Dimensions		
• Width/length/cover width in mm	6.2 / 57.8 / 2.2	
• Height (NS 35/7.5 / NS 35/15) in mm	47.5 / 55	
Technical specifications acc. to IEC/DIN VDE		
• Max. load current in A <sup>1)</sup> / cross-section in mm <sup>2</sup>	-- / 6	
• Rated impulse withstand voltage in kV / pollution degree	8 kV / 3	
• Rated insulation voltage (working voltage) $U_i$ in V acc. to IEC 60497-7-1	800	
• Overvoltage category / molded plastic group	III / I	
Connection capacities		
• Flexible with end sleeve, with plastic sleeve in mm <sup>2</sup>	0.25 ... 4	
• Flexible with end sleeve, without plastic sleeve in mm <sup>2</sup>	0.25 ... 4	
• Flexible with two-wire connection end sleeve, with plastic sleeve in mm <sup>2</sup>	0.5 ... 2.5	
• Rigid in mm <sup>2</sup>	0.14 ... 6	
Stripped length in mm	9	
Tightening torque in Nm	0.6 ... 0.8	
Molded plastic type	PA	
• Flammability class acc. to UL 94	V0	
Approval data (UL/cUL and CSA)		
• Rated voltage / rated current / conductor sizes		
- UL/cUL: in V/A / AWG	600 / 1 / 26-10	600 / 1 / 26-10
- CSA: in V/A / AWG	600 / 1 / 26-10	600 / 1 / 26-10

<sup>1)</sup> Maximum current determined by diode. A 1N 4007 diode is integrated, blocking voltage: 1300 V, max. continuous current: 0.5 A

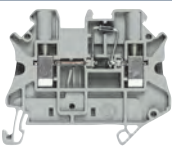
### Selection and ordering data

Version	Order No.	MOQ*
<b>Terminal size 4 mm<sup>2</sup></b>		
 <p>8WH1 000-6KG00</p> <p><b>Diode terminals, terminal size 4 mm<sup>2</sup>, gray, C<sub>UL</sub> US, ©</b></p> <ul style="list-style-type: none"> <li>Terminal width 6.2 mm</li> <li><math>I_{max} = 0.5 A</math>, <math>U_{max} = 800 V</math></li> <li>AWG 26-10</li> <li>Connection capacity, one conductor                     <ul style="list-style-type: none"> <li>- Rigid 0.14 ... 6 mm<sup>2</sup>, flexible 0.14 ... 6 mm<sup>2</sup></li> </ul> </li> <li>Connection capacity, two conductors                     <ul style="list-style-type: none"> <li>- Rigid 0.14 ... 1.5 mm<sup>2</sup>, flexible 0.14 ... 1.5 mm<sup>2</sup></li> </ul> </li> <li>With integrated diode: 1N 4007</li> </ul> <p>Versions</p> <ul style="list-style-type: none"> <li>Let-through from left to right</li> <li>Let-through from right to left</li> </ul>	<p><b>8WH1 000-6LG00</b></p> <p><b>8WH1 000-6KG00</b></p>	<p>50 units</p> <p>50 units</p>
<b>Accessories</b>		
 <p>8WH9 000-2PA00</p> <p><b>Covers, for diode terminals, for terminal size 2.5 ... 4 mm<sup>2</sup></b></p> <ul style="list-style-type: none"> <li>Width 2.2 mm</li> <li>Gray</li> </ul>	<b>8WH9 000-2PA00</b>	50 units
<p><b>Warning covers, for terminal size 4 mm<sup>2</sup></b></p> <ul style="list-style-type: none"> <li>Lightning symbol, yellow</li> </ul>	<b>8WH9 063-5BA06</b>	50 units

Note: For general accessories for 8WH terminal blocks, see chapter 8.

# 8WH1 Screw Terminals

## 8WH two-tier diode terminals

### Overview

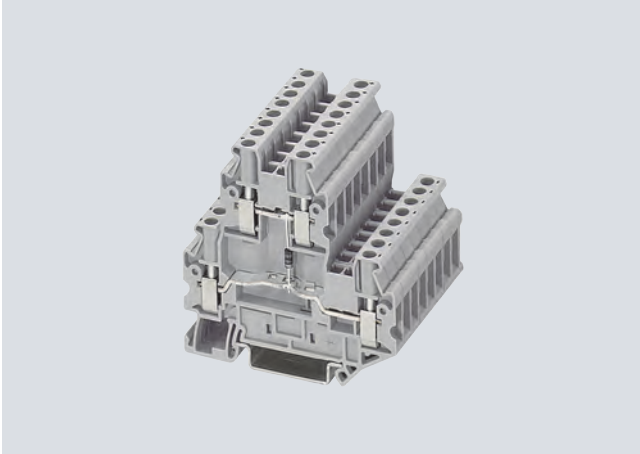

8WH two-tier diode terminals with a width of only 5.2 mm can be used to implement many different wiring tasks. This makes the following possible in the narrowest of spaces:

- Freewheel diode circuits
- Lamp test circuits
- Signaling and fault signaling circuits.

The clamping points of the 8WH1 two-tier diode terminals can be inscribed at the front using the labels.





7

### Technical specifications

	8WH1 020-5AF00	8WH1 020-5BF00	8WH1 020-5DF00	8WH1 020-5FF00	8WH1 020-5HF00
Dimensions					
• Width/length/cover width in mm	5.2 / 69.9 / 2.2				
• Height (NS 35/7.5 / NS 35/15) in mm	65 / 72.5				
Technical specifications acc. to IEC/DIN VDE					
• Max. load current in A <sup>1)</sup> / cross-section in mm <sup>2</sup>	28 / 4				
• Rated impulse withstand voltage in kV / pollution degree	6 kV / 3				
• Rated insulation voltage (working voltage) $U_i$ in V acc. to IEC 60497-7-1	500				
• Overvoltage category / molded plastic group	III / I				
Connection capacities					
• Flexible with end sleeve, with plastic sleeve in mm <sup>2</sup>	0.25 ... 2.5				
• Flexible with end sleeve, without plastic sleeve in mm <sup>2</sup>	0.25 ... 2.5				
• Flexible with two-wire connection end sleeve, with plastic sleeve in mm <sup>2</sup>	0.5 ... 1.5				
• Rigid in mm <sup>2</sup>	0.14 ... 4				
Stripped length in mm	9				
Tightening torque in Nm	0.5 ... 0.6				
Molded plastic type	PA				
• Flammability class acc. to UL 94	V0				
Approval data (UL/cUL and CSA)					
• Rated voltage / rated current / conductor sizes					
- UL/cUL: in V/A / AWG	-- / -- / --				
- CSA: in V/A / AWG	-- / -- / --				

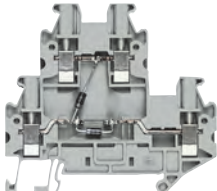
<sup>1)</sup> Maximum current determined by diode.  
 Integrated: diode 1N 4007, blocking voltage: 1300 V  
 max. continuous current: 0.5 A

### Selection and ordering data

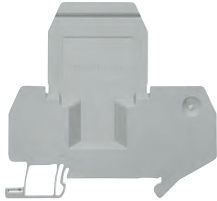
Version	Order No.	MOQ*
<b>Terminal size 2.5 mm<sup>2</sup></b>		
 <p>8WH1 020-5FF00</p> <p><b>Two-tier diode terminals, terminal size 2.5 mm<sup>2</sup></b></p> <ul style="list-style-type: none"> <li>•  US</li> <li>• Terminal width 6.2 mm</li> <li>• <math>I_{max} = 0.5</math> A</li> <li>• <math>U_{max} = 800</math> V</li> <li>• AWG 26-10</li> <li>• Connection capacity, one conductor <ul style="list-style-type: none"> <li>- Rigid 0.14 ... 4 mm<sup>2</sup></li> <li>- Flexible 0.14 ... 4 mm<sup>2</sup></li> </ul> </li> <li>• Connection capacity, two conductors <ul style="list-style-type: none"> <li>- Rigid 0.14 ... 1.5 mm<sup>2</sup></li> <li>- Flexible 0.14 ... 1.5 mm<sup>2</sup></li> </ul> </li> <li>• With integrated diode: 1N 4007</li> <li>• Gray</li> </ul> <p><b>Versions</b></p> <ul style="list-style-type: none"> <li>• With 1N 4007 diode integrated <ul style="list-style-type: none"> <li>- Let-through from top to bottom</li> <li>- Let-through from bottom to top</li> <li>- Let-through from bottom left to top right</li> </ul> </li> <li>• With two 1N 4007 diodes integrated <ul style="list-style-type: none"> <li>- Let-through from top to bottom left and from bottom right to bottom left</li> <li>- Let-through from top to bottom left and from top to bottom right</li> </ul> </li> </ul>	<p><b>8WH1 020-5AF00</b></p> <p><b>8WH1 020-5BF00</b></p> <p><b>8WH1 020-5DF00</b></p> <p><b>8WH1 020-5FF00</b></p> <p><b>8WH1 020-5HF00</b></p>	<p>50 units</p> <p>50 units</p> <p>50 units</p> <p>50 units</p> <p>50 units</p>
<b>Accessories</b>		
 <p>8WH9 000-1QA00</p> <p><b>Covers, for two-tier terminals, for terminal size 2.5 ... 4 mm<sup>2</sup></b></p> <ul style="list-style-type: none"> <li>• Width 2.2 mm</li> <li>• Gray</li> </ul>	<b>8WH9 000-1QA00</b>	50 units
 <p>8WH9 160-0AA00</p> <p><b>Spacer plates, for two-tier terminals, for terminal size 2.5 ... 4 mm<sup>2</sup></b></p> <ul style="list-style-type: none"> <li>• Compensates for tier offset if other terminals are mounted side by side</li> <li>• 2.5 mm thick</li> <li>• Gray</li> </ul>	<b>8WH9 160-0AA00</b>	50 units
 <p>8WH9 070-6FA00</p> <p><b>Compartment partitions, for two-tier terminals, for terminal size 2.5 ... 4 mm<sup>2</sup></b></p> <ul style="list-style-type: none"> <li>• For visual and electrical separation of terminal groups</li> <li>• 2 mm thick</li> <li>• Gray</li> </ul>	<b>8WH9 070-6FA00</b>	50 units

Note:

For general accessories for 8WH terminal blocks, [see chapter 8](#).

# 8WH1 Screw Terminals

## 8WH high-current terminals

### Overview

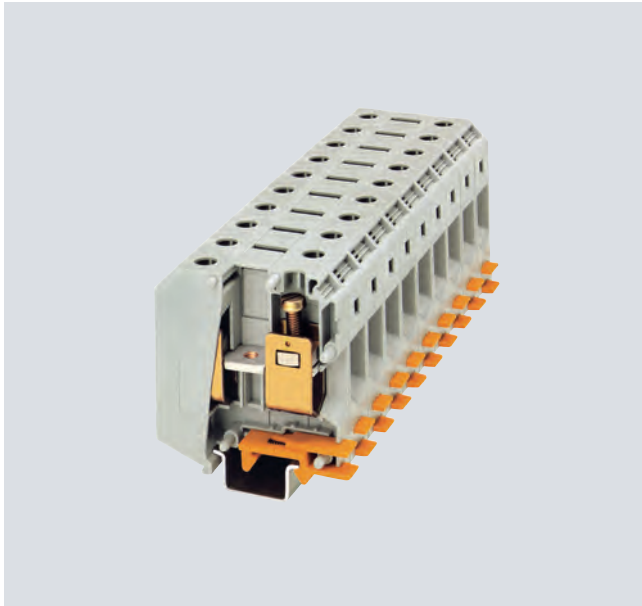

The high-current terminals cover cross-sectional areas from 16 to 240 mm<sup>2</sup>. A reliable cable connection is ensured through effective design measures, such as:

- Three-point centering of the conductor in the prismatic sleeve base
- Low contact resistance of the contact area through grooved surface
- Screw locking through spring-loaded elements
- Terminals enclosed at both ends.

The terminals have an enclosed insulating body made of polyamide 6.6.

The terminals are available in gray and blue.

8WH labels must be used at the front for inscription purposes.

For terminals with terminal sizes up to 95 mm<sup>2</sup>, green-yellow PE/ground conductor terminals are available.

Mounting on support rails acc. to IEC 60715.

7

### Benefits

- Larger connection up to 240 mm<sup>2</sup>
- The right terminal is always available - whatever the connection functions
- Simple inscription using 8WH standard
- Comprehensive range of accessories available
- Enclosed insulating body made of polyamide 6.6.

### Design

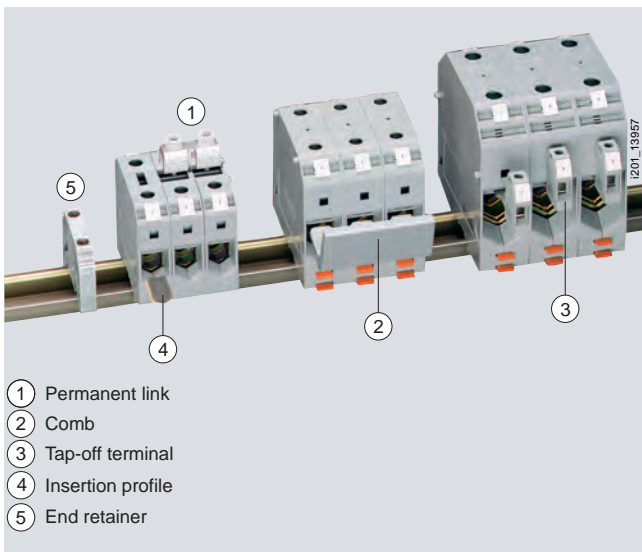

Using the 50 mm<sup>2</sup> terminals, permanent links can be mounted in 2 and 3-pole versions. Combs are required with 95 ... 240 mm<sup>2</sup> terminals.

Assembled terminal blocks







### Technical specifications

	8WH1 000-0AN00 8WH1 000-0AN01	8WH1 000-0CN07	8WH1 000-0AQ00 8WH1 000-0AQ01
Dimensions			
• Width/length in mm	20 / 70.5		25 / 83
• Height (TS 35/7.5 / TS 35/15 / TS 32) in mm	-- / 83.5 / 81.5		-- / 97.5 / 95.5
Technical specifications acc. to IEC/DIN VDE			
• Max. load current in A / cross-section in mm <sup>2</sup>	150 / 50		232 / 95
• Maximum cross-section with comb (rigid/flexible) in mm <sup>2</sup>	--		95 / 70
• Rated impulse withstand voltage in kV / pollution degree	8 / 3		
• Overvoltage category / molded plastic group	III / I		
Connection capacities			
• Flexible with end sleeve without/with plastic sleeve in mm <sup>2</sup>	25 ... 50 / 25 ... 50		35 ... 95 / 35 ... 95
Multi-conductor connection (two conductors of same cross-section)			
• Rigid/flexible in mm <sup>2</sup>	10 ... 16 / 10 ... 16		25 ... 35 / 25 ... 35
• Flexible with end sleeve, without plastic sleeve in mm <sup>2</sup>	10 ... 16		16 ... 35
Stripped length in mm	24		33
Plug gauge (IEC 60947-1)	B10		B12
Screw thread	M6	--	M8
Tightening torque in Nm	6 ... 8	--	15 ... 20
Clamping point: screw thread / tightening torque in Nm	--	M6 / 6 ... 8	--
Fixing: screw thread / tightening torque in Nm	--	M6 / 6 ... 8	--
Molded plastic type	PA		
• Flammability class acc. to UL 94	V0		
Approval data (UL/cUL and CSA)			
• Rated voltage / rated current / conductor sizes			
- UL/cUL: V/A/AWG	600 / 150 / 6 - 0	6 - 1 / 0	600 / 230 / 2 - 000
- CSA: V/A/AWG	600 / 125 / 6 - 0	--	600 / 230 / 1 - 000
Support rails/protective conductor busbars	--	See section "Support rails" on page 1/3	--
	8WH1 000-0CQ07	8WH1 000-0AS00 8WH1 000-0AS01	8WH1 000-0AU00 8WH1 000-0AU01
Dimensions			
• Width/length in mm	25 / 83	31 / 100	36 / 100
• Height (TS 35/7.5 / TS 35/15 / TS 32) in mm	-- / 99 / 96.5	-- / 118.5 / 116	-- / 131.5 / 129.5
Technical specifications acc. to IEC/DIN VDE			
• Max. load current in A / cross-section in mm <sup>2</sup>	232 / 95	309 / 150	415 / 240
• Maximum cross-section with comb (rigid/flexible) in mm <sup>2</sup>	--	150 / 120	240 / 185
• Rated impulse withstand voltage in kV / pollution degree	8 / 3		
• Overvoltage category / molded plastic group	III / I		
Connection capacities			
• Flexible with end sleeve without/with plastic sleeve in mm <sup>2</sup>		50 ... 150 / 50 ... 150	70 ... 185 / 70 ... 185
Multi-conductor connection (two conductors of same cross-section)			
• Rigid/flexible in mm <sup>2</sup>	25 ... 35 / 25 ... 35	25 ... 50 / 35 ... 50	35 ... 95 / 50 ... 95
• Flexible with end sleeve, without plastic sleeve in mm <sup>2</sup>	16 ... 35	25 ... 50	35 ... 50
Stripped length in mm	30	40	
Plug gauge (IEC 60947-1)	B12	B14	B15
Screw thread	--	M10	
Tightening torque in Nm	--	25 ... 30	
Clamping point: screw thread / tightening torque in Nm	M8 / 15 ... 20 (hexagon socket-head screw)	--	--
Fixing: screw thread / tightening torque in Nm	M8 / 15 ... 20 (hexagon socket-head screw)	--	--
Molded plastic type	PA		
• Flammability class acc. to UL 94	V0		
Approval data (UL/cUL and CSA)			
• Rated voltage / rated current / conductor sizes			
- UL/cUL: V/A/AWG	2 ... 4 / 0	600 / 285 / 2 AWG - 300 kcmil	600 / 380 / 00 - 500 kcmil
- CSA: V/A/AWG	2 ... 4 / 0	600 / 275 / 2 AWG - 300 kcmil	600 / 400 / 0 - 500 kcmil
Support rails/protective conductor busbars	See section "Support rails" on page 1/3	--	





# 8WH1 Screw Terminals

## 8WH high-current terminals

### Selection and ordering data

Version	Order No.	MOQ*
<b>Terminal size 50 mm<sup>2</sup></b>		
 <p>8WH1 000-0AN00</p> <p><b>High-current terminals, terminal size 50 mm<sup>2</sup></b></p> <ul style="list-style-type: none"> <li>Enclosed at both ends</li> <li>Terminal width 20 mm</li> <li>C<sup>UL</sup>us</li> <li>IEC 60947-7-1                             <ul style="list-style-type: none"> <li>Rigid 16 ... 50 mm<sup>2</sup></li> <li>Flexible 25 ... 50 mm<sup>2</sup></li> <li>AWG 6-0</li> <li>I = 150 A</li> <li>U = 1000 V</li> </ul> </li> </ul> <p>Versions</p> <ul style="list-style-type: none"> <li>Gray</li> <li>Blue</li> </ul>	<p>8WH1 000-0AN00</p> <p>8WH1 000-0AN01</p>	<p>10 units</p> <p>10 units</p>
 <p>8WH1 000-0CN07</p> <p><b>High-current PE terminals, terminal size 50 mm<sup>2</sup></b></p> <ul style="list-style-type: none"> <li>Green/yellow</li> <li>Enclosed at both ends</li> <li>Terminal width 20 mm</li> <li>C<sup>UL</sup>us</li> <li>IEC 60947-7-1                             <ul style="list-style-type: none"> <li>Rigid 16 ... 50 mm<sup>2</sup></li> <li>Flexible 25 ... 50 mm<sup>2</sup></li> <li>AWG 6-0</li> <li>I = 150 A</li> <li>U = 1000 V</li> </ul> </li> </ul>	<p>8WH1 000-0CN07</p>	<p>10 units</p>
<b>Terminal size 95 mm<sup>2</sup></b>		
 <p>8WH1 000-0AQ00</p> <p><b>High-current terminals, terminal size 95 mm<sup>2</sup></b></p> <ul style="list-style-type: none"> <li>Enclosed at both ends</li> <li>Terminal width 25 mm</li> <li>C<sup>UL</sup>us</li> <li>IEC 60947-7-1                             <ul style="list-style-type: none"> <li>Rigid 25 ... 95 mm<sup>2</sup></li> <li>Flexible 35 ... 95 mm<sup>2</sup></li> <li>AWG 4-000</li> <li>I = 232 A</li> <li>U = 1000 V</li> </ul> </li> </ul> <p>Versions</p> <ul style="list-style-type: none"> <li>Gray</li> <li>Blue</li> </ul>	<p>8WH1 000-0AQ00</p> <p>8WH1 000-0AQ01</p>	<p>10 units</p> <p>10 units</p>
 <p>8WH1 000-0CQ07</p> <p><b>High-current PE terminals, terminal size 95 mm<sup>2</sup></b></p> <ul style="list-style-type: none"> <li>Green/yellow</li> <li>Enclosed at both ends</li> <li>Terminal width 25 mm</li> <li>C<sup>UL</sup>us</li> <li>IEC 60947-7-1                             <ul style="list-style-type: none"> <li>Rigid 25 ... 95 mm<sup>2</sup></li> <li>Flexible 35 ... 95 mm<sup>2</sup></li> <li>AWG 4-000</li> <li>I = 232 A</li> <li>U = 1000 V</li> </ul> </li> </ul>	<p>8WH1 000-0CQ07</p>	<p>10 units</p>
 <p>8WA1 010-1PQ00</p> <p><b>High-current PE terminals and high-current PEN terminals, terminal size 95mm<sup>2</sup>, two screw terminals</b></p> <ul style="list-style-type: none"> <li>Bare</li> <li>For I = 232 A</li> <li>Mounting width 16 mm</li> <li>Terminal height 63 mm</li> <li>Terminal length 75 mm</li> <li>For 35 mm x 15 mm standard mounting rail only</li> </ul> <p>Note</p> <p>8WH accessories do not match this terminal.</p>	<p>8WA1 010-1PQ00</p>	<p>5 units</p>
<b>Terminal size 150 mm<sup>2</sup></b>		
 <p>8WH1 000-0AS00</p> <p><b>High-current terminals, terminal size 150 mm<sup>2</sup></b></p> <ul style="list-style-type: none"> <li>Enclosed at both ends</li> <li>Terminal width 31 mm</li> <li>C<sup>UL</sup>us</li> <li>IEC 60947-7-1                             <ul style="list-style-type: none"> <li>Rigid 35 ... 150 mm<sup>2</sup></li> <li>Flexible 50 ... 150 mm<sup>2</sup></li> <li>AWG 2-300</li> <li>I = 309 A</li> <li>U = 1000 V</li> </ul> </li> </ul> <p>Versions</p> <ul style="list-style-type: none"> <li>Gray</li> <li>Blue</li> </ul>	<p>8WH1 000-0AS00</p> <p>8WH1 000-0AS01</p>	<p>10 units</p> <p>10 units</p>

\* You can order this quantity or a multiple thereof.

Version	Order No.	MOQ*
<b>Terminal size 240 mm<sup>2</sup></b>		
 <p>8WH1 000-0AU00</p>	<p><b>High-current terminals, terminal size 240 mm<sup>2</sup></b></p> <ul style="list-style-type: none"> <li>Enclosed at both ends</li> <li>Terminal width 36 mm</li> <li>Combs</li> <li>IEC 60947-7-1                             <ul style="list-style-type: none"> <li>Rigid 70 ... 240 mm<sup>2</sup></li> <li>Flexible 70 ... 240 mm<sup>2</sup></li> <li>AWG 00-500</li> <li><math>I = 415</math> A</li> <li><math>U = 1000</math> V</li> </ul> </li> </ul> <p>Versions</p> <ul style="list-style-type: none"> <li>Gray</li> <li>Blue</li> </ul>	<p>8WH1 000-0AU00 10 units</p> <p>8WH1 000-0AU01 10 units</p>
<b>Accessories</b>		
 <p>8WH9 120-0AA00</p>	<p><b>Tap-off terminals</b></p> <ul style="list-style-type: none"> <li>When wiring a pick-off with a smaller cross-section, observe the overload and short-circuit strength specified in VDE 0100 Part 430</li> <li><math>I_{max}</math>: 57 A</li> <li>Cross-section: 10 mm<sup>2</sup></li> </ul> <p>Versions</p> <ul style="list-style-type: none"> <li>For terminal size 50 mm<sup>2</sup></li> <li>For terminal size 95 mm<sup>2</sup></li> <li>For terminal size 150 ... 240 mm<sup>2</sup></li> </ul>	<p>8WH9 120-0AA00 10 units</p> <p>8WH9 120-0BA00 10 units</p> <p>8WH9 120-0CA00 10 units</p>
 <p>8WH9 020-3AA00</p>	<p><b>Combs</b></p> <ul style="list-style-type: none"> <li>Totally insulated</li> <li>Fitted in the clamping sleeve and latched with the terminal enclosure</li> </ul> <p>Versions</p> <ul style="list-style-type: none"> <li>For terminal size 95 mm<sup>2</sup>, <math>I_{max}</math>: 232 A                             <ul style="list-style-type: none"> <li>2-pole</li> <li>3-pole</li> </ul> </li> <li>For terminal size 150 mm<sup>2</sup>, <math>I_{max}</math>: 232 A                             <ul style="list-style-type: none"> <li>2-pole</li> <li>3-pole</li> </ul> </li> <li>For terminal size 240 mm<sup>2</sup>, <math>I_{max}</math>: 320 A                             <ul style="list-style-type: none"> <li>2-pole</li> <li>3-pole</li> </ul> </li> </ul>	<p>8WH9 020-3AA00 10 units</p> <p>8WH9 020-3BA00 10 units</p> <p>8WH9 020-3CA00 10 units</p> <p>8WH9 020-3DA00 10 units</p> <p>8WH9 020-3EA00 10 units</p> <p>8WH9 020-3FA00 10 units</p>
 <p>8WH9 020-3MA00</p>	<p><b>Insertion profiles</b></p> <p>Evens out the prismatic sleeve base when using flat conductors</p> <p>Versions</p> <ul style="list-style-type: none"> <li>For terminal size 50 mm<sup>2</sup></li> <li>For terminal size 95 mm<sup>2</sup></li> <li>For terminal sizes 150 and 240 mm<sup>2</sup></li> </ul>	<p>8WH9 020-3MA00 10 units</p> <p>8WH9 020-3NA00 10 units</p> <p>8WH9 020-3PA00 10 units</p>
 <p>8WH9 020-6HC00</p>	<p><b>Permanent links, for terminal size 50 mm<sup>2</sup></b></p> <ul style="list-style-type: none"> <li>For cross links</li> <li>Screw heads with insulating collar</li> <li>Remove partition first</li> <li><math>I_{max} = 150</math> A</li> </ul> <p>Versions</p> <ul style="list-style-type: none"> <li>2-pole</li> <li>3-pole</li> </ul>	<p>8WH9 020-6HC00 10 units</p> <p>8WH9 020-6HD00 10 units</p>

Note:

For general accessories for 8WH terminal blocks, [see chapter 8](#).

# 8WH1 Screw Terminals

## 8WH shield terminals

### Overview



In industrial process engineering, a high interference immunity is required for electrical measuring and control equipment. It is a decisive factor in the availability of industrial equipment. When designing low-interference systems, great importance is placed on cable shielding and the respective shield ground. The critical point is where the cable shield is connected to the enclosure ground. The connection should have a low resistance and a low inductive reactance, while being quick and easy to establish. The shield terminals are ideally suited for this purpose and can be used with all common cable shields.

The effectiveness of cable shields depends to a large extent on the contact quality of the shield connection. The shield terminals have a large, low-impedance contact area with the shield, which reduces the voltage drop across it. Connected at one end only, shields can help reduce only low-frequency, capacitive interference, such as that caused by high-voltage installations. To pro-

tect from the much more common inductive interference signals, the cable shield must be connected at both ends.

However, differences in the ground potential can cause a compensating current to flow through the cable shield.

To reduce this interference current, it is advisable to connect the shield at several points along its length. The shorter the spaces between the clamping points, the smaller the compensating currents in the cable shield. In systems where safety is especially important, triaxial shields are used. These consist of two braids that are insulated from each other, with the outer shield connected at both ends and the inner one at only one end. With this arrangement, the equipotential bonding currents and the inductive interference are conducted through the outer shield, and the capacitive interference dissipated through the inner shield.

Depending on the length of the terminal strip, two or more support brackets are fitted, which provide both an electrical and a mechanical connection from the busbar to the support rail and therefore to the enclosure ground. The shield terminal is simply fitted to the busbar after all wires have been connected.

A spring-loaded pressure plate regulates the force applied to the cable to ensure an optimum contact with the busbar at all times.

If the cable shield is to be connected at another point of the control cabinet instead of directly in front of the terminal strip, we recommend using support brackets made of molded plastic.

### Technical specifications

	8WH9 130-0KA00	8WH9 130-0LA00	8WH9 130-0MA00	8WH9 130-0NA00	8WH9 130-0PA00
Dimensions	<a href="#">See dimensional drawing</a>	<a href="#">See dimensional drawing</a>	<a href="#">See dimensional drawing</a>	<a href="#">See dimensional drawing</a>	<a href="#">See dimensional drawing</a>
Contact resistance in mΩ		< 1			
Connection data					
• Diameter	2 ... 5	3 ... 8	3 ... 14	3 ... 20	20 ... 35
• Tightening torque in Nm	0.4	0.6	0.8	0.8	1.5 ... 1.8





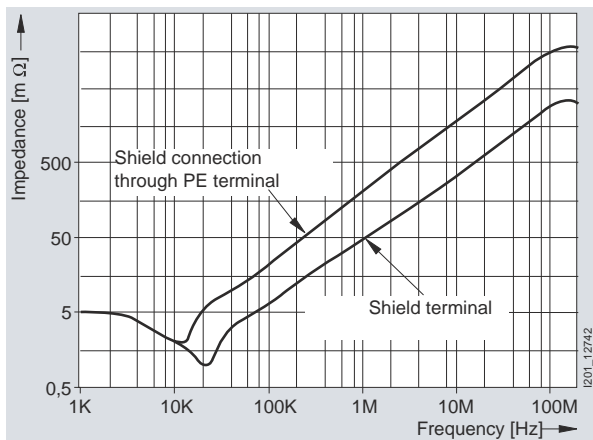

	8WH9 130-0AA00	8WH9 130-0BA00	8WH9 130-0CA00	8WH9 130-0DA00
Dimensions	<a href="#">See dimensional drawing</a>	<a href="#">See dimensional drawing</a>	<a href="#">See dimensional drawing</a>	<a href="#">See dimensional drawing</a>
Contact resistance in mΩ	The contact resistance is determined by the mounting area.			
Connection data				
• Diameter	3 ... 8	3 ... 14	3 ... 20	20 ... 35
• Tightening torque in Nm	0.6	0.8	0.8	1.5 ... 1.8



Comparison of shield connection through PE terminal and through shield terminal





### Selection and ordering data





Version	Order No.	MOQ*
<b>General details</b>		
<b>Note</b> <ul style="list-style-type: none"> <li>The shield terminals must not be used for strain relief.</li> <li>Support brackets have galvanic connections from the busbar to the support rail or to the mounting block.</li> <li>Busbar 10 mm × 3 mm</li> </ul>		
<b>Terminal diameter 3 ... 8 mm</b>		
<b>Shield terminal, terminal diameter 3 ... 8 mm</b>		
<b>Versions</b>		
 <p>8WH9 130-0AA0</p>	<ul style="list-style-type: none"> <li>For direct shield attachment on conductive mounting plate                             <ul style="list-style-type: none"> <li>Sheet thickness 1 ... 2 mm</li> </ul> </li> <li>For busbars</li> </ul>	<p><b>8WH9 130-0AA0</b> 10 units</p>
 <p>8WH9 130-0LA00</p>		<p><b>8WH9 130-0LA00</b> 10 units</p>
<b>Terminal diameter 3 ... 14 mm</b>		
<b>Shield terminal, terminal diameter 3 ... 14 mm</b>		
<b>Versions</b>		
 <p>8WH9 130-0BA00</p>	<ul style="list-style-type: none"> <li>For direct shield attachment on conductive mounting plate                             <ul style="list-style-type: none"> <li>Sheet thickness 1 ... 2 mm</li> </ul> </li> <li>For busbars</li> </ul>	<p><b>8WH9 130-0BA00</b> 10 units</p>
 <p>8WH9 130-0MA00</p>		<p><b>8WH9 130-0MA00</b> 10 units</p>

\* You can order this quantity or a multiple thereof.

# 8WH1 Screw Terminals

## 8WH shield terminals

Version	Order No.	MOQ*
<b>Terminal diameter 3 ... 20 mm</b>		
 <p>8WH9 130-0CA00</p>	<p><b>Shield terminal, terminal diameter 3 ... 20 mm</b></p> <p>Versions</p> <ul style="list-style-type: none"> <li>• For direct shield attachment on conductive mounting plate - Sheet thickness 1 ... 2 mm</li> <li>• For busbars</li> </ul>	
 <p>8WH9 130-0NA00</p>	<p><b>8WH9 130-0CA00</b></p>	<p>10 units</p>
<p><b>8WH9 130-0NA00</b></p>	<p>10 units</p>	
<b>Terminal diameter 20 ... 35 mm</b>		
 <p>8WH9 130-0DA00</p>	<p><b>Shield terminal, terminal diameter 20 ... 35 mm</b></p> <p>Versions</p> <ul style="list-style-type: none"> <li>• For direct shield attachment on conductive mounting plate - Sheet thickness 1 ... 2 mm</li> <li>• For busbars</li> </ul>	
 <p>8WH9 130-0PA00</p>	<p><b>8WH9 130-0DA00</b></p>	<p>50 units</p>
<p><b>8WH9 130-0PA00</b></p>	<p>10 units</p>	

Version	Order No.	MOQ*
<b>Accessories</b>		
 8WH9 140-0DA00	<b>8WH9 140-0DA00</b> 10 units  <b>8WH9 140-0BA00</b> 10 units  <b>8WH9 140-0CA00</b> 10 units	
 8WH9 140-0BA00		
 8WH9 140-0CA00		
 8WA2 842		
<b>Support brackets</b> Versions <ul style="list-style-type: none"> <li>• For terminal cross-section 8 to 35 mm<sup>2</sup>, made of molded plastic and conductive connection                             <ul style="list-style-type: none"> <li>- With retaining screw</li> <li>- For 10 x 3 mm busbars</li> </ul> </li> <li>• For terminal diameter 8 to 20 mm, for mounting rail with clearance of approx. 30 mm to the busbar                             <ul style="list-style-type: none"> <li>- For 10 x 3 mm busbars</li> </ul> </li> <li>• For terminal diameter 8 to 20 mm, for mounting rail with clearance of approx. 65 mm to the busbar                             <ul style="list-style-type: none"> <li>- For 10 x 3 mm busbars</li> </ul> </li> </ul>		
<b>N-busbars, 10 mm x 3 mm</b> <ul style="list-style-type: none"> <li>• Copper, aluminum</li> <li>• 1000 mm long</li> </ul>	<b>8WA2 842</b>	1 unit

Note:

For general accessories for 8WH terminal blocks, [see chapter 8](#).

\* You can order this quantity or a multiple thereof.

# 8WH1 Screw Terminals

## 8WH shield terminals

### Dimensional drawings

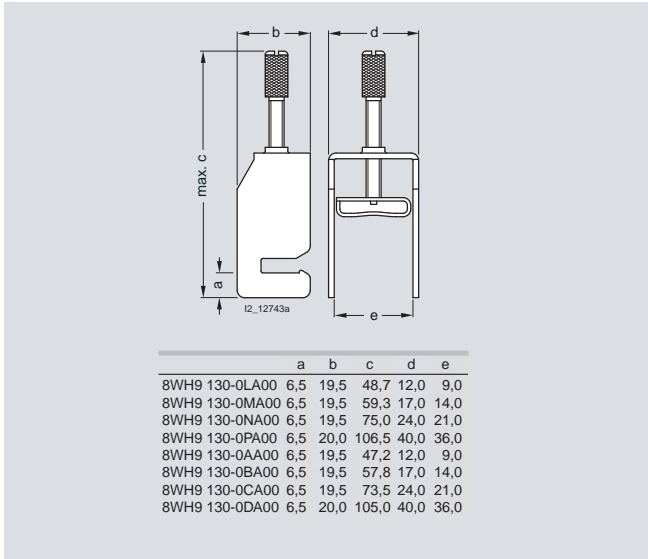

Shield terminals

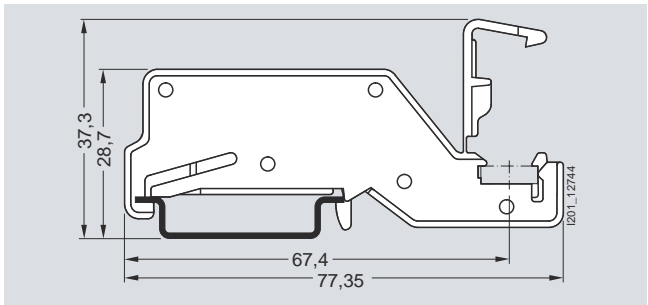

8WH9 140-0BA00

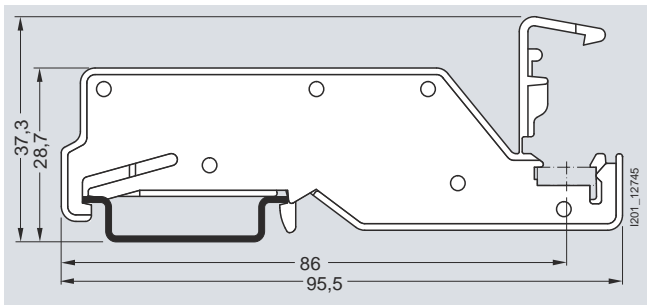

8WH9 140-0CA00

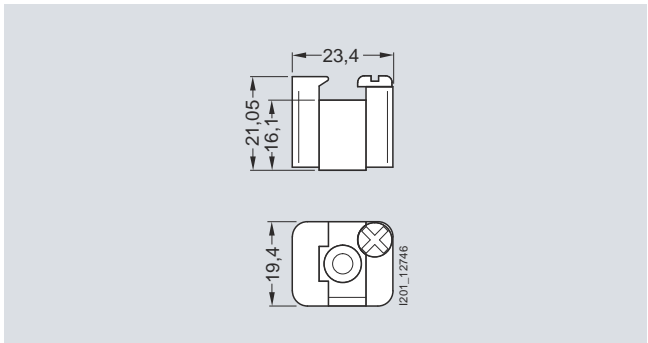

8WH9 140-0DA00

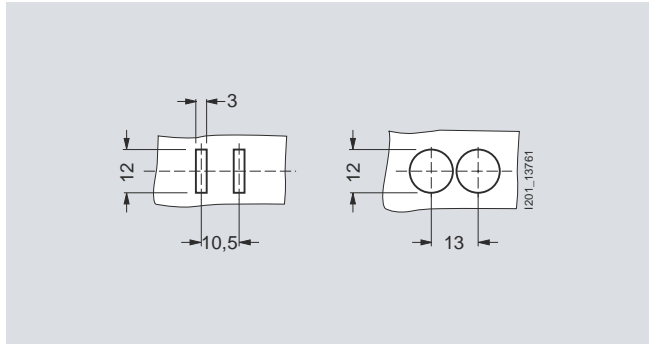

Punching template and drill plan for 8WH9 130-0AA00

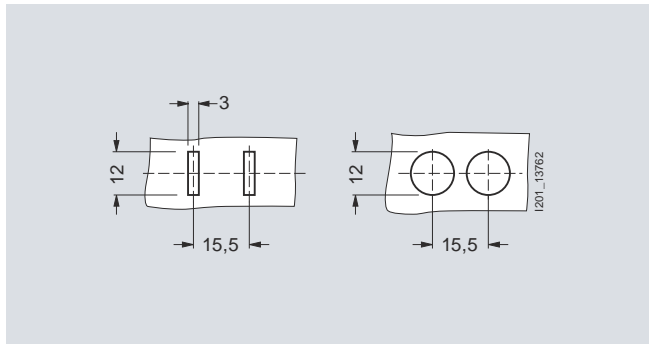

Punching template and drill plan for 8WH9 130-0BA00

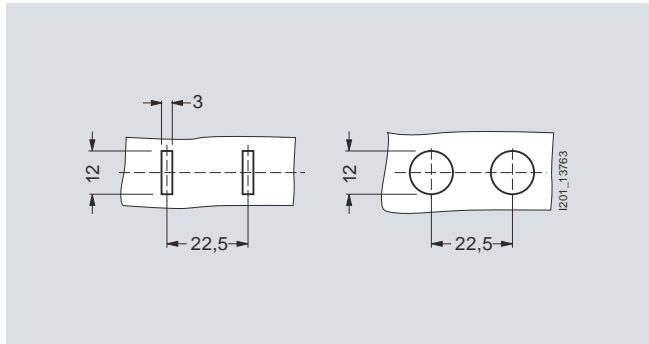

Punching template and drill plan for 8WH9 130-0CA00

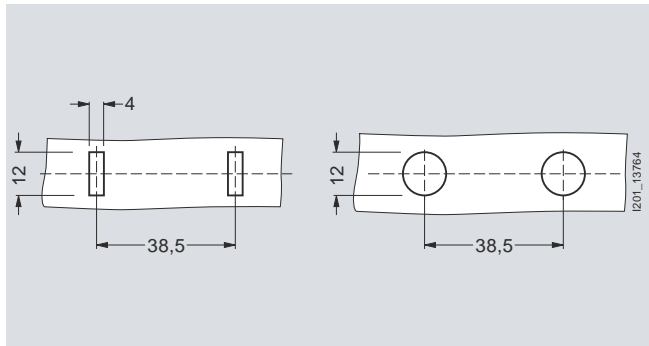

Punching template and drill plan for 8WH9 130-0DA00

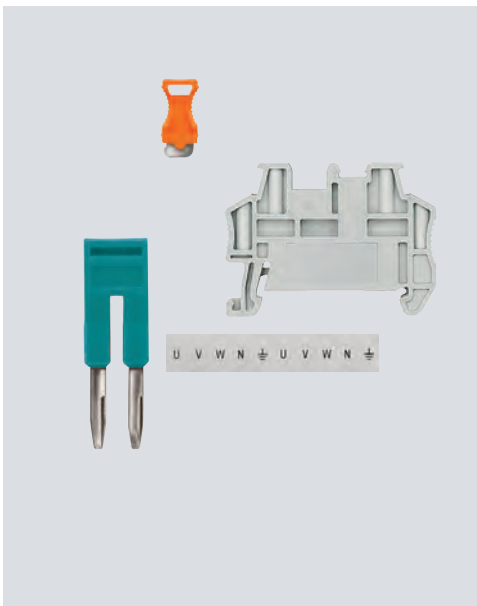

8/2 **Accessories for labeling system**

8/3 **Standard labeling system**

8/8 **Mounting accessories**

### More technical product information:

Service&Support Portal:  
[www.support.automation.siemens.com](http://www.support.automation.siemens.com)

Product List:  
Technical specifications

Entry List:  
Updates / Downloads / FAQ /  
Manuals / Operating instructions /  
Characteristic curves / Certificates

# Accessories for 8WH Terminal Blocks

## Accessories for labeling system

### Selection and ordering data

#### Accessories for ALPHA FIX PRINT printer labeling systems

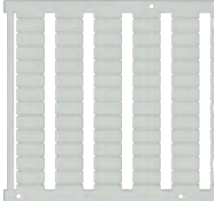
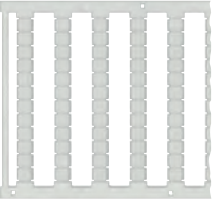
Version	Order No.	MOQ*
 <p><b>Fluid cartridges, for ALPHA FIX PRINT printers</b> Black</p> <p>8WH9 060-6BA08</p>	<b>8WH9 060-6BA08</b>	1 unit
 <p><b>Labels, front, for labeling 8WH terminal blocks using the ALPHA FIX PRINT printer</b></p> <p>Versions</p> <ul style="list-style-type: none"> <li>• 4.2 mm wide</li> <li>• 5.2 mm wide</li> <li>• 6.2 mm wide</li> <li>• 8.2 mm wide</li> <li>• 10.2 mm wide</li> <li>• 12.2 mm wide</li> <li>• 16.2 mm wide</li> </ul> <p>8WH8 202-1AA05</p>	<p><b>8WH8 202-1AA05</b></p> <p><b>8WH8 202-2AA05</b></p> <p><b>8WH8 202-3AA05</b></p> <p><b>8WH8 202-4AA05</b></p> <p><b>8WH8 202-5AA05</b></p> <p><b>8WH8 202-6AA05</b></p> <p><b>8WH8 202-7AA05</b></p>	<p>1200 units</p> <p>960 units</p> <p>800 units</p> <p>560 units</p> <p>480 units</p> <p>400 units</p> <p>320 units</p>
 <p><b>Labels, flat, for labeling 8WH terminal blocks using the ALPHA FIX PRINT printer</b></p> <p>Versions</p> <ul style="list-style-type: none"> <li>• 4.2 mm wide</li> <li>• 5.2 mm wide</li> <li>• 6.2 mm wide</li> <li>• 8.2 mm wide</li> <li>• 10.2 mm wide</li> <li>• 12.2 mm wide</li> <li>• 16.2 mm wide</li> </ul> <p>8WH8 203-1AA05</p>	<p><b>8WH8 203-1AA05</b></p> <p><b>8WH8 203-2AA05</b></p> <p><b>8WH8 203-3AA05</b></p> <p><b>8WH8 203-4AA05</b></p> <p><b>8WH8 203-5AA05</b></p> <p><b>8WH8 203-6AA05</b></p> <p><b>8WH8 203-7AA05</b></p>	<p>1200 units</p> <p>960 units</p> <p>800 units</p> <p>560 units</p> <p>480 units</p> <p>400 units</p> <p>320 units</p>



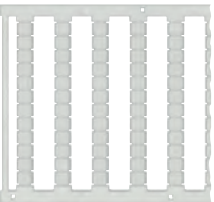

#### Accessories for plotter labeling system

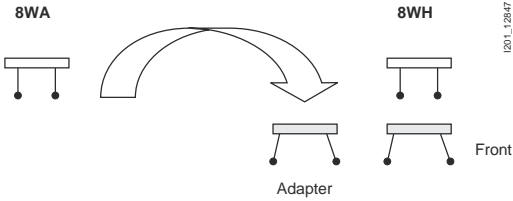
Version	Order No.	MOQ*
 <p><b>Labels, for plotter system</b></p> <p>Versions</p> <ul style="list-style-type: none"> <li>• Front <ul style="list-style-type: none"> <li>- For terminal width 4.2 mm</li> <li>- For terminal width 5.2 and 6.2 mm</li> <li>- For terminal width 8.2, 10, 12 and 16 mm</li> </ul> </li> <li>• Flat <ul style="list-style-type: none"> <li>- For terminal width 4.2, 5.2, 6.2, 8.2 and 10 mm</li> <li>- For terminal width 12 and 16 mm</li> </ul> </li> </ul> <p>Note</p> <p>The labels can only be printed using the plotter, or they can be written by hand.</p> <p>8WH8 113-1AA05</p>	<p><b>8WH8 112-1AA05</b></p> <p><b>8WH8 112-2AA05</b></p> <p><b>8WH8 112-4AA05</b></p> <p><b>8WH8 113-1AA05</b></p> <p><b>8WH8 113-6AA05</b></p>	<p>1024 units</p> <p>1400 units</p> <p>1000 units</p> <p>2000 units</p> <p>1080 units</p>

#### Adapters for 8WA labels

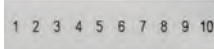
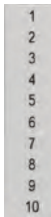
Version	Order No.	MOQ*
 <p><b>Adapters, for inscription of 8WA labels</b> 5 × 20 units</p> <p>8WH9 060-4AA00</p>	<b>8WH9 060-4AA00</b>	100 units

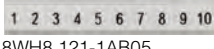



### Selection and ordering data

	Version	Order No.	MOQ*
	<b>Labels, front, for terminal width 4.2 mm and terminal size 1.5 mm<sup>2</sup> (excl. 8WH3), horizontal inscription</b> Versions • Incremental numbering - 1 ... 10 (10x) - 11 ... 20 (10x) - 21 ... 30 (10x) - 31 ... 40 (10x) - 41 ... 50 (10x) - 51 ... 60 (10x) - 61 ... 70 (10x) - 71 ... 80 (10x) - 81 ... 90 (10x) - 91 ... 100 (10x) • Custom inscription	<b>8WH8 120-1A□□□</b> ▲▲▲ <b>B05</b> <b>B15</b> <b>B25</b> <b>B35</b> <b>B45</b> <b>B55</b> <b>B65</b> <b>B75</b> <b>B85</b> <b>C05</b>	100 units
8WH8 120-1AB05		<b>8WH8 120-1XA05</b>	100 units
	<b>Labels, front, for terminal width 4.2 mm and terminal size 1.5 mm<sup>2</sup> (excl. 8WH3), vertical inscription</b> Versions • Incremental numbering - 1 ... 10 (10x) - 11 ... 20 (10x) - 21 ... 30 (10x) - 31 ... 40 (10x) • Custom inscription	<b>8WH8 140-1A□□□</b> ▲▲▲ <b>B05</b> <b>B15</b> <b>B25</b> <b>B35</b>	100 units
8WH8 140-1AB05		<b>8WH8 140-1XA05</b>	100 units
	<b>Labels, front, for terminal width 4.2 mm and terminal size 1.5 mm<sup>2</sup> (excl. 8WH3), blank</b>	<b>8WH8 110-1AA05</b>	100 units
8WH8 110-1AA05			
	<b>Labels, flat, for terminal width 4.2 mm and terminal size 1.5 mm<sup>2</sup> (excl. 8WH3), horizontal inscription</b> Versions • Incremental numbering - 1 ... 10 (10x) - 11 ... 20 (10x) - 21 ... 30 (10x) - 31 ... 40 (10x) - 41 ... 50 (10x) - 51 ... 60 (10x) - 61 ... 70 (10x) - 71 ... 80 (10x) - 81 ... 90 (10x) - 91 ... 100 (10x) • Custom inscription	<b>8WH8 121-1A□□□</b> ▲▲▲ <b>B05</b> <b>B15</b> <b>B25</b> <b>B35</b> <b>B45</b> <b>B55</b> <b>B65</b> <b>B75</b> <b>B85</b> <b>C05</b>	100 units
8WH8 121-1AB05		<b>8WH8 121-1XA05</b>	100 units
	<b>Labels, flat, for terminal width 4.2 mm and terminal size 1.5 mm<sup>2</sup> (excl. 8WH3), vertical inscription</b> Versions • Incremental numbering - 1 ... 10 (10x) - 11 ... 20 (10x) - 21 ... 30 (10x) - 31 ... 40 (10x) - 41 ... 50 (10x) - 51 ... 60 (10x) - 61 ... 70 (10x) - 71 ... 80 (10x) - 81 ... 90 (10x) - 91 ... 100 (10x) • Custom inscription	<b>8WH8 141-1A□□□</b> ▲▲▲ <b>B05</b> <b>B15</b> <b>B25</b> <b>B35</b> <b>B45</b> <b>B55</b> <b>B65</b> <b>B75</b> <b>B85</b> <b>C05</b>	100 units
8WH8 141-1AB05		<b>8WH8 141-1XA05</b>	100 units
	<b>Labels, flat, for terminal width 4.2 mm and terminal size 1.5 mm<sup>2</sup> (excluding 8WH3), blank</b>	<b>8WH8 111-1AA05</b>	100 units
8WH8 111-1AA05			

\* You can order this quantity or a multiple thereof.

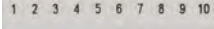
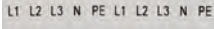
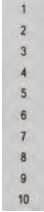
# Accessories for 8WH Terminal Blocks

## Standard labeling system

	Version	Order No.	MOQ*
 8WH8 120-2AB05	<b>Labels, front, for terminal width 5.2 mm and terminal size 2.5 mm<sup>2</sup> (8WH3: 1.5 mm<sup>2</sup>), horizontal inscription</b> Versions <ul style="list-style-type: none"> <li>• Incremental numbering                             <ul style="list-style-type: none"> <li>- 1 ... 10 (10x)</li> <li>- 11 ... 20 (10x)</li> <li>- 21 ... 30 (10x)</li> <li>- 31 ... 40 (10x)</li> <li>- 41 ... 50 (10x)</li> <li>- 51 ... 60 (10x)</li> <li>- 61 ... 70 (10x)</li> <li>- 71 ... 80 (10x)</li> <li>- 81 ... 90 (10x)</li> <li>- 91 ... 100 (10x)</li> </ul> </li> <li>• L1/L2/L3/N/PE</li> <li>• Custom inscription</li> </ul>	<b>8WH8 120-2A</b> □□□ ▲▲▲ B05 B15 B25 B35 B45 B55 B65 B75 B85 C05 A15 <b>8WH8 120-2XA05</b>	100 units
 8WH8 120-2AA15			
 8WH8 140-2AB05	<b>Labels, front, for terminal width 5.2 mm and terminal size 2.5 mm<sup>2</sup> (8WH3: 1.5 mm<sup>2</sup>), vertical inscription</b> Versions <ul style="list-style-type: none"> <li>• Incremental numbering                             <ul style="list-style-type: none"> <li>- 1 ... 10 (10x)</li> <li>- 11 ... 20 (10x)</li> <li>- 21 ... 30 (10x)</li> <li>- 31 ... 40 (10x)</li> <li>- 41 ... 50 (10x)</li> <li>- 51 ... 60 (10x)</li> <li>- 61 ... 70 (10x)</li> <li>- 71 ... 80 (10x)</li> <li>- 81 ... 90 (10x)</li> <li>- 91 ... 100 (10x)</li> </ul> </li> <li>• Custom inscription</li> </ul>	<b>8WH8 140-2A</b> □□□ ▲▲▲ B05 B15 B25 B35 B45 B55 B65 B75 B85 C05 <b>8WH8 140-2XA05</b>	100 units
 8WH8 110-2AA05	<b>Labels, front, for terminal width 5.2 mm and terminal size 2.5 mm<sup>2</sup> (8WH3: 1.5 mm<sup>2</sup>), blank</b>	<b>8WH8 110-2AA05</b>	100 units
 8WH8 121-2AB15	<b>Labels, flat, for terminal width 5.2 mm and terminal size 2.5 mm<sup>2</sup> (8WH3: 1.5 mm<sup>2</sup>), horizontal inscription</b> Versions <ul style="list-style-type: none"> <li>• Incremental numbering                             <ul style="list-style-type: none"> <li>- 1 ... 10 (10x)</li> <li>- 11 ... 20 (10x)</li> <li>- 21 ... 30 (10x)</li> <li>- 31 ... 40 (10x)</li> <li>- 41 ... 50 (10x)</li> <li>- 51 ... 60 (10x)</li> <li>- 61 ... 70 (10x)</li> <li>- 71 ... 80 (10x)</li> <li>- 81 ... 90 (10x)</li> <li>- 91 ... 100 (10x)</li> </ul> </li> <li>• Custom inscription</li> </ul>	<b>8WH8 121-2A</b> □□□ ▲▲▲ B05 B15 B25 B35 B45 B55 B65 B75 B85 C05 <b>8WH8 121-2XA05</b>	100 units
 8WH8 141-2AB15	<b>Labels, flat, for terminal width 5.2 mm and terminal size 2.5 mm<sup>2</sup> (8WH3: 1.5 mm<sup>2</sup>), vertical inscription</b> Versions <ul style="list-style-type: none"> <li>• Incremental numbering                             <ul style="list-style-type: none"> <li>- 1 ... 10 (10x)</li> <li>- 11 ... 20 (10x)</li> <li>- 21 ... 30 (10x)</li> <li>- 31 ... 40 (10x)</li> <li>- 41 ... 50 (10x)</li> <li>- 51 ... 60 (10x)</li> <li>- 61 ... 70 (10x)</li> <li>- 71 ... 80 (10x)</li> <li>- 81 ... 90 (10x)</li> <li>- 91 ... 100 (10x)</li> </ul> </li> <li>• Custom inscription</li> </ul>	<b>8WH8 141-2A</b> □□□ ▲▲▲ B05 B15 B25 B35 B45 B55 B65 B75 B85 C05 <b>8WH8 141-2XA05</b>	100 units
 8WH8 111-2AA05	<b>Labels, flat, for terminal width 5.2 mm and terminal size 2.5 mm<sup>2</sup> (8WH3: 1.5 mm<sup>2</sup>), blank</b>	<b>8WH8 111-2AA05</b>	100 units

# Accessories for 8WH Terminal Blocks



## Standard labeling system

Version	Order No.	MOQ*
<p>1 2 3 4 5 6 7 8 9 10</p> <p>8WH8 120-3AB05</p> <p>L1 L2 L3 N PE L1 L2 L3 N PE</p> <p>8WH8 120-3AA15</p> <p>U V W N ± U V W N ±</p> <p>8WH8 120-3AA25</p> <p><b>Labels, front, for terminal width 6.2 mm and terminal size 4 mm<sup>2</sup> (8WH3: 2.5 mm<sup>2</sup>), horizontal inscription</b></p> <p>Versions</p> <ul style="list-style-type: none"> <li>Incremental numbering           <ul style="list-style-type: none"> <li>- 1 ... 10 (10x)</li> <li>- 11 ... 20 (10x)</li> <li>- 21 ... 30 (10x)</li> <li>- 31 ... 40 (10x)</li> <li>- 41 ... 50 (10x)</li> <li>- 51 ... 60 (10x)</li> <li>- 61 ... 70 (10x)</li> <li>- 71 ... 80 (10x)</li> <li>- 81 ... 90 (10x)</li> <li>- 91 ... 100 (10x)</li> </ul> </li> <li>L1/L2/L3/N/PE</li> <li>U/V/W/N/grounding</li> <li>Custom inscription</li> </ul>	<p>8WH8 120-3A□□□</p> <p>▲▲▲</p> <p>B05 B15 B25 B35 B45 B55 B65 B75 B85 C05 A15 A25</p> <p>8WH8 120-3XA05</p>	<p>100 units</p> <p>100 units</p>
<p>1</p> <p>2</p> <p>3</p> <p>4</p> <p>5</p> <p>6</p> <p>7</p> <p>8</p> <p>9</p> <p>10</p> <p>8WH8 140-3AB05</p> <p><b>Labels, front, for terminal width 6.2 mm and terminal size 4 mm<sup>2</sup> (8WH3: 2.5 mm<sup>2</sup>), vertical inscription</b></p> <p>Versions</p> <ul style="list-style-type: none"> <li>Incremental numbering           <ul style="list-style-type: none"> <li>- 1 ... 10 (10x)</li> <li>- 11 ... 20 (10x)</li> <li>- 21 ... 30 (10x)</li> <li>- 31 ... 40 (10x)</li> <li>- 41 ... 50 (10x)</li> <li>- 51 ... 60 (10x)</li> <li>- 61 ... 70 (10x)</li> <li>- 71 ... 80 (10x)</li> <li>- 81 ... 90 (10x)</li> <li>- 91 ... 100 (10x)</li> </ul> </li> <li>Custom inscription</li> </ul>	<p>8WH8 140-3A□□□</p> <p>▲▲▲</p> <p>B05 B15 B25 B35 B45 B55 B65 B75 B85 C05</p> <p>8WH8 140-3XA05</p>	<p>100 units</p> <p>100 units</p>
<p>8WH8 110-3AA05</p> <p><b>Labels, front, for terminal width 6.2 mm and terminal size 4 mm<sup>2</sup> (8WH3: 2.5 mm<sup>2</sup>), blank</b></p>	<p>8WH8 110-3AA05</p>	<p>100 units</p>
<p>1 2 3 4 5 6 7 8 9 10</p> <p>8WH8 121-3AB05</p> <p><b>Labels, flat, for terminal width 6.2 mm and terminal size 4 mm<sup>2</sup> (8WH3: 2.5 mm<sup>2</sup>), horizontal inscription</b></p> <p>Versions</p> <ul style="list-style-type: none"> <li>Incremental numbering           <ul style="list-style-type: none"> <li>- 1 ... 10 (10x)</li> <li>- 11 ... 20 (10x)</li> <li>- 21 ... 30 (10x)</li> <li>- 31 ... 40 (10x)</li> <li>- 41 ... 50 (10x)</li> <li>- 51 ... 60 (10x)</li> <li>- 61 ... 70 (10x)</li> <li>- 71 ... 80 (10x)</li> <li>- 81 ... 90 (10x)</li> <li>- 91 ... 100 (10x)</li> </ul> </li> <li>Custom inscription</li> </ul>	<p>8WH8 121-3A□□□</p> <p>▲▲▲</p> <p>B05 B15 B25 B35 B45 B55 B65 B75 B85 C05</p> <p>8WH8 121-3XA05</p>	<p>100 units</p> <p>100 units</p>
<p>1</p> <p>2</p> <p>3</p> <p>4</p> <p>5</p> <p>6</p> <p>7</p> <p>8</p> <p>9</p> <p>10</p> <p>8WH8 141-3AB05</p> <p><b>Labels, flat, for terminal width 6.2 mm and terminal size 4 mm<sup>2</sup> (8WH3: 2.5 mm<sup>2</sup>), vertical inscription</b></p> <p>Versions</p> <ul style="list-style-type: none"> <li>Incremental numbering           <ul style="list-style-type: none"> <li>- 1 ... 10 (10x)</li> </ul> </li> <li>Custom inscription</li> </ul>	<p>8WH8 141-3AB05</p> <p>8WH8 141-3XA05</p>	<p>100 units</p> <p>100 units</p>
<p>8WH8 111-3AA05</p> <p><b>Labels, flat, for terminal width 6.2 mm and terminal size 4 mm<sup>2</sup> (8WH3: 2.5 mm<sup>2</sup>), blank</b></p>	<p>8WH8 111-3AA05</p>	<p>100 units</p>

\* You can order this quantity or a multiple thereof.



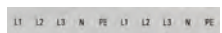

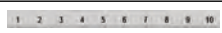
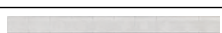



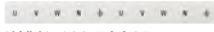

# Accessories for 8WH Terminal Blocks

## Standard labeling system

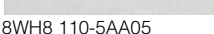
	Version	Order No.	MOQ*
 8WH8 120-4AB05	<b>Labels, front, for terminal width 8.2 mm and terminal size 6 mm<sup>2</sup>, horizontal inscription</b> Versions <ul style="list-style-type: none"> <li>• Incremental numbering               <ul style="list-style-type: none"> <li>- 1 ... 10 (10x)</li> <li>- 11 ... 20 (10x)</li> <li>- 21 ... 30 (10x)</li> <li>- 31 ... 40 (10x)</li> <li>- 41 ... 50 (10x)</li> <li>- 51 ... 60 (10x)</li> <li>- 61 ... 70 (10x)</li> <li>- 71 ... 80 (10x)</li> <li>- 81 ... 90 (10x)</li> <li>- 91 ... 100 (10x)</li> </ul> </li> <li>• L1/L2/L3/N/PE</li> <li>• Custom inscription</li> </ul>	<b>8WH8 120-4A</b> □□□ ▲▲▲ <b>B05</b> <b>B15</b> <b>B25</b> <b>B35</b> <b>B45</b> <b>B55</b> <b>B65</b> <b>B75</b> <b>B85</b> <b>C05</b> <b>A15</b> <b>8WH8 120-4XA05</b>	100 units
 8WH8 120-4AA15	<b>Labels, front, for terminal width 8.2 mm and terminal size 6 mm<sup>2</sup>, vertical inscription</b> Versions <ul style="list-style-type: none"> <li>• Incremental numbering               <ul style="list-style-type: none"> <li>- 1 ... 10 (10x)</li> <li>- 11 ... 20 (10x)</li> <li>- 21 ... 30 (10x)</li> </ul> </li> <li>• Custom inscription</li> </ul>	<b>8WH8 140-4A</b> □□□ ▲▲▲ <b>B05</b> <b>B15</b> <b>B25</b> <b>8WH8 140-4XA05</b>	100 units
 8WH8 140-4AB05	<b>Labels, front, for terminal width 8.2 mm and terminal size 6 mm<sup>2</sup>, blank</b>	<b>8WH8 110-4AA05</b>	100 units
 8WH8 121-4AB05	<b>Labels, flat, for terminal width 8.2 mm and terminal size 6 mm<sup>2</sup>, horizontal inscription</b> Versions <ul style="list-style-type: none"> <li>• Incremental numbering               <ul style="list-style-type: none"> <li>- 1 ... 10 (10x)</li> <li>- 11 ... 20 (10x)</li> <li>- 21 ... 30 (10x)</li> </ul> </li> <li>• Custom inscription</li> </ul>	<b>8WH8 121-4A</b> □□□ ▲▲▲ <b>B05</b> <b>B15</b> <b>B25</b> <b>8WH8 121-4XA05</b>	100 units
	<b>Labels, flat, for terminal width 8.2 mm and terminal size 6 mm<sup>2</sup>, vertical inscription</b> Versions <ul style="list-style-type: none"> <li>• Incremental numbering               <ul style="list-style-type: none"> <li>- 1 ... 10 (10x)</li> <li>- 11 ... 20 (10x)</li> <li>- 21 ... 30 (10x)</li> </ul> </li> <li>• Custom inscription</li> </ul>	<b>8WH8 141-4A</b> □□□ ▲▲▲ <b>B05</b> <b>B15</b> <b>B25</b> <b>8WH8 141-4XA05</b>	100 units
 8WH8 111-4AA05	<b>Labels, flat, for terminal width 8.2 mm and terminal size 6 mm<sup>2</sup>, blank</b>	<b>8WH8 111-4AA05</b>	100 units

# Accessories for 8WH Terminal Blocks

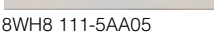
## Standard labeling system

Version	Order No.	MOQ*
 <p>8WH8 120-5AB05</p> <p><b>Labels, front, for terminal width 10 and 12 mm and terminal sizes 10 and 16 mm<sup>2</sup>, horizontal inscription</b></p> <p>Versions</p> <ul style="list-style-type: none"> <li>• Incremental numbering                             <ul style="list-style-type: none"> <li>- 1 ... 10 (10x)</li> <li>- 11 ... 20 (10x)</li> <li>- 21 ... 30 (10x)</li> <li>- 31 ... 40 (10x)</li> </ul> </li> <li>• L1/L2/L3/N/PE</li> <li>• U/V/W/N/grounding</li> <li>• Custom inscription</li> </ul>	<p>8WH8 120-5A□□□</p> <p>▲▲▲</p> <p>B05 B15 B25 B35</p> <p>A15 A25</p> <p>8WH8 120-5XA05</p>	<p>100 units</p> <p>100 units</p>
 <p>8WH8 120-5AA15</p> <p><b>Labels, front, for terminal width 10 and 12 mm and terminal sizes 10 and 16 mm<sup>2</sup>, horizontal inscription</b></p> <p>Versions</p> <ul style="list-style-type: none"> <li>• Incremental numbering                             <ul style="list-style-type: none"> <li>- 1 ... 10 (10x)</li> <li>- 11 ... 20 (10x)</li> <li>- 21 ... 30 (10x)</li> <li>- 31 ... 40 (10x)</li> </ul> </li> <li>• Custom inscription</li> </ul>	<p>8WH8 140-5A□□□</p> <p>▲▲▲</p> <p>B05 B15 B25 B35</p> <p>8WH8 140-5XA05</p>	<p>100 units</p> <p>100 units</p>
 <p>8WH8 120-5AA25</p> <p><b>Labels, front, for terminal width 10 and 12 mm and terminal sizes 10 and 16 mm<sup>2</sup>, vertical inscription</b></p> <p>Versions</p> <ul style="list-style-type: none"> <li>• Incremental numbering                             <ul style="list-style-type: none"> <li>- 1 ... 10 (10x)</li> <li>- 11 ... 20 (10x)</li> <li>- 21 ... 30 (10x)</li> <li>- 31 ... 40 (10x)</li> </ul> </li> <li>• Custom inscription</li> </ul>	<p>8WH8 110-5AA05</p>	<p>100 units</p>
 <p>8WH8 140-5AB05</p> <p><b>Labels, front, for terminal width 10 and 12 mm and terminal sizes 10 and 16 mm<sup>2</sup>, vertical inscription</b></p> <p>Versions</p> <ul style="list-style-type: none"> <li>• Incremental numbering                             <ul style="list-style-type: none"> <li>- 1 ... 10 (10x)</li> <li>- 11 ... 20 (10x)</li> <li>- 21 ... 30 (10x)</li> <li>- 31 ... 40 (10x)</li> </ul> </li> <li>• Custom inscription</li> </ul>	<p>8WH8 121-5A□□□</p> <p>▲▲▲</p> <p>B05 B15 B25</p> <p>8WH8 121-5XA05</p>	<p>100 units</p> <p>100 units</p>
 <p>8WH8 110-5AA05</p> <p><b>Labels, flat, for terminal width 10 and 12 mm and terminal sizes 10 and 16 mm<sup>2</sup>, horizontal inscription</b></p> <p>Versions</p> <ul style="list-style-type: none"> <li>• Incremental numbering                             <ul style="list-style-type: none"> <li>- 1 ... 10 (10x)</li> <li>- 11 ... 20 (10x)</li> <li>- 21 ... 30 (10x)</li> </ul> </li> <li>• Custom inscription</li> </ul>	<p>8WH8 141-5AB05</p> <p>8WH8 141-5XA05</p>	<p>100 units</p> <p>100 units</p>
 <p>8WH8 121-5AB05</p> <p><b>Labels, flat, for terminal width 10 and 12 mm and terminal sizes 10 and 16 mm<sup>2</sup>, vertical inscription</b></p> <p>Versions</p> <ul style="list-style-type: none"> <li>• Incremental numbering                             <ul style="list-style-type: none"> <li>- 1 ... 10 (10x)</li> </ul> </li> <li>• Custom inscription</li> </ul>	<p>8WH8 111-5AA05</p>	<p>100 units</p>
 <p>8WH8 141-5AB05</p> <p><b>Labels, flat, for terminal width 10 and 12 mm and terminal sizes 10 and 16 mm<sup>2</sup>, blank</b></p>	<p>8WH8 120-7AA15</p> <p>Versions</p> <ul style="list-style-type: none"> <li>• L1/L2/L3/N/PE</li> <li>• Custom inscription</li> </ul>	<p>100 units</p> <p>100 units</p>
 <p>8WH8 141-5AB05</p> <p><b>Labels, front, for terminal width 16 mm and terminal size 35 mm<sup>2</sup>, horizontal inscription</b></p> <p>Versions</p> <ul style="list-style-type: none"> <li>• L1/L2/L3/N/PE</li> <li>• Custom inscription</li> </ul>	<p>8WH8 140-7XA05</p>	<p>100 units</p>
 <p>8WH8 111-5AA05</p> <p><b>Labels, front, for terminal width 16 mm and terminal size 35 mm<sup>2</sup>, vertical inscription, custom inscription</b></p>	<p>8WH8 110-7AA05</p>	<p>100 units</p>
 <p>8WH8 110-7AA05</p> <p><b>Labels, front, for terminal width 16 mm and terminal size 35 mm<sup>2</sup>, blank</b></p>	<p>8WH8 111-7AA05</p>	<p>100 units</p>
 <p>8WH8 110-7AA05</p> <p><b>Labels, flat, for terminal width 16 mm and terminal size 35 mm<sup>2</sup>, blank</b></p>		







\* You can order this quantity or a multiple thereof.



# Accessories for 8WH Terminal Blocks

## Mounting accessories

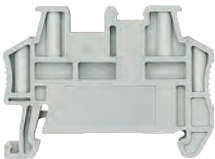
### Selection and ordering data

	Version	Order No.	MOQ*
	<b>Modular test plugs</b> For individual assembly of test plug connectors Versions	<b>8WH9 010-0DB02</b> <b>8WH9 010-0EB02</b> <b>8WH9 010-0FB02</b>	10 units 10 units 10 units
	<ul style="list-style-type: none"> <li>• For terminal width 4.2 mm and terminal size 1.5 mm<sup>2</sup> 1)</li> <li>• For terminal width 5.2 mm and terminal size 2.5 mm<sup>2</sup> 1)</li> <li>• For terminal width 6.2 mm and terminal size 6 mm<sup>2</sup> 1)</li> </ul> 1) excluding 8WH3		
	<b>Spacer plates</b> For leaving out single terminals for individual test plug assembly Versions	<b>8WH9 010-2AA02</b> <b>8WH9 010-2BA02</b> <b>8WH9 010-2CA02</b>	10 units 10 units 10 units
<ul style="list-style-type: none"> <li>• For terminal width 4.2 mm and terminal size 1.5 mm<sup>2</sup> 1)</li> <li>• For terminal width 5.2 mm and terminal size 2.5 mm<sup>2</sup> 1)</li> <li>• For terminal width 6.2 mm and terminal size 6 mm<sup>2</sup> 1)</li> </ul> 1) excl. 8WH3			
	<b>Terminal strip markers, for end retainers</b> <ul style="list-style-type: none"> <li>• Height-adjustable</li> <li>• For quick-fit end retainers</li> <li>• Facility for inscription with terminal strip marker or two labels, front, for terminal width 10.2 mm</li> <li>• Labeling field size: 20 x 8 mm</li> </ul>	<b>8WH9 150-1CA00</b>	100 units
	<b>Test adapters</b> <ul style="list-style-type: none"> <li>• For 4 mm Ø PS test plugs and 4 mm Ø safety test plugs</li> <li>• Makes contact in the bridge shaft</li> </ul>	<b>8WH9 010-0JB00</b>	10 units
	<b>Reducing combs</b> Versions	<b>8WH9 020-0CC10</b> <b>8WH9 020-0FC10</b> <b>8WH9 020-0AC10</b> <b>8WH9 020-0BC10</b> <b>8WH9 020-0EC10</b>  <b>8WH9 020-0DC10</b>	10 units 10 units 10 units 10 units 10 units  10 units
	<ul style="list-style-type: none"> <li>• For bridging of a through-type terminal, terminal size 2.5 or 4 mm<sup>2</sup> <ul style="list-style-type: none"> <li>- for a through-type terminal, terminal size 1.5 mm<sup>2</sup></li> <li>- for a through-type terminal, terminal size 6 mm<sup>2</sup></li> <li>- for a through-type terminal, terminal size 10 mm<sup>2</sup></li> <li>- for a through-type terminal, terminal size 16 mm<sup>2</sup></li> <li>- for a through-type terminal, terminal size 35 mm<sup>2</sup></li> </ul> </li> <li>• For bridging of a through-type terminal, terminal size 16 mm<sup>2</sup> <ul style="list-style-type: none"> <li>- for a through-type terminal, terminal size 35 mm<sup>2</sup></li> </ul> </li> </ul> Note Not for 8WH1 through-type terminals and 8WH3 insulation displacement terminals.		
	<b>Quick-fit end retainers</b> Facility for inscription with labels, front, for terminal width 5.2 mm and terminal strip marker	<b>8WH9 150-0CA00</b>	50 units
	<b>Screwdrivers</b> For opening spring-loaded terminals Versions	<b>8WH9 200-0AA00</b> <b>8WH9 200-0AB00</b> <b>8WH9 200-0AC00</b> <b>8WH9 200-0AD00</b>	10 units 10 units 10 units 10 units
	<ul style="list-style-type: none"> <li>• 0.4 x 2.5 mm</li> <li>• 0.6 x 3.5 mm</li> <li>• 0.8 x 4.0 mm</li> <li>• 1.0 x 5.5 mm</li> </ul>		

# Accessories for 8WH Terminal Blocks

## Mounting accessories









8WH9 020-6AC10

Version	Order No.	MOQ*
<b>Connecting combs</b>		
<b>Versions</b>	<b>Max. load current <math>I_{max}</math></b>	
<ul style="list-style-type: none"> <li>• For terminal width 4.2 mm and terminal size 1.5 mm<sup>2</sup> (excl. 8WH3)                             <ul style="list-style-type: none"> <li>- 2-pole</li> <li>- 3-pole</li> <li>- 4-pole</li> <li>- 5-pole</li> <li>- 10-pole</li> <li>- 20-pole</li> </ul> </li> </ul>	17.5 A	<ul style="list-style-type: none"> <li><b>8WH9 020-6AC10</b> 50 units</li> <li><b>8WH9 020-6AD10</b> 50 units</li> <li><b>8WH9 020-6AE10</b> 50 units</li> <li><b>8WH9 020-6AF10</b> 50 units</li> <li><b>8WH9 020-6AL10</b> 10 units</li> <li><b>8WH9 020-6AS10</b> 10 units</li> </ul>
<ul style="list-style-type: none"> <li>• For terminal width 5.2 mm and terminal size 2.5 mm<sup>2</sup> (for 8WH3: 1.5mm<sup>2</sup>)                             <ul style="list-style-type: none"> <li>- 2-pole</li> <li>- 3-pole</li> <li>- 4-pole</li> <li>- 5-pole</li> <li>- 10-pole</li> <li>- 20-pole</li> <li>- 50-pole</li> </ul> </li> </ul>	24 A	<ul style="list-style-type: none"> <li><b>8WH9 020-6BC10</b> 50 units</li> <li><b>8WH9 020-6BD10</b> 50 units</li> <li><b>8WH9 020-6BE10</b> 50 units</li> <li><b>8WH9 020-6BF10</b> 50 units</li> <li><b>8WH9 020-6BL10</b> 10 units</li> <li><b>8WH9 020-6BS10</b> 10 units</li> <li><b>8WH9 020-6BT10</b> 10 units</li> </ul>
<ul style="list-style-type: none"> <li>• For terminal width 6.2 mm and terminal size 4 mm<sup>2</sup> (for 8WH3: 2.5mm<sup>2</sup>)                             <ul style="list-style-type: none"> <li>- 2-pole</li> <li>- 3-pole</li> <li>- 4-pole</li> <li>- 5-pole</li> <li>- 10-pole</li> <li>- 20-pole</li> <li>- 50-pole</li> </ul> </li> </ul>	32 A	<ul style="list-style-type: none"> <li><b>8WH9 020-6CC10</b> 50 units</li> <li><b>8WH9 020-6CD10</b> 50 units</li> <li><b>8WH9 020-6CE10</b> 50 units</li> <li><b>8WH9 020-6CF10</b> 50 units</li> <li><b>8WH9 020-6CL10</b> 10 units</li> <li><b>8WH9 020-6CS10</b> 10 units</li> <li><b>8WH9 020-6CT10</b> 10 units</li> </ul>
<ul style="list-style-type: none"> <li>• For terminal width 8.2 mm and terminal size 6 mm<sup>2</sup> <ul style="list-style-type: none"> <li>- 2-pole</li> <li>- 3-pole</li> <li>- 4-pole</li> <li>- 5-pole</li> <li>- 10-pole</li> </ul> </li> </ul>	41 A	<ul style="list-style-type: none"> <li><b>8WH9 020-6DC10</b> 10 units</li> <li><b>8WH9 020-6DD10</b> 10 units</li> <li><b>8WH9 020-6DE10</b> 10 units</li> <li><b>8WH9 020-6DF10</b> 10 units</li> <li><b>8WH9 020-6DL10</b> 10 units</li> </ul>
<ul style="list-style-type: none"> <li>• For terminal width 10 mm and terminal size 10 mm<sup>2</sup>, 2-pole,</li> </ul>	57 A	<b>8WH9 020-6EC10</b> 10 units
<ul style="list-style-type: none"> <li>• For terminal width 12 mm and terminal size 16 mm<sup>2</sup>, 2-pole</li> </ul>	76 A	<b>8WH9 020-6FC10</b> 10 units
<ul style="list-style-type: none"> <li>• For terminal width 16 mm, terminal size 35 mm<sup>2</sup>, 2-pole</li> </ul>	101 A	<b>8WH9 020-6GC10</b> 10 units

\* You can order this quantity or a multiple thereof.

# Accessories for 8WH Terminal Blocks

## Mounting accessories

Version	Order No.	MOQ*
<b>Plug-in zone connectors, for isolating terminals</b>		
 8WH9 040-0DB04	<ul style="list-style-type: none"> <li>Isolating plugs</li> <li>- Orange</li> </ul>	8WH9 040-0DB04 50 units
 8WH9 020-8AB00	<ul style="list-style-type: none"> <li>Through-type connectors</li> <li>- Gray</li> <li>- <math>I_{max}</math>: 16 A</li> </ul>	8WH9 020-8AB00 50 units
 8WH9 040-3AB08	<ul style="list-style-type: none"> <li>Fused connectors</li> <li>- Black</li> <li>- <math>I_{max}</math>: 6.3 A</li> <li>- Facility for labeling with labels, flat, for terminal width 6.2 mm</li> <li>- G fuses 5 x 20 mm</li> </ul> <p>Versions</p> <ul style="list-style-type: none"> <li>- With LED display for 12 to 30 V, 1 ... 2.5 mA</li> <li>- With LED display for 30 to 60 V, 0.8 ... 2.0 mA</li> <li>- With LED display for 110 to 250 V, 0.5 ... 2.5 mA</li> <li>- Without LED display</li> </ul> <p>Note</p> <ul style="list-style-type: none"> <li>The G fuse holders must be selected according to the maximum power loss (heat dissipation) of the G fuse links. Depending on the application and method of installation, the heat rise conditions in closed fuse holders must be tested.</li> <li>Higher ambient temperatures represent an additional load for the fuse links. A shift in rated current should therefore be taken into account in such applications</li> </ul>	8WH9 040-3AB08 8WH9 040-3BB08 8WH9 040-3CB08 8WH9 040-3DB08 10 units 10 units 10 units 10 units
 8WH9 040-0BB00	<ul style="list-style-type: none"> <li>Component connectors</li> <li>- <math>I_{max}</math>: 6 A, depending on the power loss of the components, max. 1 W for single arrangement</li> <li>- Facility for labeling with labels, flat, for terminal width 5.2 mm</li> </ul>	8WH9 040-0BB00 10 units
 8WA2 867/8WA2 868/ 8WA2 870	<p><b>Feeder terminals, for N-busbars</b></p> <ul style="list-style-type: none"> <li>6 x 6 mm and 10 x 3 mm</li> <li>Bare</li> </ul> <p>Versions</p> <ul style="list-style-type: none"> <li>Rated uninterrupted current 32 A, for connection of up to 4 mm<sup>2</sup></li> <li>Rated uninterrupted current 76 A, for connection of up to 25 mm<sup>2</sup></li> <li>Rated uninterrupted current 125 A, for connection of up to 35 mm<sup>2</sup></li> </ul>	8WA2 867 8WA2 868 8WA2 870 50 units 50 units 50 units
 8WA2 842	<p><b>N-busbars, 10 mm x 3 mm</b></p> <ul style="list-style-type: none"> <li>Made of copper, tin-plated</li> <li>1000 mm long</li> </ul>	8WA2 842 1 unit

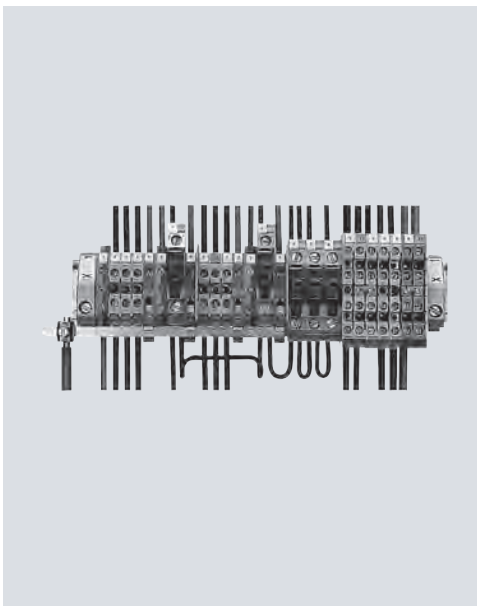

9/2	<b>Introduction</b>
9/3	<b>General data on 8WA</b>
9/9	<b>8WA through-type terminals<sup>1)</sup></b>
9/15	<b>8WA N-conductor isolating and branch terminals</b>
9/17	<b>8WA Insta or three-tier terminals</b>
9/19	<b>8WA two-tier terminals</b>
9/21	<b>8WA two-tier terminals with electronic components</b>
9/23	<b>8WA diode and isolating terminals</b>
9/24	<b>8WA terminals for components</b>
9/25	<b>8WA fuse terminals</b>
9/26	<b>8WA through-type terminals with soldered and plug-in connection</b>
9/27	<b>8WA measuring transformer terminals</b>
9/32	<b>8WA transformer terminals</b>

<sup>1)</sup> Also available as a PE version

### More technical product information:

Service&Support Portal:  
[www.support.automation.siemens.com](http://www.support.automation.siemens.com)











Product List:  
Technical specifications

Entry List:  
Updates / Downloads / FAQ /  
Manuals / Operating instructions /  
Characteristic curves / Certificates

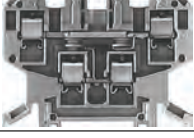
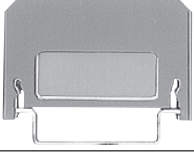
# 8WA1 Screw Terminals

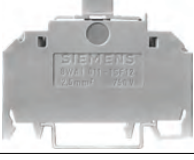
## Introduction

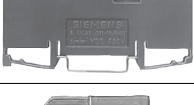
### Overview

	Devices	Page	Function
	8WA through-type terminals	9/9	Connection of incoming and outgoing conductors up to 70 mm <sup>2</sup>
	8WA N-conductor isolating and branch terminals	9/15	N-conductor isolating terminals connected to N-busbar 6 mm x 6 mm
	8WA Insta or three-tier terminals	9/17	These terminals have up to three terminal functions in a single enclosure and may also have an N-isolating terminal connection to an N-busbar 6 mm x 6 mm. They are optimized for distribution board applications in installation technology
	8WA two-tier terminals	9/19	Compact design of the terminal blocks, in which two connecting wires can be installed
	8WA two-tier terminals with electronic components	9/21	Terminal blocks with integrated diodes
	8WA diode and isolating terminals	9/23	Terminal blocks with integrated diodes or isolation for testing purposes
	8WA terminals for components	9/24	Terminals that enable installation of components in the circuit
	8WA fuse terminals	9/25	Terminals which can be used to protect control circuits, for example
	8WA through-type terminals with soldered and plug-in connection	9/26	Terminals with connection for soldered or plug-in connection
	8WA measuring transformer terminals	9/27	Measuring transformer terminals can be used for testing and isolating circuits in switchboards, control rooms, etc. without interrupting operation
	8WA transformer terminals	9/32	Optimized terminals for transformers and rectifiers

### Overview

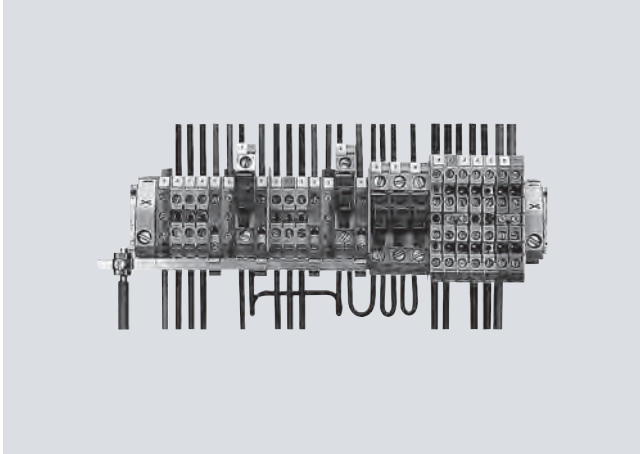

Terminal strips with different terminal blocks: 8WA1 011-1DG11 terminal blocks, 8WA1 011-1NG31 N-conductor isolating terminals with feeder terminal for N-busbar 6 × 6 mm, 8WA1 011-1PG00 PE terminals, 8WA1 011-1SF12 fuse terminals, and various two-tier terminals. The EN 50022-35-compliant standard mounting rail serves as the PE bar.

Terminal blocks are used for the space-saving connection of incoming and outgoing cables in switchboards and distribution boards.

#### Standards

EN 60664-1,  
EN 60999 and  
IEC 60 947-7-1 or  
IEC 60 947-7-2.

The terminals are finger-safe acc. to IEC 60529 and DIN EN 50274 (except for bare terminals and solder connections). Through-type terminals are resistant to earthquakes according to IEC 60068-2-6.

#### Rated short-time withstand current

Our screw terminals are able to withstand a rated short-time current corresponding to a current density of 120 A/mm<sup>2</sup> specific to the nominal cross-section for a duration of one second.

#### Colored terminal blocks

With colored wiring according to EN 60204-1, the connecting level can also be included in the colored markings:

- Red for control circuits with AC current
- Blue for control circuits with DC current or neutral conductor
- Orange for interlock circuits with AC or DC current which are fed from outside and are live when the main switch is turned off
- Green-yellow through-type terminals for protective conductors (without connection to the support rail).

#### Design

The terminal blocks are insulated at both ends, with the exception of two-tier, flat and bolt-type terminals, which are insulated on one side only.

The insulating material for terminal sizes up to 70 mm<sup>2</sup> is made of thermoplast, polyamide 6.6.

The materials used are environment-friendly: For example, they are cadmium-free and contain no halogens or silicone.

The plastics used are flame-retardant and self-extinguishing according to EN 60695-2-2, VDE 0471, Part 2-2 and UL 94 V-2.

#### Clamping methods

The terminals are designed so that when the terminal screws are tightened, any tensile stress which occurs causes elastic deformation of the terminal bodies. This compensates for any creepage of the clamping conductor. Deformation of the thread part prevents loosening of the clamping screw, even in the event of heavy mechanical and thermal strain (e. g. vibration stress of 10 g or thermal cycles).

The following clamping methods are used: terminal body with pressure plate for terminal sizes 16, 35 and 70 mm<sup>2</sup>. Strain-relief clamps for terminal sizes 2.5, 4 and 6 mm<sup>2</sup>. Screw with connection disk for fuse terminals and component terminals.

#### Terminal size

The terminal size corresponds to the nominal cross-section. According to EN 60947-7-1, a finely stranded copper conductor of nominal cross-section can be connected to any clamping point with or without end sleeve.

#### Mounting

The terminals are snapped onto 35 mm support rails according to IEC 60715 TH35 and secured against movement using end retainers.

A lateral mounting tolerance of 0.2 mm must be maintained between the terminals.

#### Conductor connection

Except for flat and bolt-type versions, all terminal bodies are designed so that solid, stranded and finely stranded conductors with or without end sleeves (according to DIN 46228) can be securely clamped (please observe cross-section).

Damage to the clamped conductors is prevented by pressure plates or strain-relief clamps. For the conductor cross-sections when 1 or 2 conductors are connected, see technical specifications.

# 8WA1 Screw Terminals

## General data on 8WA

### Connection of aluminum conductors

Siemens screw terminals are suitable for connecting aluminum conductors provided there is compliance with the normal processing guidelines, i.e. the brushing and greasing of the conductors before connection.

After a few days, the connection should be tightened again for safety reasons.

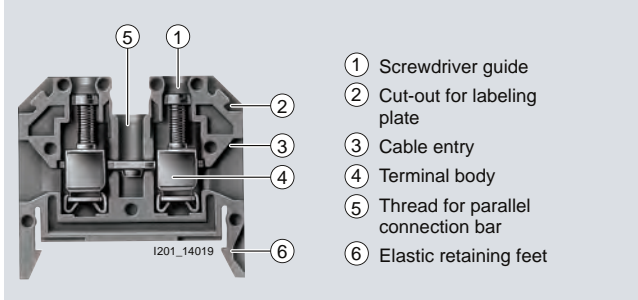

8WA1 through-type terminal with screw terminal at both ends, sectional view

### PE and PEN terminals

In switchgear and controlgear systems the support rails for the terminal blocks are frequently used as protective ground bus-bars. The PE terminals establish the connection to the support rail.

The fact that there is no separate PE busbar means the PE terminals, the insulated main conductor terminals and N-conductor isolating terminals can be arranged according to user requirements. This makes the individual circuits clearly manageable.

The bare 8WA1 010-1PH01 PE terminals are primarily used for connecting the shields of shielded cables. They are normally mounted on a standard mounting rail, which is supported by an 8WA1 857 insulation carrier and which is equipped with only one PE terminal for connection to the PE conductor.

### Accessories

#### Parallel connection bars

The connection bars are screwed into the terminals from above and allow parallel connection of up to 10 terminals up to terminal size 35 mm<sup>2</sup>. The 10-pole connection bars can be shortened as required. On 70 mm<sup>2</sup> terminals the connection bars are two-pole.

#### Barriers

Barriers are yellow in color and project beyond the contours of the terminals. They serve the visual separation of groups of terminals, the electrical isolation of adjacent connection bars and the improvement of the rated insulation voltage for soldered and plug-in connections.

#### Insulation plates

8WA1 825 and 8WA1 822-7TK00 insulation plates can be used with different terminals for providing electrical insulation between connection bars.

#### Test sockets and plugs

The 8WA1 854 test sockets for Ø 2.3 test plugs and reduction plugs with a Ø 4 mm hole can be screwed into some terminals in place of the connection bars.

#### Disconnecting links

The 8WA1 865 disconnecting links provide a detachable connection between two adjacent terminals sizes 2.5 to 6 mm<sup>2</sup>.

#### Covers with lightning symbol

The purpose of these covers is to identify the power input terminals. At the same time, they provide additional touch protection.

#### End retainers and end labeling plates

End retainers are available in thermoplastic or galvanized and chromated steel. The end labeling plate can be fitted in an 8WA1 808 end retainer or, in any of three positions, in an 8WA1 805 end retainer.

### Technical specifications

#### Continuous load at increased ambient temperatures

The 8WA1 terminal blocks can withstand an uninterrupted current at ambient temperatures of up to +55 °C. At higher ambient temperatures, a current reduction according to the following formula is required:

$$I_{th2} = I_{th2} \cdot k$$

$I_{th2}$  = Uninterrupted current according to selection tables, relative to the nominal cross-section  
 $I_{th2}$  = Uninterrupted current at increased ambient temperature  
 $k$  = Derating factor according to table

Ambient temperature	Derating factor $k$
60 °C	0.94
65 °C	0.88
70 °C	0.82
75 °C	0.75
80 °C	0.67
85 °C	0.58
90 °C	0.47
95 °C	0.33

The highest permissible clamping point overtemperature of 45 K specified in IEC 60947-1 is not exceeded at an ambient temperature of up to 100 °C.

#### Clamping points

Terminal size	Type <sup>1)</sup>	Thread diameter of terminal screws	Screwdriver blades acc. to DIN 5264 Form B	Tightening torque = test torque acc. to DIN VDE 0609 and DIN VDE 0611	Tensile forces acc. to IEC 60947-1 at max. conductor connection	Stripped length
				Nm		
1.5	8WA1 011- .SF. . , 8WA1 011-1EE00	M3.5	0.8 × 4	0.8	40	10
2.5	8WA1 . . 1, 8WA1 011-1BF11, 8WA1 011-1EF. . . 8WA1 011- . . F. . .	M2.5 and M3	0.5 × 3	0.5	50	11
		M2.5	0.8 × 4	0.5	50	11
4	8WA1 011- . . G. . . 8WA2 867	M3 M3.5	0.8 × 4	0.5 0.8 ... 1	60	11
6	8WA1 . . 2, 8WA1 011- . . H. . .	M3.5	0.8 × 4	0.8	80	11
16	8WA1 . . 4, 8WA1 011- . . K. . .	M4	0.8 × 4	1.2	100	13
25	8WA2 868	M5	1.2 × 6.5	2	135	
35	8WA1 . . 5, 8WA1 011- . . M. . . 8WA2 870	M6	1.2 × 6.5	2.5	190	17
				2.5 ... 3		
50	8WH1 000-0AN00, 8WH1 000-0AN01, 8WH1 000-0CN07 8WH1 070-0AN00	M6	1.2 × 8	6 ... 8	--	24
		M6	--	3 ... 7	--	6 ... 25
70	8WA1 . . 6	M8	4 hexagon socket-head	6	285	25
95	8WA1 010-1PQ00 8WH1 000-0AQ00, 8WH1 000-0AQ01 8WH1 000-0CQ07 8WH1 070-0AQ00 8WH1 060-0AQ00	M8	6 hexagon socket-head	15 ... 20	--	30
		M8	6 hexagon socket-head	15 ... 20	--	33
		M8	6 hexagon socket-head	15 ... 20	--	30
		M8	--	6 ... 15	--	16 ... 25
		M8	--	25 ... 30	--	29
150	8WH1 000-0AS0. 8WH1 070-0AS00 8WH1 060-0AS00	M10	8 hexagon socket-head	25 ... 30	--	40
		M10	--	10 ... 18	--	10 ... 18
		M10	--	25 ... 30	--	34
240	8WH1 000-0AU0. 8WH1 060-0AU00	M10	10 hexagon socket-head	30 ... 35	--	40
		M10	--	30 ... 35	--	34

<sup>1)</sup> Tightening torque also applicable for accessories (socket, connection bars, etc.).

#### Standard mounting rails as PEN rails

Only use Cu busbars.

They must have the same current carrying capacity as protective conductor busbars.

PEN busbars must carry only terminals and no devices.

#### Standard mounting rails as protective conductor busbars

Protective conductors with a larger cross-section than the protective conductor busbar, and with the same conductivity, can be connected to standard mounting rails that are also protective conductor busbars and carry current only under fault conditions.

Standard mounting rail acc. to EN 50022-35 and IEC 60715 TH35	Material	Type	Max. permissible cross-section of connected protective conductor
			mm <sup>2</sup>
35 × 7.5	Steel	5ST1 141	16
	Steel, perforated	5ST1 145	16
Similar to 35 × 15	Steel	5ST1 142	35
	Steel	--	50
	Copper	8WA7 551	150 <sup>1)</sup>

<sup>1)</sup> With 8WA1 010-1PQ00 terminal connection of up to 95 mm<sup>2</sup> finely stranded or 120 mm<sup>2</sup> stranded.

# 8WA1 Screw Terminals

## General data on 8WA

### Rated impulse withstand voltage of terminal blocks

Values dependent on the mains rated voltage  
 ≤ rated insulation voltage of terminal block; excerpt from  
 EN 60947-1, table H.1.

Terminal blocks are tested acc. to overvoltage category III.

Rated mains voltage (≤ rated insulating voltage of the device) RMS value V AC	Maximum rated operating voltage to ground RMS value V AC or V DC	Preferred values for rated impulse withstand voltage as 1.2/50 μs pulse Overvoltage category			
		I kV	II kV	III kV	IV kV
--	50	330	500	800	1500
66/115	100	500	800	1500	2500
120/208 127/220	150	800	1500	2500	4000
230/400 277/480	300	1500	2500	4000	6000
400/690	600	2500	4000	6000	8000
1000	1000	4000	6000	8000	12000

### Connection

Terminal size mm <sup>2</sup>	Type	Smallest conductor cross-section					Largest conductor cross-section				
		Solid mm <sup>2</sup>	Stranded mm <sup>2</sup>	Finely stranded mm <sup>2</sup>	Finely stranded with end sleeve <sup>1)</sup> mm <sup>2</sup> Size		Solid mm <sup>2</sup>	Stranded mm <sup>2</sup>	Finely stranded mm <sup>2</sup>	Finely stranded with end sleeve <sup>1)</sup> mm <sup>2</sup> Size	
<b>Single-conductor connection</b>											
1.5	8WA1 011-SF... 8WA1 011-1EE00	1	--	--	0.75	0.75 ... 10	2.5	--	--	1.5	1.5 ... 10
2.5	8WA1 211, 8WA1 011-. .F. .	0.25 <sup>2)</sup>	0.5	0.5	0.5	0.5 ... 10	4	2.5	2.5	2.5	2.5 ... 12 <sup>4)</sup>
	8WA1 011-3JF . .	0.25 <sup>2)</sup>	0.5	0.5	0.5	0.5 ... 10	4	2.5	2.5	2.5	2.5 ... 7
	8WA1 501, 8WA1 511, 8WA1 011-1EF. .	0.25 <sup>2)</sup>	0.5	0.5	0.5	0.5 ... 10	4	2.5	2.5	2.5	1.5 ... 10
4	8WA9 200	0.5	1.5	1.5	0.75	0.75 ... 10	6	4	4	4	4
	8WA2 86. feeder terminal	1	1.5	1.5	0.75	0.75 ... 10	6	4	4	4	4 ... 12 <sup>4)</sup>
	8WA1 011-. .G..	0.5	1.5	0.5	0.75	0.75 ... 10	6	4	4	4	4 ... 12 <sup>4)</sup>
6	8WA1 011-1.H..	0.75	1.5	1.5	0.5	0.5 ... 10	10	6	6	6	6 ... 12
	8WA1 010-1PH01	0.5	1.5	1.5	0.5	0.5 ... 10	10	6	6	6	6 ... 15
16	8WA1 204, 8WA1 304, 8WA1 011-1BK11	1.5	2.5	2.5	1	1 ... 10 <sup>3)</sup>	16	25	16	16	16 ... 12
	8WA1 604, 8WA1 011-1NK02	1.5	2.5	4	1.5	1 ... 10 <sup>3)</sup>	16	25	16	16	16 ... 12
	8WA1 011-1PK00	1.5	2.5	4	1.5	1.5 ... 7 <sup>6)</sup>	16	25	16	16	16 ... 15
	8WA2 86. feeder terminal	1.5	2.5	4	2.5	2.5 ... 12	16	16	10	10	10 ... 12
25	8WH1 060-0AL00	--	--	4	4	--	--	--	25	25	--
35	8WA1 205, 8WA1 305, 8WA1 011-1BM11	4	10	6	6	6 ... 15	16 <sup>5)</sup>	50	35	35	35 ... 18 <sup>7)</sup>
	8WA1 011-1PM00	4	10	10	6	6 ... 15	16 <sup>5)</sup>	50	35	25	25 ... 15
	8JH4 114 feeder terminal	6	10	16	6	6 ... 15	16	35	25	25	25 ... 15
	8WA2 870	6	10	16	6	6 ... 15	16	35	25	25	25 ... 15
50	8WH1 000-0AN00	--	--	10	10	--	--	--	50	50	--
	8WH1 000-0AN01	--	--	10	10	--	--	--	50	50	--
	8WH1 000-0CN07	--	--	25	25	--	--	--	50	50	--
	8WH1 070-0AN00	--	--	6 <sup>1)</sup>	--	--	--	--	--	35 <sup>1)</sup>	--
	8WH1 060-0AN00	--	--	25	25	--	--	--	50	50	--
70	8WA1 206	10	16	16	16	16 ... 12 <sup>6)</sup>	95	95	95	--	--
95	8WA1 010-1PQ00	--	50	50	--	--	--	95	95	--	--
	8WH1 000-0AQ00	--	--	35	35	--	--	--	95	95	--
	8WH1 000-0AQ01	--	--	35	35	--	--	--	95	95	--
	8WH1 000-0CQ07	--	--	35	35	--	--	--	35	95	--
	8WH1 070-0AQ00	--	--	--	16 <sup>1)</sup>	--	--	--	--	35 <sup>1)</sup>	--
	8WH1 060-0AQ00	--	--	35	35	--	--	--	95	95	--
150	8WH1 000-0AS00, 8WH1 000-0AS01	--	--	50	50	--	--	--	150	150	--
	8WH1 060-0AS00	--	--	50	50	--	--	--	150	150	--
	8WA1 011-1DU..	--	--	--	--	--	--	240	240	--	--
240	8WH1 000-0AU00, 8WH1 000-0AU01	--	--	70	70	--	--	--	185	185	--
	8WH1 060-0AU00	--	--	--	--	--	--	--	--	--	--

<sup>1)</sup> End sleeves acc. to DIN 46228 Sheet 1 without insulation. Size corresponds to sleeve nominal size.

<sup>2)</sup> 0.12/0.25 mm<sup>2</sup> corresponds to ∅ 0.4/0.6 mm.

<sup>3)</sup> For 0.75 mm<sup>2</sup> conductors, use end sleeves 1-10 and press on with insert E1 or PZ 1.5.

<sup>4)</sup> At voltages > 500 V, shorten end sleeves with inserted conductor to 10 mm before pressing on.

<sup>5)</sup> Tested up to 16 mm<sup>2</sup>.

<sup>6)</sup> Fit and press on two end sleeves one after the other (up to stop).

<sup>7)</sup> Voltage reduction to 630 V required.

Terminal size mm <sup>2</sup>	Type	Smallest conductor cross-section					Largest conductor cross-section				
		Solid mm <sup>2</sup>	Stranded mm <sup>2</sup>	Finely stranded mm <sup>2</sup>	Finely stranded with end sleeve <sup>1)</sup> mm <sup>2</sup> Size		Solid mm <sup>2</sup>	Stranded mm <sup>2</sup>	Finely stranded mm <sup>2</sup>	Finely stranded with end sleeve <sup>1)</sup> mm <sup>2</sup> Size	
<b>Two-wire connection</b> , 2 conductors each of same cross-section; with end sleeves the two rectangular sleeves must be inserted in the same position. 											
1.5	8WA1 011-. SF . ., -1EE00	2 × 1	--	--	2 × 0.75	1 ... 10 <sup>3)</sup>	2 × 2.5	--	--	2 × 1.5	1.5 ... 10
2.5	8WA1 211, 8WA1 011-. F. .	2 × 0.12 <sup>2)</sup>	2 × 0.5	2 × 0.5	2 × 0.5 <sup>9)</sup>	0.75 ... 6	2 × 0.75	2 × 0.5	2 × 0.5	2 × 1.5 <sup>9)</sup>	1.5 ... 10
	8WA1 501, 8WA1 511, 8WA1 011-1EF .	2 × 0.12 <sup>2)</sup>	2 × 0.5	2 × 0.25	--	--	2 × 0.75	2 × 0.5	2 × 0.75	--	--
4	8WA1 011-. G. ., -1DG11	2 × 0.5	2 × 1	2 × 1	2 × 0.5	0.5 × 10	2 × 1.5	2 × 1.5	2 × 1.5	2 × 1.5	1.5 ... 10
	8WA1 011-2DG11	2 × 0.5	2 × 1	2 × 1	2 × 0.5	0.5 × 10	2 × 1	2 × 1.5	2 × 1.5	2 × 1	1 ... 10
	8WA1 011-6DG11, top	2 × 0.5	2 × 1	2 × 1	2 × 0.5	0.5 × 10	2 × 1.5	2 × 1.5	2 × 1.5	2 × 1	1 ... 10
	8WA1 011-6DG11, bottom	2 × 0.5	2 × 1	2 × 1	2 × 0.5	0.5 × 10	2 × 1	2 × 1.5	2 × 1.5	2 × 1	1 ... 10
	8WA1 011-1PG00	2 × 0.5	2 × 1	2 × 1	2 × 0.5	0.5 × 10	2 × 1	2 × 1.5	2 × 1.5	2 × 1	1 ... 10
8WA1 011-1PG11, -1NG01	2 × 0.5	2 × 1	2 × 1	2 × 0.5	0.5 × 10	2 × 1.5	2 × 1.5	2 × 1.5	2 × 1	1 ... 10	
6	8WA1 011-1. H. ., -3DH21	2 × 0.5	2 × 0.75	2 × 0.75	2 × 0.5	0.5 × 10	2 × 1.5	2 × 1.5	2 × 1.5	2 × 1.5	1.5 ... 10
	8WA1 010-1PH01	2 × 0.5	2 × 0.75	2 × 0.75	2 × 0.5	0.5 × 10	2 × 1.5	2 × 1.5	2 × 1.5	2 × 0.75	1 ... 10
16	8WA1 204, 8WA1 304, 8WA1 604, 8WA1 011-1BK11	2 × 1	2 × 2.5	2 × 2.5	2 × 1	1 ... 10	2 × 4	2 × 4	2 × 4	2 × 4	4 ... 12
	8WA1 734	2 × 2.5	--	--	2 × 1.5	1.5 ... 7 <sup>6)</sup>	2 × 4	2 × 4	2 × 4	2 × 4	4 ... 12
35	8WA1 205, 8WA1 305, 8WA1 011-1BM11, 8WA1 735	2 × 4	2 × 10	2 × 6	2 × 6	6 ... 15	2 × 10	2 × 10	2 × 10	2 × 10	10 ... 15
50	8WH1 000-0AN00, 8WH1 000-0AN01, 8WH1 000-0CN07	2 × 10	2 × 10	2 × 10	2 × 10	--	2 × 35	2 × 35	2 × 35	2 × 35	--
70	8WA1 206	2 × 10	2 × 10	2 × 10	2 × 10	10 ... 12 <sup>6)</sup>	2 × 16	2 × 16	2 × 16	2 × 16	16 ... 12 <sup>7)</sup>
95	8WH1 000-0AQ00, 8WH1 000-0AQ01, 8WH1 000-0CQ07	2 × 25	2 × 25	2 × 25	2 × 25	--	2 × 35	2 × 35	2 × 35	2 × 35	--
150	8WH1 000-0AS00, 8WH1 000-0AS01	2 × 25	2 × 25	2 × 25	2 × 25	--	2 × 50	2 × 50	2 × 50	2 × 50	--
240	8WH1 000-0AU00, 8WH1 000-0AU01	2 × 35	2 × 35	2 × 35	2 × 35	--	2 × 95	2 × 95	2 × 95	2 × 95	--

<sup>1)</sup> End sleeves acc. to DIN 46228 Sheet 1 without insulation. Size corresponds to sleeve nominal size.

<sup>2)</sup> 0.12/0.25 mm<sup>2</sup> corresponds to  $\varnothing$  0.4/0.6 mm.

<sup>3)</sup> For 0.75 mm<sup>2</sup> conductors, use end sleeves 1-10 and press on with insert E1 or PZ 1.5.

<sup>4)</sup> At voltages > 500 V, shorten end sleeves with inserted conductor to 10 mm before pressing on.

<sup>5)</sup> Tested up to 16 mm<sup>2</sup>.

<sup>6)</sup> Fit and press on two end sleeves one after the other (up to stop).

<sup>7)</sup> Voltage reduction to 630 V required.

### Conductor cross-sections to AWG "American Wire Gauge"

AWG No.	Wire diameter mm	Cross-section mm <sup>2</sup>	AWG No.	Wire diameter mm	Cross-section mm <sup>2</sup>	AWG No.	Wire diameter mm	Cross-section mm <sup>2</sup>
30	0.254	0.051	18	1.024	0.82	6	4.115	13.30
29	0.287	0.065	17	1.151	1.04	5	4.620	16.77
28	0.320	0.081	16	1.290	1.31	4	5.189	21.15
27	0.363	0.102	15	1.450	1.65	3	5.827	26.66
26	0.404	0.128	14	1.628	2.08	2	6.543	33.62
25	0.455	0.163	13	1.829	2.63	1	7.348	42.41
24	0.511	0.205	12	2.052	3.31	1/0	8.252	53.52
23	0.574	0.259	11	2.304	4.17	2/0	9.266	67.43
22	0.643	0.33	10	2.588	5.26	3/0	10.404	85.01
21	0.724	0.41	9	2.906	6.63	4/0	11.684	107.21
20	0.813	0.52	8	3.268	8.37	5/0	--	135.35
19	0.912	0.65	7	3.665	10.55	6/0	--	170.50

# 8WA1 Screw Terminals







## General data on 8WA

### Ⓢ and Ⓜ rating

Terminal size mm <sup>2</sup>	Type	CSA rating			UR rating		
		AWG	Rated current $I_n$ A	Rated voltage $U_e$ V	AWG	Rated current $I_n$ A	Rated voltage $U_e$ V
1.5	8WA1 011-1SF12	18-14	6.3	600	18-14	6.3	600
	8WA1 011-1SF24, -2SF24, -4SF24	14	1	--	14-12	1	AC240/DC60
	8WA1 011-1SF25, -2SF25, -4SF25	14	2	--	14-12	2	AC240/DC60
	8WA1 011-1SF26, -2SF26, -4SF26	14	4	--	14-12	4	AC240/DC60
	8WA1 011-1SF27, -2SF27, -4SF27	14	6	--	14-12	6	AC240/DC60
8WA1 011-1SF28, -2SF28, -4SF28	14	10	--	14-12	10	AC240/DC60	
2.5	8WA1 011-1BF21, -1BF22, -1BF23, -1PF11	18-12	25	600	22-12	26	600
	8WA1 011-1DF11, -3DF21, -ODF21, -ODF22	18-12	25	600	22-12	26	600
	8WA1 011-1NF01, -1NF02	22-12	26	600	22-12	26	600
	8WA1 011-3JF..	--	--	--	22-12	26	300
	8WA1 011-1PF00, 8WA1 011-1PF01	22-12	--	--	22-12	--	--
	8WA1 501	22-12	10	300 D	22-12	10	300
4	8WA1 011-1PG00, 8WA1 011-1PG01	18-10	--	--	18-10	--	--
	8WA1 011-1BG11, -1BG21, -1BG22	18-10	40	600	18-10	35	600
	8WA1 011-1DG11, -3DG21, -ODG21, -ODG22	18-10	40	600	18-10	35	600
	8WA1 011-1NG31, -1NG32	18-10	40	600	18-10	35	600
	8WA1 011-1PG11	18-10	40	600	--	--	--
	8WA1 011-2BG11, -2DG11	18-10	40	300	18-10	35	600
	8WA1 011-6BG11, -6DG11	18-10	40	300	18-10	35	600
	8WA1 011-6EG..	--	--	--	18-10	34	300
	8WA9 200	18-10	25	300	18-10	26	600
	6	8WA1 011-1PH00	--	--	--	14-8	--
8WA1 011-1BH23, -1PH11		16-10	35	600	14-8	44	600
8WA1 011-1DH11, -3DH21		16-8	35	600	14-8	44	600
8WA1 011-1NH01, -1NH02		14-8	44	600	14-8	44	600
8WA1 011-1MH10, -1MH11, -1MH15		16-10	35/40	600/300 C/D	14-8	44	600/300
8WA1 232		--	--	--	-- <sup>1)</sup>	24	600
16	8WA1 011-1BK11	14-6	70	600	12-4	79	600
	8WA1 011-1NK02	--	--	--	12-4	73	300
	8WA1 011-1PK00	12-4	--	--	12-4	--	--
	8WA1 012-1DK10	--	--	--	--	79	600
	8WA1 204, 8WA1 304	14-6	70	600	12-4	79	600
8WA1 604	--	--	--	12-4	73	300	
25	8WH1 060-0AL00	6-4	100	600	6-4	85	600
35	8WA1 011-1BM11	12-2	100	600	10-1	120	600
	8WA1 011-1PM00	10-1	--	--	10-1	--	--
	8WA1 205, 8WA1 305	12-2	100	600	10-1	120	600
50	8WH1 000-0AN00, 8WH1 000-0AN01	6-0	125	600	6-0	150	600
	8WH1 000-0CN07	--	--	--	6-1	--	--
	8WH1 060-0AN00	6-0	125	600	6-0	150	600
70	8WA1 012-1DP14	2/0-1	170	600	6-3/0	--	600
	8WA1 206	8-1/0	150	600	8-3/0	220	600
95	8WH1 000-0AQ00, 8WH1 000-0AQ01	1-000	220	600	2-000	230	600
	8WH1 000-0CQ07	2-4	--	--	2-4	--	--
	8WH1 060-0AQ00	2-000	200	600	2-000	230	600
150	8WH1 000-0AS0, 8WH1 000-0AS01	2 - 300 kcmil	275	600	2 - 300 kcmil	285	600
	8WH1 060-0AS00	2 - 300 kcmil	275	600	2 - 300 kcmil	285	600
240	8WH1 000-0AU00, 8WH1 000-0AU01	0 - 500 kcmil	400	600	0 - 500 kcmil	380	600
	8WH1 000-0AU00	0 - 500 kcmil	400	600	0 - 500 kcmil	380	600

1) Plug-in connection

### Selection and ordering data

Version	Order No.	MOQ*
<b>General details</b> <ul style="list-style-type: none"> <li>• Thermoplastic insulating body</li> <li>• Screw terminal at both ends</li> <li>• Enclosed at both ends</li> </ul>		
Note	Section	Page
For labeling accessories, see ...	Accessories	8/2
<b>Terminal size 2.5 mm<sup>2</sup></b>		
<b>Through-type terminals, terminal size 2.5 mm<sup>2</sup></b> <ul style="list-style-type: none"> <li>• Rated uninterrupted current 24 A</li> <li>• Rated insulation voltage 800 V</li> <li>• Mounting width 6 mm</li> <li>• Terminal height 26 mm</li> <li>• Terminal length 41 mm</li> <li>•  AWG 22-12</li> <li>•  AWG 18-12</li> </ul>		
<b>Versions</b> <ul style="list-style-type: none"> <li>• Single terminals                             <ul style="list-style-type: none"> <li>- Beige</li> <li>- Blue</li> <li>- Red</li> <li>- Orange</li> <li>- Yellow</li> <li>- Black</li> <li>- Green</li> </ul> </li> <li>• Terminal blocks                             <ul style="list-style-type: none"> <li>- Beige, 3-pole, width 18 mm</li> <li>- Beige, 10-pole, width 61 mm, with designation 1 ... 10</li> <li>- Beige, 10-pole, width 61 mm, without inscription</li> </ul> </li> </ul>		
<b>Accessories</b>		
<ul style="list-style-type: none"> <li>• Covers                             <ul style="list-style-type: none"> <li>- With lightning symbol, for terminal size 1.5 to 2.5 mm<sup>2</sup></li> <li>- White, facility for inscription, for terminal size 1.5 to 2.5 mm<sup>2</sup></li> <li>- For connection bars                                     <ul style="list-style-type: none"> <li>◦ Transparent, for terminal size 2.5 to 6 mm<sup>2</sup></li> <li>◦ White, facility for inscription, for terminal size 2.5 to 6 mm<sup>2</sup></li> </ul> </li> </ul> </li> <li>• Jumpers, for terminal size 2.5 mm<sup>2</sup></li> <li>• Test sockets</li> <li>• Disconnecting links</li> </ul>		
<b>Note</b> <p>Between terminals with terminal sizes 2.5 and 6 mm<sup>2</sup>, two 8WH1 820 barriers are required.</p>		
<ul style="list-style-type: none"> <li>• Insulation plates, for terminal size 2.5 to 6 mm<sup>2</sup></li> <li>• Connection bars, for terminal size 2.5 mm<sup>2</sup> <ul style="list-style-type: none"> <li>- For two terminals</li> <li>- For three terminals</li> <li>- For four terminals</li> <li>- For ten terminals</li> </ul> </li> <li>• Barriers, for terminal size 1.5 to 4 mm<sup>2</sup></li> </ul>		
<b>PE through-type terminals, terminal size 2.5 mm<sup>2</sup></b> <ul style="list-style-type: none"> <li>• Green/yellow</li> <li>• Mounting width 6 mm</li> <li>• Terminal height 26 mm</li> <li>• Terminal length 51 mm</li> </ul>		
<b>Versions</b> <ul style="list-style-type: none"> <li>• One screw terminal</li> <li>• Two screw terminals</li> </ul>		
<b>Accessories</b>		
<ul style="list-style-type: none"> <li>• Barriers, for terminal size 1.5 to 4 mm<sup>2</sup></li> </ul>		
 <p>8WA1 011-1DF11</p>		
 <p>8WA1 011-3DF21</p>		
 <p>8WA1 011-0DF21</p>		
 <p>8WA1 011-1PF01</p>		
<b>8WA1 011-1DF11</b>		100 units
<b>8WA1 011-1BF23</b>		50 units
<b>8WA1 011-1BF21</b>		50 units
<b>8WA1 011-1BF22</b>		50 units
<b>8WA1 011-1BF26</b>		50 units
<b>8WA1 011-1BF24</b>		50 units
<b>8WA1 011-1BF25</b>		50 units
<b>8WA1 011-3DF21</b>		10 units
<b>8WA1 011-0DF22</b>		20 units
<b>8WA1 011-0DF21</b>		20 units
<b>8WA1 810</b>		50 units
<b>8WA1 860</b>		50 units
<b>8WA1 822-7AX01</b>		10 units
<b>8WA1 822-7AX03</b>		10 units
<b>8WA1 822-7VF01</b>		50 units
<b>8WA1 854</b>		100 units
<b>8WA1 865</b>		50 units
<b>8WA1 825</b>		50 units
<b>8WA1 895</b>		50 units
<b>8WA1 896</b>		50 units
<b>8WA1 897</b>		20 units
<b>8WA1 898</b>		10/200 units
<b>8WA1 820</b>		50 units
<b>8WA1 011-1PF01</b>		50 units
<b>8WA1 011-1PF00</b>		50 units
<b>8WA1 820</b>		50 units

# 8WA1 Screw Terminals

## 8WA through-type terminals

Version	Order No.	MOQ*
---------	-----------	------

### Terminal size 4 mm<sup>2</sup>



8WA1 011-1DG11



8WA1 011-0DG21

#### Through-type terminals, terminal size 4 mm<sup>2</sup>

- Rated uninterrupted current 32 A
- Rated insulation voltage 800 V
- Mounting width 6.5 mm
- Terminal height 30 mm
- Terminal length 41 mm
- **UL** AWG 18-10
- **CE** AWG 18-10

#### Versions

- Single terminals
  - Beige
  - Blue
  - Red
  - Orange
  - Black
- Terminal blocks
  - Beige, 3-pole, width 19.5 mm
  - Beige, 10-pole, width 65.5 mm, labeled 1 ... 10
  - Beige, 10-pole, width 65.5 mm, without inscription

#### Accessories

	Section	Page
• <b>Covers</b>		
- With lightning symbol, for terminal size 4 and 6 mm <sup>2</sup>	Accessories	9/13
- White, facility for inscription, for terminal size 4 and 6 mm <sup>2</sup>	Accessories	9/13
- For connection bars		
◦ Transparent, for terminal size 2.5 to 6 mm <sup>2</sup>	Accessories	9/13
◦ White, facility for inscription, for terminal size 2.5 to 6 mm <sup>2</sup>	Accessories	9/13
• Jumpers, for terminal size 4 mm <sup>2</sup>	Accessories	9/13
• Terminal strips	Accessories	9/14
• Test sockets	Accessories	9/14
• Disconnecting links	Accessories	9/14

#### Note

Between terminals with terminal sizes 2.5 and 6 mm<sup>2</sup>, two 8WH1 820 barriers are required.

• Insulation plates, for terminal size 2.5 to 6 mm <sup>2</sup>	Accessories	9/14
• Connection bars, for terminal size 4 mm <sup>2</sup>		
- For two terminals	Accessories	9/14
- For three terminals	Accessories	9/14
- For four terminals	Accessories	9/14
- For ten terminals	Accessories	9/14
• Barriers, for terminal size 1.5 to 4 mm <sup>2</sup>	Accessories	9/14

#### PE through-type terminals, terminal size 4 mm<sup>2</sup>

- Green/yellow
- Mounting width 7.2 mm
- Terminal height 30 mm
- Terminal length 51 mm
- **UL** **CE**









#### Versions

- One screw terminal
- Two screw terminals

#### Accessories

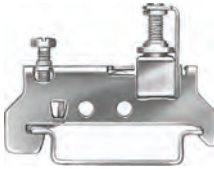
	Section	Page
Barriers, for terminal size 1.5 to 4 mm <sup>2</sup>	Accessories	9/14











<b>8WA1 011-1DG11</b>	100 units
<b>8WA1 011-1BG11</b>	50 units
<b>8WA1 011-1BG21</b>	50 units
<b>8WA1 011-1BG22</b>	50 units
<b>8WA1 011-1BG24</b>	50 units
<b>8WA1 011-3DG21</b>	10 units
<b>8WA1 011-0DG22</b>	20 units
<b>8WA1 011-0DG21</b>	20 units
<b>8WA1 811</b>	50 units
<b>8WA1 862</b>	50 units
<b>8WA1 822-7AX01</b>	10 units
<b>8WA1 822-7AX03</b>	10 units
<b>8WA1 822-7VG00</b>	50 units
<b>8WA1 741-2X</b>	5 units
<b>8WA1 854</b>	100 units
<b>8WA1 865</b>	50 units
<b>8WA1 825</b>	50 units
<b>8WA1 850</b>	50 units
<b>8WA1 851</b>	50 units
<b>8WA1 852</b>	20 units
<b>8WA1 853</b>	10 units
<b>8WA1 820</b>	50 units
<b>8WA1 011-1PG01</b>	50 units
<b>8WA1 011-1PG00</b>	50 units
<b>8WA1 820</b>	50 units





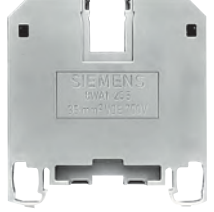





Version	Order No.	MOQ*																																
<b>Terminal size 6 mm<sup>2</sup></b>																																		
 <p>8WA1 011-1DH11</p>  <p>8WA1 011-3DH21</p>	<p><b>Through-type terminals, terminal size 6 mm<sup>2</sup></b></p> <ul style="list-style-type: none"> <li>• Rated uninterrupted current 41 A</li> <li>• Rated insulation voltage 800 V</li> <li>• Mounting width 8 mm</li> <li>• Terminal height 33 mm</li> <li>• Terminal length 41 mm</li> <li>•  AWG 14-8</li> <li>•  AWG 16-8</li> </ul> <p>Versions</p> <ul style="list-style-type: none"> <li>• Single terminals                             <ul style="list-style-type: none"> <li>- Beige</li> <li>- Blue</li> <li>- Black</li> </ul> </li> <li>• Terminal blocks                             <ul style="list-style-type: none"> <li>- Beige, 3-pole, width 24.5 mm</li> </ul> </li> </ul> <p>Accessories</p> <table border="1"> <thead> <tr> <th>Section</th> <th>Page</th> </tr> </thead> <tbody> <tr> <td>• Covers</td> <td></td> </tr> <tr> <td>- With lightning symbol, for terminal size 4 to 6 mm<sup>2</sup></td> <td>Accessories 9/13</td> </tr> <tr> <td>- White, facility for inscription, for terminal size 4 and 6 mm<sup>2</sup></td> <td>Accessories 9/13</td> </tr> <tr> <td>- For connection bars, transparent, for terminal size 2.5 to 6 mm<sup>2</sup></td> <td>Accessories 9/13</td> </tr> <tr> <td>• Jumpers, for terminal size 6 mm<sup>2</sup></td> <td>Accessories 9/13</td> </tr> <tr> <td>• Test sockets</td> <td>Accessories 9/14</td> </tr> <tr> <td>• Disconnecting links</td> <td>Accessories 9/14</td> </tr> </tbody> </table> <p>Note</p> <p>Between terminals with terminal sizes 2.5 and 6 mm<sup>2</sup>, two 8WH1 820 barriers are required.</p> <table border="1"> <thead> <tr> <th>Section</th> <th>Page</th> </tr> </thead> <tbody> <tr> <td>• Insulation plates, for terminal size 2.5 to 6 mm<sup>2</sup></td> <td>Accessories 9/14</td> </tr> <tr> <td>• Connection bars, for terminal size 6 mm<sup>2</sup></td> <td></td> </tr> <tr> <td>- For two terminals</td> <td>Accessories 9/14</td> </tr> <tr> <td>- For three terminals</td> <td>Accessories 9/14</td> </tr> <tr> <td>- For four terminals</td> <td>Accessories 9/14</td> </tr> <tr> <td>- For ten terminals</td> <td>Accessories 9/14</td> </tr> <tr> <td>• Barriers, for terminal size 6 and 16 mm<sup>2</sup></td> <td>Accessories 9/14</td> </tr> </tbody> </table>	Section	Page	• Covers		- With lightning symbol, for terminal size 4 to 6 mm <sup>2</sup>	Accessories 9/13	- White, facility for inscription, for terminal size 4 and 6 mm <sup>2</sup>	Accessories 9/13	- For connection bars, transparent, for terminal size 2.5 to 6 mm <sup>2</sup>	Accessories 9/13	• Jumpers, for terminal size 6 mm <sup>2</sup>	Accessories 9/13	• Test sockets	Accessories 9/14	• Disconnecting links	Accessories 9/14	Section	Page	• Insulation plates, for terminal size 2.5 to 6 mm <sup>2</sup>	Accessories 9/14	• Connection bars, for terminal size 6 mm <sup>2</sup>		- For two terminals	Accessories 9/14	- For three terminals	Accessories 9/14	- For four terminals	Accessories 9/14	- For ten terminals	Accessories 9/14	• Barriers, for terminal size 6 and 16 mm <sup>2</sup>	Accessories 9/14	<p><b>8WA1 011-1DH11</b> 50 units</p> <p><b>8WA1 011-1BH23</b> 50 units</p> <p><b>8WA1 011-1BH24</b> 50 units</p> <p><b>8WA1 011-3DH21</b> 20 units</p> <p><b>8WA1 811</b> 50 units</p> <p><b>8WA1 862</b> 50 units</p> <p><b>8WA1 822-7AX01</b> 10 units</p> <p><b>8WA1 822-7VH00</b> 50 units</p> <p><b>8WA1 854</b> 100 units</p> <p><b>8WA1 865</b> 50 units</p> <p><b>8WA1 825</b> 50 units</p> <p><b>8WA1 885</b> 50 units</p> <p><b>8WA1 886</b> 50 units</p> <p><b>8WA1 887</b> 20 units</p> <p><b>8WA1 888</b> 10 units</p> <p><b>8WA1 821</b> 50 units</p> <p><b>8WA1 010-1PH01</b> 50 units</p> <p><b>8WA1 011-1PH00</b> 50 units</p> <p><b>8WA1 821</b> 50 units</p>
Section	Page																																	
• Covers																																		
- With lightning symbol, for terminal size 4 to 6 mm <sup>2</sup>	Accessories 9/13																																	
- White, facility for inscription, for terminal size 4 and 6 mm <sup>2</sup>	Accessories 9/13																																	
- For connection bars, transparent, for terminal size 2.5 to 6 mm <sup>2</sup>	Accessories 9/13																																	
• Jumpers, for terminal size 6 mm <sup>2</sup>	Accessories 9/13																																	
• Test sockets	Accessories 9/14																																	
• Disconnecting links	Accessories 9/14																																	
Section	Page																																	
• Insulation plates, for terminal size 2.5 to 6 mm <sup>2</sup>	Accessories 9/14																																	
• Connection bars, for terminal size 6 mm <sup>2</sup>																																		
- For two terminals	Accessories 9/14																																	
- For three terminals	Accessories 9/14																																	
- For four terminals	Accessories 9/14																																	
- For ten terminals	Accessories 9/14																																	
• Barriers, for terminal size 6 and 16 mm <sup>2</sup>	Accessories 9/14																																	
 <p>8WA1 010-1PH01</p>	<p><b>PE through-type terminals, terminal size 6 mm<sup>2</sup>, one screw terminal</b></p> <ul style="list-style-type: none"> <li>• Bare</li> <li>• Mounting width 6 mm</li> <li>• Terminal height 25 mm</li> <li>• Terminal length 44 mm</li> <li>• Also for use as shield terminal</li> </ul> <p>Accessories</p> <table border="1"> <thead> <tr> <th>Section</th> <th>Page</th> </tr> </thead> <tbody> <tr> <td>Barriers, for terminal size 6 and 16 mm<sup>2</sup></td> <td>Accessories 9/14</td> </tr> </tbody> </table>	Section	Page	Barriers, for terminal size 6 and 16 mm <sup>2</sup>	Accessories 9/14																													
Section	Page																																	
Barriers, for terminal size 6 and 16 mm <sup>2</sup>	Accessories 9/14																																	
 <p>8WA1 011-1PH00</p>	<p><b>PE through-type terminals, terminal size 6 mm<sup>2</sup>, two screw terminals</b></p> <ul style="list-style-type: none"> <li>• Green/yellow</li> <li>• Mounting width 8 mm</li> <li>• Terminal height 33 mm</li> <li>• Terminal length 51 mm</li> <li>•  </li> </ul> <p>Accessories</p> <table border="1"> <thead> <tr> <th>Section</th> <th>Page</th> </tr> </thead> <tbody> <tr> <td>Barriers, for terminal size 6 and 16 mm<sup>2</sup></td> <td>Accessories 9/14</td> </tr> </tbody> </table>	Section	Page	Barriers, for terminal size 6 and 16 mm <sup>2</sup>	Accessories 9/14																													
Section	Page																																	
Barriers, for terminal size 6 and 16 mm <sup>2</sup>	Accessories 9/14																																	

\* You can order this quantity or a multiple thereof.

# 8WA1 Screw Terminals

## 8WA through-type terminals







Version	Order No.	MOQ*																								
<b>Terminal size 16 mm<sup>2</sup></b>																										
 <p>8WA1 204</p>  <p>8WA1 304</p>	<p><b>Through-type terminals, terminal size 16 mm<sup>2</sup></b></p> <ul style="list-style-type: none"> <li>• Rated uninterrupted current 76 A</li> <li>• Rated insulation voltage 800 V</li> <li>• Mounting width 10 mm</li> <li>• Terminal height 38 mm</li> <li>• Terminal length 41 mm</li> <li>•  AWG 12-4</li> <li>•  AWG 14-6</li> </ul> <p><b>Versions</b></p> <ul style="list-style-type: none"> <li>• Single terminals                             <ul style="list-style-type: none"> <li>- Beige</li> <li>- Blue</li> </ul> </li> <li>• Terminal blocks                             <ul style="list-style-type: none"> <li>- 3-pole, width 30 mm</li> </ul> </li> </ul> <p><b>Accessories</b></p> <table border="1"> <thead> <tr> <th>Section</th> <th>Page</th> </tr> </thead> <tbody> <tr> <td><b>Covers</b></td> <td></td> </tr> <tr> <td>- With lightning symbol, for terminal size 16 mm<sup>2</sup></td> <td>Accessories 9/13</td> </tr> <tr> <td>- White, facility for inscription, for terminal size 16 mm<sup>2</sup></td> <td>Accessories 9/13</td> </tr> <tr> <td>- For connection bars, transparent, for terminal size 16 and 35 mm<sup>2</sup></td> <td>Accessories 9/13</td> </tr> <tr> <td><b>Insulation plates, for terminal size 16 and 35 mm<sup>2</sup></b></td> <td>Accessories 9/14</td> </tr> <tr> <td><b>Connection bars, for terminal size 16 mm<sup>2</sup></b></td> <td></td> </tr> <tr> <td>- For two terminals</td> <td>Accessories 9/14</td> </tr> <tr> <td>- For three terminals</td> <td>Accessories 9/14</td> </tr> <tr> <td>- For four terminals</td> <td>Accessories 9/14</td> </tr> <tr> <td>- For ten terminals</td> <td>Accessories 9/14</td> </tr> <tr> <td><b>Barriers, for terminal size 6 and 16 mm<sup>2</sup></b></td> <td>Accessories 9/14</td> </tr> </tbody> </table>	Section	Page	<b>Covers</b>		- With lightning symbol, for terminal size 16 mm <sup>2</sup>	Accessories 9/13	- White, facility for inscription, for terminal size 16 mm <sup>2</sup>	Accessories 9/13	- For connection bars, transparent, for terminal size 16 and 35 mm <sup>2</sup>	Accessories 9/13	<b>Insulation plates, for terminal size 16 and 35 mm<sup>2</sup></b>	Accessories 9/14	<b>Connection bars, for terminal size 16 mm<sup>2</sup></b>		- For two terminals	Accessories 9/14	- For three terminals	Accessories 9/14	- For four terminals	Accessories 9/14	- For ten terminals	Accessories 9/14	<b>Barriers, for terminal size 6 and 16 mm<sup>2</sup></b>	Accessories 9/14	<p><b>8WA1 204</b> 20 units</p> <p><b>8WA1 011-1BK11</b> 10 units</p> <p><b>8WA1 304</b> 20 units</p> <hr/> <p><b>8WA1 812</b> 50 units</p> <p><b>8WA1 892</b> 50 units</p> <p><b>8WA1 822-7AX02</b> 10 units</p> <p><b>8WA1 822-7TK00</b> 50 units</p> <hr/> <p><b>8WA1 842</b> 20 units</p> <p><b>8WA1 845</b> 20 units</p> <p><b>8WA1 848</b> 10 units</p> <p><b>8WA1 802</b> 10 units</p> <p><b>8WA1 821</b> 50 units</p>
Section	Page																									
<b>Covers</b>																										
- With lightning symbol, for terminal size 16 mm <sup>2</sup>	Accessories 9/13																									
- White, facility for inscription, for terminal size 16 mm <sup>2</sup>	Accessories 9/13																									
- For connection bars, transparent, for terminal size 16 and 35 mm <sup>2</sup>	Accessories 9/13																									
<b>Insulation plates, for terminal size 16 and 35 mm<sup>2</sup></b>	Accessories 9/14																									
<b>Connection bars, for terminal size 16 mm<sup>2</sup></b>																										
- For two terminals	Accessories 9/14																									
- For three terminals	Accessories 9/14																									
- For four terminals	Accessories 9/14																									
- For ten terminals	Accessories 9/14																									
<b>Barriers, for terminal size 6 and 16 mm<sup>2</sup></b>	Accessories 9/14																									
 <p>8WA1 011-1PK00</p>	<p><b>PE through-type terminals and through-type PEN terminals, terminal size 16 mm<sup>2</sup></b></p> <ul style="list-style-type: none"> <li>• Green/yellow</li> <li>• for I = 76 A</li> <li>• Mounting width 12 mm</li> <li>• Terminal height 38 mm</li> <li>• Terminal length 53 mm</li> <li>• Two screw terminals</li> <li>•  </li> </ul> <p><b>Accessories</b></p> <table border="1"> <thead> <tr> <th>Section</th> <th>Page</th> </tr> </thead> <tbody> <tr> <td><b>Barriers, for terminal size 6 and 16 mm<sup>2</sup></b></td> <td>Accessories 9/14</td> </tr> </tbody> </table>	Section	Page	<b>Barriers, for terminal size 6 and 16 mm<sup>2</sup></b>	Accessories 9/14	<p><b>8WA1 011-1PK00</b> 25 units</p> <hr/> <p><b>8WA1 821</b> 50 units</p>																				
Section	Page																									
<b>Barriers, for terminal size 6 and 16 mm<sup>2</sup></b>	Accessories 9/14																									
<b>Terminal size 35 mm<sup>2</sup></b>																										
 <p>8WA1 205</p>  <p>8WA1 305</p>	<p><b>Through-type terminals, terminal size 35 mm<sup>2</sup></b></p> <ul style="list-style-type: none"> <li>• Rated uninterrupted current 125 A</li> <li>• Rated insulation voltage 800 V</li> <li>• Mounting width 16 mm</li> <li>• Terminal height 50 mm</li> <li>• Terminal length 53 mm</li> <li>•  AWG 10-1</li> <li>•  AWG 12-2</li> </ul> <p><b>Versions</b></p> <ul style="list-style-type: none"> <li>• Single terminals                             <ul style="list-style-type: none"> <li>- Beige</li> <li>- Blue</li> </ul> </li> <li>• Terminal blocks                             <ul style="list-style-type: none"> <li>- 3-pole, width 48 mm</li> </ul> </li> </ul> <p><b>Accessories</b></p> <table border="1"> <thead> <tr> <th>Section</th> <th>Page</th> </tr> </thead> <tbody> <tr> <td><b>Covers</b></td> <td></td> </tr> <tr> <td>- With lightning symbol, for terminal size 35 mm<sup>2</sup></td> <td>Accessories 9/13</td> </tr> <tr> <td>- White, facility for inscription, for terminal size 35 mm<sup>2</sup></td> <td>Accessories 9/13</td> </tr> <tr> <td>- For connection bars, transparent, for terminal size 16 and 35 mm<sup>2</sup></td> <td>Accessories 9/13</td> </tr> <tr> <td><b>Insulation plates, for terminal size 16 and 35 mm<sup>2</sup></b></td> <td>Accessories 9/14</td> </tr> <tr> <td><b>Connection bars, for terminal size 35 mm<sup>2</sup></b></td> <td></td> </tr> <tr> <td>- For two terminals</td> <td>Accessories 9/14</td> </tr> <tr> <td>- For three terminals</td> <td>Accessories 9/14</td> </tr> <tr> <td>- For ten terminals</td> <td>Accessories 9/14</td> </tr> <tr> <td><b>Barriers, for terminal size 35 mm<sup>2</sup></b></td> <td>Accessories 9/14</td> </tr> </tbody> </table>	Section	Page	<b>Covers</b>		- With lightning symbol, for terminal size 35 mm <sup>2</sup>	Accessories 9/13	- White, facility for inscription, for terminal size 35 mm <sup>2</sup>	Accessories 9/13	- For connection bars, transparent, for terminal size 16 and 35 mm <sup>2</sup>	Accessories 9/13	<b>Insulation plates, for terminal size 16 and 35 mm<sup>2</sup></b>	Accessories 9/14	<b>Connection bars, for terminal size 35 mm<sup>2</sup></b>		- For two terminals	Accessories 9/14	- For three terminals	Accessories 9/14	- For ten terminals	Accessories 9/14	<b>Barriers, for terminal size 35 mm<sup>2</sup></b>	Accessories 9/14	<p><b>8WA1 205</b> 20 units</p> <p><b>8WA1 011-1BM11</b> 10 units</p> <p><b>8WA1 305</b> 20 units</p> <hr/> <p><b>8WA1 813</b> 50 units</p> <p><b>8WA1 893</b> 50 units</p> <p><b>8WA1 822-7AX02</b> 10 units</p> <p><b>8WA1 822-7TK00</b> 50 units</p> <hr/> <p><b>8WA1 828</b> 20 units</p> <p><b>8WA1 803</b> 20 units</p> <p><b>8WA1 804</b> 10 units</p> <p><b>8WA1 823</b> 25 units</p>		
Section	Page																									
<b>Covers</b>																										
- With lightning symbol, for terminal size 35 mm <sup>2</sup>	Accessories 9/13																									
- White, facility for inscription, for terminal size 35 mm <sup>2</sup>	Accessories 9/13																									
- For connection bars, transparent, for terminal size 16 and 35 mm <sup>2</sup>	Accessories 9/13																									
<b>Insulation plates, for terminal size 16 and 35 mm<sup>2</sup></b>	Accessories 9/14																									
<b>Connection bars, for terminal size 35 mm<sup>2</sup></b>																										
- For two terminals	Accessories 9/14																									
- For three terminals	Accessories 9/14																									
- For ten terminals	Accessories 9/14																									
<b>Barriers, for terminal size 35 mm<sup>2</sup></b>	Accessories 9/14																									

Version		Order No.	MOQ*											
 <p>8WA1 011-1PM00</p>	<p><b>PE through-type terminals and through-type PEN terminals, terminal size 35 mm<sup>2</sup></b></p> <ul style="list-style-type: none"> <li>• Green/yellow</li> <li>• for I = 125 A</li> <li>• Mounting width 16 mm</li> <li>• Terminal height 50 mm</li> <li>• Terminal length 53 mm</li> <li>• Two screw terminals</li> <li>•  </li> </ul>	<b>8WA1 011-1PM00</b>	25 units											
	<table border="1"> <thead> <tr> <th>Accessories</th> <th>Section</th> <th>Page</th> </tr> </thead> <tbody> <tr> <td>Barriers, for terminal size 35 mm<sup>2</sup></td> <td>Accessories</td> <td>9/14</td> </tr> </tbody> </table>	Accessories	Section	Page	Barriers, for terminal size 35 mm <sup>2</sup>	Accessories	9/14	<b>8WA1 823</b>	25 units					
Accessories	Section	Page												
Barriers, for terminal size 35 mm <sup>2</sup>	Accessories	9/14												
<b>Terminal size 70 mm<sup>2</sup></b>														
 <p>8WA1 206</p>	<p><b>Through-type terminals, terminal size 70 mm<sup>2</sup></b></p> <ul style="list-style-type: none"> <li>• Rated uninterrupted current 192 A</li> <li>• Rated insulation voltage 800 V</li> <li>• Mounting width 25 mm</li> <li>• Terminal height 64.5 mm</li> <li>• Terminal length 73.5 mm</li> <li>•  AWG 8-3/0</li> <li>•  AWG 8-1/0</li> </ul>	<p><b>8WA1 206</b></p> <p><b>8WA1 011-1BP11</b></p>	<p>10/60 units</p> <p>10 units</p>											
	<table border="1"> <thead> <tr> <th>Accessories</th> <th>Section</th> <th>Page</th> </tr> </thead> <tbody> <tr> <td>Covers, with lightning symbol, for terminal size 70 mm<sup>2</sup></td> <td>Accessories</td> <td>9/13</td> </tr> <tr> <td>Connection bars, for terminal size 70 mm<sup>2</sup>, for 2 terminals</td> <td>Accessories</td> <td>9/14</td> </tr> <tr> <td>Barriers, for terminal size 70 mm<sup>2</sup></td> <td>Accessories</td> <td>9/14</td> </tr> </tbody> </table>			Accessories	Section	Page	Covers, with lightning symbol, for terminal size 70 mm <sup>2</sup>	Accessories	9/13	Connection bars, for terminal size 70 mm <sup>2</sup> , for 2 terminals	Accessories	9/14	Barriers, for terminal size 70 mm <sup>2</sup>	Accessories
Accessories	Section	Page												
Covers, with lightning symbol, for terminal size 70 mm <sup>2</sup>	Accessories	9/13												
Connection bars, for terminal size 70 mm <sup>2</sup> , for 2 terminals	Accessories	9/14												
Barriers, for terminal size 70 mm <sup>2</sup>	Accessories	9/14												
<b>Accessories</b>														
 <p>8WA1 810</p>	<p><b>Covers</b></p> <p>Versions</p> <ul style="list-style-type: none"> <li>• With lightning symbol                             <ul style="list-style-type: none"> <li>- For terminal size 1.5 ... 2.5 mm<sup>2</sup></li> <li>- For terminal sizes 4 and 6 mm<sup>2</sup></li> <li>- For terminal size 16 mm<sup>2</sup></li> <li>- For terminal size 35 mm<sup>2</sup></li> <li>- For terminal size 70 mm<sup>2</sup></li> </ul> </li> </ul>	<p><b>8WA1 810</b></p> <p><b>8WA1 811</b></p> <p><b>8WA1 812</b></p> <p><b>8WA1 813</b></p> <p><b>8WA1 814</b></p>	<p>50 units</p> <p>50 units</p> <p>50 units</p> <p>50 units</p> <p>50 units</p>											
	 <p>8WA1 860</p>			<ul style="list-style-type: none"> <li>• White, facility for inscription                             <ul style="list-style-type: none"> <li>- For terminal size 1.5 ... 2.5 mm<sup>2</sup></li> <li>- For terminal sizes 4 and 6 mm<sup>2</sup></li> <li>- For terminal size 16 mm<sup>2</sup></li> <li>- For terminal size 35 mm<sup>2</sup></li> </ul> </li> </ul>	<p><b>8WA1 860</b></p> <p><b>8WA1 862</b></p> <p><b>8WA1 892</b></p> <p><b>8WA1 893</b></p>	<p>50 units</p> <p>50 units</p> <p>50 units</p> <p>50 units</p>								
 <p>8WA1 822-7AX01</p>	<ul style="list-style-type: none"> <li>• For connection bars, transparent                             <ul style="list-style-type: none"> <li>- For terminal size 2.5 ... 6 mm<sup>2</sup></li> <li>- For terminal sizes 16 and 35 mm<sup>2</sup></li> </ul> </li> </ul>	<p><b>8WA1 822-7AX01</b></p> <p><b>8WA1 822-7AX02</b></p> <p><b>8WA1 822-7AX03</b></p>	<p>10 units</p> <p>10 units</p> <p>10 units</p>											
 <p>8WA1 822-7VF01</p>	<p><b>Jumpers</b></p> <p>For connection bars</p> <p>Versions</p> <ul style="list-style-type: none"> <li>• For terminal size 2.5 mm<sup>2</sup></li> <li>• For terminal size 4 mm<sup>2</sup></li> <li>• For terminal size 6 mm<sup>2</sup></li> </ul>			<p><b>8WA1 822-7VF01</b></p> <p><b>8WA1 822-7VG00</b></p> <p><b>8WA1 822-7VH00</b></p>	<p>50 units</p> <p>50 units</p> <p>50 units</p>									
 <p>8WA1 808</p>	<p><b>End retainers, thermoplastic</b></p> <p>Width 10 mm</p>	<b>8WA1 808</b>	50 units											

\* You can order this quantity or a multiple thereof.

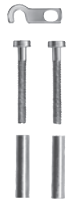
# 8WA1 Screw Terminals

## 8WA through-type terminals

Version	Order No.	MOQ*
 <p><b>Terminal strips</b></p> <ul style="list-style-type: none"> <li>• 6-pole</li> <li>• Labeled 1 to 6</li> </ul> <p>8WA1 741-2X</p>	<b>8WA1 741-2X</b>	5 units
 <p><b>Test sockets</b></p> <ul style="list-style-type: none"> <li>• Ø 2.3 mm</li> <li>• Up to 10 A</li> <li>• Terminal size 2.5 to 6 mm<sup>2</sup></li> </ul> <p>8WA1 854</p>	<b>8WA1 854</b>	100 units
 <p><b>Test plugs</b></p> <ul style="list-style-type: none"> <li>• For 8WA1 and 8WA2 terminals with 2.3 mm Ø hole or 8WA1 854, 8WA1 884 test sockets</li> <li>• Uninterrupted current 10 A</li> </ul> <p>8WA1 868</p>	<p><b>8WA1 868</b></p> <p><b>8WA1 870</b></p>	<p>10 units</p> <p>10 units</p>
 <p><b>Disconnecting links</b></p> <p>Up to 32 A</p> <p>Note</p> <p>Between terminals with terminal sizes 2.5 and 6 mm<sup>2</sup>, two 8WH1 820 barriers are required.</p> <p>8WA1 865</p>	<b>8WA1 865</b>	50 units
 <p><b>Insulation plates</b></p> <p>8WA1 825</p>	<p><b>8WA1 825</b></p> <p><b>8WA1 822-7TK00</b></p>	<p>50 units</p> <p>50 units</p>
 <p><b>Connection bars</b></p> <p>8WA1 895</p>	<p><b>8WA1 895</b></p> <p><b>8WA1 896</b></p> <p><b>8WA1 897</b></p> <p><b>8WA1 898</b></p> <p><b>8WA1 850</b></p> <p><b>8WA1 851</b></p> <p><b>8WA1 852</b></p> <p><b>8WA1 853</b></p> <p><b>8WA1 885</b></p> <p><b>8WA1 886</b></p> <p><b>8WA1 887</b></p> <p><b>8WA1 888</b></p> <p><b>8WA1 842</b></p> <p><b>8WA1 845</b></p> <p><b>8WA1 848</b></p> <p><b>8WA1 802</b></p> <p><b>8WA1 828</b></p> <p><b>8WA1 803</b></p> <p><b>8WA1 804</b></p> <p><b>8WA1 216</b></p>	<p>50 units</p> <p>50 units</p> <p>20 units</p> <p>10/200 units</p> <p>50 units</p> <p>50 units</p> <p>20 units</p> <p>10 units</p> <p>50 units</p> <p>50 units</p> <p>20 units</p> <p>10 units</p> <p>20 units</p> <p>20 units</p> <p>10 units</p> <p>20 units</p> <p>20 units</p> <p>10 units</p> <p>20 units</p>
 <p><b>Barriers</b></p> <p>8WA1 820</p>	<p><b>8WA1 820</b></p> <p><b>8WA1 821</b></p> <p><b>8WA1 823</b></p> <p><b>8WA1 824</b></p>	<p>50 units</p> <p>50 units</p> <p>25 units</p> <p>25 units</p>

### Overview









N-conductor isolating terminals permit an insulation test to be performed without disconnecting the neutral conductor according to DIN VDE 0108 and DIN VDE 0100 (Standards for the erection of power installations).

The branch terminals are used for the connection of lines (L), for example for power supplies, to the 6 mm x 6 mm busbar.

The rated voltage between two branch terminals (1 slide open) is 289 V.

When they are used as shield terminals according to DIN VDE 0160, they provide isolation between the central reference point (shield connection conductor) and the PE conductor.









### Selection and ordering data

Version	Order No.	MOQ*															
<p><b>General details</b></p> <ul style="list-style-type: none"> <li>• 1 screw terminal and connection to the neutral conductor bar or 6 mm x 6 mm busbar acc. to DIN 1761</li> <li>• Insulating body made of blue or beige thermoplastic</li> <li>• Enclosed at both ends</li> </ul> <table border="1"> <thead> <tr> <th>Note</th> <th>Section</th> <th>Page</th> </tr> </thead> <tbody> <tr> <td>For labeling accessories, see ...</td> <td>Accessories</td> <td>10/2</td> </tr> </tbody> </table>	Note	Section	Page	For labeling accessories, see ...	Accessories	10/2											
Note	Section	Page															
For labeling accessories, see ...	Accessories	10/2															
<b>Terminal size 2.5 mm<sup>2</sup></b>																	
 <p>8WA1 011-1NF01</p> <p><b>N-conductor isolating terminal, terminal size 2.5 mm<sup>2</sup></b></p> <ul style="list-style-type: none"> <li>• Blue</li> <li>• Rated uninterrupted current 24 A</li> <li>• Rated insulation voltage 500 V</li> <li>• Mounting width 6 mm</li> <li>• Terminal height 35 mm</li> <li>• Terminal length 55 mm</li> <li>• With built-in test socket in the fixed part of the terminal</li> <li>•  AWG 22-12</li> <li>•  AWG 22-12</li> </ul> <table border="1"> <thead> <tr> <th>Accessories</th> <th>Section</th> <th>Page</th> </tr> </thead> <tbody> <tr> <td>• Covers, for connection bars</td> <td>Accessories</td> <td>9/16</td> </tr> <tr> <td>• N-busbars, 6 mm x 6 mm</td> <td>Accessories</td> <td>9/16</td> </tr> <tr> <td>• Label holders</td> <td>Accessories</td> <td>9/16</td> </tr> </tbody> </table>	Accessories	Section	Page	• Covers, for connection bars	Accessories	9/16	• N-busbars, 6 mm x 6 mm	Accessories	9/16	• Label holders	Accessories	9/16	<p><b>8WA1 011-1NF01</b></p> <p>50 units</p>				
Accessories	Section	Page															
• Covers, for connection bars	Accessories	9/16															
• N-busbars, 6 mm x 6 mm	Accessories	9/16															
• Label holders	Accessories	9/16															
<table border="1"> <thead> <tr> <th>Accessories</th> <th>Section</th> <th>Page</th> </tr> </thead> <tbody> <tr> <td>• Covers, for connection bars</td> <td>Accessories</td> <td>9/16</td> </tr> <tr> <td>• N-busbars, 6 mm x 6 mm</td> <td>Accessories</td> <td>9/16</td> </tr> <tr> <td>• Label holders</td> <td>Accessories</td> <td>9/16</td> </tr> </tbody> </table>	Accessories	Section	Page	• Covers, for connection bars	Accessories	9/16	• N-busbars, 6 mm x 6 mm	Accessories	9/16	• Label holders	Accessories	9/16	<p><b>8WA1 822-7AX00</b></p> <p>10 units</p> <p><b>8GF9 324-2</b></p> <p>10 units</p> <p><b>3TX4 210-0J</b></p> <p>100 units</p>				
Accessories	Section	Page															
• Covers, for connection bars	Accessories	9/16															
• N-busbars, 6 mm x 6 mm	Accessories	9/16															
• Label holders	Accessories	9/16															
<p><b>Branch terminals, terminal size 2.5 mm<sup>2</sup></b></p> <ul style="list-style-type: none"> <li>• Beige</li> <li>• Isolating distance 400 V</li> <li>• Mounting width 6 mm</li> <li>• Terminal height 35 mm</li> <li>• Terminal length 55 mm</li> <li>• With built-in test socket in the fixed part of the terminal</li> <li>• Isolating distance</li> <li>•  AWG 22-12</li> <li>•  AWG 22-12</li> </ul> <table border="1"> <thead> <tr> <th>Accessories</th> <th>Section</th> <th>Page</th> </tr> </thead> <tbody> <tr> <td>• Covers, for connection bars</td> <td>Accessories</td> <td>9/16</td> </tr> <tr> <td>• N-busbars, 6 mm x 6 mm</td> <td>Accessories</td> <td>9/16</td> </tr> <tr> <td>• Label holders</td> <td>Accessories</td> <td>9/16</td> </tr> </tbody> </table>	Accessories	Section	Page	• Covers, for connection bars	Accessories	9/16	• N-busbars, 6 mm x 6 mm	Accessories	9/16	• Label holders	Accessories	9/16	<p><b>8WA1 011-1NF02</b></p> <p>50 units</p>				
Accessories	Section	Page															
• Covers, for connection bars	Accessories	9/16															
• N-busbars, 6 mm x 6 mm	Accessories	9/16															
• Label holders	Accessories	9/16															
<table border="1"> <thead> <tr> <th>Accessories</th> <th>Section</th> <th>Page</th> </tr> </thead> <tbody> <tr> <td>• Covers, for connection bars</td> <td>Accessories</td> <td>9/16</td> </tr> <tr> <td>• N-busbars, 6 mm x 6 mm</td> <td>Accessories</td> <td>9/16</td> </tr> <tr> <td>• Label holders</td> <td>Accessories</td> <td>9/16</td> </tr> </tbody> </table>	Accessories	Section	Page	• Covers, for connection bars	Accessories	9/16	• N-busbars, 6 mm x 6 mm	Accessories	9/16	• Label holders	Accessories	9/16	<p><b>8WA1 822-7AX00</b></p> <p>10 units</p> <p><b>8GF9 324-2</b></p> <p>10 units</p> <p><b>3TX4 210-0J</b></p> <p>100 units</p>				
Accessories	Section	Page															
• Covers, for connection bars	Accessories	9/16															
• N-busbars, 6 mm x 6 mm	Accessories	9/16															
• Label holders	Accessories	9/16															
<b>Terminal size 4 mm<sup>2</sup></b>																	
 <p>8WA1 011-1NG31</p> <p><b>N-conductor isolating terminal, terminal size 4 mm<sup>2</sup></b></p> <ul style="list-style-type: none"> <li>• Blue</li> <li>• Rated uninterrupted current 32 A</li> <li>• Rated insulation voltage 500 V</li> <li>• Mounting width 6.5 mm</li> <li>• Terminal height 35 mm</li> <li>• Terminal length 55 mm</li> <li>• With built-in test socket in the fixed part of the terminal</li> <li>•  AWG 18-10</li> <li>•  AWG 18-10</li> </ul> <table border="1"> <thead> <tr> <th>Accessories</th> <th>Section</th> <th>Page</th> </tr> </thead> <tbody> <tr> <td>• Covers, for connection bars</td> <td>Accessories</td> <td>9/16</td> </tr> <tr> <td>• Feeder terminals, for N-busbars</td> <td>Accessories</td> <td>9/16</td> </tr> <tr> <td>• N-busbars, 6 mm x 6 mm</td> <td>Accessories</td> <td>9/16</td> </tr> <tr> <td>• Label holders</td> <td>Accessories</td> <td>9/16</td> </tr> </tbody> </table>	Accessories	Section	Page	• Covers, for connection bars	Accessories	9/16	• Feeder terminals, for N-busbars	Accessories	9/16	• N-busbars, 6 mm x 6 mm	Accessories	9/16	• Label holders	Accessories	9/16	<p><b>8WA1 011-1NG31</b></p> <p>50 units</p>	
Accessories	Section	Page															
• Covers, for connection bars	Accessories	9/16															
• Feeder terminals, for N-busbars	Accessories	9/16															
• N-busbars, 6 mm x 6 mm	Accessories	9/16															
• Label holders	Accessories	9/16															
<table border="1"> <thead> <tr> <th>Accessories</th> <th>Section</th> <th>Page</th> </tr> </thead> <tbody> <tr> <td>• Covers, for connection bars</td> <td>Accessories</td> <td>9/16</td> </tr> <tr> <td>• Feeder terminals, for N-busbars</td> <td>Accessories</td> <td>9/16</td> </tr> <tr> <td>• N-busbars, 6 mm x 6 mm</td> <td>Accessories</td> <td>9/16</td> </tr> <tr> <td>• Label holders</td> <td>Accessories</td> <td>9/16</td> </tr> </tbody> </table>	Accessories	Section	Page	• Covers, for connection bars	Accessories	9/16	• Feeder terminals, for N-busbars	Accessories	9/16	• N-busbars, 6 mm x 6 mm	Accessories	9/16	• Label holders	Accessories	9/16	<p><b>8WA1 822-7AX00</b></p> <p>10 units</p> <p><b>8WA2 867</b></p> <p>50 units</p> <p><b>8GF9 324-2</b></p> <p>10 units</p> <p><b>3TX4 210-0J</b></p> <p>100 units</p>	
Accessories	Section	Page															
• Covers, for connection bars	Accessories	9/16															
• Feeder terminals, for N-busbars	Accessories	9/16															
• N-busbars, 6 mm x 6 mm	Accessories	9/16															
• Label holders	Accessories	9/16															

\* You can order this quantity or a multiple thereof.

# 8WA1 Screw Terminals

## 8WA N-conductor isolating and branch terminals

Version	Order No.	MOQ*															
<b>Terminal size 6 mm<sup>2</sup></b>																	
 <p>8WA1 011-1NH01</p> <p><b>N-conductor isolating terminals, terminal size 6 mm<sup>2</sup></b></p> <ul style="list-style-type: none"> <li>• Blue</li> <li>• Rated uninterrupted current 41 A</li> <li>• Rated insulation voltage 500 V</li> <li>• Mounting width 8 mm</li> <li>• Terminal height 35 mm</li> <li>• Terminal length 55 mm</li> <li>• With built-in test socket in the fixed part of the terminal</li> <li>•  AWG 14-8</li> <li>•  AWG 14-8</li> </ul> <table border="1"> <thead> <tr> <th>Accessories</th> <th>Section</th> <th>Page</th> </tr> </thead> <tbody> <tr> <td>• Covers, for connection bars</td> <td>Accessories</td> <td>9/16</td> </tr> <tr> <td>• N-busbars, 6 mm × 6 mm</td> <td>Accessories</td> <td>9/16</td> </tr> <tr> <td>• Label holders</td> <td>Accessories</td> <td>9/16</td> </tr> </tbody> </table>	Accessories	Section	Page	• Covers, for connection bars	Accessories	9/16	• N-busbars, 6 mm × 6 mm	Accessories	9/16	• Label holders	Accessories	9/16	<p><b>8WA1 011-1NH01</b></p> <p>50 units</p>				
Accessories	Section	Page															
• Covers, for connection bars	Accessories	9/16															
• N-busbars, 6 mm × 6 mm	Accessories	9/16															
• Label holders	Accessories	9/16															
	<p><b>8WA1 822-7AX00</b></p> <p><b>8GF9 324-2</b></p> <p><b>3TX4 210-0J</b></p>	<p>10 units</p> <p>10 units</p> <p>100 units</p>															
<b>Terminal size 16 mm<sup>2</sup></b>																	
 <p>8WA1 604</p> <p><b>N-conductor isolating terminals, terminal size 16 mm<sup>2</sup></b></p> <ul style="list-style-type: none"> <li>• Blue</li> <li>• Rated uninterrupted current 76 A</li> <li>• Rated insulation voltage 500 V</li> <li>• Mounting width 10 mm</li> <li>• Terminal height 35 mm</li> <li>• Terminal length 55 mm</li> <li>•  AWG 12-4</li> </ul> <table border="1"> <thead> <tr> <th>Accessories</th> <th>Section</th> <th>Page</th> </tr> </thead> <tbody> <tr> <td>• Covers, for connection bars</td> <td>Accessories</td> <td>9/16</td> </tr> <tr> <td>• Feeder terminals, for N-busbars</td> <td>Accessories</td> <td>9/16</td> </tr> <tr> <td>• N-busbars, 6 mm × 6 mm</td> <td>Accessories</td> <td>9/16</td> </tr> <tr> <td>• Label holders</td> <td>Accessories</td> <td>9/16</td> </tr> </tbody> </table>	Accessories	Section	Page	• Covers, for connection bars	Accessories	9/16	• Feeder terminals, for N-busbars	Accessories	9/16	• N-busbars, 6 mm × 6 mm	Accessories	9/16	• Label holders	Accessories	9/16	<p><b>8WA1 604</b></p> <p>50 units</p>	
Accessories	Section	Page															
• Covers, for connection bars	Accessories	9/16															
• Feeder terminals, for N-busbars	Accessories	9/16															
• N-busbars, 6 mm × 6 mm	Accessories	9/16															
• Label holders	Accessories	9/16															
	<p><b>8WA1 822-7AX00</b></p> <p><b>8WA2 868</b></p> <p><b>8GF9 324-2</b></p> <p><b>3TX4 210-0J</b></p>	<p>10 units</p> <p>50 units</p> <p>10 units</p> <p>100 units</p>															
	<p><b>Branch terminals, terminal size 16 mm<sup>2</sup></b></p> <ul style="list-style-type: none"> <li>• Beige</li> <li>• Isolating distance 400 V</li> <li>• Mounting width 10 mm</li> <li>• Isolating distance</li> <li>•  AWG 12-4</li> </ul> <table border="1"> <thead> <tr> <th>Accessories</th> <th>Section</th> <th>Page</th> </tr> </thead> <tbody> <tr> <td>• Covers, for connection bars</td> <td>Accessories</td> <td>9/16</td> </tr> <tr> <td>• N-busbars, 6 mm × 6 mm</td> <td>Accessories</td> <td>9/16</td> </tr> <tr> <td>• Label holders</td> <td>Accessories</td> <td>9/16</td> </tr> </tbody> </table>	Accessories	Section	Page	• Covers, for connection bars	Accessories	9/16	• N-busbars, 6 mm × 6 mm	Accessories	9/16	• Label holders	Accessories	9/16	<p><b>8WA1 011-1NK02</b></p> <p>50 units</p>			
Accessories	Section	Page															
• Covers, for connection bars	Accessories	9/16															
• N-busbars, 6 mm × 6 mm	Accessories	9/16															
• Label holders	Accessories	9/16															
	<p><b>8WA1 822-7AX00</b></p> <p><b>8GF9 324-2</b></p> <p><b>3TX4 210-0J</b></p>	<p>10 units</p> <p>10 units</p> <p>100 units</p>															
<b>Accessories</b>																	
 <p>8WA1 822-7AX00</p> <p><b>Covers, for connection bars</b></p> <ul style="list-style-type: none"> <li>• Not for 8WA1 604 and 8WA1 011-1NK02</li> <li>• Length 155 mm</li> </ul>	<p><b>8WA1 822-7AX00</b></p> <p>10 units</p>																
 <p>8WA2 870 / 868 / 867</p> <p><b>Feeder terminals, for N-busbars</b></p> <ul style="list-style-type: none"> <li>• 6 × 6 mm and 10 × 3 mm</li> <li>• Bare</li> </ul> <table border="1"> <thead> <tr> <th>Versions</th> </tr> </thead> <tbody> <tr> <td>• Rated uninterrupted current 32 A, for connection of up to 4 mm<sup>2</sup></td> </tr> <tr> <td>• Rated uninterrupted current 76 A, for connection of up to 25 mm<sup>2</sup></td> </tr> <tr> <td>• Rated uninterrupted current 125 A, for connection of up to 35 mm<sup>2</sup></td> </tr> </tbody> </table>	Versions	• Rated uninterrupted current 32 A, for connection of up to 4 mm <sup>2</sup>	• Rated uninterrupted current 76 A, for connection of up to 25 mm <sup>2</sup>	• Rated uninterrupted current 125 A, for connection of up to 35 mm <sup>2</sup>	<p><b>8WA2 867</b></p> <p>50 units</p> <p><b>8WA2 868</b></p> <p>50 units</p> <p><b>8WA2 870</b></p> <p>50 units</p>												
Versions																	
• Rated uninterrupted current 32 A, for connection of up to 4 mm <sup>2</sup>																	
• Rated uninterrupted current 76 A, for connection of up to 25 mm <sup>2</sup>																	
• Rated uninterrupted current 125 A, for connection of up to 35 mm <sup>2</sup>																	
 <p>8GF9 324-2</p> <p><b>N-busbars, 6 mm × 6 mm</b></p> <ul style="list-style-type: none"> <li>• Rated uninterrupted current 125 A</li> <li>• 1109 mm long</li> <li>• For four-field</li> </ul> <table border="1"> <thead> <tr> <th>Note</th> </tr> </thead> <tbody> <tr> <td>Prices apply for orders from € 25.00. For orders below € 25.00, a processing charge of € 2.50 net will be added.</td> </tr> </tbody> </table>	Note	Prices apply for orders from € 25.00. For orders below € 25.00, a processing charge of € 2.50 net will be added.	<p><b>8GF9 324-2</b></p> <p>10 units</p>														
Note																	
Prices apply for orders from € 25.00. For orders below € 25.00, a processing charge of € 2.50 net will be added.																	
	<p><b>Label holders</b></p> <p><b>3TX4 210-0J</b></p>	<p>100 units</p>															

### Overview

The Insta or three-tier terminals incorporate up to 3 different terminal functions in one insulating body of 6 mm width. The width of 3 Insta terminals corresponds to the modular width of 18 mm standardized in distribution board assembly. **Tools are required to remove the terminals from the support rail.**

All clamping points for incoming and outgoing cables have a cutout for an 8WA8 8.. label. The protective conductor connections are already marked green-yellow and the neutral conductor connections blue.

The N-busbar has the same position for Insta terminals and N-conductor isolating terminals. This allows, for example, the use of a 16 mm<sup>2</sup> N-conductor isolating terminal as an infeed for the N-busbar.

8WA1 011-3JF16, -3JF17 and -3JF18 allow the N-busbar to be routed with a mounting depth of 42.5 mm.

#### PE, L, NT Insta terminal

The 8WA1 011-3JF20 terminal is the basic version for AC circuits. It comprises:

- Protective conductor connection
- Through-type connection for one phase conductor
- Neutral conductor connection that can be isolated from the 6 mm × 6 mm N-busbar.

#### PE, L, N Insta terminals

If no neutral conductor isolation is required, the 8WA1 011-3JF17 terminal is used:

- Protective conductor connection
- Through-type connection for one phase conductor
- Through-type connection for the neutral conductor



#### PE, L, L Insta terminal

Design of 8WA1 011-3JF16 terminal as previous version. Instead of the through-type connection for the neutral conductor, a through-type connection for a second phase conductor is fitted.

#### L, L Insta terminal

8WA1 011-3JF18 terminal contains two through-type connections for two phase conductors. These are generally used for three-phase outgoing lines.

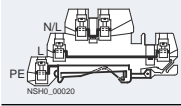
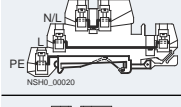
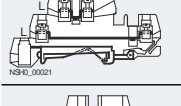



### Selection and ordering data

Version	Order No.	MOQ*
<b>General details</b> <ul style="list-style-type: none"> <li>• Thermoplastic insulating body</li> <li>• Screw terminal at both ends</li> <li>• Enclosed at both ends</li> <li>• Neutral terminal, 6 mm × 6 mm neutral conductor connection</li> </ul>		
Note	Section	Page
For labeling accessories, see ...	Accessories	10/2
<b>Terminal size 2.5 mm<sup>2</sup></b>		
 <p>8WA1 011-3JF16</p>		
<b>Insta terminals, terminal size 2.5 mm<sup>2</sup></b> <ul style="list-style-type: none"> <li>• Rated uninterrupted current 24 A</li> <li>• Rated insulation voltage                             <ul style="list-style-type: none"> <li>- 400 V between phase conductors</li> <li>- 250 V between phase and protective conductors and for neutral isolating distance</li> </ul> </li> <li>• Mounting width 6 mm</li> <li>• Terminal height 42.5 mm</li> <li>• Terminal length 87 mm</li> <li>• Screw terminals at both ends</li> <li>• AWG 22-12</li> </ul>		
Circuit diagram	Type	
	PE, L, L	
	PE, L, N	
	L, L	
	PE, L, NT	
Accessories	Section	Page
Barriers, for Insta terminals, terminal size 2.5 mm and measuring transformer terminals, terminal size 6	Accessories	9/18
	<b>8WA1 011-3JF16</b>	50 units
	<b>8WA1 011-3JF17</b>	50 units
	<b>8WA1 011-3JF18</b>	50 units
	<b>8WA1 011-3JF20</b>	50 units
	<b>8WA1 822-7TH00</b>	50 units

\* You can order this quantity or a multiple thereof.

# 8WA1 Screw Terminals

## 8WA Insta or three-tier terminals

	Version	Order No.	MOQ*
<b>Accessories</b>			
	<b>Covers</b> Up to three terminals side-by-side <b>Versions</b> <ul style="list-style-type: none"> <li>• With lightning symbol, for terminal size 4 and 6 mm<sup>2</sup></li> <li>• White, facility for inscription, for terminal size 4 and 6 mm<sup>2</sup></li> <li>• For connection bars, for terminal size 2.5 to 6 mm<sup>2</sup> <ul style="list-style-type: none"> <li>- Transparent</li> <li>- White</li> </ul> </li> </ul>	<b>8WA1 811</b> <b>8WA1 862</b>  <b>8WA1 822-7AX01</b> <b>8WA1 822-7AX03</b>	50 units 50 units  10 units 10 units
 8WA2 870 / 868 / 867	<b>Feeder terminals, for N-busbars</b> <ul style="list-style-type: none"> <li>• 6 mm × 6 mm and 10 mm × 3 mm</li> <li>• Bare</li> </ul> <b>Versions</b> <ul style="list-style-type: none"> <li>• Connection up to 4 mm<sup>2</sup></li> <li>• Connection up to 25 mm<sup>2</sup></li> <li>• Connection up to 35 mm<sup>2</sup></li> </ul>	<b>8WA2 867</b> <b>8WA2 868</b> <b>8WA2 870</b>	50 units 50 units 50 units
 8WA1 808	<b>End retainers, thermoplastic</b> Width 10 mm	<b>8WA1 808</b>	50 units
	<b>Device labels</b> For end retainer, blank label	<b>3TX4 210-0H</b>	100 units
 8WA1 857	<b>Insulation carriers, for mounting insulated support rails</b>	<b>8WA1 857</b>	20 units
	<b>Blank labels</b> For terminal marking	<b>8WA8 848-2AY</b>	100 units
 8GF9 324-2	<b>N-busbars, 6 mm × 6 mm</b> <ul style="list-style-type: none"> <li>• Rated uninterrupted current 125 A</li> <li>• 1109 mm long</li> <li>• For four-field</li> </ul> <b>Note</b> Prices apply for orders from € 25.00. For orders below € 25.00, a processing charge of € 2.50 net will be added.	<b>8GF9 324-2</b>	10 units
	<b>Connection bars, for Insta terminals</b> <b>Versions</b> <ul style="list-style-type: none"> <li>• For two terminals</li> <li>• For three terminals</li> <li>• For four terminals</li> <li>• For ten terminals</li> </ul>	<b>8WA1 822-7VF02</b> <b>8WA1 822-7VF03</b> <b>8WA1 822-7VF04</b> <b>8WA1 822-7VF10</b>	50 units 50 units 20 units 10 units
	<b>Barriers, for Insta terminals, terminal size 2.5 mm<sup>2</sup> and measuring transformer terminals, terminal size 6 mm<sup>2</sup></b>	<b>8WA1 822-7TH00</b>	50 units

### Overview

Two-tier terminals are a compact form of the terminal blocks. They are therefore open on one side. They can contain two connecting cables with two connections each or they can be laid out as terminal blocks with four connections on the same potential.

An advantage is the standardized front for mounting, linking and labeling.

### Technical specifications

	Rated voltage	
	AC	DC
Between connection bars		
• With insulation plate	400 V	450 V
• With end plate or barrier	800 V	900 V
• With disconnecting link opened	500 V	600 V
For alternately bent soldering tags	400 V	450 V
For adjacent terminals with soldering tags and insulated plugs	250 V	300 V

### Selection and ordering data

Version	Order No.	MOQ*
<b>General details</b> <ul style="list-style-type: none"> <li>Thermoplastic insulating body</li> <li>Screw terminal at both ends</li> </ul>		
Note	Section	Page
For labeling accessories, see ...	Accessories	10/2

#### Terminal size 4 mm<sup>2</sup>

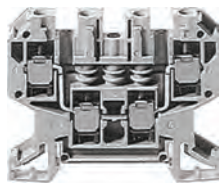

8WA1 011-6DG11

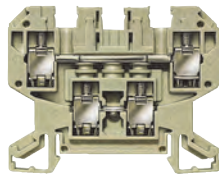

8WA1 011-2DG11

#### Two-tier terminals, terminal size 4 mm<sup>2</sup>

- Rated uninterrupted current 32 A
- Rated insulation voltage 690 V (with end plate 800 V)
- Mounting width 6.5 mm
- Terminal height 45 mm
- Terminal length 64 mm
- AWG 18-10
- AWG 18-10

#### Versions

- Beige
  - 1-pole
  - 2-pole, with two isolated connections
- Blue
  - 1-pole
  - 2-pole, with two isolated connections

#### Accessories







- Covers**
  - With lightning symbol, for terminal size 4 and 6 mm<sup>2</sup>
  - White, facility for inscription, for terminal size 4 and 6 mm<sup>2</sup>
  - For connection bars, for terminal size 2.5 to 6 mm<sup>2</sup>, transparent
- Jumpers**
  - For upper tier of 2-pole terminals
  - For lower tier of 1 and 2-pole terminals
- Spacer sleeves**
- End plates**
- Test sockets**
  - For upper tier of 2-pole terminals
  - For lower tier of 1 and 2-pole terminals
- Disconnecting links**
- Insulation plates**
  - For upper tier of 2-pole terminals
  - For lower tier of 1 and 2-pole terminals
- Connection bars**
  - For upper tier of 2-pole terminals
    - For two terminals
    - For three terminals
    - For four terminals
    - For ten terminals
  - For lower tier of 1 and 2-pole terminals
    - For two terminals
    - For ten terminals
- Barriers**

<b>8WA1 011-6DG11</b>	50 units
<b>8WA1 011-2DG11</b>	50 units
<b>8WA1 011-6BG11</b>	50 units
<b>8WA1 011-2BG11</b>	50 units
<b>8WA1 811</b>	50 units
<b>8WA1 862</b>	50 units
<b>8WA1 822-7AX01</b>	10 units
<b>8WA1 822-7VG00</b>	50 units
<b>8WA1 822-7VG01</b>	50 units
<b>8WA1 822-7VH11</b>	100 units
<b>8WA1 817</b>	50 units
<b>8WA1 854</b>	100 units
<b>8WA1 884</b>	100 units
<b>8WA1 865</b>	50 units
<b>8WA1 825</b>	50 units
<b>8WA1 825</b>	50 units
<b>8WA1 850</b>	50 units
<b>8WA1 851</b>	50 units
<b>8WA1 852</b>	20 units
<b>8WA1 853</b>	10 units
<b>8WA1 835</b>	50 units
<b>8WA1 838</b>	10 units
<b>8WA1 823</b>	25 units

\* You can order this quantity or a multiple thereof.

# 8WA1 Screw Terminals

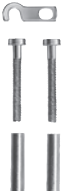
## 8WA two-tier terminals

Version	Order No.	MOQ*
<b>Accessories</b>		
<b>Covers</b>		
Versions		
 8WA1 811	<ul style="list-style-type: none"> <li>With lightning symbol, for terminal size 4 and 6 mm<sup>2</sup></li> </ul>	8WA1 811 50 units
 8WA1 862	<ul style="list-style-type: none"> <li>White, facility for inscription, for terminal size 4 and 6 mm<sup>2</sup></li> </ul>	8WA1 862 50 units
 8WA1 822-7AX01	<ul style="list-style-type: none"> <li>For connection bars, for terminal size 2.5 to 6 mm<sup>2</sup>, transparent</li> </ul>	8WA1 822-7AX01 10 units
<b>Jumpers</b>		
<ul style="list-style-type: none"> <li>For connection bars</li> <li>For terminal size 4 mm<sup>2</sup></li> </ul>		
Versions		
<ul style="list-style-type: none"> <li>For upper tier of 2-pole terminals</li> <li>For lower tier of 1 and 2-pole terminals</li> </ul>		
<b>End plates, for two-tier terminals</b>		
8WA1 817 50 units		
<b>Test sockets</b>		
Ø 2.3 mm		
Versions		
 8WA1 854	<ul style="list-style-type: none"> <li>For upper tier of 2-pole terminals</li> <li>For lower tier of 1 and 2-pole terminals</li> </ul>	8WA1 854 100 units 8WA1 884 100 units
Accessories		
Spacer sleeves		
<ul style="list-style-type: none"> <li>For lower tier of 1 and 2-pole terminals</li> <li>Suitable for 2.3 mm test socket</li> </ul>		
<b>Disconnecting links</b>		
For upper tier of 2-pole terminals		
Note		
The terminals must be fitted with end plates and must be fitted with the end plates facing each other.		
 8WA1 865		8WA1 865 50 units
<b>Insulation plates, for terminal size 2.5 to 6 mm<sup>2</sup></b>		
 8WA1 825		8WA1 825 50 units
<b>Connection bars</b>		
Versions		
<ul style="list-style-type: none"> <li>For upper tier of 2-pole terminals               <ul style="list-style-type: none"> <li>For two terminals</li> <li>For three terminals</li> <li>For four terminals</li> <li>For ten terminals</li> </ul> </li> <li>For lower tier of 1 and 2-pole terminals               <ul style="list-style-type: none"> <li>For two terminals</li> <li>For ten terminals</li> </ul> </li> </ul>		
8WA1 850 50 units 8WA1 851 50 units 8WA1 852 20 units 8WA1 853 10 units		
8WA1 835 50 units 8WA1 838 10 units		
<b>Barriers</b>		
 8WA1 823		8WA1 823 25 units

## Design

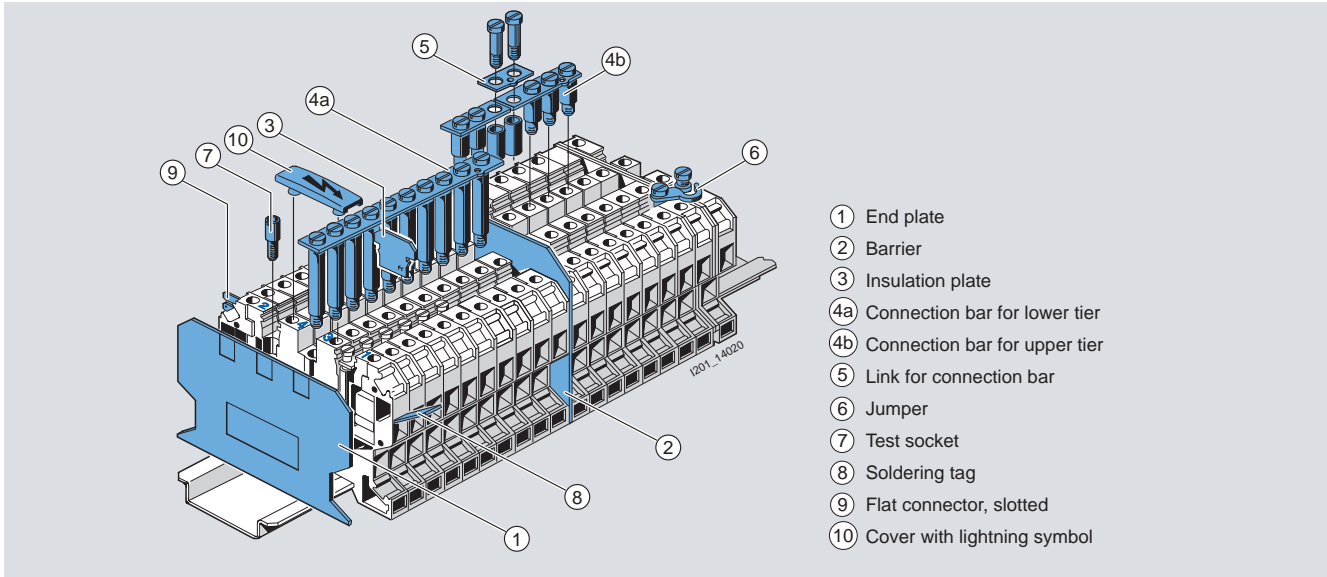

## Selection and ordering data

Version	Order No.	MOQ*
<b>General details</b> <ul style="list-style-type: none"> <li>Thermoplastic insulating body</li> <li>Screw terminal at both ends</li> <li>Open on one side</li> <li>Beige</li> </ul>		
Note	Section	Page
For labeling accessories, see ...	Accessories	10/2

### Terminal size 4 mm<sup>2</sup>

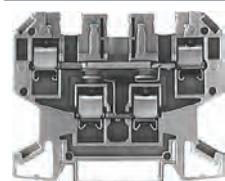

8WA1 011-6EG20

#### Diode terminals, terminal size 4 mm<sup>2</sup>

- Rated insulation voltage 250 V
- Mounting width 6.5 mm
- Terminal height 45 mm
- Terminal length 64 mm
- AWG 18-10
- Jumpering not supported

Type	Order No.	MOQ*
<ul style="list-style-type: none"> <li>Rated uninterrupted current 32/1 A</li> </ul>	<b>8WA1 011-6EG20</b>	10 units
<ul style="list-style-type: none"> <li>Rated uninterrupted current 32/1 A</li> </ul>	<b>8WA1 011-6EG21</b>	10 units
<ul style="list-style-type: none"> <li>Rated uninterrupted current 1 A</li> </ul>	<b>8WA1 011-6EG22</b>	10 units
<ul style="list-style-type: none"> <li>Rated uninterrupted current 32/1 A</li> </ul>	<b>8WA1 011-6EG23</b>	10 units
<ul style="list-style-type: none"> <li>Rated uninterrupted current 32/1 A</li> </ul>	<b>8WA1 011-6EG24</b>	10 units
Accessories	Section	Page
End plates, for two-tier terminals	Accessories	9/22
	<b>8WA1 817</b>	50 units



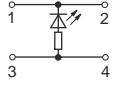
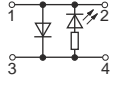
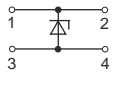

\* You can order this quantity or a multiple thereof.

# 8WA1 Screw Terminals

## 8WA1 two-tier terminals with electronic components

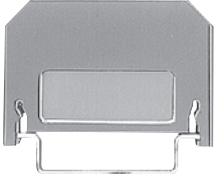
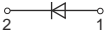
Version	Order No.	MOQ*				
<p><b>Terminals with red LED, terminal size 4 mm<sup>2</sup></b></p> <ul style="list-style-type: none"> <li>Rated uninterrupted current 32 A</li> <li>Rated insulation voltage 24 V DC</li> <li>Mounting width 6.5 mm</li> <li>Terminal height 45 mm</li> <li>Terminal length 64 mm</li> <li>AWG 18-10</li> </ul>						
<p>Type</p> <ul style="list-style-type: none"> <li>Without diode for current limitation</li> </ul> 	<b>8WA1 011-6EG25</b>	10 units				
<ul style="list-style-type: none"> <li>With diode for current limitation</li> </ul> 	<b>8WA1 011-6EG26</b>	10 units				
<p>Accessories</p> <p>End plates, for two-tier terminals</p> 	<table border="1"> <thead> <tr> <th>Section</th> <th>Page</th> </tr> </thead> <tbody> <tr> <td>Accessories</td> <td>9/22</td> </tr> </tbody> </table>	Section	Page	Accessories	9/22	<p><b>8WA1 817</b></p> <p>50 units</p>
Section	Page					
Accessories	9/22					
<p><b>Zener diode terminals, terminal size 4 mm<sup>2</sup></b></p> <ul style="list-style-type: none"> <li>Mounting width 6.5 mm</li> <li>Terminal height 45 mm</li> <li>Terminal length 64 mm</li> <li>AWG 18-10</li> <li>Let-through current 0.25 A</li> <li>Avalanche voltage <math>U_Z = 2.4 \text{ V}, \pm 5 \%</math></li> </ul>						
<p>Accessories</p> <p>End plates, for two-tier terminals</p>	<table border="1"> <thead> <tr> <th>Section</th> <th>Page</th> </tr> </thead> <tbody> <tr> <td>Accessories</td> <td>9/22</td> </tr> </tbody> </table>	Section	Page	Accessories	9/22	<p><b>8WA1 817</b></p> <p>50 units</p>
Section	Page					
Accessories	9/22					
<p><b>Accessories</b></p> <p>End plates, for two-tier terminals</p>	<b>8WA1 817</b>	50 units				

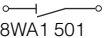
### Selection and ordering data

Version	Order No.	MOQ*
<b>General details</b> <ul style="list-style-type: none"> <li>Thermoplastic insulating body</li> <li>Enclosed at both ends</li> </ul>		
Note	Section	Page
For labeling accessories, see ...	Accessories	10/2
<b>Terminal size 2.5 mm<sup>2</sup></b>		
 <p>8WA1 011-1EF20</p>  <p>8WA1 011-1EF20</p>	<b>Diode terminals, terminal size 2.5 mm<sup>2</sup></b> <ul style="list-style-type: none"> <li>Rated insulation voltage 250 V U<sub>RRM</sub></li> <li>Mounting width 6 mm</li> <li>Terminal height 26 mm</li> <li>Terminal length 41 mm</li> <li>Screw terminals at both ends with test options for Ø 2.3 mm test plug</li> <li>Rated uninterrupted current 1 A</li> <li>Peak blocking voltage 1000 V</li> </ul>	<b>8WA1 011-1EF20</b> 5 units
Accessories	Section	Page
<ul style="list-style-type: none"> <li>Test plugs</li> <li>Barriers, for terminal size 1.5 to 4 mm<sup>2</sup></li> </ul>	Accessories	9/23
	Accessories	9/23
 <p>8WA1 501</p>  <p>8WA1 501</p>	<b>Through-type terminals, terminal size 2.5 mm<sup>2</sup>, with sectionalizing feature</b> <ul style="list-style-type: none"> <li>Rated uninterrupted current 10 A</li> <li>Rated insulation voltage 380 V AC, 450 V DC (with alternate outgoing soldering tags)               <ul style="list-style-type: none"> <li>Open isolating distance 380 V AC, 450 V DC</li> <li>For use of barriers up to 750 V AC, 900 V DC</li> </ul> </li> <li>Mounting width 6 mm</li> <li>Terminal height 29 mm</li> <li>Terminal length 41 mm</li> <li>With 2 holes for Ø 2.3 mm test plug</li> <li>With screw terminals at both ends</li> </ul>	<b>8WA1 501</b> 10 units
Note	Through-type terminals with sectionalizing feature allow easy isolation of the current path without disconnection of conductors. The sockets of the terminal screws allow actions, such as the measuring of the loop resistance or connection of an ammeter to the circuit. The use of connection combs reduces the conductor cross-section by one level.	
Accessories	Section	Page
<ul style="list-style-type: none"> <li>Test plugs, red</li> <li>Barriers, for terminal size 1.5 to 4 mm<sup>2</sup></li> </ul>	Accessories	9/23
	Accessories	9/23
<b>Accessories</b>		
 <p>8WA1 868</p>	<b>Test plugs</b> Red	<b>8WA1 868</b> 10 units
 <p>8WA1 820</p>	<b>Barriers, for terminal size 1.5 to 4 mm<sup>2</sup></b>	<b>8WA1 820</b> 50 units

\* You can order this quantity or a multiple thereof.

# 8WA1 Screw Terminals

## 8WA terminals for components

### Selection and ordering data

Version	Order No.	MOQ*						
<p><b>General details</b></p> <ul style="list-style-type: none"> <li>• Terminals for components</li> <li>• Screw terminal at both ends for 2 conductors each</li> <li>• Plugs with PCB for components</li> <li>• Enclosed at both ends</li> </ul> <table border="1"> <thead> <tr> <th>Note</th> <th>Section</th> <th>Page</th> </tr> </thead> <tbody> <tr> <td>For labeling accessories, see ...</td> <td>Accessories</td> <td>10/2</td> </tr> </tbody> </table>	Note	Section	Page	For labeling accessories, see ...	Accessories	10/2		
Note	Section	Page						
For labeling accessories, see ...	Accessories	10/2						

#### Terminal size 1.5 mm<sup>2</sup>



8WA1 011-1EE00

#### Terminals for components, terminal size 1.5 mm<sup>2</sup> (enclosure only)

- Rated uninterrupted current 6.3 A
- Rated insulation voltage 500 V
- Mounting width 10 mm
- Terminal height 40 mm
- Terminal length 57 mm
- For self-fitting with components
- To next terminal, determined internally through customer's components

**8WA1 011-1EE00**

5/50 units



8WA1 822-7EE00

#### Plugs for components, terminal size 1.5 mm<sup>2</sup>

- Rated uninterrupted current 6.3 A
- Rated insulation voltage 500 V
- Mounting width 10 mm
- Plug height 29 mm
- Plug length 41 mm
- With PCB and inscription label (20 mm × 9 mm)

**8WA1 822-7EE00**

1 unit

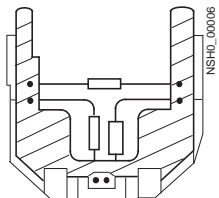

Plugs, fully equipped, example

### Dimensional drawings

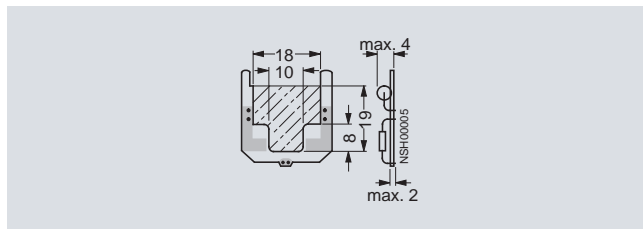

Space for components

### Overview

8WA1 011-1SF12 fuse terminals are used to protect control circuits against short-circuits.

The fuse terminals are intended for 5 mm × 20 mm and 5 mm × 25 mm G fuse links up to 6.3 A and 250 V and for bridging links up to 16 A and 800 V and have a mounting for a replacement fuse link.

The fuse terminals are suitable for fuse links, sizes 1/4" × 1", 1/4" × 1 1/4" (6.3 mm × 32 mm) to 6.3 A and 250 V.

Fuse terminals are positive opening fuse-disconnectors.





The fuse links must be replaced at zero voltage. Finger safety is ensured in both closed and open positions.

The LED indicates the status of the disconnected fuse (residual current from 2 mA to 5 mA), but not if the plug is removed (floating).

The double connection is designed so that two conductors with different cross-sections can also be securely connected.

The fixing base of the G fuse terminal allows both centered and recessed mounting, allowing the unhindered routing of a 6 mm × 6 mm N-busbar. The G fuse terminal can therefore be joined into a single group with the other terminals of a branch.

### Selection and ordering data







Version	Order No.	MOQ*
<b>General details</b> <ul style="list-style-type: none"> <li>• With thermoplastic insulating body</li> <li>• Screw terminal at both ends for 2 conductors each</li> <li>• Enclosed at both ends</li> </ul>		
<b>Note</b> For labeling accessories, see ...	<b>Section</b> Accessories	<b>Page</b> 10/2
<b>Terminal size 1.5 mm<sup>2</sup></b>		
 <p>8WA1 011-1SF12</p>	<b>Fuse terminals, terminal size 1.5 mm<sup>2</sup></b> <ul style="list-style-type: none"> <li>• Rated uninterrupted current 6.3 A when using fuses</li> <li>• Rated uninterrupted current 16 A when using the bridging link</li> <li>• Rated uninterrupted voltage 250 V when using fuses</li> <li>• Rated insulation voltage 800 V when using the bridging link</li> <li>• Mounting width 10 mm</li> <li>• Terminal height 42 mm</li> <li>• Terminal length 57 mm</li> <li>• Open isolating distance 500 V</li> <li>• AWG 18-14</li> <li>• @ AWG 18-14</li> </ul>	
 <p>8WA1 011-1SF13</p>	<b>Versions</b> <ul style="list-style-type: none"> <li>• For G-fuse                             <ul style="list-style-type: none"> <li>- Without LED</li> <li>- With LED 24 V AC/DC</li> <li>- With LED 48 V AC/DC</li> <li>- With LED 230 V AC/DC</li> </ul> </li> <li>• For inch fuse                             <ul style="list-style-type: none"> <li>- Without LED</li> <li>- With LED 24 V AC/DC</li> <li>- With LED, 120 V AC/110 V DC</li> </ul> </li> </ul>	<p>8WA1 011-1SF12 10 units</p> <p>8WA1 011-1SF13 10 units</p> <p>8WA1 011-1SF14 10 units</p> <p>8WA1 011-1SF15 10 units</p> <p>8WA1 011-1SF30 10 units</p> <p>8WA1 011-1SF31 10 units</p> <p>8WA1 011-1SF32 10 units</p>
<b>Accessories</b>		
 <p>8WA1 822-7EF16</p>	<b>G fuse links</b> DIN 41660	
	<b>Versions</b> <ul style="list-style-type: none"> <li>• Quick-response, high breaking capacity                             <ul style="list-style-type: none"> <li>- Rated uninterrupted current 1 A</li> <li>- Rated uninterrupted current 1.6 A</li> <li>- Rated uninterrupted current 2.5 A</li> <li>- Rated uninterrupted current 4 A</li> <li>- Rated uninterrupted current 6.3 A</li> </ul> </li> <li>• Slow-response, low breaking capacity                             <ul style="list-style-type: none"> <li>- Rated uninterrupted current 1 A</li> <li>- Rated uninterrupted current 1.6 A</li> <li>- Rated uninterrupted current 2.5 A</li> <li>- Rated uninterrupted current 4 A</li> <li>- Rated uninterrupted current 6.3 A</li> </ul> </li> </ul>	<p>8WA1 822-7EF16 10/200 units</p> <p>8WA1 822-7EF18 10 units</p> <p>8WA1 822-7EF21 10 units</p> <p>8WA1 822-7EF23 10 units</p> <p>8WA1 822-7EF25 10 units</p> <p>8WA1 822-7EF76 10 units</p> <p>8WA1 822-7EF78 10 units</p> <p>8WA1 822-7EF81 10 units</p> <p>8WA1 822-7EF83 10 units</p> <p>8WA1 822-7EF85 10 units</p>
 <p>8WA1 891</p>	<b>Bridging links</b> 5 mm × 25 mm	<p>8WA1 891 10 units</p>

\* You can order this quantity or a multiple thereof.

# 8WA1 Screw Terminals

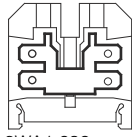
## 8WA through-type terminals with soldered and plug-in connection

### Selection and ordering data

Version	Order No.	MOQ*
<b>General details</b> <ul style="list-style-type: none"> <li>• With thermoplastic insulating body</li> <li>• Enclosed at both ends</li> </ul>		
Note	Section	Page
For labeling accessories, see ...	Accessories	10/2
<b>Terminal size 1.5 mm<sup>2</sup></b>		
 8WA1 221	<b>Through-type terminals, terminal size 1.5 mm<sup>2</sup></b> <ul style="list-style-type: none"> <li>• Beige</li> <li>• Rated uninterrupted current 18 A</li> <li>• Rated insulation voltage 380 V AC, 450 V DC with alternately arranged terminals; when using barriers up to 800 V</li> <li>• Mounting width 5.5 mm</li> <li>• Terminal height 26 mm</li> <li>• Terminal length 41 mm</li> <li>• Soldered connection at both ends</li> </ul>	<b>8WA1 221</b> 50 units
Accessories	Section	Page
• Covers		
- With lightning symbol	Accessories	9/26
- White, facility for inscription	Accessories	9/26
• Barriers, for terminal size 1.5 to 4 mm <sup>2</sup>	Accessories	9/26
		<b>8WA1 810</b> 50 units <b>8WA1 860</b> 50 units <b>8WA1 820</b> 50 units
<b>Terminal size 6 mm<sup>2</sup></b>		
 8WA1 232	<b>Through-type terminals, terminal size 6 mm<sup>2</sup>, with plug-in terminal</b> <ul style="list-style-type: none"> <li>• Beige</li> <li>• Rated uninterrupted current 16 A per clamping point</li> <li>• Rated insulation voltage 400 V, when using barriers up to 1000 V</li> <li>• Mounting width 8 mm</li> <li>• Flat connection at both ends</li> <li>• Four flat-type connections 6.3 ... 0.8 mm</li> </ul>	<b>8WA1 232</b> 50 units
 8WA1 232		
Accessories	Section	Page
• Covers		
- With lightning symbol	Accessories	9/26
- White, facility for inscription	Accessories	9/26
• Connection bars		
- For two terminals	Accessories	9/26
- For ten terminals	Accessories	9/26
• Barriers, for terminal size 6 to 16 mm <sup>2</sup>	Accessories	9/26
		<b>8WA1 811</b> 50 units <b>8WA1 862</b> 50 units <b>8WA1 822-7VH12</b> 50 units <b>8WA1 822-7VH20</b> 10 units <b>8WA1 821</b> 50 units
<b>Accessories</b>		
 8WA1 811	<b>Covers</b>	
	Versions	
	• With lightning symbol	
	- For terminal size 1 ... 2.5 mm <sup>2</sup>	<b>8WA1 810</b> 50 units
	- For terminal size 6 mm <sup>2</sup>	<b>8WA1 811</b> 50 units
	• White, facility for inscription	
	- For terminal size 1 ... 2.5 mm <sup>2</sup>	<b>8WA1 860</b> 50 units
	- For terminal size 6 mm <sup>2</sup>	<b>8WA1 862</b> 50 units
 8WA1 822-7VH12	<b>Connection bars, for through-type terminal, terminal size 6 mm<sup>2</sup>, with plug-in connection</b>	
	Versions	
	• For two terminals	<b>8WA1 822-7VH12</b> 50 units
	• For ten terminals	<b>8WA1 822-7VH20</b> 10 units
 8WA1 821	<b>Barriers</b>	
	Versions	
	• For terminal size 1.5 ... 4 mm <sup>2</sup>	<b>8WA1 820</b> 50 units
	• For terminal size 6 ... 16 mm <sup>2</sup>	<b>8WA1 821</b> 50 units

## 8WA measuring transformer terminals

### Overview

Measuring transformer terminals can be used for testing and isolating circuits in switchboards, control rooms, etc. without interrupting operation.

The isolating and instrument isolating terminals contain an isolating device in the through-type connection. The isolating device permits electrical separation between the input and output of a terminal.

Test sockets for plugs with a diameter of 4 mm can be screwed into the front side of the through-type and isolating terminals. The rated insulation voltage between colored test sockets is 125 V. The rated insulation voltage between test sockets and connection bars not connected to the terminal is 16 V (circuit 3, terminals 3 and 5).

Two adjacent terminals can be connected in parallel with the disconnecting link. The disconnecting link can be operated in any position of the isolating device.

### Instrument set for one transformer

The instrument set for one transformer makes the basic circuit of the transformer terminal blocks clear. This basic circuit is also included in much larger instrument sets, which is extended by adding on equivalent circuits. Links between the basic circuits provide many kinds of testing facilities, parallel outgoing lines to other measuring devices, connection of test equipment, etc.

### Instrument set for three transformers

The simplest version of an instrument set for a three-phase circuit consists of three basic circuits strung together without any continuing links or extensions. Instead of isolating terminals 1, 3 and 5, less expensive through-type terminals can also be used.

On the other hand, it is also possible to use instrument isolating terminals for this purpose so that the terminal versions are all the same.

### Instrument set for three transformers with neutral point

The instrument set with a neutral point is an extension of the previous circuit. Four instead of six lines are sufficient for connecting it with the measuring devices. The neutral point is produced on the measuring instruments on the one hand, and using a shortened 8WA1 822-7VH10 connection bar on the other. The instrument isolating terminal 1 is connected to the neutral point using a connecting comb.

### Note

The introduction of the 8WA1 011-1MH10 through-type terminals and their associated disconnecting links has made it considerably easier to configure terminal sets for current transformers. Instead of the 12 isolating or instrument isolating terminals used previously, now only 4 instrument isolating terminals and 3 through-type terminals are required.

### Instrument set with test facility

This instrument set represents a significant enhancement over previous types. In normal operation, terminals 2, 5 and 8 are closed. For testing a measuring instrument (e.g. a plotter), these terminals are opened and terminals 3, 6 and 9 are closed in order to feed in a test signal. The transformers first have to be short-circuited with the disconnecting links between terminals 1-2, 4-5 and 7-8. Wire jumpers connect terminals 1, 4 and 7 with the neutral point. It is formed in terminals 10, 11, 12 and 13 with an 8WA1 887 connection bar.

① Instrument set for 1 transformer

② Instrument set for 3 transformers

③ Instrument set for 3 transformers with neutral point

④ Instrument set with testing facility

Type	Number required for			
	①	②	③	④
8WA1 011-1MH10			3	7
8WA1 011-1MH11	1	3		3
8WA1 011-1MH15	1	3	4	3
8WA1 825 a)		2	2	
8WA1 885				3
8WA1 887				1
8WA1 822-7VH10			1 b)	
8WA1 822-7VH01	1	3	3	3
8WA1 822-7PH00				4
8WA1 822-7VH22			1	

a) In some cases additionally required between instrument sets



b) Shortened



Connection option for measuring transformer terminals (instrument sets)

# 8WA1 Screw Terminals

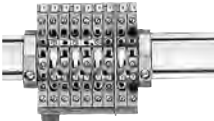
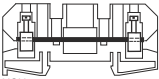
## 8WA measuring transformer terminals

### Selection and ordering data

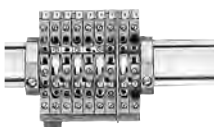
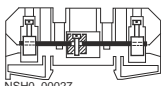
Version	Order No.	MOQ*
<b>General details</b> <ul style="list-style-type: none"> <li>• With thermoplastic insulating body</li> <li>• Screw terminals at both ends and two holes for test sockets for Ø 4 mm test plug, insulated at both ends</li> <li>• Enclosed at both ends</li> </ul>		
Note	Section	Page
For labeling accessories, see ...	Accessories	10/2
<b>Terminal size 6 mm<sup>2</sup></b>		
 <p>8WA1 011-1MH10</p>  <p>Typical circuit diagram</p>  <p>NSH0_00026 8WA1 011-1MH10</p>	<b>Through-type terminals, terminal size 6 mm<sup>2</sup></b> <ul style="list-style-type: none"> <li>• Rated uninterrupted current 41 A</li> <li>• Rated insulation voltage 500 V</li> <li>• Mounting width 8 mm</li> <li>• Terminal height 33 mm</li> <li>• Terminal length 83 mm</li> <li>• Without test sockets</li> <li>•  AWG 14-8</li> <li>•  AWG 16-10</li> </ul>	<b>8WA1 011-1MH10</b> 20 units
<b>Accessories</b> <ul style="list-style-type: none"> <li>• <b>Covers, for connection bars</b> <ul style="list-style-type: none"> <li>- Transparent <i>Accessories</i> 9/30</li> <li>- White, facility for inscription <i>Accessories</i> 9/30</li> </ul> </li> <li>• <b>Test sockets</b> <ul style="list-style-type: none"> <li>- Rated voltage between test socket and bypassed connection bar: 16 V, recessed <i>Accessories</i> 9/30</li> <li>- Rated voltage between two test sockets: 125 V                             <ul style="list-style-type: none"> <li>◦ Green <i>Accessories</i> 9/30</li> <li>◦ Black <i>Accessories</i> 9/30</li> <li>◦ Red <i>Accessories</i> 9/30</li> </ul> </li> </ul> </li> <li>• <b>Test plugs</b> <i>Accessories</i> 9/30</li> <li>• <b>Disconnecting links</b> <i>Accessories</i> 9/30</li> <li>• <b>Insulation plates, for terminal size 2.5 to 6 mm<sup>2</sup></b> <i>Accessories</i> 9/30</li> <li>• <b>Connection combs</b> <ul style="list-style-type: none"> <li>- 10-pole for measuring transformer terminals, can be shortened as required <i>Accessories</i> 9/31</li> <li>- 2-pole <i>Accessories</i> 9/31</li> </ul> </li> <li>• <b>Connection bars, for terminal size 6 mm<sup>2</sup></b> <ul style="list-style-type: none"> <li>- Two terminals <i>Accessories</i> 9/31</li> <li>- Three terminals <i>Accessories</i> 9/31</li> <li>- Four terminals <i>Accessories</i> 9/31</li> <li>- Ten terminals <i>Accessories</i> 9/31</li> <li>- Unmounted for ten terminals <i>Accessories</i> 9/31</li> </ul> </li> <li>• <b>Barriers, for Insta terminals, terminal size 2.5 mm<sup>2</sup> and measuring transformer terminals, terminal size 6 mm<sup>2</sup></b> <i>Accessories</i> 9/31</li> </ul>	<b>8WA1 822-7AX01</b> 10 units <b>8WA1 822-7AX03</b> 10 units  <b>8WA1 822-7PH00</b> 50 units  <b>8WA1 822-7PH03</b> 50 units <b>8WA1 822-7PH06</b> 50 units <b>8WA1 822-7PH08</b> 50 units <b>8WA1 868</b> 10 units <b>8WA1 822-7VH01</b> 50 units <b>8WA1 825</b> 50 units  <b>8WA7 163</b> 10 units  <b>8WA1 822-7VH22</b> 10 units  <b>8WA1 885</b> 50 units <b>8WA1 886</b> 50 units <b>8WA1 887</b> 20 units <b>8WA1 888</b> 10 units <b>8WA1 822-7VH10</b> 50 units <b>8WA1 822-7TH00</b> 50 units	

Version	Order No.	MOQ*																																																																				
 <p>8WA1 011-1MH11</p>  <p>Typical circuit diagram</p>  <p>NSH0_00027 8WA1 011-1MH11</p>	<p><b>Isolating terminals, terminal size 6 mm<sup>2</sup></b></p> <ul style="list-style-type: none"> <li>• Rated uninterrupted current 41 A</li> <li>• Rated insulation voltage 500 V</li> <li>• Mounting width 8 mm</li> <li>• Terminal height 33 mm</li> <li>• Terminal length 83 mm</li> <li>• Without test sockets</li> <li>•  AWG 14-8</li> <li>•  AWG 16-10</li> </ul>	<p><b>8WA1 011-1MH11</b></p> <p>20 units</p>																																																																				
	<table border="1"> <thead> <tr> <th>Accessories</th> <th>Section</th> <th>Page</th> </tr> </thead> <tbody> <tr> <td>• <i>Covers, for connection bars</i></td> <td></td> <td></td> </tr> <tr> <td>- Transparent</td> <td>Accessories</td> <td>9/30</td> </tr> <tr> <td>- White, facility for inscription</td> <td>Accessories</td> <td>9/30</td> </tr> <tr> <td>• <i>Test sockets</i></td> <td></td> <td></td> </tr> <tr> <td>- Rated voltage between test socket and bypassed connection bar: 16 V, recessed</td> <td>Accessories</td> <td>9/30</td> </tr> <tr> <td>- Rated voltage between two test sockets: 125 V</td> <td></td> <td></td> </tr> <tr> <td>  • Green</td> <td>Accessories</td> <td>9/30</td> </tr> <tr> <td>  • Black</td> <td>Accessories</td> <td>9/30</td> </tr> <tr> <td>  • Red</td> <td>Accessories</td> <td>9/30</td> </tr> <tr> <td>• <i>Test plugs</i></td> <td>Accessories</td> <td>9/30</td> </tr> <tr> <td>• <i>Disconnecting links</i></td> <td>Accessories</td> <td>9/30</td> </tr> <tr> <td>• <i>Insulation plates, for terminal size 2.5 to 6 mm<sup>2</sup></i></td> <td>Accessories</td> <td>9/30</td> </tr> <tr> <td>• <i>Connection combs</i></td> <td></td> <td></td> </tr> <tr> <td>- 10-pole for measuring transformer terminals, can be shortened as required</td> <td>Accessories</td> <td>9/31</td> </tr> <tr> <td>- 2-pole</td> <td>Accessories</td> <td>9/31</td> </tr> <tr> <td>• <i>Connection bars, for terminal size 6 mm<sup>2</sup></i></td> <td></td> <td></td> </tr> <tr> <td>- Two terminals</td> <td>Accessories</td> <td>9/31</td> </tr> <tr> <td>- Three terminals</td> <td>Accessories</td> <td>9/31</td> </tr> <tr> <td>- Four terminals</td> <td>Accessories</td> <td>9/31</td> </tr> <tr> <td>- Ten terminals</td> <td>Accessories</td> <td>9/31</td> </tr> <tr> <td>- Unmounted for ten terminals</td> <td>Accessories</td> <td>9/31</td> </tr> <tr> <td>• <i>Barriers, for Insta terminals, terminal size 2.5 mm<sup>2</sup> and measuring transformer terminals, terminal size 6 mm<sup>2</sup></i></td> <td>Accessories</td> <td>9/31</td> </tr> </tbody> </table>	Accessories	Section	Page	• <i>Covers, for connection bars</i>			- Transparent	Accessories	9/30	- White, facility for inscription	Accessories	9/30	• <i>Test sockets</i>			- Rated voltage between test socket and bypassed connection bar: 16 V, recessed	Accessories	9/30	- Rated voltage between two test sockets: 125 V			• Green	Accessories	9/30	• Black	Accessories	9/30	• Red	Accessories	9/30	• <i>Test plugs</i>	Accessories	9/30	• <i>Disconnecting links</i>	Accessories	9/30	• <i>Insulation plates, for terminal size 2.5 to 6 mm<sup>2</sup></i>	Accessories	9/30	• <i>Connection combs</i>			- 10-pole for measuring transformer terminals, can be shortened as required	Accessories	9/31	- 2-pole	Accessories	9/31	• <i>Connection bars, for terminal size 6 mm<sup>2</sup></i>			- Two terminals	Accessories	9/31	- Three terminals	Accessories	9/31	- Four terminals	Accessories	9/31	- Ten terminals	Accessories	9/31	- Unmounted for ten terminals	Accessories	9/31	• <i>Barriers, for Insta terminals, terminal size 2.5 mm<sup>2</sup> and measuring transformer terminals, terminal size 6 mm<sup>2</sup></i>	Accessories	9/31
Accessories	Section	Page																																																																				
• <i>Covers, for connection bars</i>																																																																						
- Transparent	Accessories	9/30																																																																				
- White, facility for inscription	Accessories	9/30																																																																				
• <i>Test sockets</i>																																																																						
- Rated voltage between test socket and bypassed connection bar: 16 V, recessed	Accessories	9/30																																																																				
- Rated voltage between two test sockets: 125 V																																																																						
• Green	Accessories	9/30																																																																				
• Black	Accessories	9/30																																																																				
• Red	Accessories	9/30																																																																				
• <i>Test plugs</i>	Accessories	9/30																																																																				
• <i>Disconnecting links</i>	Accessories	9/30																																																																				
• <i>Insulation plates, for terminal size 2.5 to 6 mm<sup>2</sup></i>	Accessories	9/30																																																																				
• <i>Connection combs</i>																																																																						
- 10-pole for measuring transformer terminals, can be shortened as required	Accessories	9/31																																																																				
- 2-pole	Accessories	9/31																																																																				
• <i>Connection bars, for terminal size 6 mm<sup>2</sup></i>																																																																						
- Two terminals	Accessories	9/31																																																																				
- Three terminals	Accessories	9/31																																																																				
- Four terminals	Accessories	9/31																																																																				
- Ten terminals	Accessories	9/31																																																																				
- Unmounted for ten terminals	Accessories	9/31																																																																				
• <i>Barriers, for Insta terminals, terminal size 2.5 mm<sup>2</sup> and measuring transformer terminals, terminal size 6 mm<sup>2</sup></i>	Accessories	9/31																																																																				

\* You can order this quantity or a multiple thereof.

# 8WA1 Screw Terminals

## 8WA measuring transformer terminals

Version	Order No.	MOQ*
---------	-----------	------



8WA1 011-1MH15

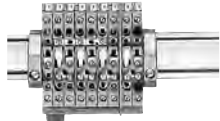

Typical circuit diagram

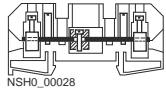

8WA1 011-1MH15

### Instrument isolating terminals, terminal size 6 mm<sup>2</sup>

- Mounting width 8 mm
- Terminal height 33 mm
- Terminal length 83 mm
- Open isolating distance
- With recessed test sockets
- AWG 14-8
- AWG 16-10

#### Accessories

- **Covers, for connection bars**
  - Transparent
  - White, facility for inscription
- **Test sockets**
  - Rated voltage between test socket and bypassed connection bar: 16 V, recessed
  - Rated voltage between two test sockets: 125 V
    - Green
    - Black
    - Red
- **Test plugs**
- **Disconnecting links**
- **Insulation plates, for terminal size 2.5 to 6 mm<sup>2</sup>**
- **Connection combs**
  - 10-pole for measuring transformer terminals, can be shortened as required
  - 2-pole
- **Connection bars, for terminal size 6 mm<sup>2</sup>**
  - Two terminals
  - Three terminals
  - Four terminals
  - Ten terminals
  - Unmounted for ten terminals
- **Barriers, for Insta terminals, terminal size 2.5 mm<sup>2</sup> and measuring transformer terminals, terminal size 6 mm<sup>2</sup>**

#### Section

#### Page

<b>8WA1 011-1MH15</b>	20 units
<b>8WA1 822-7AX01</b>	10 units
<b>8WA1 822-7AX03</b>	10 units
<b>8WA1 822-7PH00</b>	50 units
<b>8WA1 822-7PH03</b>	50 units
<b>8WA1 822-7PH06</b>	50 units
<b>8WA1 822-7PH08</b>	50 units
<b>8WA1 868</b>	10 units
<b>8WA1 822-7VH01</b>	50 units
<b>8WA1 825</b>	50 units
<b>8WA7 163</b>	10 units
<b>8WA1 822-7VH22</b>	10 units
<b>8WA1 885</b>	50 units
<b>8WA1 886</b>	50 units
<b>8WA1 887</b>	20 units
<b>8WA1 888</b>	10 units
<b>8WA1 822-7VH10</b>	50 units
<b>8WA1 822-7TH00</b>	50 units

### Accessories

#### Covers, for connection bars

For through-type terminals, size 2.5 to 6 mm<sup>2</sup>

#### Versions

- Transparent
- White, facility for inscription

<b>8WA1 822-7AX01</b>	10 units
<b>8WA1 822-7AX03</b>	10 units

#### Test sockets

Ø 4 mm

#### Versions

- Rated voltage between test socket and bypassed connection bar: 16 V, recessed
- Rated voltage between two test sockets: 125 V
  - Green
  - Black
  - Red

<b>8WA1 822-7PH00</b>	50 units
<b>8WA1 822-7PH03</b>	50 units
<b>8WA1 822-7PH06</b>	50 units
<b>8WA1 822-7PH08</b>	50 units



8WA1 822-7PH00



8WA1 822-7PH03

#### Test plugs

Red

<b>8WA1 868</b>	10 units
-----------------	----------



8WA1 868

#### Disconnecting links

Rated insulation voltage with disconnecting link open according to DIN VDE 0110: 125 V Gr. C or 250 V Gr. B

<b>8WA1 822-7VH01</b>	50 units
-----------------------	----------



8WA1 822-7VH01



#### Insulation plates, for terminal size 2.5 to 6 mm<sup>2</sup>

<b>8WA1 825</b>	50 units
-----------------	----------



8WA1 825

## 8WA measuring transformer terminals

	Version	Order No.	MOQ*
 8WA7 163	<b>Connection combs</b> For inserting in the clamping points Versions <ul style="list-style-type: none"> <li>• 10-pole for measuring transformer terminals, can be shortened as required</li> <li>• 2-pole</li> </ul>	<b>8WA7 163</b>  <b>8WA1 822-7VH22</b>	10 units  10 units
 8WA1 885	<b>Connection bars, for terminal size 6 mm<sup>2</sup></b> Versions <ul style="list-style-type: none"> <li>• Two terminals</li> <li>• Three terminals</li> <li>• Four terminals</li> <li>• Ten terminals</li> <li>• Unmounted for ten terminals</li> </ul>	<b>8WA1 885</b> <b>8WA1 886</b> <b>8WA1 887</b> <b>8WA1 888</b> <b>8WA1 822-7VH10</b>	50 units 50 units 20 units 10 units 50 units
 8WA1 822-7TH00	<b>Barriers, for Insta terminals, terminal size 2.5 mm<sup>2</sup> and measuring transformer terminals, terminal size 6 mm<sup>2</sup></b>	<b>8WA1 822-7TH00</b>	50 units

\* You can order this quantity or a multiple thereof.

# 8WA1 Screw Terminals

## 8WA transformer terminals

### Overview

The 8WA9 200 terminals are used for transformers and rectifiers.



The terminals are insulated at both ends and are finger-safe to DIN VDE 0106 Part 100.

The normal labeling accessories can be used to label the transformer terminals.

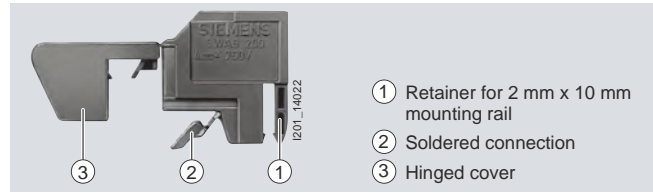
In addition to the screw connection, the 8WA9 terminals have a 6.3-0.8 flat connector. The soldered connection is protected by a hinged cover following soldering on of the conductor.



### Selection and ordering data

Version	Order No.	MOQ*						
<b>Terminal size 4 mm<sup>2</sup></b>								
 <p>8WA9 200 (side view)</p>  <p>8WA9 200 (plan view)</p>	<p><b>Transformer terminals, terminal size 4 mm<sup>2</sup></b></p> <ul style="list-style-type: none"> <li>Enclosed at both ends</li> <li>Beige</li> <li>Rated uninterrupted current 24 A</li> <li>Rated insulation voltage acc. to DIN VDE 0110, Group C 690 V, 600 V to Ⓢ, 600 V to Ⓢ Group D</li> <li>Mounting width 7.5 mm</li> <li>Terminal height 34 mm</li> <li>Terminal length 27 mm</li> <li>With insulating body</li> <li>Made of molded thermoplastic</li> <li>For 2 mm × 10 mm mounting rail</li> <li>Screw terminal:                             <ul style="list-style-type: none"> <li>Solid 0.5 mm<sup>2</sup> up to 6 mm<sup>2</sup></li> <li>Finely stranded with or without end sleeve 0.5 mm<sup>2</sup> to 4 mm<sup>2</sup></li> <li>Stripped length 10 mm</li> </ul> </li> <li>Flat connector: 6.3-0.8</li> <li>Soldered connection:                             <ul style="list-style-type: none"> <li>Solid up to Ø 3 mm</li> <li>Finely stranded up to 2.5 mm<sup>2</sup></li> <li>Stripped length 7 mm</li> <li>Ⓢ18-10 AWG, Ⓢ18-10 AWG</li> </ul> </li> </ul>	<p><b>8WA9 200</b></p> <p>100 units</p>						
<p><b>Accessories</b></p> <ul style="list-style-type: none"> <li>Labeling strips                             <ul style="list-style-type: none"> <li>Blank</li> <li>Any inscription</li> </ul> </li> </ul>	<table border="1"> <thead> <tr> <th>Section</th> <th>Page</th> </tr> </thead> <tbody> <tr> <td>Accessories</td> <td>9/32</td> </tr> <tr> <td>Accessories</td> <td>9/32</td> </tr> </tbody> </table>	Section	Page	Accessories	9/32	Accessories	9/32	<p><b>8WA8 848-2AY</b></p> <p><b>8WA8 847-OXA</b></p> <p>100 units 100 units</p>
Section	Page							
Accessories	9/32							
Accessories	9/32							
<p><b>Accessories</b></p> <p><b>Labeling strips</b></p> <p><b>Versions</b></p> <ul style="list-style-type: none"> <li>Blank</li> <li>Any inscription</li> </ul>		<p><b>8WA8 848-2AY</b></p> <p><b>8WA8 847-OXA</b></p> <p>100 units 100 units</p>						

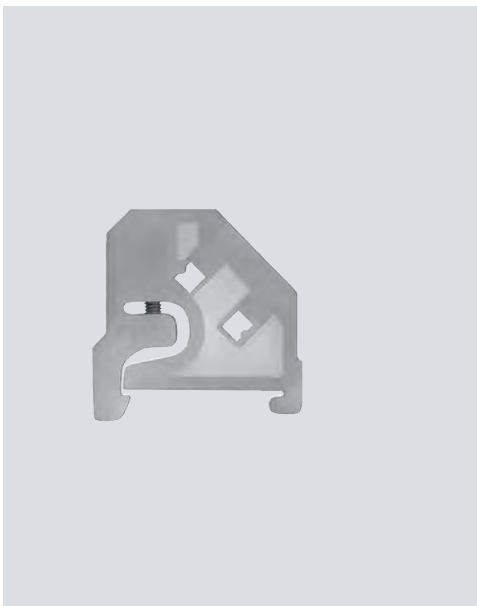

10/2	<b>Accessories for labeling system</b>
10/3	<b>Standard labeling system</b>
10/5	<b>Mounting accessories</b>

**More technical product information:**

Service&Support Portal:  
[www.support.automation.siemens.com](http://www.support.automation.siemens.com)

Product List:  
Technical specifications

Entry List:  
Updates / Downloads / FAQ /  
Manuals / Operating instructions /  
Characteristic curves / Certificates

# Accessories for 8WA Terminal Blocks

## Accessories for labeling system

### Selection and ordering data

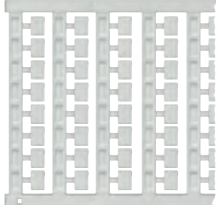

#### Accessories for ALPHA FIX PRINT printer labeling systems

Version	Order No.	MOQ*
 <p><b>Fluid cartridges, for ALPHA FIX PRINT printers</b> Black</p> <p>8WH9 060-6BA08</p>	<b>8WH9 060-6BA08</b>	1 unit
 <p><b>Labels, for labeling 8WA terminal blocks using the ALPHA FIX PRINT printer</b> 5 x 7 mm</p> <p>8WH8 202-2DA05</p>	<b>8WH8 202-2DA05</b>	560 units

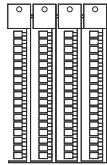
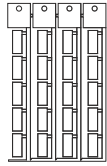
#### Accessories for plotter labeling system

Version	Order No.	MOQ*
 <p><b>Labels, for plotter inscription</b> 1 frame = 68 labels</p> <p>NSFH0_00037</p> <p>8WA8 850-2AY</p>	<p><b>8WA8 850-2AY</b> <b>8WA8 851-2AY</b></p> <hr/> <p><b>8WA8 854-2AY</b></p>	<p>1020 units 1020 units</p> <hr/> <p>1260 units</p>
 <p><b>Device labels</b> • 1 frame = 20 labels • 20 x 9 • White</p> <p>NSFH0_00038</p> <p>3TX4 210-0R</p>	<b>3TX4 210-0R</b>	380 units

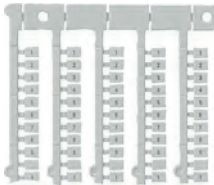



### Selection and ordering data

	Version	Order No.	MOQ*
	<b>Labels, for manual inscription</b> <ul style="list-style-type: none"> <li>• Not suitable for plotting</li> <li>• Blank</li> </ul>		
	<b>Versions</b> <ul style="list-style-type: none"> <li>• Label size 5 mm × 7 mm</li> <li>• Label size 5 mm × 10 mm</li> </ul>	<b>8WA8 848-2AY</b> <b>8WA8 800-2AY</b>	100 units 100 units
	<b>Note</b> These labels are not suitable for printing with the ALPHA FIX PRINT printer or plotter.		
	<b>Labels, type 860/861</b> <ul style="list-style-type: none"> <li>• Label size 5 mm × 7 mm</li> <li>• Font height 2 mm</li> <li>• Grid size: 6.2 mm</li> </ul>		
	<b>Versions</b> <ul style="list-style-type: none"> <li>• Horizontal inscription</li> <li>• Vertical inscription</li> </ul>	<b>8WA8 860-□□□</b> <b>8WA8 861-□□□</b>	200 units 200 units
	<b>Inscription</b> <ul style="list-style-type: none"> <li>• 1...5 (40x)</li> <li>• 6...10 (40x)</li> <li>• 11...15 (40x)</li> <li>• 16...20 (40x)</li> <li>• 21...25 (40x)</li> <li>• 26...30 (40x)</li> <li>• 31...35 (40x)</li> <li>• 36...40 (40x)</li> <li>• 41...45 (40x)</li> <li>• 46...50 (40x)</li> <li>• 51...55 (40x)</li> <li>• 56...60 (40x)</li> <li>• 61...65 (40x)</li> <li>• 66...70 (40x)</li> <li>• 71...75 (40x)</li> <li>• 76...80 (40x)</li> <li>• 81...85 (40x)</li> <li>• 86...90 (40x)</li> <li>• 91...95 (40x)</li> <li>• 96...100 (40x)</li> <li>• 1...20 (10x)</li> <li>• 1...40 (5x)</li> <li>• 41...100 (3x)</li> <li>• 101...200 (2x)</li> <li>• 201...300 (2x)</li> <li>• 1...9, blank (20x)</li> <li>• 1...100 (2x)</li> <li>• A, B...T (10x)</li> <li>• U, V, W, X, Y, Z (30x) +, - (10x)</li> <li>• L1, L2, L3, N, PE (40x)</li> <li>• U1, V1, W1, U2, V2, W2, (30x); blank (20x)</li> </ul>	▲▲▲ <b>0BA</b> <b>0BB</b> <b>0BC</b> <b>0BD</b> <b>0BE</b> <b>0BF</b> <b>0BG</b> <b>0BH</b> <b>0BJ</b> <b>0BK</b> <b>0BL</b> <b>0BM</b> <b>0BN</b> <b>0BP</b> <b>0BQ</b> <b>0BR</b> <b>0BS</b> <b>0BT</b> <b>0BU</b> <b>0BV</b> <b>0AB</b> <b>0AC</b> <b>0AD</b> <b>0AF</b> <b>0AG</b> <b>0AA</b> <b>0AE</b> <b>1AA</b> <b>1AB</b> <b>1AC</b> <b>1AD</b>	
 Horizontal inscription (8WA8 860-0AA)			
 Vertical inscription (8WA8 861-0AA)			
	<b>Labels, yellow, with lightning symbol</b>	<b>8WA8 861-0CF</b>	200 units



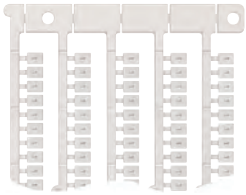



\* You can order this quantity or a multiple thereof.

# Accessories for 8WA Terminal Blocks

## Standard labeling systems

	Version	Order No.	MOQ*
 <p>Horizontal inscription (8WA8 847-0AA)</p>  <p>Vertical inscription (8WA8 848-0AA)</p>	<b>Labels, type 847/848</b> <ul style="list-style-type: none"> <li>Label size 5 mm × 7 mm</li> <li>Font height 2 mm</li> <li>Grid size: 6.2 mm</li> </ul>		
	<b>Labels, type 847/848</b> <ul style="list-style-type: none"> <li>Label size 5 mm × 7 mm</li> <li>Font height 2 mm</li> <li>Grid size: 6.2 mm</li> </ul>		
	<b>Versions</b> <ul style="list-style-type: none"> <li>Horizontal inscription</li> <li>Vertical inscription</li> </ul>	<b>8WA8 847-□□□</b> <b>8WA8 848-□□□</b>	100 units 100 units
	<b>Inscription</b> <ul style="list-style-type: none"> <li>L1 (100x)</li> <li>L2 (100x)</li> <li>L3 (100x)</li> </ul>	▲▲▲	
	<ul style="list-style-type: none"> <li>2AC</li> <li>2AD</li> <li>2AE</li> </ul>		
	<ul style="list-style-type: none"> <li>N (100x)</li> <li>MP (100x)</li> <li>PE (100x)</li> </ul>	<b>1AR</b> <b>2AB</b> <b>2AH</b>	
	<ul style="list-style-type: none"> <li>L+ (100x)</li> <li>L- (100x)</li> </ul>	<b>2AF</b> <b>2AG</b>	
	<ul style="list-style-type: none"> <li>Blue (100x) - <i>Note: Only as 8WA8 848</i></li> <li>Ground symbol (100x)</li> </ul>	<b>2BC</b> <b>2AA</b>	
	<ul style="list-style-type: none"> <li>N (100x)</li> <li>X (100x)</li> <li>Y (100x)</li> </ul>	<b>1AR</b> <b>1AG</b> <b>1AH</b>	
	 <p>8WA1 806</p>	<b>Labels, custom inscriptions</b> <ul style="list-style-type: none"> <li>Label size 5 mm × 7 mm</li> <li>Font height 2 mm</li> <li>Grid size: 6.2 mm</li> <li>Specify required inscription in plain text</li> </ul>	
<b>Labels, custom inscriptions</b> <ul style="list-style-type: none"> <li>Label size 5 mm × 7 mm</li> <li>Font height 2 mm</li> <li>Grid size: 6.2 mm</li> <li>Specify required inscription in plain text</li> </ul>			
	<b>Versions</b> <ul style="list-style-type: none"> <li>Horizontal inscription</li> <li>Vertical inscription</li> </ul>	<b>8WA8 847-0XA</b> <b>8WA8 848-0XA</b>	100 units 100 units
 <p>8WA8 846-2AY</p>	<b>End labeling plates</b> <ul style="list-style-type: none"> <li>21 × 42 mm</li> <li>Paper label, inscription possible, with transparent cover</li> <li>Suitable for 8WA1 805, 8WA1 808 and 8WA2 808 end retainers</li> </ul>	<b>8WA1 806</b>	50 units
 <p>8WA8 826-0AA</p>	<b>Labels, for cables</b>	<b>8WA8 846-2AY</b>	1000 units
 <p>8WA8 826-0AA</p>	<b>Terminal strip labels</b> <ul style="list-style-type: none"> <li>Suitable for 8WA1 808 and 8WA2 808 end retainers</li> </ul>		
	<b>Terminal strip labels</b> <ul style="list-style-type: none"> <li>Suitable for 8WA1 808 and 8WA2 808 end retainers</li> </ul>		
	<b>Versions</b> <ul style="list-style-type: none"> <li>Printed with "X1"</li> <li>Printed with "X2"</li> <li>Printed with "X3"</li> <li>Blank</li> </ul>	<b>8WA8 826-0AA</b> <b>8WA8 826-0AB</b> <b>8WA8 826-0AC</b> <b>3TX4 210-0H</b>	100 units 100 units 100 units 100 units

### Selection and ordering data

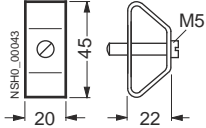
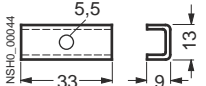
	Version	Order No.	MOQ*
	<b>End retainers, with screw fixing</b> <ul style="list-style-type: none"> <li>Mounting width 10 mm</li> <li>Suitable for 8WA1 806 end labeling plate or 8WA8 826-0A terminal strip identification label or 3TX4 210-0H device label or four 8WA8 8 . labels.</li> </ul>	<b>8WA1 808</b>	50 units
	<b>End retainers, steel</b> <ul style="list-style-type: none"> <li>Mounting width 10.3 mm</li> <li>Suitable for 8WA1 806 end labeling plates</li> </ul> <p>Note</p> <p>An 8WA1 820 barrier must be inserted if using end retainers against an 8WA1 89. connection bar (size 2.5).</p>	<b>8WA1 805</b>	50 units
	<b>Standard mounting rails</b> <p>Versions</p> <ul style="list-style-type: none"> <li>With holes                             <ul style="list-style-type: none"> <li>EN 50 022-35 x 7.5</li> <li>2 m long, 1 mm thick</li> <li>Steel, sendzimir-galvanized</li> </ul> </li> <li>Non-perforated                             <ul style="list-style-type: none"> <li>Non-perforated, copper                                     <ul style="list-style-type: none"> <li>EN 50022-35 x 15</li> <li>2 m long, 2.3 mm thick</li> </ul> </li> <li>Non-perforated, steel, galvanized, chromated                                     <ul style="list-style-type: none"> <li>Similar to EN 50022-35 x 15</li> <li>2 m long, 1.5 mm thick</li> </ul> </li> </ul> </li> </ul>	<b>5ST1 145</b>  <b>5ST1 141</b> <b>8WA7 551</b>  <b>5ST1 142</b>	20 units  20 units 1 unit  10 units
	<b>Test plugs</b> <ul style="list-style-type: none"> <li>For 8WA1 and 8WA2 terminals with 2.3 mm ø hole or 8WA1 854, 8WA1 884 test sockets</li> <li>Uninterrupted current 10 A</li> </ul> <p>Versions</p> <ul style="list-style-type: none"> <li>Red</li> <li>Blue</li> </ul>	<b>8WA1 868</b> <b>8WA1 870</b>	10 units 10 units
	<b>Test sockets</b> <ul style="list-style-type: none"> <li>ø 2.3 mm</li> <li>With matching spacer sleeve for connection bars, terminal sizes 2.5 and 4 mm², two-tier terminals, rear level, terminal size 6 mm²</li> <li>Uninterrupted current 10 A</li> </ul> <p>Versions</p> <ul style="list-style-type: none"> <li>Test sockets</li> <li>Spacer sleeves</li> </ul> <p>Note</p> <p>The test socket must be used with a spacer sleeve.</p>	<b>8WA1 884</b> <b>8WA1 822-7VH11</b>	100 units 100 units
	<b>Reduction plugs</b> <ul style="list-style-type: none"> <li>For 8WA1 and 8WA2 terminals with 2.3 mm ø hole or 8WA1 854, 8WA1 884 test sockets</li> <li>Uninterrupted current 10 A</li> <li>With 4 mm Ø hole</li> </ul>	<b>8WA1 871</b>	10 units
	<b>Spacer brackets</b> For raised mounting of terminal strips	<b>8WA7 53</b>	50 units
	<b>Spacers</b> <ul style="list-style-type: none"> <li>With 5.5 mm hole</li> <li>For raised mounting of terminal strips</li> </ul>	<b>8WA7 52</b>	100 units

\* You can order this quantity or a multiple thereof.

# Accessories for 8WA Terminal Blocks

## Mounting accessories

	Version	Order No.	MOQ*
	<p><b>Mounting brackets</b> For support rails</p>	<p><b>8WA7 46</b></p>	<p>10 units</p>
	<p><b>Insulation carriers</b> For insulated mounting of support rails onto plates, frame profiles and standard mounting rails EN 50022-35</p>	<p><b>8WA1 857</b></p>	<p>20 units</p>
	<p><b>Screwdrivers, for 8WA2</b></p> <ul style="list-style-type: none"> <li>• 3.5 mm × 0.5 mm, partially insulated</li> <li>• Green</li> <li>• Approx. 175 mm long</li> </ul>	<p><b>8WA2 880</b></p>	<p>1 unit</p>

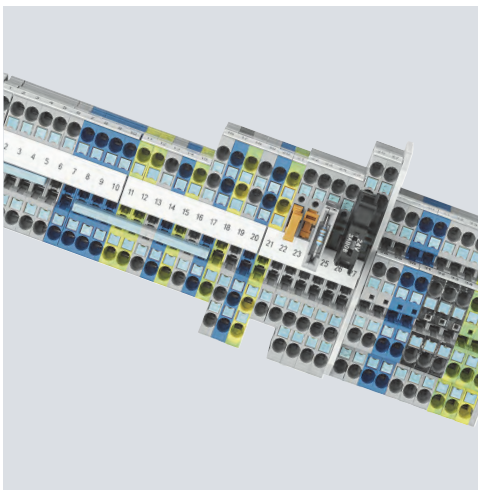

11/2	<b>Catalog notes</b>
11/3	<b>Further documentation</b>
11/4	<b>Standards and approvals</b>
11/9	<b>Comprehensive support from A to Z</b>
11/10	<b>Subject index</b>
11/12	<b>Order No. index incl. export markings</b>
11/15	<b>Conditions of sale and delivery</b>

## Catalog notes

### Overview

#### **Trademarks**

All product designations may be registered trademarks or product names of Siemens AG or supplier companies whose use by third parties for their own purposes may violate the rights of the owner.

#### **Amendments**

All technical data, dimensions and weights are subject to change without notice unless otherwise specified on the pages of this catalog.

#### **Dimensions**

All dimensions are in mm.

#### **Images**

The illustrations are not binding.

#### **Technical data**

The technical data in the catalog are for general information. The instruction manuals and the operating instructions on the products must be observed during assembly, operation and maintenance.

Further technical information is available at [www.support.automation.siemens.com](http://www.support.automation.siemens.com)

- under Product List:
  - Technical specifications
- under Entry List:
  - Updates
  - Downloads
  - FAQ
  - Manuals
  - Operating instructions
  - Characteristic curves
  - Certificates

Configurators can be found at [www.siemens.com/lowvoltage/configurators](http://www.siemens.com/lowvoltage/configurators)

#### **Assembly, operation and maintenance**

The instruction manuals and the operating instructions on the products must be observed during assembly, operation and maintenance.

## Overview

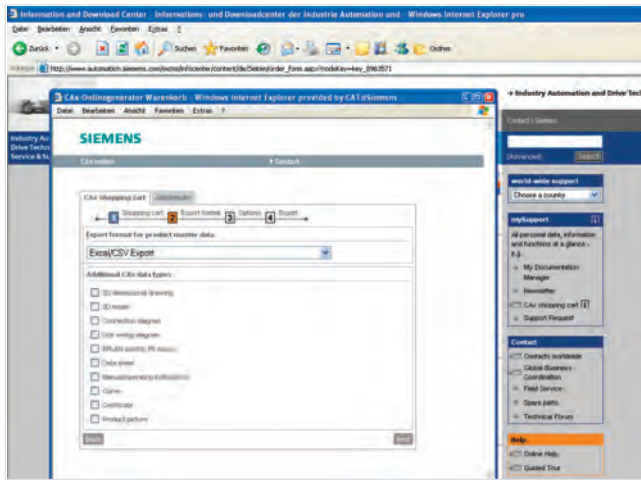

For your configuration systems we can provide technical and graphic data in electronic form for the range of low-voltage power distribution and electrical installation products:

### CAx online generator

For the further processing of low-voltage power distribution and electrical installation products in CAE/CAD systems the online generator provides:

- Technical product master data in CSV and Excel format
- Graphic product data
  - 2D dimensional drawings in DXF format (other formats optional)
  - 3D models in STEP format
  - Internal circuit diagrams
  - EPLAN electric P 8 macros
- Documentation in the form of PDF files
  - Product data sheets
  - Manuals
  - Operating instructions
  - Characteristic curves
  - Certificates
- Product photos
- Texts for tenders in GAEB and Text format.

[www.siemens.com/cax](http://www.siemens.com/cax)

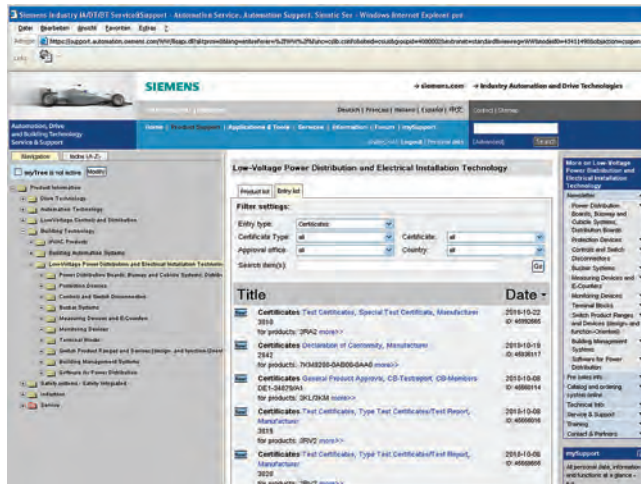

### Certificates

Information on the certificates available (CE, UL, CSA, FM, shipping authorizations) for low-voltage power distribution and electrical installation products can be found on the Internet at:

[www.support.automation.siemens.com](http://www.support.automation.siemens.com)

In the Entry List you can use the certificate type (general product approval, explosion protection, test certificates, shipbuilding,...) as a filter criterion.

## Standards and approvals

### 811Overview

#### Approvals, test certificates, characteristic curves

An overview of the certificates available for low-voltage power distribution and electrical installation products along with more technical documentation can be consulted daily on the Internet at:

[www.support.automation.siemens.com](http://www.support.automation.siemens.com)

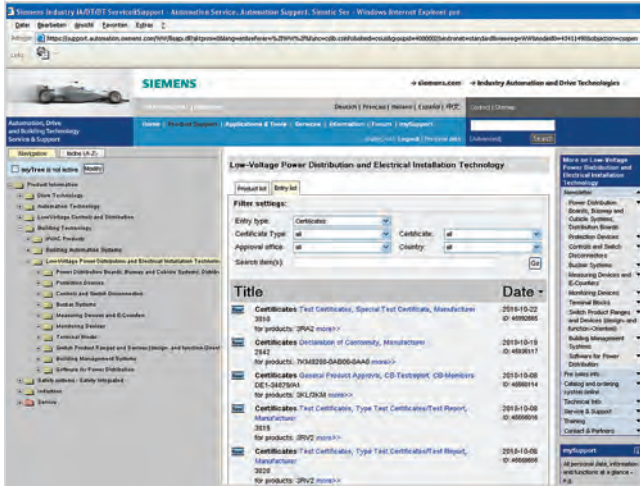

Product support: Approvals / Certificates

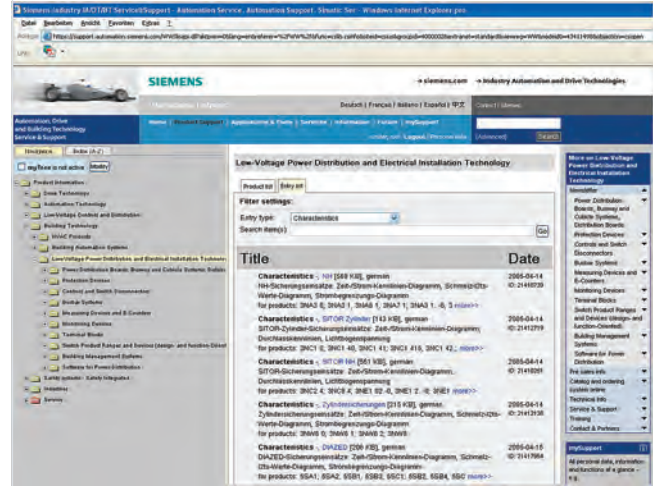

Product support: Characteristic curves

#### Product standards (excerpt)

IEC	EN	DIN VDE	Title
60947-1	60947-1	--	Low-voltage controlgear and switchgear: General requirements
60947-2	60947-2	--	• Circuit breakers
60947-3	60947-3	--	• Load-break switches, disconnectors, switch disconnectors and fuse-combination units
60947-4-1	60947-4-1	--	• Contactors and motor starters: Electromechanical contactors and motor starters
60947-4-2	60947-4-2	--	• Contactors and motor starters: Semiconductor motor controllers and starters, soft starters
60947-4-3	60947-4-3	--	• AC semiconductor controllers and contactors for non-motor loads
60947-5-1	60947-5-1	--	• Control devices and switching elements: Electromechanical control circuit devices
60947-5-2	60947-5-2	--	• Control devices and switching elements: Proximity switches
60947-5-3	60947-5-3	--	• Proximity switches (specific behavior under fault conditions)
60947-5-5	60947-5-5	--	• EMERGENCY-STOP devices with mechanical latching
60947-5-6	60947-5-6	--	• Control devices and switching elements - DC interface for proximity switches and switching amplifier (NAMUR)
60947-5-7	60947-5-7	--	• Requirements for proximity switches with analog output
60947-5-8	60947-5-8	--	• Approval switches
60947-5-9	60947-5-9	--	• Flow sensors
60947-6-1	60947-6-1	--	• Multifunctional switching device: Transfer switches
60947-6-2	60947-6-2	--	• Multifunctional switching device: Control and protection switching device (CPS)
60947-7-1	60947-7-1	--	• Ancillary equipment: Terminal blocks for copper conductors
60947-7-2	60947-7-2	--	• Ancillary equipment: Protective conductor for copper conductors
60947-7-3	60947-7-3	--	• Ancillary equipment: Safety requirements for terminal blocks
60947-8	60947-8	--	• Releases for the integrated thermal Protection (PTC) of rotating electric machines
62026-2	50295	--	Low-voltage controlgear and switchgear: Actuator-Sensor Interface (AS-I)
60269-1	60269-1	--	Low-voltage fuses: General requirements
60269-4	60269-4	--	Low-voltage fuses: Supplementary requirements for fuse links for protecting semiconductor components
60050-441	--	--	International dictionary/switchgear and/or switching devices and fuses
60439-1	60439-1	--	Low-voltage switchgear assemblies: Type-tested and partially type-tested assemblies
60439-3	60439-3	--	Low-voltage switchgear assemblies – distribution boards
61439-1	61439-1	0660-600-1	Low-voltage switchgear assemblies – General part
61439-2	61439-2	0660-600-2	Low-voltage switchgear assemblies – Power switchgear assemblies
--	50274	--	Low-voltage switchgear assemblies - Protection from electric shock - Protection from accidental touching of dangerous active parts
61140	61140	--	Protection from electric shock - General requirements for apparatus and equipment
60664-1	60664-1	--	Insulation coordination for electrical equipment in low-voltage systems; Principles, requirements and tests

IEC	EN	DIN VDE	Title
60204-1	60204-1	--	Electrical equipment of machines: General requirements
--	50178	--	Equipment of electrical power installations with electronic equipment
60079-14	60079-14	--	Electrical apparatus for potentially explosive gas atmospheres Installing electrical apparatus in potentially explosive gas atmospheres (except mining)
60079-2	60079-2	--	Electrical equipment for potentially explosive gas atmospheres - Part 2 Pressurized enclosures M "p"
61810-1	61810-1	--	Electromechanical elementary relays (electromechanical switching relays without a fixed time response); General and safety-related requirements
61812-1	61812-1	--	Relays with a fixed time response (timing relays) for industrial applications - Part 1: Requirements and tests
60999-1	60999-1	--	Connecting materials - Safety requirements for screw terminals and screwless clamping points for electrical copper conductors - Part 1: General requirements and special requirements for clamping points for conductors from 0.2 mm <sup>2</sup> to 35 mm <sup>2</sup>
61000-4-1	61000-4-1	--	Electromagnetic compatibility (EMC) - Part 4: Testing and measuring techniques; Main Section 1: Overview of measuring techniques for interference immunity; Basic EMC standard
61000-6-3	61000-6-3	--	Electromagnetic compatibility (EMC); Basic specification for emitted interference in residential and commercial environments as well as in light industry
61000-6-4	61000-6-4	--	Electromagnetic compatibility (EMC); Basic specification for emitted interference in industrial environments
60044-1	60044-1	--	Measuring transducers: Current transformers

UL	CSA C22.2	ASME	JIS	Title
508	--	--	--	Industrial control equipment
489	--	--	--	Molded case circuit breakers, molded case switches and circuit breaker enclosures
1012	--	--	--	Power units other than CLASS 2
1561	--	--	--	Dry-type general purpose and power transformers
60601-1	--	--	--	Medical electrical equipment, Part 1: General requirements for safety (IEC 60601, EN 60601, VDE 0750-1)
1604	--	--	--	Electrical equipment for use in CLASS I and II, Division 2 and CLASS III hazardous (Classified) locations
1059	--	--	--	Terminal blocks
486A-486B	--	--	--	Wire connectors
486E	--	--	--	Equipment wiring terminals for use with aluminum and/or copper conductors
50	--	--	--	Enclosures for electrical equipment. Non-environmental considerations
--	No. 66	--	--	Specialty transformers
--	No. 14	--	--	Industrial control equipment
--	No. 5	--	--	Molded case circuit breakers, molded case switches and circuit breaker enclosures
--	No. 107-1	--	--	General use power supplies
--	--	A17.5 / B 44.1	--	Elevator and escalator electrical equipment
--	--	--	C 8201-4-1	Low-voltage switchgear and controlgear; Contactors and motor-starters

### Approval requirements valid in different countries

Siemens low-voltage switchgear and controlgear are designed, manufactured and tested according to the relevant German standards (DIN and VDE), IEC publications and European standards (EN) as well as CSA and UL standards. The standards assigned to the single devices are stated in the relevant parts of this catalog.

As far as is economically viable, in addition to the pertinent VDE, EN and IEC standards, the requirements of the various regulations valid in other countries are also taken into account in the design of the equipment.

In some countries (see table below), an approval is required for certain low-voltage switchgear and controlgear components. Depending on the market requirements, these devices have been submitted for approval to the authorized testing institutes.

In some cases, CSA for Canada and UL for the USA only approve special switchgear versions. Such special versions are listed separately from the standard versions in the individual parts of this catalog.



For this equipment, partial limitations of the maximum permissible voltages, currents and rated outputs can be imposed, or special approval and, in some cases, special identification is required.

For use on board ship, the specifications of the marine classification societies must be observed (see table below). In some cases, they require type tests of the components to be approved.

The present state of approval is shown in the "Type overview of approved devices" tables on page 11/7.

## Standards and approvals

### Testing bodies, approval identification and approval requirements

	Canada <sup>1)</sup>	USA <sup>1)</sup>	China
Government-appointed or private, officially recognized testing bodies	CSA UL (USA)	UL	CQC
Approval symbol			
Approval requirements	+	+	+
Remarks	UL and CSA are authorized to grant approvals according to Canadian or US regulations. Please note: These approvals are frequently not recognized and additional approval often has to be obtained from the national testing authority.		CCC

<sup>1)</sup> For guide numbers and file numbers for the approvals, visit our website at [www.support.automation.siemens.com](http://www.support.automation.siemens.com)

### Marine classification societies

	Germany	United Kingdom	France	Norway	CIS	Italy	Poland	USA
Name	Germanischer Lloyd	Lloyds Register of Shipping	Bureau Veritas	Det Norske Veritas	Russian Maritime Register of Shipping	Registro Italiano Navale	Polski Rejestr Statków	American Bureau of Shipping
Codes	GL	LRS	BV	DNV	RMRS	RINA	PRS	ABS

### CE marking

Manufacturers of products which fall within the scope of EC directives must identify their products, operating instructions or packaging with a CE mark.

The CE mark confirms that a product fulfills the appropriate basic requirements of all pertinent directives. The mark is a mandatory requirement for putting products into circulation throughout the EC.

All the products in this catalog are in conformance with the EC directives and bear the CE mark.

- Low-voltage directive
- EMC directive
- Machinery directive
- Ex protection directive

The CE mark of conformity: 

### USA and Canada Standards

In the USA and Canada, for machine tools and processing machines in particular, supply lines are laid using rubber insulated cable enclosed in heavy-duty steel piping similar to that used for gas or water pipe systems.











The tubing system must be completely watertight and electrically conductive (especially sleeving and elbows). Since the tubing system can also be grounded, the cable entries of enclosed units equipped with heavy-gauge or metric threads must be fitted with metal adapters between these threads and the tube thread. The necessary adapters are specified for the switchgear as accessories; they should be ordered separately unless otherwise specified.

Low-voltage switchgear and controlgear for auxiliary circuits (e.g. contactor relays, commanding and signaling devices and auxiliary switches/auxiliary contacts in general) are generally only approved by CSA and UL for "**Heavy Duty**" or "**Standard Duty**" and are identified either with these specifications in addition to the maximum permissible voltage or by using an abbreviation.

The abbreviations are harmonized with IEC 60947-5-1 Appendix 1 Table A.1 and correspond to the stated utilization categories.

For various switching devices detailed in the catalog, a note has been included to the effect that, above a certain voltage, the auxiliary switches/auxiliary contacts can only be used if they have the same polarity. This means that the input terminals can only be connected to the same pole of the control voltage, e.g. "600 V AC above 300 V AC same polarity".

### Different features of UL approvals (for USA and Canada)

Recognized Component	Listed Product
Devices are identified on the rating plate using the "UL recognition mark": USA:  ,  Canada:  , 	Devices are identified using the "UL listing mark" on the rating plate e. g. USA:  LISTED 165 C Canada:  LISTED 165 C IND. CONT. EQ. IND. CONT. EQ. (165 C stands for: Siemens, I IA CD Division, Amberg plant)
Devices are approved as modules for "factory wiring", i. e.: as devices for installation in control systems, which are selected, installed, wired and tested entirely by trained personnel in factories, workshops or elsewhere, <b>according to the operating conditions</b> .	Devices are approved for "field wiring", i. e.: • As devices for installation in control systems, which are completely wired by trained personnel in factories, workshops or elsewhere. • As single devices for sale in retail outlets in the USA/Canada.
If devices are  or  approved as "listed products", they are also approved as  or  "recognized components".	

For more information about UL and CSA see 11/5.

### Type overview of approved devices

#### 8WA and 8WH screw terminals

Type	Approvals										Marine classifications							
	Canada 1) 2)		USA 1)		China 3)	Czech Repub- lic	Slova- kia	Pol- land	Hungary	Germany	United Kingdom	France	Norway	CIS	Italy	Poland	USA	
	Ⓢ	cⓈUS	Ⓢ	cⓈUS	Ⓢ	CCC	EZU	SKTC	SEP	MEEI	GL	LRS	BV	DNV	RMRS	RINA	PRS	ABS
<b>Terminal blocks<sup>4)</sup></b>																		
8WA1 010-1PH01	+	--	--	--	--	--	--	+	--	--	+	--	--	--	--	--	+	--
8WA1 010-1PQ00	+	--	--	--	--	--	--	--	--	--	--	--	--	--	--	--	--	--
8WA1 011-0D	+	--	--	--	+	--	+	+	--	+	+	+	+	--	--	+	+	
8WA1 011-1BF21	+	--	--	--	+	--	+	+	--	+	+	+	+	--	--	+	+	
8WA1 011-1BF22	+	--	--	--	+	--	+	+	--	+	+	+	+	--	--	+	+	
8WA1 011-1BF23	+	--	--	--	+	--	+	+	--	+	+	+	+	--	--	+	+	
8WA1 011-1BF24	+	--	--	--	+	--	--	--	--	+	+	+	+	--	--	--	+	
8WA1 011-1BF25	+	--	--	--	+	--	--	--	--	--	--	--	--	--	--	--	--	
8WA1 011-1BG11	+	--	--	--	+	--	+	+	--	+	+	+	+	--	--	+	+	
8WA1 011-1BG21	+	--	--	--	+	--	+	+	--	+	+	+	+	--	--	+	+	
8WA1 011-1BG22	+	--	--	--	+	--	+	+	--	+	+	+	+	--	--	+	+	
8WA1 011-1BG24	+	--	--	--	+	--	--	--	--	+	+	+	+	--	--	--	+	
8WA1 011-1BH23	+	--	--	--	+	--	+	+	--	+	+	+	+	--	--	--	+	
8WA1 011-1BH24	+	--	--	--	+	--	--	--	--	+	+	+	+	--	--	--	+	
8WA1 011-1BK11	+	--	--	--	+	--	+	+	--	+	+	+	+	--	--	+	+	
8WA1 011-1BM11	+	--	--	--	+	--	+	+	--	+	+	+	+	--	--	+	+	
8WA1 011-1BP11	--	--	--	--	--	--	+	+	--	+	+	+	+	--	--	+	+	
8WA1 011-1DF11	+	--	--	--	+	--	+	+	--	+	+	+	+	--	--	+	+	
8WA1 011-1DG11	+	--	--	--	+	--	+	+	--	+	+	+	+	--	--	+	+	
8WA1 011-1DH11	+	--	--	--	+	--	+	+	--	+	+	+	+	--	--	+	+	
8WA1 011-1EF20	--	--	--	--	--	--	+	+	--	+	--	--	--	--	--	+	--	
8WA1 011-1MH1.	+ <sup>5)</sup>	--	--	--	+	--	+	+	--	+	+	+	+	--	--	+	+	
8WA1 011-1EF28	--	--	--	--	--	--	--	--	--	+	--	--	--	--	--	--	--	
8WA1 011-1NF01	+	--	--	--	+	--	+	+	--	+	+	+	+	--	--	+	+	
8WA1 011-1NF02	+	--	--	--	+	--	--	--	--	+	+	+	+	--	--	+	+	
8WA1 011-1NG31	+	--	--	--	+	--	--	--	--	+	+	+	+	--	--	+	+	
8WA1 011-1NG32	+	--	--	--	+	--	--	--	--	+	+	+	+	--	--	+	+	

+ Standard version approved.

-- Not yet submitted for approval.

1) For guide numbers and file numbers for approvals, please visit [www.support.automation.siemens.com](http://www.support.automation.siemens.com) and select "Product Support".

2) cⓈ and cⓈUS approvals are available in accordance with US approval.

3) Not required for terminal blocks.

4) For Ⓢ and Ⓢ nominal data of the terminal blocks, please refer to the [Technical Specifications](#).

5) 600 A, 5 A, Type D or 300 V, Type C.

Further certifications and approvals available on request.

## Standards and approvals

Type	Approvals							Marine classifications								
	Canada 1) 2)	USA 1)	USA 1)	Czech Repub- lic	Slovakia	Poland	Hungary	Germany	United Kingdom	France	Norway	CIS	Italy	Poland	USA	
	☉	®	UL	EZU	SKTC	SEP	MEEI	GL	LRS	BV	DNV	RMRS	RINA	PRS	ABS	
<b>Reihenklammen<sup>3)</sup></b>																
8WA1 011-1NH01	+	--	+	+	+	--	+	+	+	+	+	--	--	+	+	
8WA1 011-1NH02	+	--	+	--	--	--	--	+	+	+	+	--	--	+	+	
8WA1 011-1NK02	--	--	+	--	+	--	--	+	+	+	+	--	--	+	+	
8WA1 011-1PF00	+	--	+	+	+	--	+	+	+	+	+	--	--	+	+	
8WA1 011-1PF01	+	--	+	+	+	--	+	+	+	+	+	--	--	+	+	
8WA1 011-1PF11	+	--	+	+	+	--	+	+	+	+	+	--	--	+	+	
8WA1 011-1PG00	+	--	+	+	+	--	+	+	+	+	+	--	--	+	+	
8WA1 011-1PG01	+	--	+	+	+	--	+	+	+	+	+	--	--	+	+	
8WA1 011-1PG11	+	--	+	+	+	--	+	+	+	+	+	--	--	+	+	
8WA1 011-1PH00	+	--	+	+	+	--	+	+	+	+	+	--	--	+	+	
8WA1 011-1PH11	+	--	+	+	+	--	+	+	+	+	+	--	--	+	+	
8WA1 011-1PK00	+	--	+	--	+	--	+	+	+	+	+	--	--	+	+	
8WA1 011-1PM00	+	--	+	--	--	--	+	+	+	+	+	--	--	+	+	
8WA1 011-1SF12	+	--	+	+	+	--	+	+	+	+	+	--	--	+	+	
8WA1 011-1SF2.	+	--	+	--	+	--	--	--	--	--	--	--	--	+	--	
8WA1 011-2BG11	+	--	+	+	--	--	--	+	+	+	+	--	--	+	+	
8WA1 011-2DG11	+	--	+	+	+	--	+	+	+	+	+	--	--	+	+	
8WA1 011-2SF2.	+	--	+	--	+	--	--	--	--	--	--	--	--	+	--	
8WA1 011-3D.21	+	--	+	+	+	--	+	+	+	+	+	--	--	+	+	
8WA1 011-3JF16 bis	+	--	+	+	+	--	+	--	--	--	--	--	--	--	--	
8WA1 011-3JF20	+	--	+	+	+	--	+	--	--	--	--	--	--	--	--	
8WA1 011-6BG11	+	--	+	+	--	--	--	+	+	+	+	--	--	+	+	
8WA1 011-6DG11	+	--	+	+	+	--	+	+	+	+	+	--	--	+	+	
8WA1 011-6EG..	--	--	+	+	+	--	+	--	--	--	--	--	--	+	--	
8WA1 012-1DK10	--	--	+	--	--	--	--	--	--	--	--	--	--	--	--	
8WA1 012-1D.14	+	--	+	--	--	--	--	--	--	--	--	--	--	--	--	
8WA1 204 bis	+	--	+	+	+	--	+	+	+	+	+	--	--	+	+	
8WA1 206	+	--	+	+	+	--	+	+	+	+	+	--	--	+	+	
8WA1 211	--	--	--	--	+	--	--	--	--	--	--	--	--	+	--	
8WA1 221	--	--	--	--	+	--	--	--	--	--	--	--	--	+	--	
8WA1 232	--	--	+	--	+	--	--	--	--	--	--	--	--	+	--	
8WA1 304	+	--	+	+	+	--	+	+	+	+	+	--	--	+	+	
8WA1 305	+	--	+	+	+	--	+	+	+	+	+	--	--	+	+	
8WA1 501	+	--	+	--	--	--	--	--	--	--	--	--	--	--	--	
8WA1 604	--	--	+	+	+	--	+	+	+	+	+	--	--	+	+	
8WA2 011-3KE..	+	--	+	--	--	--	--	--	--	--	--	--	--	--	--	
8WH	<a href="http://www.support.automation.siemens.com">www.support.automation.siemens.com</a>															

+ Standard version approved.

-- Not yet submitted for approval.

1) For guide numbers and file numbers for approvals, please visit [www.support.automation.siemens.com](http://www.support.automation.siemens.com) and select "Product Support".

2) c® and cUL approvals are available in accordance with US approval.

3) For ☉ and UL nominal data of the terminal blocks, please refer to the [Technical specifications](#).

Further certifications and approvals available on request.

### More information

You can find more information about standards and approvals at [www.support.automation.siemens.com](http://www.support.automation.siemens.com)

If you have any questions concerning UL/CSA approvals, contact Technical Support, Tel.: +49 (911) 8957222.

**Overview**

Product information	
<b>Website</b>	Fast, targeted information on low-voltage power distribution: <a href="http://www.support.automation.siemens.com">www.support.automation.siemens.com</a>
Product information/product & system selection	
<b>Industry Mall</b>	Comprehensive information and order platform for the Siemens Industry Basket: <a href="http://www.siemens.com/lowvoltage/mall">www.siemens.com/lowvoltage/mall</a>
Product documentation	
<b>Service &amp; Support portal</b>	Comprehensive technical information - from planning to configuration and operation: <a href="http://www.siemens.com/lowvoltage/support">www.siemens.com/lowvoltage/support</a>
<b>CAX Data</b>	Collation of commercial and technical master product data: <a href="http://www.siemens.com/cax">www.siemens.com/cax</a>
<b>Image database</b>	Collection of product photographs and graphics, such as dimensional drawings and internal circuit diagrams: <a href="http://www.siemens.com/lowvoltage/bilddb">www.siemens.com/lowvoltage/bilddb</a>
Product hotline	
<b>Technical Support</b>	Support for all technical queries about our products: Call: <a href="tel:1866-663-7324">1866-663-7324</a> On the web: <a href="http://www.support.automation.siemens.com">www.support.automation.siemens.com</a>

## Subject index

### Overview

#### A

Accessories	
• 8WA	10/2
• 8WH	8/2
Adapters	
• For inscription of 8WA labels	8/2
ALPHA FIX PRINT	
• Printer labeling system	8/2, 10/2
ALPHA FIX Terminal Blocks	
• Spring-loaded terminals	1/2
ALPHA FIX terminal blocks	
• Accessories 8WA	10/2
• Accessories 8WH	8/2
• Combination plug-in terminals 8WH	5/2
• Combination plug-in terminals 8WH5	5/2
• Insulation displacement terminals 8WH3	6/2
• IPo installation terminals 8WH	3/2
• IPo installation terminals 8WH6	3/2
• IPo plug-in terminals 8WH	2/2
• IPo plug-in terminals 8WH6	2/2
• Screw terminals 8WA	9/2
• Screw terminals 8WA1	9/2
• Screw terminals 8WH1	7/2
• Spring-loaded terminals 8WH	4/2, 4/3
• Spring-loaded terminals 8WH2	4/2

#### B

Barriers	9/14, 9/18, 9/20, 9/23, 9/26, 9/31
Blank labels	9/18
Branch terminals 8WA	9/15
Bridging links	9/25

#### C

Combination plug-in terminals 8WH	5/2
Combs	7/23
Connecting combs	8/9
Connection bars	9/14, 9/18, 9/20, 9/26, 9/31
Connection combs	9/31
Cover segments	2/6, 4/17, 4/24, 4/26, 4/38, 5/6, 6/8, 6/12
Covers	2/6, 2/7, 2/14, 3/5, 3/9, 3/14, 4/17, 4/20, 4/24, 4/26, 4/32, 4/36, 4/38, 4/40, 5/6, 5/7, 6/8, 6/10, 6/12
• For connection bars	9/16, 9/30
• For screw terminals	3/7, 3/11
• for screw terminals	3/11
• For terminal size 2.5 mm <sup>2</sup>	2/10, 2/12
• For terminal size 4 mm <sup>2</sup>	2/8, 2/10, 2/12, 2/14
• For three-tier terminals	4/34

#### D

Device labels	9/18, 10/2
Diode terminal 8WH	4/37
Diode terminals	9/21
Diode terminals 8WA	9/23
Diode terminals 8WH	7/17
Disconnecting links	9/14, 9/20, 9/30

#### E

End labeling plates	10/4
End plates	9/20, 9/22
End retainers	
• Steel	10/5
• Thermoplast	9/13, 9/18
• With screw fixing	10/5

#### F

Feeder terminals	
• For N-busbars	3/9, 3/14, 8/10, 9/16, 9/18
Fluid cartridges for ALPHA FIX PRINT printers	8/2, 10/2
Four-tier motor terminals 8WH	4/35
Fuse terminals 8WA	9/25
Fuse terminals 8WH	4/21, 7/8

#### G

G fuse links	9/25
--------------	------

#### H

High-current PE terminals 8WH	7/20
High-current terminals 8WH	7/20
Hybrid through-type terminals 8WH	4/18
Hybrid through-type terminals with IPo connection 8WH5	5/7

#### I

Insertion profiles	7/23
Insta terminal	9/17
Installation terminals 8WH	3/12
Instrument isolating terminals	9/30
Insulation carriers	10/6
• For mounting insulated support rails	9/18
Insulation displacement terminals 8WH3	6/2
Insulation plates	9/14, 9/20, 9/30
IPo plug-in terminals 8WH	2/2
Isolating blade terminal	2/9
Isolating blade terminals 8WH	4/23, 7/10
Isolating terminal	9/29
Isolating terminal 8WH	4/25, 6/11, 7/11
Isolating terminals 8WA	9/23
Isolating terminals 8WH6	2/11

#### J

Jumpers	9/13, 9/20
---------	------------

#### L

Label holders	9/16
• For three-tier terminals	4/34
Labeling strips	9/32
Labeling system	
• Printer ~	8/2, 10/2
• Standard ~	8/3, 10/3
Labels	
• Custom inscriptions	10/4
• Flat	8/3, 8/4, 8/5, 8/6, 8/7
• For cables	10/4
• For manual inscription	10/3
• For plotter inscription	8/2, 10/2
• Front	8/3, 8/4, 8/5, 8/6, 8/7
• Type 847/848	10/4
• Type 860/861	10/3
• Yellow, with lightning symbol	10/3
Labels for labeling	
• Terminal blocks using the ALPHA FIX PRINT printer 8WA	10/2
• Terminal blocks using the ALPHA FIX PRINT printer 8WH	8/2
Latches	5/10

**M**

Measuring transformer terminals 8WA .....	9/27
Modular test plugs .....	8/8
Mounting accessories 8WA .....	10/5
Mounting accessories 8WH .....	8/8
Mounting brackets .....	10/6

**N**

N-busbars .....	3/9, 3/11, 3/14, 7/27, 8/10
• 6 × 6 mm .....	9/16, 9/18
N-conductor isolating 8WH	
• Screw terminals .....	3/10
N-conductor isolating terminals .....	9/15
N-conductor isolating terminals 8WH .....	3/8

**P**

PE hybrid through-type terminals 8WH .....	4/18
PE plugs	
• Without slot for comb .....	5/10
PE plugs 8WH9 .....	5/8
PE through-type terminals 8WH5 .....	5/5
PE two-tier terminals 8WH .....	4/27, 4/32, 6/9
Permanent links .....	7/23
Plug-in zone connectors	
• For isolating terminals .....	8/10
Plugs	
• For components .....	9/24
• Without slot for comb .....	5/10
Plugs 8WH9 .....	5/8
Printer labeling system	
• ALPHA FIX PRINT .....	8/2, 10/2

**Q**

• Quick-fit end retainers .....	8/8
---------------------------------	-----

**R**

Reducing combs .....	8/8
Reduction plugs .....	10/5

**S**

Screw terminals 8WA1 .....	9/2
Screw terminals 8WH1 .....	7/2
Screwdrivers .....	8/9
• For 8WA2 .....	10/6
Shield terminals 8WH .....	7/24
Spacer brackets .....	10/5
Spacer plates .....	8/8
Spacers .....	10/5
Spring-loaded terminals .....	1/2
• 8WH .....	4/3
Spring-loaded terminals 8WH .....	4/2
Standard labeling system .....	8/3
Standard labeling systems .....	10/3
Standard mounting rails .....	10/5
Standards and approvals .....	11/4 to 11/8
Support brackets .....	3/5, 3/9, 3/14, 7/27

**T**

Tap-off terminals .....	7/23
Terminal	
• For components .....	9/24
• With red LED .....	9/22
Terminal strip labels .....	10/4
Terminal strip markers	
• For end retainers .....	8/8
Terminal strips .....	9/14
Terminals .....	3/11
Test adapters .....	8/8
Test plugs .....	9/14, 9/23, 9/30, 10/5
Test sockets .....	9/14, 9/20, 9/30, 10/5
Three-tier terminal 8WA .....	9/17

**Through-type**

• Screw PE terminals .....	3/6
Through-type 8WH	
• Screw terminals .....	3/6
Through-type PE terminals .....	4/7 ... 4/17
Through-type PE terminals 8WA .....	9/9 ... 9/13
Through-type PE terminals 8WH .....	5/7, 6/5
Through-type terminals .....	3/4, 9/28
• With sectionalizing feature .....	9/23
Through-type terminals 8WA .....	9/9
• With soldered and plug-in connection .....	9/26
Through-type terminals 8WH .....	3/4, 4/7, 5/7, 6/5, 7/4
Through-type terminals 8WH5 .....	5/5
Through-type terminals 8WH6 .....	2/4
Transformer terminals 8WA .....	9/32
Two-tier diode terminals 8WH .....	4/39, 7/18
Two-tier terminals	
• With electronic components 8WA .....	9/21
Two-tier terminals 8WA .....	9/19
Two-tier terminals 8WH .....	4/27, 6/9, 7/12
• With isolating blade .....	7/15
• With isolating function .....	7/15
Two-tier terminals 8WH6 .....	2/13

**W**

Warning covers .....	4/17
----------------------	------

**Z**

Zener diode terminals .....	9/22
-----------------------------	------

## Order number index incl. export markings

### Overview

Order No.	Page	Export markings	
		ECCN	AL
<b>3T</b>			
3TX4 210-0H	9/18	N	N
3TX4 210-0	9/15 ... 16, 9/18, 10/2, 10/4	N	N
<b>5S</b>			
5ST	10/5	N	N
<b>8G</b>			
8GF	9/15 ... 16, 9/18	N	N
<b>8WA</b>			
8WA1	9/9 ... 26, 9/28 ... 31, 10/4 ... 6	N	N
8WA1 010	7/22, 9/11	N	N
8WA1 011-0	9/9 ... 10	N	N
8WA1 011-1BF	9/9	N	N
8WA1 011-1BG	9/10	N	N
8WA1 011-1BH	9/11	N	N
8WA1 011-1BK	9/12	N	N
8WA1 011-1BM	9/12	N	N
8WA1 011-1BP	9/13	N	N
8WA1 011-1D	9/9 ... 11	N	N
8WA1 011-1E	9/23 ... 24	N	N
8WA1 011-1M	9/28 ... 30	N	N
8WA1 011-1N	9/15 ... 16	N	N
8WA1 011-1PF	9/9	N	N
8WA1 011-1PG	9/10	N	N
8WA1 011-1PH	9/11	N	N
8WA1 011-1PK	9/12	N	N
8WA1 011-1PM	9/13	N	N
8WA1 011-1S	9/25	N	N
8WA1 011-2	9/19	N	N
8WA1 011-3D	9/9 ... 11	N	N
8WA1 011-3J	9/17	N	N
8WA1 011-6	9/19	N	N
8WA1 011-6E	9/21 ... 22	N	N
8WA1 20	9/12 ... 13	N	N
8WA1 21	9/13 ... 14	N	N
8WA1 22	9/26	N	N
8WA1 23	9/26	N	N
8WA1 3	9/12	N	N
8WA2 84	3/9, 3/11, 3/14, 7/27, 8/10	N	N
8WA2 86	3/9, 3/14, 8/10, 9/15 ... 16, 9/18	N	N
8WA2 868	3/9, 3/14, 8/10, 9/16, 9/18	N	N
8WA2 87	3/9, 3/14, 8/10, 9/16, 9/18	N	N
8WA2 88	10/6	N	N
8WA7	9/29 ... 31, 10/6	N	N
8WA7 1	9/28	N	N
8WA7 52	10/5	N	N
8WA7 53	10/5	N	N
8WA7 55	10/5	N	N
8WA8 80	10/3	N	N
8WA8 82	10/4	N	N
8WA8 846	10/4	N	N

Order No.	Page	Export markings	
		ECCN	AL
8WA8 847	9/32, 10/4	N	N
8WA8 848-	10/4	N	N
8WA8 848-0	10/4	N	N
8WA8 848-2	9/18, 9/32, 10/3	N	N
8WA8 85	10/2	N	N
8WA8 86	10/3	N	N
8WA9	9/32	N	N
<b>8WH</b>			
8WH1 000-0AF	7/5	N	N
8WH1 000-0AG	7/5	N	N
8WH1 000-0AH	7/5	N	N
8WH1 000-0AJ	7/6	N	N
8WH1 000-0AK	7/6	N	N
8WH1 000-0AM	7/7	N	N
8WH1 000-0AN	7/22	N	N
8WH1 000-0AQ	7/22	N	N
8WH1 000-0AS	7/23	N	N
8WH1 000-0AU	7/23	N	N
8WH1 000-0CF	7/5	N	N
8WH1 000-0CG	7/5	N	N
8WH1 000-0CH	7/6	N	N
8WH1 000-0CJ	7/6	N	N
8WH1 000-0CK	7/6	N	N
8WH1 000-0CM	7/7	N	N
8WH1 000-0CN	7/22	N	N
8WH1 000-0CQ	7/22	N	N
8WH1 000-1	7/9	N	N
8WH1 000-6	7/10 ... 11, 7/17	N	N
8WH1 001	3/7, 3/11	N	N
8WH1 001-0A	3/6 ... 7	N	N
8WH1 020-0	7/13 ... 14	N	N
8WH1 020-5	7/19	N	N
8WH1 020-6	7/16	N	N
8WH1 025	7/13 ... 14	N	N
8WH2	4/19 ... 20	N	N
8WH2 000-0AE	4/10	N	N
8WH2 000-0AF	4/11	N	N
8WH2 000-0AG	4/13	N	N
8WH2 000-0AH	4/15	N	N
8WH2 000-0AJ	4/15	N	N
8WH2 000-0AK	4/16	N	N
8WH2 000-0AM	4/17	N	N
8WH2 000-0CE	4/10	N	N
8WH2 000-0CF	4/12	N	N
8WH2 000-0CG	4/14	N	N
8WH2 000-0CH	4/15	N	N
8WH2 000-0CJ	4/16	N	N
8WH2 000-0CK	4/16	N	N
8WH2 000-0CM	4/17	N	N
8WH2 000-1	4/22	N	N

Order number index  
incl. export markings

Order No.	Page	Export markings	
		ECCN	AL
8WH2 000-6	4/24, 4/26	N	N
8WH2 003-0AE	4/10	N	N
8WH2 003-0AF	4/11	N	N
8WH2 003-0AG	4/13	N	N
8WH2 003-0AH	4/15	N	N
8WH2 003-0CE	4/10	N	N
8WH2 003-0CF	4/12	N	N
8WH2 003-0CG	4/14	N	N
8WH2 003-0CH	4/15	N	N
8WH2 003-5	4/38	N	N
8WH2 003-6	4/24, 4/26	N	N
8WH2 004-0A	4/10 ... 11, 4/13	N	N
8WH2 004-0C	4/10, 4/12, 4/14	N	N
8WH2 004-6	4/24, 4/26	N	N
8WH2 020-0A	4/29 ... 30, 4/32	N	N
8WH2 020-0C	4/29, 4/31 ... 32	N	N
8WH2 020-4	4/30 ... 31	N	N
8WH2 020-5	4/39 ... 40	N	N
8WH2 022	4/30	N	N
8WH2 023	4/30 ... 31	N	N
8WH2 025	4/29 ... 30, 4/32	N	N
8WH2 03	4/33 ... 34	N	N
8WH2 04	4/36	N	N
8WH2 1	4/19	N	N
8WH3 000-0	6/6 ... 7	N	N
8WH3 000-6	6/11 ... 12	N	N
8WH3 003	6/6 ... 7	N	N
8WH3 004	6/6	N	N
8WH3 02	6/10	N	N
8WH5	5/6 ... 7	N	N
8WH6	2/6 ... 8, 2/10, 2/12, 2/14, 3/4 ... 5, 3/9, 3/13	N	N
8WH8	8/2 ... 7, 10/2	N	N
8WH9	8/9	N	N
8WH9 000-0A	6/8, 6/12	N	N
8WH9 000-0G	2/6, 4/17, 4/24, 4/26, 4/38	N	N
8WH9 000-1A	6/8	N	N
8WH9 000-1GA	2/6, 4/17, 5/6 ... 7	N	N
8WH9 000-1GD	4/34	N	N
8WH9 000-1GE	4/36	N	N
8WH9 000-1L	5/6	N	N
8WH9 000-1P	7/6 ... 7	N	N
8WH9 000-1Q	7/14, 7/16, 7/19	N	N
8WH9 000-1S	3/9	N	N
8WH9 000-1V	4/32, 4/40	N	N
8WH9 000-1W	3/5	N	N
8WH9 000-2A	6/8, 6/12	N	N
8WH9 000-2G	2/6, 4/17, 4/24, 4/26	N	N
8WH9 000-2H	4/20	N	N
8WH9 000-2P	7/17	N	N
8WH9 000-2V	4/32	N	N
8WH9 000-3	3/14	N	N

Order No.	Page	Export markings	
		ECCN	AL
8WH9 000-3SC	2/10, 2/12	N	N
8WH9 000-3SD	2/10, 2/12	N	N
8WH9 000-4G	2/6, 4/17, 4/24, 4/26, 4/38	N	N
8WH9 000-4N	5/6	N	N
8WH9 000-4S	2/14	N	N
8WH9 000-5	2/10, 2/12, 4/24, 4/26	N	N
8WH9 000-6	3/14	N	N
8WH9 001	6/8	N	N
8WH9 001-0	6/8, 6/12	N	N
8WH9 001-1	6/8, 6/10	N	N
8WH9 001-2	6/8, 6/12	N	N
8WH9 002	7/7, 7/9	N	N
8WH9 003-0	4/17	N	N
8WH9 003-1G	2/7 ... 8, 2/10, 2/12, 4/17	N	N
8WH9 003-1S	3/9	N	N
8WH9 003-1V	2/14, 4/32	N	N
8WH9 003-2	2/7, 4/17, 4/20	N	N
8WH9 003-4	2/7, 4/17	N	N
8WH9 003-7	3/5	N	N
8WH9 004	3/5, 3/9, 4/17	N	N
8WH9 005	4/17	N	N
8WH9 005-3	3/7, 3/11	N	N
8WH9 006	4/17	N	N
8WH9 01	8/8	N	N
8WH9 020-0	8/8	N	N
8WH9 020-3	7/22 ... 23	N	N
8WH9 020-6	7/23, 8/9	N	N
8WH9 020-8	8/10	N	N
8WH9 03	3/7	N	N
8WH9 04	8/10	N	N
8WH9 040-1	5/9 ... 10	N	N
8WH9 05	5/10	N	N
8WH9 060-4	8/2	N	N
8WH9 060-4B	4/33 ... 34	N	N
8WH9 060-5	4/17, 7/7	N	N
8WH9 060-6	8/2, 10/2	N	N
8WH9 061	4/17	N	N
8WH9 063-5A	4/17	N	N
8WH9 063-5B	7/7, 7/10, 7/17	N	N
8WH9 064	4/17	N	N
8WH9 064-5B	7/6 ... 7	N	N
8WH9 065	4/17, 7/7	N	N
8WH9 066	4/17, 7/7	N	N
8WH9 067	4/17, 7/7	N	N
8WH9 070-0A	2/6 ... 7, 2/10, 2/12, 4/17, 4/22, 4/24, 4/26, 5/6	N	N
8WH9 070-0B	2/14, 4/32, 4/40	N	N
8WH9 070-0D	4/17	N	N
8WH9 070-0G	2/6 ... 7, 2/12, 4/17, 4/24, 4/26, 4/38	N	N
8WH9 070-0H	2/6 ... 7, 4/17, 4/24, 4/26, 5/6 ... 7	N	N
8WH9 070-0J	6/8	N	N

# Appendix

## Order number index incl. export markings

Order No.	Page	Export markings	
		ECCN	AL
8WH9 070-OK	4/22, 6/8, 6/12	N	N
8WH9 070-OL	6/8	N	N
8WH9 070-OM	6/10	N	N
8WH9 070-6B	7/6 ... 7	N	N
8WH9 070-6F	7/14, 7/16, 7/19	N	N
8WH9 070-6G	3/7	N	N
8WH9 070-6H	3/7	N	N
8WH9 076	7/7	N	N
8WH9 12	3/11	N	N
8WH9 120	5/10, 7/23	N	N
8WH9 13	7/25 ... 26	N	N
8WH9 140	7/27	N	N
8WH9 141	3/11	N	N
8WH9 142	3/14	N	N
8WH9 143	3/5, 3/9	N	N
8WH9 15	8/8	N	N
8WH9 16	7/14, 7/16, 7/19	N	N
8WH9 2	8/9	N	N

1. **WARRANTY** - (a) Seller warrants that on the date of shipment the goods are of the kind and quality described herein and are free of non-conformities in workmanship and material. This warranty does not apply to goods delivered by Seller but manufactured by others.

(b) Buyer's exclusive remedy for a nonconformity in any item of the goods shall be the repair or the replacement (at Seller's option) of the item and any affected part of the goods. Seller's obligation to repair or replace shall be in effect for a period of one (1) year from initial operation of the goods but not more than eighteen (18) months from Seller's shipment of the goods, provided Buyer has sent written notice within that period of time to Seller that the goods do not conform to the above warranty. Repaired and replacement parts shall be warranted for the remainder of the original period of notification set forth above, but in no event less than 12 months from repair or replacement. At its expense, Buyer shall remove and ship to Seller any such nonconforming items and shall reinstall the repaired or replaced parts. Buyer shall grant Seller access to the goods at all reasonable times in order for Seller to determine any nonconformity in the goods. Seller shall have the right of disposal of items replaced by it. If Seller is unable or unwilling to repair or replace, or if repair or replacement does not remedy the nonconformity, Seller and Buyer shall negotiate an equitable adjustment in the contract price, which may include a full refund of the contract price for the nonconforming goods.

(c) SELLER HEREBY DISCLAIMS ALL OTHER WARRANTIES, EXPRESS OR IMPLIED, EXCEPT THAT OF TITLE. SPECIFICALLY, IT DISCLAIMS THE IMPLIED WARRANTIES OF MERCHANTABILITY, FITNESS FOR A PARTICULAR PURPOSE, COURSE OF DEALING AND USAGE OF TRADE.

(d) Buyer and successors of Buyer are limited to the remedies specified in this article and shall have no others for a nonconformity in the goods. Buyer agrees that these remedies provide Buyer and its successors with a minimum adequate remedy and are their exclusive remedies, whether Buyer's or its successors' remedies are based on contract, warranty, tort (including negligence), strict liability, indemnity, or any other legal theory, and whether arising out of warranties, representations, instructions, installations, or non-conformities from any cause.

(e) Note: This article 1 does not apply to any software which may be furnished by Seller. In such cases, the attached Software License Addendum applies.

2. **PATENTS** - Seller shall pay costs and damages finally awarded in any suit against Buyer or its vendees to the extent based upon a finding that the design or construction of the goods as furnished infringes a United States patent (except infringement occurring as a result of incorporating a design or modification at Buyer's request), provided that Buyer promptly notifies Seller of any charge of infringement, and Seller is given the right at its expense to settle such charge and to defend or control the defense of any suit based upon such charge. Seller shall have no obligation hereunder with respect to claims, suits or proceedings, resulting from or related to, in whole or in part, (i) the use of software or software documentation, (ii) compliance with Buyer's specifications, (iii) the combination with, or modification of, the goods after delivery by Seller, or (iv) the use of the goods, or any part thereof, in the practice of a process. THIS ARTICLE SETS FORTH SELLER'S ENTIRE LIABILITY WITH RESPECT TO PATENTS.

3. **PERFORMANCE; DELAYS** - Timely performance by Seller is contingent upon Buyer's supplying to Seller, when needed, all required technical information and data, including drawing approvals, and all required commercial documentation. If Seller suffers delay in performance due to any cause beyond its reasonable control, the time of performance shall be extended a period of time equal to the period of the delay and its consequences. Seller will give to Buyer notice within a reasonable time after Seller becomes aware of any such delay.

4. **SHIPMENT, TITLE AND RISK OF LOSS** - Unless the delivery terms of this contract expressly provide for F.O.B. destination, shipping/delivery will be F.O.B. Seller's point of shipment with title to the goods and risk of loss or damage passing to Buyer at that point. Buyer will be responsible for shipment during transit and for filing any damage or loss claims directly with the carrier. Seller may make partial shipments.

5. **TAXES** - Any applicable duties or sales, use, excise, value-added or similar taxes will be added to the price and invoiced separately (unless an acceptable exemption certificate is furnished).

6. **TERMS OF PAYMENT** - (a) Unless otherwise stated, all payments shall be in United States dollars, and a pro rata payment shall become due as each shipment is made. If shipment is delayed by Buyer, date of notice of readiness for shipment shall be deemed to be date of shipment for payment purposes.

(b) On late payments, the contract price shall, without prejudice to Seller's right to immediate payment, be increased by 1 1/2% per month on the unpaid balance, but not to exceed the maximum permitted by law.

(c) If any time in Seller's judgment Buyer is unable or unwilling to meet the terms specified, Seller may require satisfactory assurance or full or partial payment as a

condition to commencing or continuing manufacture or making shipment, and may, if shipment has been made, recover the goods from the carrier, pending receipt of such assurances.

7. **NONCANCELLATION** - Buyer may not cancel or terminate for convenience, or direct suspension of manufacture, except with Seller's written consent and then only upon terms that will compensate Seller for its engineering, fabrication and purchasing charges and any other costs relating to such cancellation, termination or suspension, plus a reasonable amount for profit.

8. **NUCLEAR** - Buyer represents and warrants that the goods covered by this contract shall not be used in or in connection with a nuclear facility or application. If Buyer is unable to make such representation and warranty, then Buyer agrees to indemnify and hold harmless Seller and to waive and require its insurers to waive all right of recovery against Seller for any damage, loss, destruction, injury or death resulting from a "nuclear incident", as that term is defined in the Atomic Energy Act of 1954, as amended, whether or not due to Seller's negligence.

9. **LIMITATION OF LIABILITY** - NEITHER SELLER, NOR ITS SUPPLIERS SHALL BE LIABLE, WHETHER IN CONTRACT, WARRANTY, FAILURE OF A REMEDY TO ACHIEVE ITS INTENDED OR ESSENTIAL PURPOSES, TORT (INCLUDING NEGLIGENCE), STRICT LIABILITY, INDEMNITY OR ANY OTHER LEGAL THEORY, FOR LOSS OF USE, REVENUE OR PROFIT, OR FOR COSTS OF CAPITAL OR OF SUBSTITUTE USE OR PERFORMANCE, OR FOR INDIRECT, SPECIAL, LIQUIDATED, INCIDENTAL OR CONSEQUENTIAL DAMAGES, OR FOR ANY OTHER LOSS OR COST OF A SIMILAR TYPE, OR FOR CLAIMS BY BUYER FOR DAMAGES OF BUYER'S CUSTOMERS. SELLER'S MAXIMUM LIABILITY UNDER THIS CONTRACT SHALL BE THE CONTRACT PRICE. BUYER AND SELLER AGREE THAT THE EXCLUSIONS AND LIMITATIONS SET FORTH IN THIS ARTICLE ARE SEPARATE AND INDEPENDENT FROM ANY REMEDIES WHICH BUYER MAY HAVE HEREUNDER AND SHALL BE GIVEN FULL FORCE AND EFFECT WHETHER OR NOT ANY OR ALL SUCH REMEDIES SHALL BE DEEMED TO HAVE FAILED OF THEIR ESSENTIAL PURPOSE.

10. **GOVERNING LAW AND ASSIGNMENT** - The laws of the State of Georgia shall govern the validity, interpretation and enforcement of this contract, without regard to its conflicts of law principles. The application of the United Nations Convention on Contracts for the International Sale of Goods shall be excluded. Assignment may be made only with written consent of both parties; provided, however, Seller may assign to its affiliate without Buyer's consent.

11. **ATTORNEY FEES** - Buyer shall be liable to Seller for any attorney fees and costs incurred by Seller in enforcing any of its rights hereunder.

12. **DISPUTES** - Either party may give the other party written notice of any dispute arising out of or relating to this contract and not resolved in the normal course of business. The parties shall attempt in good faith to resolve such dispute promptly by negotiations between executives who have authority to settle the dispute. If the matter has not been resolved within 60 days of the notice, either party may initiate non-binding mediation of the dispute.

13. **STATUTE OF LIMITATIONS** - To the extent permitted by applicable law, any lawsuit for breach of contract, including breach of warranty, arising out of the transactions covered by this contract, must be commenced not later than twelve (12) months from the date the cause of action accrued.

14. **PRICES** - In the event of a price increase or decrease, the price of goods on order will be adjusted to reflect such increase or decrease. This does not apply to a shipment held by request of Buyer. Goods already shipped are not subject to price increase or decrease. Orders on a bid or contract basis are not subject to this article. Seller's prices include the costs of standard domestic packing only. Any deviation from this standard packing (domestic or export), including U.S. Government sealed packing, will result in extra charges. To determine such extra charges, consult Seller's sales offices. Orders of less than \$400 will be charged a \$25 handling fee.

15. **ADDITIONAL TERMS OF PAYMENT** - Invoice payment terms are as shown on latest discount sheets as issued from time to time. Cash discounts are not applicable to notes or trade acceptances, to prepaid transportation charges when added to Seller's invoices or to discountable items if there are undisputed past due items on the account. Portions of an invoice in dispute should be deducted and the balance remitted with a detailed explanation of the deduction. Cash discounts will only be allowed on that portion of the invoice paid within the normal discount period.

16. **CHANGES IN LAWS AND REGULATIONS** - Seller's prices and timely performance are based on all applicable laws, rules, regulations, orders, codes, standards or requirements of governmental authorities effective on the date of Seller's proposal. Any change to any law, rule, regulation, order, code, standard or requirement which requires any change hereunder shall entitle Seller to an equitable adjustment in the prices and any time of performance.

# Appendix

Notes

11



# Appendix

Notes

11