



SIEMENS

Ingenuity for life



Commercial SPD Catalog

Surge Protective Devices



2016

usa.siemens.com/spd

Siemens full line of Surge Protective Devices

UL 1449 4th Edition In today's electronic world, home and business electrical systems aren't complete unless they incorporate surge protection. This is best accomplished by Stopping Surges Before They Get In through the application of hard-wired surge protective devices (SPDs) at key surge entry paths located within an electrical system.

Locating SPD installation points is a relatively easy step in developing a surge protection plan. Selecting and sizing surge protective devices is not as simple, but Siemens has solutions for virtually all applications.

Even at their inception over 18 years ago, our Transient Protection System (TPS) family of surge protectors included a number of industry SPD safety control firsts including the patented Ceramgard and TranSafe circuitry, coordinated fusing and thermal cutouts, dielectric isolation,

mechanical reinforcing taping resulting in a design that ensured the highest possible electrical system protection and reliability.

Our next generation UL 1449 4th Edition TPS3 SPDs carry on this same legacy by maintaining the highest degree of safety while delivering the industry's best performance ratings – lowest Voltage Protection Ratings (VPRs), Type 1 and 20 kA I nominal ratings nearly across the board, and surge current ratings from 50 kA to 1000 kA. This safety and performance "know-how" is infused within every Siemens TPS.

Electrical disturbances will always occur, but they don't have to cause surge protectors to fail in an unsafe manner. Safer surge protection means uncompromised electrical system protection, safety, and reliability.

Internal



External



Table of Contents

SPD Sizing Chart	4
External SPDs	(5-20)
TPS3 03	5
TPS3 03 DC	7
TPS3 09	9
TPS3 11	11
TPS3 12	13
TPS3 L12 (10-mode SPD)	15
TPS3 15	17
TPS3 L15 (10-mode SPD)	19
Internal SPDs	(21-32)
TPS3 01	21
TPS3 L1 (10-mode SPD)	23
TPS3 02	25
TPS3 L2 (10-mode SPD)	27
TPS3 05	29
TPS3 L5 (10-mode SPD)	31
TPS3 06	33
TPS3 L6 (10-mode SPD)	35
Frequently Asked Questions	37
Services & Support	38

Sizing Chart

Surge Protective Devices

Service Entrance Greater than 2000A		
Exposure Level	kA per phase	Model
High Exposure	300 kA	TPS3_1230
Medium Exposure	200 kA	TPS3_1220
Low Exposure	150 kA	TPS3_1215
Lowest Exposure	100 kA	TPS3_1110
Service Entrance 1200A - 2000A		
Exposure Level	kA per phase	Model
High Exposure	250 kA	TPS3_1225
Medium Exposure	200 kA	TPS3_1220
Low Exposure	150 kA	TPS3_1215
Lowest Exposure	100 kA	TPS3_0910
Service Entrance 800A - 1200A		
Exposure Level	kA per phase	Model
High Exposure	200 kA	TPS3_1120
Medium Exposure	150 kA	TPS3_1115
Low Exposure	100 kA	TPS3_0910
Lowest Exposure	50 kA	TPS3_0305
Distribution/Branch Panel 800A - 1200A		
Exposure Level	kA per phase	Model
High Exposure	200 kA	TPS3_1120
Medium Exposure	150 kA	TPS3_1115
Low Exposure	100 kA	TPS3_0910
Lowest Exposure	50 kA	TPS3_0305
Distribution/Branch Panel Less than 800A		
Exposure Level	kA per phase	Model
High Exposure	150 kA	TPS3_1115
Medium Exposure	100 kA	TPS3_1110
Low Exposure	100 kA	TPS3_0910
Lowest Exposure	50 kA	TPS3_0305



TPS3 03



TPS3 09



TPS3 11



TPS3 12

TPS3 03

Type 1 Surge Protective Device (SPD) Mounts External to Electrical Distribution Equipment

Features:

- UL 1449 4th Edition Listed Type 1, CSA 22.2 No. 269.1
- Type 1 SPD
- Mounts external to electrical distribution equipment
 - Recommended for Line Side or Load Side Applications
- Bracket included for multiple mounting options
- Large-block 34 mm square MOVs
- 20 kA I_n (most models)
- 200 kA SCCR (most models)
- All UL required OCP & safety coordination included
 - Type 1 SPDs intended for Line or Load side of Main Disconnect
- UL96A Lightning Protection Master Label compliant (@20kA I_n)
- Designed, manufactured and tested consistent with:
 - ANSI/IEEE C62.41.1-2002, C62.41.2-2002, C62.45-2002, C62.62-2010, C62.72-2007 & CSA C22.2 No. 269.1
 - 1992/2000 NEMA LS-1
 - NEC Article 285
 - IEC 61643, CE
- 5 year warranty

- SPD Specifications
 - Surge Current Rating Per Phase

Per Phase	L-N (L-G: Delta)
50 kA	50 kA
 - 100% monitoring (Every MOV is monitored)
 - Individually fused and thermally protected MOVs
 - Solid state bi-directional operation
 - Repetitive impulse: 5000 - 3kA - 8 x 20 μ s; 1000 - 10kA - 8 x 20 μ s
 - Less than 1 nanosecond response time
 - Relative humidity range: 0-95% non-condensing
 - Operating frequency: 47-63 Hz
 - Peak Operating temperature: +85°C (185°F)
 - Operating temperature: -40°C (-40°F) to +60°C (140°F)

- Standard Configuration
 - Standard NEMA 4X polycarbonate enclosure (UL 746C (f1), UL 94-5VA)
 - Wire size: Prewired with 3' (91.4 cm) of #10 AWG
 - Standard size: 3.25" x 3.25" x 3.3" (82.6 mm x 82.6 mm x 83.8 mm)
 - Standard weight: 2 lb. (0.9 kg)
- SPD Monitoring
 - LED indicators
- Options
 - N-G protection
 - Dry Contact & Audible Alarm (Dry Contact connection leads exit through nipple via #18 AWG)



Ordering Information

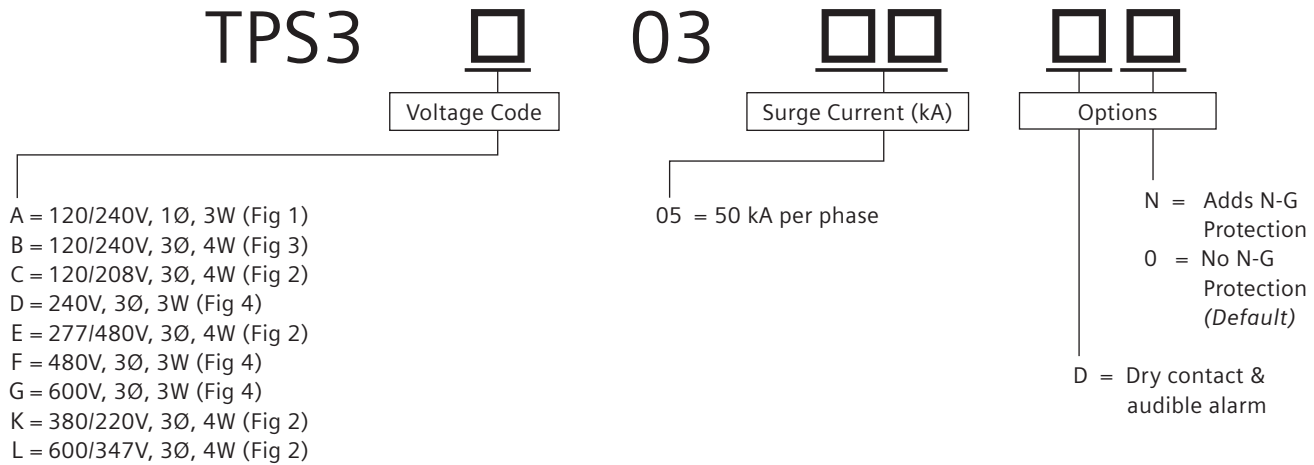

Example: TPS3C0305D0 = Type 1 SPD for a 208/120V application with a surge current capacity of 50 kA per phase, in a standard NEMA 4X enclosure with dry contacts and audible alarm option

**Available Accessories:
 Ordered Separately**
 RMSIE = Remote monitor

When an option is not selected, include a zero (0) in the field

UL 1449 Fourth Edition - Test Data								
Voltage Protection Rating (VPR - 6 kV, 3 kA)								
Voltage Code	Service Voltage	L-N	L-G*	N-G*	L-L	I _n	SCCR	MCOV
A	120/240V, 1Ø, 3W (Fig 1)	600	1000*	600*	100	20 kA	200kA	150
B	120/240V, 3Ø, 4W (Fig 3)	600/1200	1000/1500*	600*	100/1500	20 kA	200 kA	150/320
C	120/208V, 3Ø, 4W (Fig 2)	600	1000*	600*	1000	20 kA	200 kA	150
D	240V, 3Ø, 3W (Fig 4)	—	1200*	—	1500	20 kA	200 kA	320
E	277/480V, 3Ø, 4W (Fig 2)	1200	1800*	1000*	2000	20 kA	200 kA	320
F	480V, 3Ø, 3W (Fig 4)	—	1800*	—	3000	10 kA	200kA	550
G	600V, 3Ø, 3W (Fig 4)	—	1200*	—	1500	20 kA	200kA	690
K	380/220V, 3Ø, 4W (Fig 2)	1200	1800*	1000*	2000	20 kA	200kA	320
L	600/347V, 3Ø, 4W (Fig 2)	1500	2500*	1200*	2500	20 kA	200kA	420

*with optional N-G protection

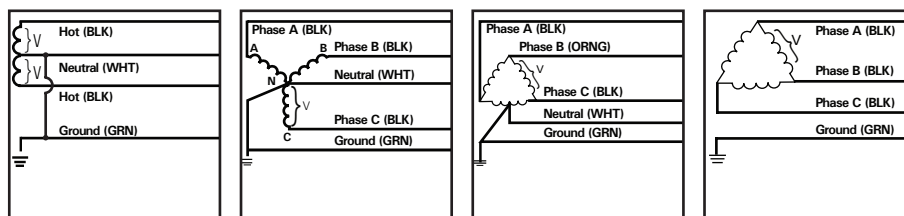

Figure 1
Split
2 Hots, 1 Neu, 1 Grnd

Figure 2
Wye
3 Hots, 1 Neu, 1 Grnd

Figure 3
Hi-Leg Delta (B High)
3 Hots, (B High),
1 Neu, 1 Grnd

Figure 4
Delta & HRG Wye
3 Hots, 1 Grnd

Siemens Industry, Inc.
 5400 Triangle Parkway
 Norcross, GA 30092
 888-333-3545
 info.us@siemens.com
 Order No. RPFL-S303C-0916
 Printed in USA
 All Rights Reserved.
 ©2016 Siemens Industry, Inc.

TPS3 03 DC

For DC Photovoltaic Applications

TPS3 03 DC is available in 300VDC, 600VDC and 1000VDC versions, which are designed to protect photovoltaic electrical systems. Typical PV installation would be on the DC solar panel side and also on the AC side of the inverter/ converter. SPDs are highly recommended when lightning activity is present to protect sensitive electrical photovoltaic components.

TPS3 03 DC is designed as a stand alone device in a NEMA 4X polycarbonate enclosure. Large block, thermally protected 50 kA MOVs are utilized. A green LED illuminates for diagnostic monitoring. TPS3 03 DC comes standard with a Tri-Mount installation kit which allows it to be Nipple, DIN-rail or Bracket mounted.

Diagram

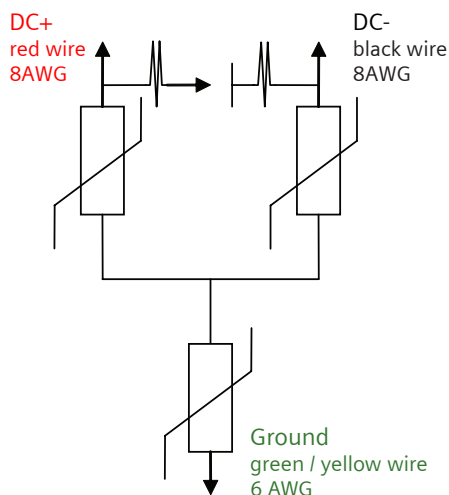

Tri-Mount Installation Mounting Kit Included



Dimensions

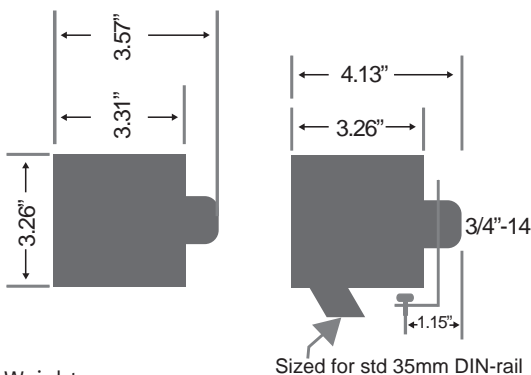

Weight:
1.60 lbs (0.73kg)



Performance Data				
Siemens Part Number		TPS3M0305	TPS3R0305	TPS3P0305
Modes of Protection		DC+ – DC- , DC+ – Ground, DC- – Ground		
Nominal Network Voltage	U_n	300VDC	600VDC	1000VDC
Technology		Large Block, Thermally Protected 50kA MOVs		
Maximum Continuous Operating Voltage DC	U_c	425VDC	760VDC	1180VDC
Maximum Surge Current (8/20 μ s)	I_{max}	50kA	50kA	50kA
Nominal Discharge Current (8/20 μ s)	I_n	20kA	20kA	10kA
Voltage Protection Level (3kA 8/20 μ s)	U_D	<600V	<1800V	<2500V
Operating Temperature		-40°C + 65°C		
Response Time	t_A	<1ns		
Installation mounting method		DIN Rail, Nipple or Bracket		
Enclosure Material		NEMA 4X Polycarbonate		
Wiring (red = + , black = - , green / yellow = gnd)		Pre-wired w/3'(~1m) of 8AWG + 6AWG Ground Conductor		
Diagnostic circuit		Low Consumption LED Indicator		
Safety Disconnectors		Thermal/Overcurrent Protection; Arc-Breaking Slide Gate		
UL Listing		UL 1449 Listed as Type 1 SPD as a DC SPD for PV and other types of DC applications		
Warranty		5 Years		

Siemens Industry, Inc.

5400 Triangle Parkway
Norcross, GA 30092

888-333-3545
info.us@siemens.com

Order No. RPFL-S303DC-0716

Printed in USA

All Rights Reserved.

©2016 Siemens Industry, Inc.

TPS3 09

Type 1 Surge Protective Device (SPD) Mounts External to Electrical Distribution Equipment or Internal to P1, P2 Lighting Panelboards, P3 Power Panelboards and Busway Systems

Features:

- UL 1449 4th Edition Listed Type 1, CSA 22.2 No. 269.1
- Type 1 SPD
- Mounts external to electrical distribution equipment
 - Weatherproof hub included
- Mounts internal to P1 panelboards & busway
 - P1 - Field retrofit or factory install
 - P2 and P3 - Factory install only

Consult factory for field retrofit
- Large block, individually fused, thermally protected, 50 kA MOVs
- 20 kA I_n (most models)
- 200 kA SCCR (most models)
- All UL required OCP & safety coordination included
 - Type 1 SPDs intended for Line or Load side of Main Disconnect
- UL96A Lightning Protection Master Label compliant (@20kA I_n)

- Designed, manufactured and tested consistent with:
 - ANSI/IEEE C62.41.1-2002, C62.41.2-2002, C62.45-2002, C62.62-2010, C62.72-2007 & CSA C22.2 No. 269.1
 - 1992/2000 NEMA LS-1
 - NEC Article 285
 - IEC 61643, CE
- 10 year warranty
- SPD Specifications
 - Surge Current Rating Per Phase

Per Phase	L-N	L-G	N-G
100 kA	50 kA	50 kA	50 kA

- 100% monitoring (Every MOV is monitored, incl. N-G)
- Individually fused and thermally protected MOVs
- Solid state bi-directional operation
- Repetitive impulse: 5,000 hits
- Less than 1 nanosecond response time
- Relative humidity range: 0-95% non-condensing
- Operating frequency: 47-63 Hz
- Operating temperature: -40°C (-40°F) to +85°C (185°F)
- Standard Configuration
 - Standard NEMA 4X polycarbonate enclosure (UL 746C (f1), UL 94-5VA)
 - Wire size: Prewired with 3' (91.4 cm) of #10 AWG
 - Standard size: 8.3" x 3.6" x 3.0" (211 mm x 91 mm x 77 mm)
 - Standard weight: 3 lb. (1.4 kg)
- SPD Monitoring
 - LED indicators



Ordering Information

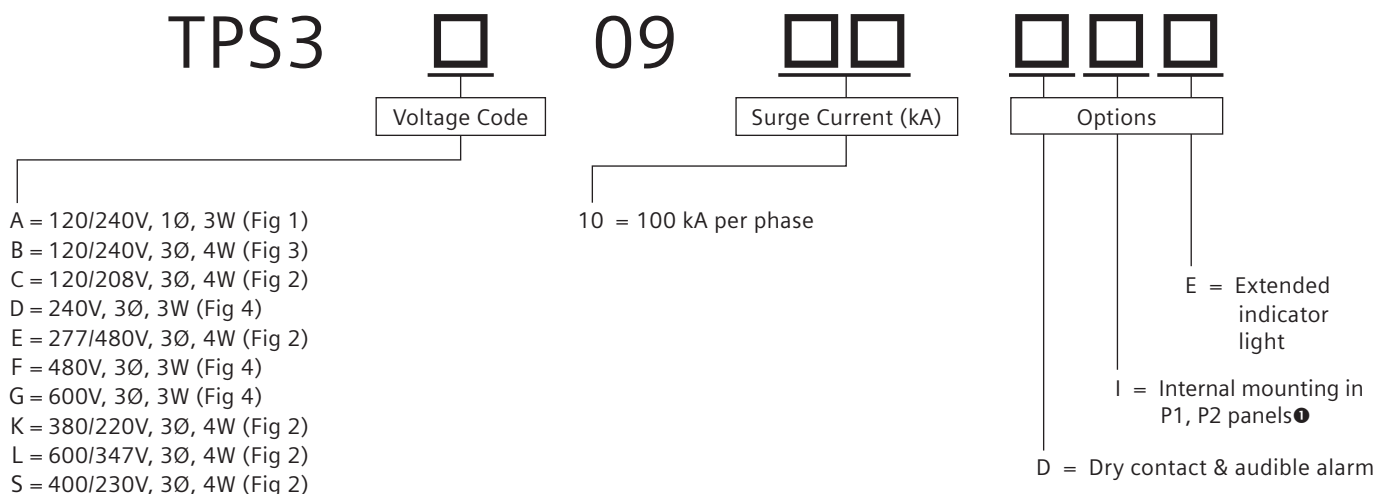

Example: TPS3C0910D00 = Type 1 SPD for a 208/120V panelboard with a surge current capacity of 100 kA per phase with standard NEMA 4X enclosure, dry contacts and audible alarm option.

Available for field retrofit in P1 panels

When an option is not selected, include a zero (0) in the field

Available Accessories:

Ordered Separately

RMSIE = Remote monitor
 XFMFKIT = Flush mount plate
 TPS9IKITP1 = Mounting bracket for installation in P1 panels
 TPS9IKITP2 = Mounting bracket for installation in P2 panels (factory install only)

UL 1449 Fourth Edition - Test Data Voltage Protection Rating (VPR - 6 kV, 3 kA)

Voltage Code	Service Voltage	L-N	L-G	N-G	L-L	I _n	SCCR	MCOV
A	120/240V, 1Ø, 3W (Fig 1)	600	700	500	1000	20 kA	100 kA	150
B	120/240V, 3Ø, 4W (Fig 3)	600/1200	700 /1200	500	1000/1000	20 kA	200 kA	150/320
C	120/208V, 3Ø, 4W (Fig 2)	600	700	500	1000	20 kA	200 kA	150
D	240V, 3Ø, 3W (Fig 4)	—	1200	—	1200	20 kA	200 kA	320
E	277/480V, 3Ø, 4W (Fig 2)	1200	1200	1000	1800	20 kA	200 kA	320
F	480V, 3Ø, 3W (Fig 4)	—	1800	—	1800	10 kA	200 kA	552
G	600V, 3Ø, 3W (Fig 4)	—	2500	—	2500	10 kA	200 kA	690
K	380/220V, 3Ø, 4W (Fig 2)	1200	1200	1000	1800	20 kA	200 kA	320
L	600/347V, 3Ø, 4W (Fig 2)	1500	1500	1500	2500	10 kA	200 kA	420
S	400/230V, 3Ø, 4W (Fig 2)	1200	1200	1000	1800	20 kA	200 kA	320

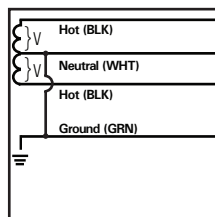

Figure 1

Split
 2 Hots, 1 Neu, 1 Grnd

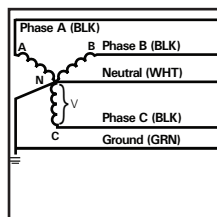

Figure 2

Wye
 3 Hots, 1 Neu, 1 Grnd

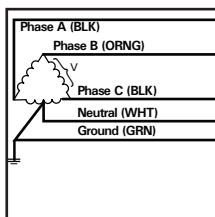

Figure 3

Hi-Leg Delta (B High)
 3 Hots, (B High),
 1 Neu, 1 Grnd

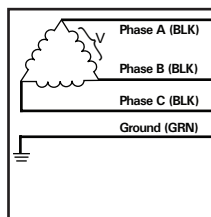

Figure 4

Delta & HRG Wye
 3 Hots, 1 Grnd

Siemens Industry, Inc.

5400 Triangle Parkway
 Norcross, GA 30092

888-333-3545
 info.us@siemens.com

Order No. RPFL-S309C-0916

Printed in USA

All Rights Reserved.

©2016 Siemens Industry, Inc.

TPS3 11

Type 1 / Type 2 Surge Protective Device (SPD) Mounts External to Electrical Distribution Equipment

Features:

- UL 1449-4 Type 2 SPD, UL 1283 Listed, CSA 22.2 No. 269.2
- Optional UL 1449 4th Edition Listed Type 1, CSA 22.2 No. 269.1
- Type 1 / Type 2 SPD
- Mounts external to electrical distribution equipment
- Large block, individually fused, thermally protected, 50 kA MOVs
- 20 kA I_n (most models)
- 200 kA SCCR (most models)
- All UL required OCP & safety coordination included
 - Type 1 SPDs intended for Line or Load side of Main Disconnect
 - Type 2 SPDs intended for Load side of Main Disconnect
- UL96A Lightning Protection Master Label compliant (@20kA I_n)
- Designed, manufactured and tested consistent with:
 - ANSI/IEEE C62.41.1-2002, C62.41.2-2002, C62.45-2002, C62.62-2010, C62.72-2007 & CSA C22.2 No. 269.1 and .2
 - 1992/2000 NEMA LS-1
 - NEC Article 285
 - IEC 61643, CE
- 10 year warranty

SPD Specifications

- Surge Current Rating Per Phase

Per Phase	L-N	L-G	N-G
100 kA	50 kA	50 kA	50 kA
150 kA	100 kA	50 kA	50 kA
200 kA	100 kA	100 kA	100 kA
- 100% monitoring (Every MOV is monitored, incl. N-G)
- Individually fused and thermally protected MOVs
- Solid state bi-directional operation
- EMI/RFI filtering: Active tracking up to -50 db from 10 kHz to 100 MHz (Type 2 option only, includes UL 1283 Listing)
- Repetitive impulse: 5,000 hits
- Less than 1 nanosecond response time

- Relative humidity range: 0-95% non-condensing
- Operating frequency: 47-63 Hz
- Operating temperature: -25°C (-15°F) to +60°C (140°F)
- Standard Configuration
 - Standard NEMA 4X polycarbonate enclosure (UL 746C (f1), UL 94-5VA)
 - Wire size: #8 AWG to #10 AWG
 - Standard size: 6" x 6" x 4" (152 mm x 152 mm x 102 mm)
 - Standard weight: 5 lb. (2.27 kg)
- SPD Monitoring
 - LED indicators



Ordering Information

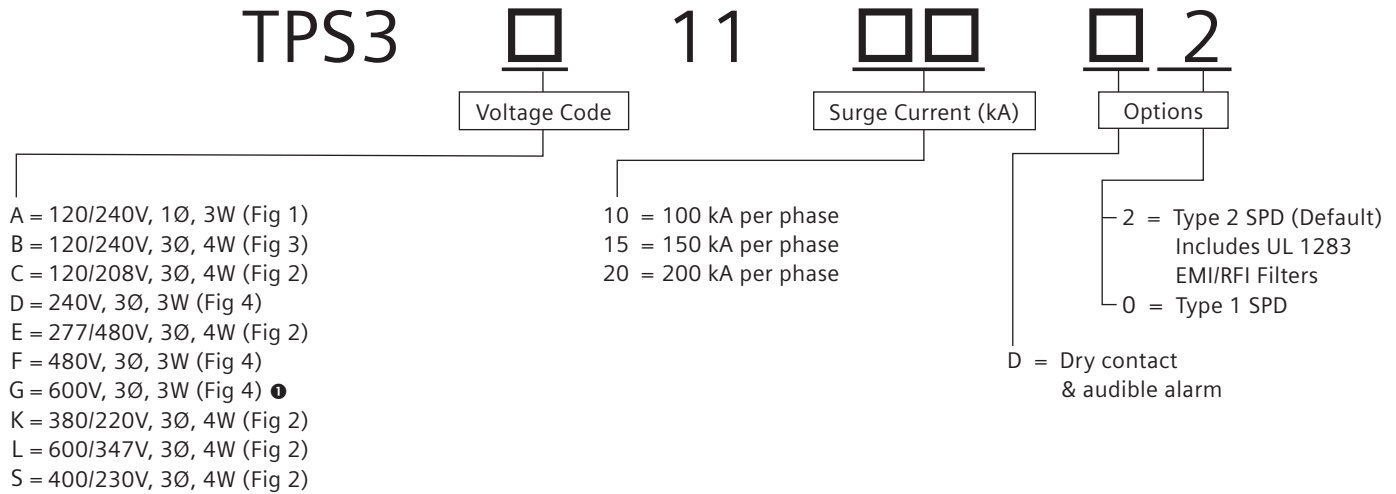

Example: TPS3C1110D2 = Type 2 SPD (Default) for a 208/120V application with a surge current capacity of 100 kA per phase, in a standard NEMA 4X enclosure with dry contacts and audible alarm option

When option 'D' is NOT selected, include a zero (0) in the field.

**Available Accessories:
 Ordered Separately**
 RMSIE - Remote monitor
 KITFMXF = Flush mount plate

UL 1449 Fourth Edition - Test Data Voltage Protection Rating (VPR - 6 kV, 3 kA)								
Voltage Code	Service Voltage	L-N	L-G	N-G	L-L	I _n	SCCR	MCOV
A	120/240V, 1Ø, 3W (Fig 1)	700	700	600	1000	20 kA	100 kA	150
B	120/240V, 3Ø, 4W (Fig 3)	700 /1200	700 /1200	600	1000	20 kA	200 kA	150 / 320
C	120/208V, 3Ø, 4W (Fig 2)	700	700	600	1000	20 kA	200 kA	150
D	240V, 3Ø, 3W (Fig 4)	—	1200	—	2000	20 kA	200 kA	320
E	277/480V, 3Ø, 4W (Fig 2)	1200	1200	1200	2000	20 kA	200 kA	320
F	480V, 3Ø, 3W (Fig 4)	—	1800	—	2000	10 kA	200 kA	552
G	600V, 3Ø, 3W (Fig 4)	—	2500	—	2500	10 kA	200 kA	690
K	380/220V, 3Ø, 4W (Fig 2)	1200	1200	1200	2000	20 kA	200 kA	320
L	600/347V, 3Ø, 4W (Fig 2)	1500	1500	1500	2500	10 kA	200 kA	420
S	400/230V, 3Ø, 4W (Fig 2)	1200	1200	1200	2000	20 kA	200 kA	320

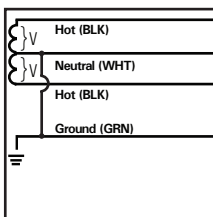

Figure 1
 Split
 2 Hots, 1 Neu, 1 Grnd

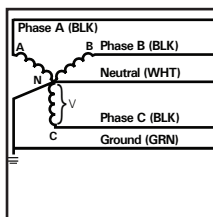

Figure 2
 Wye
 3 Hots, 1 Neu, 1 Grnd

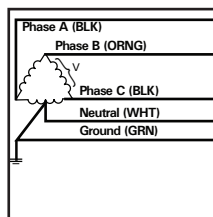

Figure 3
 Hi-Leg Delta (B High)
 3 Hots, (B High),
 1 Neu, 1 Grnd

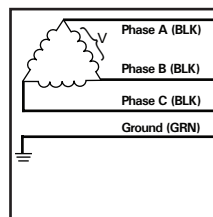

Figure 4
 Delta & HRG Wye
 3 Hots, 1 Grnd

Notes:

- Available in 100 kA per phase only

Siemens Industry, Inc.
 5400 Triangle Parkway
 Norcross, GA 30092

888-333-3545
 info.us@siemens.com

Order No. RPFL-S311C-0716
 Printed in USA

All Rights Reserved.
 ©2016 Siemens Industry, Inc.

TPS3 12

Type 1 / Type 2 Surge Protective Device (SPD) For Line Side or Load Side Applications

Features:

- UL 1449-4 Type 2 SPD, UL 1283 Listed, CSA 22.2 No. 269.2
- Optional UL 1449 4th Edition Listed Type 1, CSA 22.2 No. 269.1
- Type 1 / Type 2 SPD
- Mounts external to electrical distribution equipment
 - Recommended for line side or load side applications
- Large block, individually fused, thermally protected, 50 kA MOVs
- 20 kA I_n (most models)
- 200 kA SCCR (most models)
- Provides redundant replaceable module protection for low to high exposure applications
- All UL required OCP & safety coordination included
 - Type 1 SPDs intended for Line or Load side of Main Disconnect
 - Type 2 SPDs intended for Load side of Main Disconnect
- UL96A Lightning Protection Master Label compliant (@20kA I_n)

- Designed, manufactured and tested consistent with:
 - ANSI/IEEE C62.41.1-2002, C62.41.2-2002, C62.45-2002, C62.62-2010, C62.72-2007 & CSA C22.2 No. 269.1 and .2
 - 1992/2000 NEMA LS-1
 - NEC Article 285
 - IEC 61643, CE
- 10 year warranty

SPD Specifications

Surge Current Rating Per Phase

Per Phase	L-N	L-G	N-G
100 kA	50 kA	50 kA	50 kA
150 kA	100 kA	50 kA	50 kA
200 kA	100 kA	100 kA	100 kA
250 kA	150 kA	100 kA	100 kA
300 kA	150 kA	150 kA	150 kA
400 kA	200 kA	200 kA	200 kA
500 kA	250 kA	250 kA	250 kA

- 100% monitoring (Every MOV is monitored, incl. N-G)
- Individually fused and thermally protected MOVs
- Solid state bi-directional operation
- EMI/RFI filtering: Active tracking up to -50 db from 10 kHz to 100 MHz (Type 2 option only, includes UL 1283 Listing)
- Repetitive impulse: 5,000 hits
- Less than 1 nanosecond response time
- Relative humidity range: 0 -95% non-condensing
- Operating frequency: 47-63 Hz
- Operating temperature: -25°C (-15°F) to +60°C (140°F)



- Standard Configuration
 - Standard NEMA 1/12/3R/04 ANSI 61 steel enclosure
 - Internal rotary disconnect switch
 - Wire size: #8 AWG to 1/0
 - Standard size: 12" x 12" x 7" (305 mm x 305 mm x 178 mm) *
 - Standard weight: 20 lb. (9.07 kg)*
- SPD Monitoring
 - LED indicators
 - Audible alarm with silence switch and test button
 - Dry contacts
 - Surge counter

*Internal disconnect options and other NEMA ratings may increase enclosure size and weight

Ordering Information

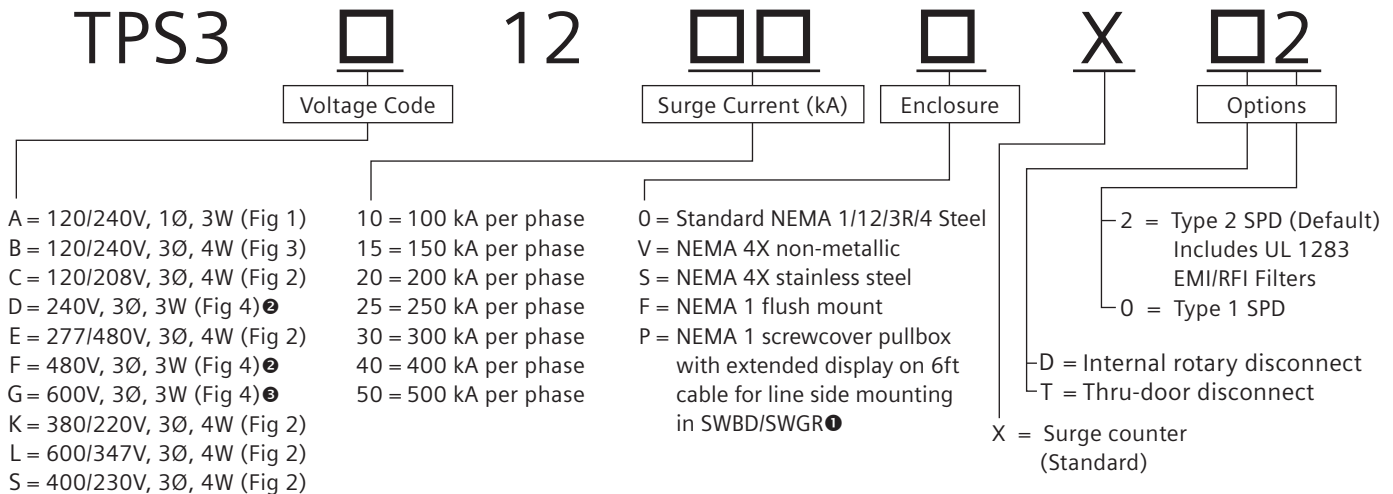

Example: TPS3C12100XD2 = Type 2 SPD (Default) for a 208/120V application with a surge current capacity of 100kA per phase, in a standard NEMA 1/12/3R/4 enclosure with a surge counter and internal rotary disconnect option

**Available Accessories:
Ordered Separately**
RMSIE - Remote monitor

When option 'X', 'T', or 'D' are NOT selected, include a zero (0) in the field.

UL 1449 Fourth Edition - Test Data
Voltage Protection Rating (VPR - 6 kV, 3 kA)⁴

Voltage Code	Service Voltage	L-N	L-G	N-G	L-L	I _n	SCCR	MCOV
A	120/240V, 1Ø, 3W (Fig 1)	700	700	700	1200	20 kA	100 kA	150
B	120/240V, 3Ø, 4W (Fig 3)	700/1200	700/1200	700	1800/1800	20 kA	200 kA	150 / 320
C	120/208V, 3Ø, 4W (Fig 2)	700	700	700	1200	20 kA	200 kA	150
D	240V, 3Ø, 3W (Fig 4)	—	1200	—	1200	20 kA	200 kA	320
E	277/480V, 3Ø, 4W (Fig 2)	1200	1200	1200	2000	20 kA	200 kA	320
F	480V, 3Ø, 3W (Fig 4)	—	1800	—	1800	20 kA	200 kA	552
G	600V, 3Ø, 3W (Fig 4)	—	2500	—	2500	10 kA	200 kA	690
K	380/220V, 3Ø, 4W (Fig 2)	1200	1200	1200	2000	20 kA	200 kA	320
L	600/347V, 3Ø, 4W (Fig 2)	1500	1500	1500	2500	20 kA	200 kA	420
S	400/230V, 3Ø, 4W (Fig 2)	1200	1200	1200	2000	20 kA	200 kA	320

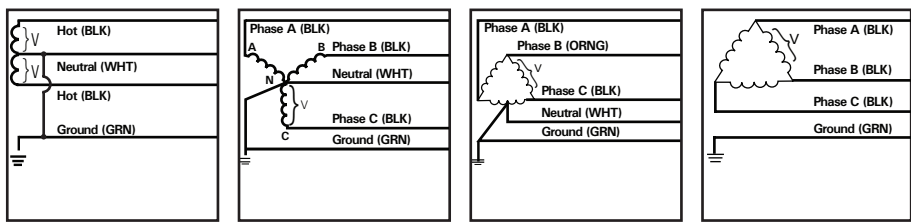

Figure 1 Split 2 Hots, 1 Neu, 1 Grnd
 Figure 2 Wye 3 Hots, 1 Neu, 1 Grnd
 Figure 3 Hi-Leg Delta (B High) 3 Hots, (B High), 1 Neu, 1 Grnd
 Figure 4 Delta & HRG Wye 3 Hots, 1 Grnd

- Notes:
- ① For line side mounting in SWBD/SWGR
 - ② Not available in 500kA
 - ③ Available in 100kA, 150kA, 200kA & 250 kA only
 - ④ VPR may increase when disconnect switch is added; VPR may decrease for products 400 & 500kA per phase

Siemens Industry, Inc.
 5400 Triangle Parkway
 Norcross, GA 30092
 888-333-3545
 info.us@siemens.com
 Order No. RPFL-S312C-0716
 Printed in USA
 All Rights Reserved.
 ©2016 Siemens Industry, Inc.

TPS3 L12

True 10 Mode Protection

Type 1 / Type 2 Surge Protective Device (SPD) For Line Side or Load Side Applications

Features:

- UL 1449-4 Type 2 SPD, UL 1283 Listed, CSA 22.2 No. 269.2
- Optional UL 1449 4th Edition Listed Type 1, CSA 22.2 No. 269.1
- Type 1 / Type 2 SPD
- Mounts external to electrical distribution equipment
 - Recommended for line side or load side applications
- Large block, individually fused, thermally protected, 50 kA MOVs
- 20 kA I_n (most models)
- 200 kA SCCR (most models)
- Single TPS1 style replaceable modules
- Provides replaceable module protection for low to high exposure applications
- All UL required OCP & safety coordination included
 - Type 1 SPDs intended for Line or Load side of Main Disconnect
 - Type 2 SPDs intended for Load side of Main Disconnect
- UL96A Lightning Protection Master Label compliant (@20kA I_n)

- Designed, manufactured and tested consistent with:
 - ANSI/IEEE C62.41.1-2002, C62.41.2-2002, C62.45-2002, C62.62-2010, C62.72-2007 & CSA C22.2 No. 269.1 and .2
 - 1992/2000 NEMA LS-1
 - NEC Article 285
 - IEC 61643, CE
- 10 year warranty

- SPD Specifications
 - Directly connected discrete protection elements between all possible modes providing true 10 mode protection
 - Surge Current Rating Per Phase

Per Phase	L-N	L-G	L-L	N-G
150 kA	50 kA	50 kA	50 kA	50 kA
300 kA	100 kA	100 kA	100 kA	100 kA
450 kA	150 kA	150 kA	150 kA	150 kA
 - 100% monitoring (Every MOV is monitored, incl. N-G)
 - Individually fused and thermally protected MOVs
- Solid state bi-directional operation
 - EMI/RFI filtering: Active tracking up to -50 db from 10 kHz to 100 MHz (Type 2 option only, includes UL 1283 Listing)
 - Repetitive impulse: 5,000 hits
 - Less than 1 nanosecond response time
 - Relative humidity range: 0 -95% non-condensing
 - Operating frequency: 47-63 Hz
 - Operating temperature: -25°C (-15°F) to +60°C (140°F)



- Standard Configuration
 - Standard NEMA 1/12/3R/04 ANSI 61 steel enclosure
 - Wire size: #8 AWG to 1/0
 - Standard size: 12" x 12" x 7" (305 mm x 305 mm x 178 mm) *
 - Standard weight: 20 lb. (9.07 kg) *
- SPD Monitoring
 - LED indicators
 - Audible alarm with silence switch and test button
 - Dry contacts
 - Surge counter

*Internal disconnect options and other NEMA ratings may increase enclosure size and weight

Ordering Information

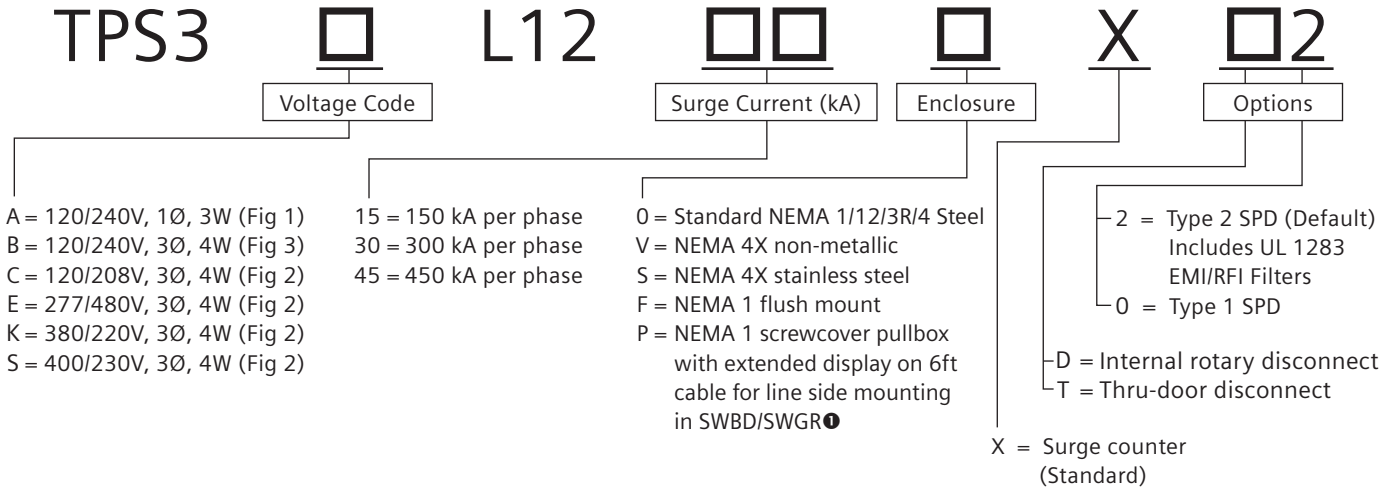

Example: TPS3CL12150XD2 = 10 Mode, Type 2 SPD (Default) for a 208/120V application with a surge current capacity of 150kA per phase, in a standard NEMA 1/12/3R/4 enclosure with a surge counter and internal rotary disconnect option

**Available Accessories:
 Ordered Separately**
 RMSIE - Remote monitor

When an option is not selected, include a zero (0) in the field

UL 1449 Fourth Edition - Test Data
 Voltage Protection Rating (VPR - 6 kV, 3 kA) ❷

Voltage Code	Service Voltage	L-N	L-G	N-G	L-L	I _n	SCCR	MCOV
A	120/240V, 1Ø, 3W (Fig 1)	700	700	700	1000	20 kA	100 kA	150
B	120/240V, 3Ø, 4W (Fig 3)	800/1500	700/1200	700	1800/1800	20 kA	200 kA	150 / 320
C	120/208V, 3Ø, 4W (Fig 2)	700	700	700	1000	20 kA	200 kA	150
E	277/480V, 3Ø, 4W (Fig 2)	1200	1200	1200	1800	20 kA	200 kA	320
K	380/220V, 3Ø, 4W (Fig 2)	1200	1200	1200	1800	20 kA	200 kA	320
S	400/230V, 3Ø, 4W (Fig 2)	1200	1200	1200	1800	20 kA	200 kA	320

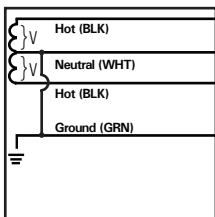

Figure 1
 Split
 2 Hots, 1 Neu, 1 Grnd

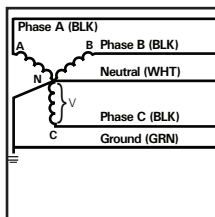

Figure 2
 Wye
 3 Hots, 1 Neu, 1 Grnd

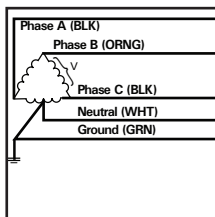

Figure 3
 Hi-Leg Delta (B High)
 3 Hots, (B High),
 1 Neu, 1 Grnd

Notes:

- ❶ For line side mounting in SWBD/SWGR
- ❷ VPR may decrease for 450kA per phase

Siemens Industry, Inc.
 5400 Triangle Parkway
 Norcross, GA 30092
 888-333-3545
 info.us@siemens.com

Order No. RPFL-S3L12-0716
 Printed in USA
 All Rights Reserved.
 ©2016 Siemens Industry, Inc.

TPS3 15

Type 1 / Type 2 Surge Protective Device (SPD) For Line Side or Load Side Applications

Features:

- UL 1449-4 Type 2 SPD, UL 1283 Listed, CSA 22.2 No. 269.2
- Optional UL 1449 4th Edition Listed Type 1, CSA 22.2 No. 269.1
- Type 1 / Type 2 SPD
- Mounts external to electrical distribution equipment
 - Recommended for line side or load side applications
- When "P" option is selected, TPS3 15, Type 1 SPD mounts internal to: SB1, SB3 and Type RCS switchboards, Type WL low voltage switchgear and TIASTAR motor control centers
- Large block, individually fused, thermally protected, 50 kA MOVs
- Internal rotary disconnect switch
- 20 kA I_n (most models)
- 200 kA SCCR (most models)
- Provides redundant replaceable module protection for low to high exposure applications
- All UL required OCP & safety coordination included
 - Type 1 SPDs intended for Line or Load side of Main Disconnect
 - Type 2 SPDs intended for Load side of Main Disconnect

- UL96A Lightning Protection Master Label compliant (@20kA I_n)
- Designed, manufactured and tested consistent with:
 - ANSI/IEEE C62.41.1-2002, C62.41.2-2002, C62.45-2002, C62.62-2010, C62.72-2007 & CSA C22.2 No. 269.1 and .2
 - 1992/2000 NEMA LS-1
 - NEC Article 285
 - IEC 61643, CE
- 10 year warranty

SPD Specifications

Surge Current Rating Per Phase	L-N	L-G	N-G
600 kA	300 kA	300 kA	300 kA
800 kA	400 kA	400 kA	400 kA
1000 kA	500 kA	500 kA	500 kA

- 100% monitoring (Every MOV is monitored, incl. N-G)
- Individually fused and thermally protected MOVs
- Solid state bi-directional operation
- EMI/RFI filtering: Active tracking up to -50 db from 10 kHz to 100 MHz (Type 2 option only, includes UL 1283 Listing)
- Repetitive impulse: 5,000 hits
- Less than 1 nanosecond response time
- Relative humidity range: 0 -95% non-condensing
- Operating frequency: 47-63 Hz
- Operating temperature: -25°C (-15°F) to +60°C (140°F)



- Standard Configuration
 - Standard NEMA 1/12/3R/04 ANSI 61 steel enclosure
 - Internal rotary disconnect switch
 - Wire size: #8 AWG to 1/0
 - Standard size: 20" x 20" x 7" (508 mm x 508 mm x 178 mm) *
 - Standard weight: 64 lb. (29 kg) *

*Other NEMA ratings may increase enclosure size and weight

- SPD Monitoring
 - LED indicators
 - Audible alarm with silence switch and test button
 - Dry contacts
 - Surge counter

Ordering Information

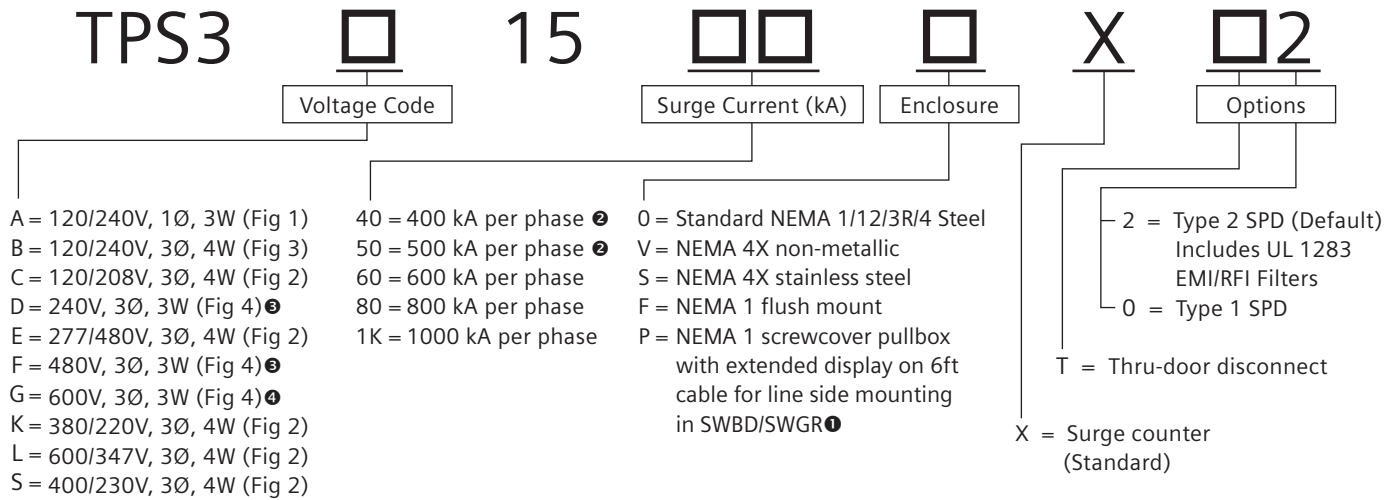

Example: TPS3C1560SX02 = Type 2 SPD (Default) for a 208/120V application with a surge current capacity of 600 kA per phase, in a NEMA 4X stainless steel enclosure with a surge counter and standard disconnect switch

**Available Accessories:
Ordered Separately**
RMSIE - Remote monitor

When an option is not selected, include a zero (0) in the field

UL 1449 Fourth Edition - Test Data								
Voltage Protection Rating (VPR - 6 kV, 3 kA)								
Voltage Code	Service Voltage	L-N	L-G	N-G	L-L	I _n	SCCR	MCOV
A	120/240V, 1Ø, 3W (Fig 1)	700	700	700	1000	20 kA	100 kA	150
B	120/240V, 3Ø, 4W (Fig 3)	700/1200	700/1200	700/1000	1000/1800	20 kA	200 kA	150 / 320
C	120/208V, 3Ø, 4W (Fig 2)	700	700	700	1000	20 kA	200 kA	150
D	240V, 3Ø, 3W (Fig 4)	—	1200	—	1200	20 kA	200 kA	320
E	277/480V, 3Ø, 4W (Fig 2)	1200	1200	1200	1800	20 kA	200 kA	320
F	480V, 3Ø, 3W (Fig 4)	—	1800	—	1800	20 kA	200 kA	550
G	600V, 3Ø, 3W (Fig 4)	—	2500	—	2500	10 kA	200 kA	690
K	380/220V, 3Ø, 4W (Fig 2)	1200	1200	1200	2000	20 kA	200 kA	320
L	600/347V, 3Ø, 4W (Fig 2)	1500	1500	1500	2500	20 kA	200 kA	420
S	400/230V, 3Ø, 4W (Fig 2)	1200	1200	1200	2000	20 kA	200 kA	320

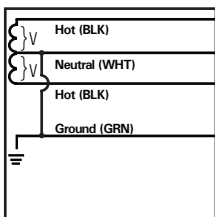

Figure 1
Split
2 Hots, 1 Neu, 1 Grnd

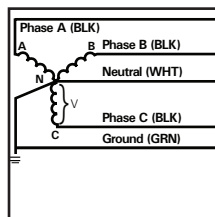

Figure 2
Wye
3 Hots, 1 Neu, 1 Grnd

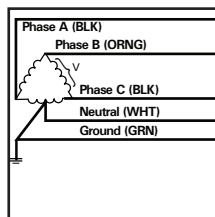

Figure 3
Hi-Leg Delta (B High)
3 Hots, (B High),
1 Neu, 1 Grnd

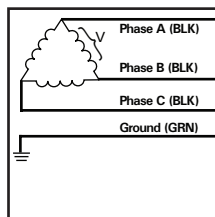

Figure 4
Delta & HRG Wye
3 Hots, 1 Grnd

Siemens Industry, Inc.
5400 Triangle Parkway
Norcross, GA 30092
888-333-3545
info.us@siemens.com

Order No. RPFL-S315C-0716
Printed in USA
All Rights Reserved.
©2016 Siemens Industry, Inc.

Notes:

- ❶ For line side mounting in SWBD/SWGR
- ❷ Available in 600 kA & 800 kA only
- ❸ Available in G voltage code only
- ❹ Available in 400 kA & 500 kA only

TPS3 L15

True 10 Mode Protection

Type 1 / Type 2 Surge Protective Device (SPD) For Line Side or Load Side Applications

Features:

- UL 1449-4 Type 2 SPD, UL 1283 Listed, CSA 22.2 No. 269.2
- Optional UL 1449 4th Edition Listed Type 1, CSA 22.2 No. 269.1
- Type 1 / Type 2 SPD
- Mounts external to electrical distribution equipment
 - Recommended for line side or load side applications
- When "P" option is selected, TPS3 15, Type 1 SPD mounts internal to: SB1, SB3 and Type RCS switchboards, Type WL low voltage switchgear and TIASTAR motor control centers
- Large block, individually fused, thermally protected, 50 kA MOVs
- 20 kA I_n (most models)
- 200 kA SCCR (most models)
- Single TPS6 style replaceable modules
- Provides redundant replaceable module protection for medium to high exposure applications
- Internal rotary disconnect switch included
- All UL required OCP & safety coordination included
 - Type 1 SPDs intended for Line or Load side of Main Disconnect

- Type 2 SPDs intended for Load side of Main Disconnect
- UL96A Lightning Protection Master Label compliant (@20kA I_n)
- Designed, manufactured and tested consistent with:
 - ANSI/IEEE C62.41.1-2002, C62.41.2-2002, C62.45-2002, C62.62-2010, C62.72-2007 & CSA C22.2 No. 269.1 and .2
 - 1992/2000 NEMA LS-1
 - NEC Article 285
 - IEC 61643, CE
- 10 year warranty

• SPD Specifications

Surge Current Rating Per Phase	L-N	L-G	L-L	N-G
600 kA	200 kA	200 kA	200kA	200kA
900 kA	300 kA	300 kA	300 kA	300 kA

- 100% monitoring (Every MOV is monitored, incl. N-G)
- Individually fused and thermally protected MOVs
- Solid state bi-directional operation
- EMI/RFI filtering: Active tracking up to -50 db from 10 kHz to 100 MHz (Type 2 option only, includes UL 1283 Listing)
- Repetitive impulse: 5,000 hits
- Less than 1 nanosecond response time
- Relative humidity range: 0 -95% non-condensing
- Operating frequency: 47-63 Hz
- Operating temperature: -25°C (-15°F) to +60°C (140°F)



- Standard Configuration
 - Standard NEMA 1/12/3R/04 ANSI 61 steel enclosure
 - Internal rotary disconnect switch
 - Wire size: #8 AWG to 1/0
 - Standard size: 20" x 20" x 7" (508 mm x 508 mm x 178 mm) *
 - Standard weight: 64 lb. (29 kg) *
- *Other NEMA ratings may increase enclosure size and weight

- SPD Monitoring
 - LED indicators
 - Audible alarm with silence switch and test button
 - Dry contacts
 - Surge counter

Ordering Information

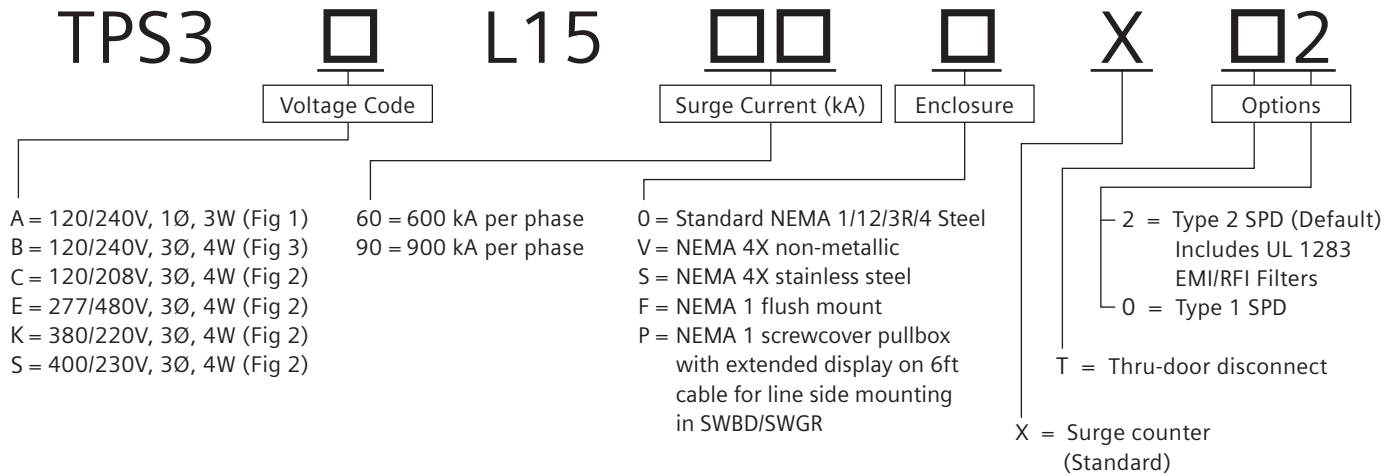

Example: TPS3CL15600X02 = 10 Mode, Type 2 SPD (Default) for a 208/120V application with a surge current capacity of 600 kA per phase, in a standard NEMA 1/12/3R/4 enclosure with a surge counter

**Available Accessories:
 Ordered Separately**
 RMSIE - Remote monitor

When an option is not selected, include a zero (0) in the field

UL 1449 Fourth Edition - Test Data								
Voltage Protection Rating (VPR - 6 kV, 3 kA)								
Voltage Code	Service Voltage	L-N	L-G	N-G	L-L	I _n	SCCR	MCOV
A	120/240V, 1Ø, 3W (Fig 1)	700	700	700	1000	20 kA	100 kA	150
B	120/240V, 3Ø, 4W (Fig 3)	700/1200	700/1200	700/1000	1000/1800	20 kA	200 kA	150 / 320
C	120/208V, 3Ø, 4W (Fig 2)	700	700	700	1000	20 kA	200 kA	150
E	277/480V, 3Ø, 4W (Fig 2)	1200	1200	1200	1800	20 kA	200 kA	320
K	380/220V, 3Ø, 4W (Fig 2)	1200	1200	1200	2000	20 kA	200 kA	320
S	400/230V, 3Ø, 4W (Fig 2)	1200	1200	1200	2000	20 kA	200 kA	320

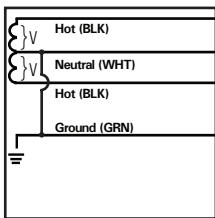

Figure 1
 Split
 2 Hots, 1 Neu, 1 Grnd

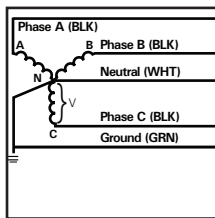

Figure 2
 Wye
 3 Hots, 1 Neu, 1 Grnd

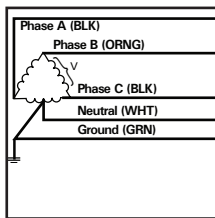

Figure 3
 Hi-Leg Delta (B High)
 3 Hots, (B High),
 1 Neu, 1 Grnd

Siemens Industry, Inc.
 5400 Triangle Parkway
 Norcross, GA 30092
 888-333-3545
 info.us@siemens.com

Order No. RPFL-S3L15-0716
 Printed in USA
 All Rights Reserved.
 ©2016 Siemens Industry, Inc.

TPS3 01

Type 1 / 2 Surge Protection Device (SPD) for P1, P2 Lighting Panelboards and P3 Power Distribution Panelboards, Motor Control Centers and Busway Systems

Features:

- Mounts internal to:
 - P1, P2 and P3 panels
 - TIASTAR motor control centers - standard 6" bucket
 - STP series busplug on SX series busway
- Consult factory for field retrofit in P1 panels
- UL 1449-4 Type 2 SPD, UL 1283 Listed, CSA 22.2 No. 269.2
- Optional UL 1449 4th Edition Recognized Type 1, CSA 22.2 No. 269.1
- Type 1 / Type 2 SPD
- Large block, individually fused, thermally protected, 50 kA MOVs
- 20 kA I_n (most models)
- 200 kA SCCR (most models)
- Direct bus connected or can be wired to a circuit breaker (include W option)
- UL96A Lightning Protection Master Label compliant (@20kA I_n)
- All UL required OCP & safety coordination included
 - Type 1 SPDs intended for Line or Load side of Main Disconnect
 - Type 2 SPDs intended for Load side of Main Disconnect

- Designed, manufactured and tested consistent with:
 - ANSI/IEEE C62.41.1-2002, C62.41.2-2002, C62.45-2002, C62.62-2010, C62.72-2007 & CSA C22.2 No. 269.1 and .2
 - 1992/2000 NEMA LS-1
 - NEC Article 285
 - IEC 61643, CE
- 10 year warranty

SPD Specifications

Surge Current Rating Per Phase

Per Phase	L-N	L-G	N-G
100 kA	50 kA	50 kA	50 kA
150 kA	100 kA	50 kA	50 kA
200 kA	100 kA	100 kA	100 kA
250 kA	150 kA	100 kA	100 kA
300 kA	150 kA	150 kA	150 kA

- 100% monitoring (Every MOV is monitored, incl. N-G)
- EMI/RFI filtering: Active tracking up to -50 db from 10 kHz to 100 MHz (Type 2 option only, includes UL 1283 Listing)
- Repetitive impulse: 5,000 hits
- Less than 1/2 nanosecond response time
- Relative humidity range: 1-95% non-condensing
- Operating frequency: 47-63 Hz
- Operating temperature: -25°C (-15°F) to +60°C (140°F)

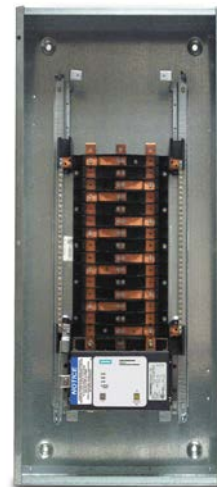

- Applications
 - Provides main service entrance or downstream protection for sensitive computer and electronic loads
 - Std. redundancy use: 100kA/phase
 - Inc. redundancy use: 200kA/phase
 - Max. redundancy use: 300kA/phase
- SPD Monitoring
 - LED indicators
 - Audible alarm with silence switch and test button
 - Dry contacts
 - Surge counter

Ordering Information

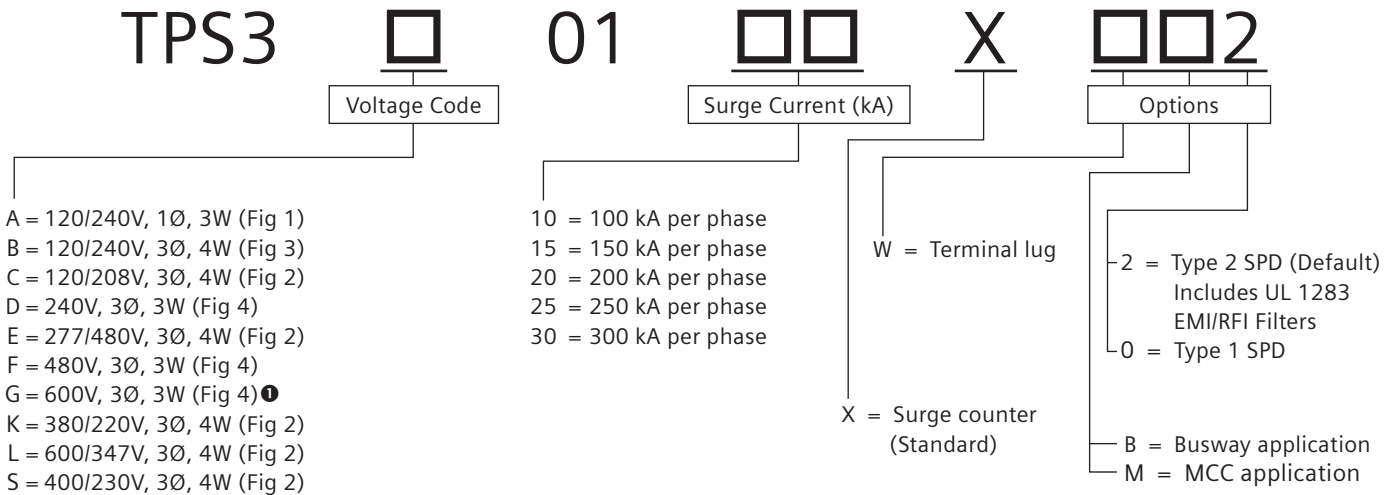

Example: TPS3C0120X002 = Type 2 SPD (Default) for a 208/120V panelboard with a surge current capacity of 200 kA per phase and a surge counter

**Available Accessories:
 Ordered Separately**
 RMSIE - Remote monitor

When an option is not selected, include a zero (0) in the field

UL 1449 Fourth Edition - Test Data
 Voltage Protection Rating (VPR - 6 kV, 3 kA)

Voltage Code	Service Voltage	L-N	L-G	N-G	L-L	I _n	Type	SCCR	MCOV
A	120/240V, 1Ø, 3W (Fig 1)	700	700	700	1200	20 kA	Type 4	100 kA	150
B	120/240V, 3Ø, 4W (Fig 3)	700/1200	700/1200	700	1800/1800	20 kA	Type 4	200 kA	150 / 320
C	120/208V, 3Ø, 4W (Fig 2)	700	700	700	1200	20 kA	Type 4	200 kA	150
D	240V, 3Ø, 3W (Fig 4)	—	1200	—	1200	10 kA	Type 4	200 kA	320
E	277/480V, 3Ø, 4W (Fig 2)	1200	1200	1200	2000	20 kA	Type 4	200 kA	320
F	480V, 3Ø, 3W (Fig 4)	—	1800	—	1800	10 kA	Type 4	200 kA	550
G	600V, 3Ø, 3W (Fig 4)	—	2500	—	2500	10 kA	Type 4	200 kA	690
K	380/220V, 3Ø, 4W (Fig 2)	1200	1200	1200	2000	20 kA	Type 4	200 kA	320
L	600/347V, 3Ø, 4W (Fig 2)	1500	1500	1500	2500	10 kA	Type 4	200 kA	420
S	400/230V, 3Ø, 4W (Fig 2)	1200	1200	1200	2000	20 kA	Type 4	200 kA	320

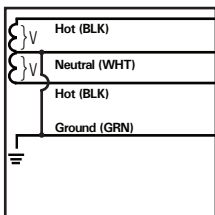

Figure 1
 Split
 2 Hots, 1 Neu, 1 Grnd

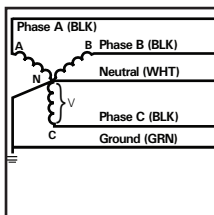

Figure 2
 Wye
 3 Hots, 1 Neu, 1 Grnd

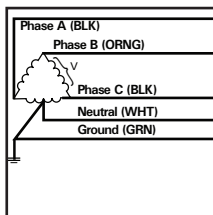

Figure 3
 Hi-Leg Delta (B High)
 3 Hots, (B High),
 1 Neu, 1 Grnd

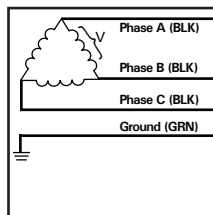

Figure 4
 Delta & HRG Wye
 3 Hots, 1 Grnd

Siemens Industry, Inc.
 5400 Triangle Parkway
 Norcross, GA 30092
 888-333-3545
 info.us@siemens.com

Order No. RPFL-S301C-0716
 Printed in USA
 All Rights Reserved.
 ©2016 Siemens Industry, Inc.

Notes:

- ❶ Available 100 kA & 150 kA only

TPS3 L1

True 10 Mode Protection

Type 1 / 2 Surge Protection Device (SPD) for P1, P2 Lighting and P3 Power Distribution Panelboards, Motor Control Centers and Busway Systems

Features:

- Mounts internal to:
 - P1, P2 and P3 panels
 - TIASTAR motor control centers - standard 6" bucket
 - STP series busplug on SX series busway
- Consult factory for field retrofit in P1 panels
- UL 1449-4 Type 2 SPD, UL 1283 Listed, CSA 22.2 No. 269.2
- Optional UL 1449 4th Edition Recognized Type 1, CSA 22.2 No. 269.1
- Type 1 / Type 2 SPD
- Large block, individually fused, thermally protected, 50 kA MOVs
- 20 kA I_n (most models)
- 200 kA SCCR (most models)
- Direct bus connected or can be wired to a circuit breaker (include W option)
- All UL required OCP & safety coordination included
 - Type 1 SPDs intended for Line or Load side of Main Disconnect
 - Type 2 SPDs intended for Load side of Main Disconnect

- Designed, manufactured and tested consistent with:

- ANSI/IEEE C62.41.1-2002, C62.41.2-2002, C62.45-2002, C62.62-2010, C62.72-2007 & CSA C22.2 No. 269.1 and .2
- 1992/2000 NEMA LS-1
- NEC Article 285
- IEC 61643, CE
- 10 year warranty

- SPD Specifications

- Directly connected discrete protection elements between all possible modes providing true 10 mode protection

- Surge Current Rating Per Phase

Per Phase	L-N	L-G	L-L	N-G
150 kA	50 kA	50 kA	50 kA	50 kA
300 kA	100 kA	100 kA	100 kA	100 kA

- 100% monitoring (Every MOV is monitored, incl. N-G)
- EMI/RFI filtering: Active tracking up to -50 db from 10 kHz to 100 MHz (Type 2 option only, includes UL 1283 Listing)
- Repetitive impulse: 5,000 hits
- Less than 1/2 nanosecond response time
- Relative humidity range: 1-95% non-condensing
- Operating frequency: 47-63 Hz
- Operating temperature: -25°C (-15°F) to +60°C (140°F)

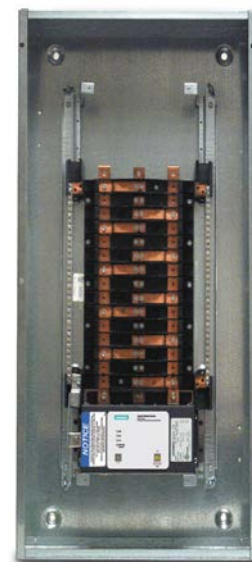

- Applications
 - Provides main service entrance or downstream protection for sensitive computer and electronic loads
 - Std. redundancy use: 150kA/phase
 - Max. redundancy use: 300kA/phase
- SPD Monitoring
 - LED indicators
 - Audible alarm with silence switch and test button
 - Dry contacts
 - Surge counter

Ordering Information

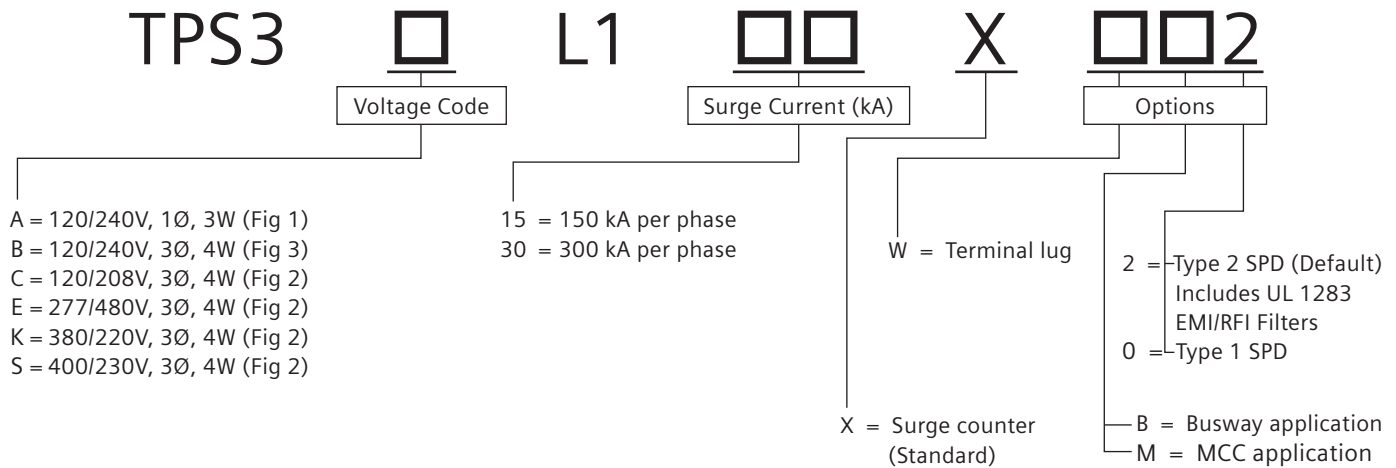

Example: TPS3CL130X002 = 10 Mode Type 2 SPD (Default) for a 208/120V panelboard with a surge current capacity of 300 kA per phase and a surge counter

**Available Accessories:
 Ordered Separately**
 RMSIE - Remote monitor

When an option is not selected, include a zero (0) in the field

UL 1449 Fourth Edition - Test Data Voltage Protection Rating (VPR - 6 kV, 3 kA)								
Voltage Code	Service Voltage	L-N	L-G	N-G	L-L	I _n	SCCR	MCOV
A	120/240V, 1Ø, 3W (Fig 1)	700	700	700	1000	20 kA	100 kA	150
B	120/240V, 3Ø, 4W (Fig 3)	800 /1500	700 /1200	700	1800/1800	20 kA	200 kA	150/320
C	120/208V, 3Ø, 4W (Fig 2)	700	700	700	1000	20 kA	200 kA	150
E	277/480V, 3Ø, 4W (Fig 2)	1200	1200	1200	1800	20 kA	200 kA	320
K	380/220V, 3Ø, 4W (Fig 2)	1200	1200	1200	1800	20 kA	200 kA	320
S	400/230V, 3Ø, 4W (Fig 2)	1200	1200	1200	1800	20 kA	200 kA	320

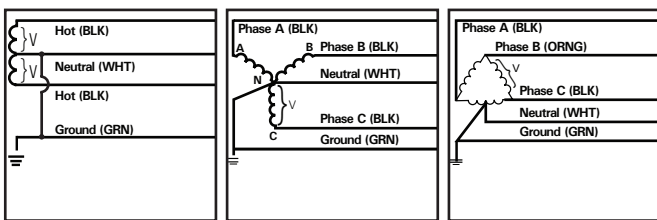

Figure 1
 Split
 2 Hots, 1 Neu, 1 Grnd

Figure 2
 Wye
 3 Hots, 1 Neu, 1 Grnd

Figure 3
 Hi-Leg Delta (B High)
 3 Hots, (B High),
 1 Neu, 1 Grnd

Siemens Industry, Inc.
 5400 Triangle Parkway
 Norcross, GA 30092
 888-333-3545
 info.us@siemens.com

Order No. RPFL-S3L1C-0716
 Printed in USA
 All Rights Reserved.
 ©2016 Siemens Industry, Inc.

TPS3 02

Type 1 / 2 Surge Protection Device (SPD) for Revised P1 Lighting Panelboards

Features:

- Mounts internal to:
 - Revised P1 Lighting Panelboards
- Consult factory for field retrofit in Revised P1 Lighting Panelboards
- UL 1449-4 Type 2 SPD, UL 1283 Listed, CSA 22.2 No. 269.2
- Optional UL 1449 4th Edition Recognized Type 1, CSA 22.2 No. 269.1
- Type 1 / Type 2 SPD
- Large block, individually fused, thermally protected, 50 kA MOVs
- 20 kA I_n (most models)
- 200 kA SCCR (most models)
- Direct bus connected
- Can be wired to a circuit breaker (consult factory at time of order or see installation manual for retrofit)
- UL96A Lightning Protection Master Label compliant (@20kA I_n)
- All UL required OCP & safety coordination included
 - Type 1 SPDs intended for Line or Load side of Main Disconnect
 - Type 2 SPDs intended for Load side of Main Disconnect

- Designed, manufactured and tested consistent with:
 - ANSI/IEEE C62.41.1-2002, C62.41.2-2002, C62.45-2002, C62.62-2010, C62.72-2007 & CSA C22.2 No. 269.1 and .2
 - 1992/2000 NEMA LS-1
 - NEC Article 285
 - IEC 61643, CE
- 10 year warranty
- SPD Specifications
 - Surge Current Rating Per Phase

Per Phase	L-N	L-G	N-G
100 kA	50 kA	50 kA	50 kA
150 kA	100 kA	50 kA	50 kA
200 kA	100 kA	100 kA	100 kA
250 kA	150 kA	100 kA	100 kA
300 kA	150 kA	150 kA	150 kA
 - 100% monitoring (Every MOV is monitored, incl. N-G)
 - EMI/RFI filtering: Active tracking up to -50 db from 10 kHz to 100 MHz (Type 2 option only, includes UL 1283 Listing)

- Repetitive impulse: 5,000 hits
- Less than 1/2 nanosecond response time
- Relative humidity range: 1-95% non-condensing
- Operating frequency: 47-63 Hz
- Operating temperature: -25°C (-15°F) to +60°C (140°F)



- Applications
 - Provides main service entrance or downstream protection for sensitive computer and electronic loads
 - Std. redundancy use: 100kA/phase
 - Inc. redundancy use: 200kA/phase
 - Max. redundancy use: 300kA/phase
- SPD Monitoring
 - LED indicators
 - Audible alarm with silence switch and test button
 - Dry contacts
 - Surge counter

Ordering Information

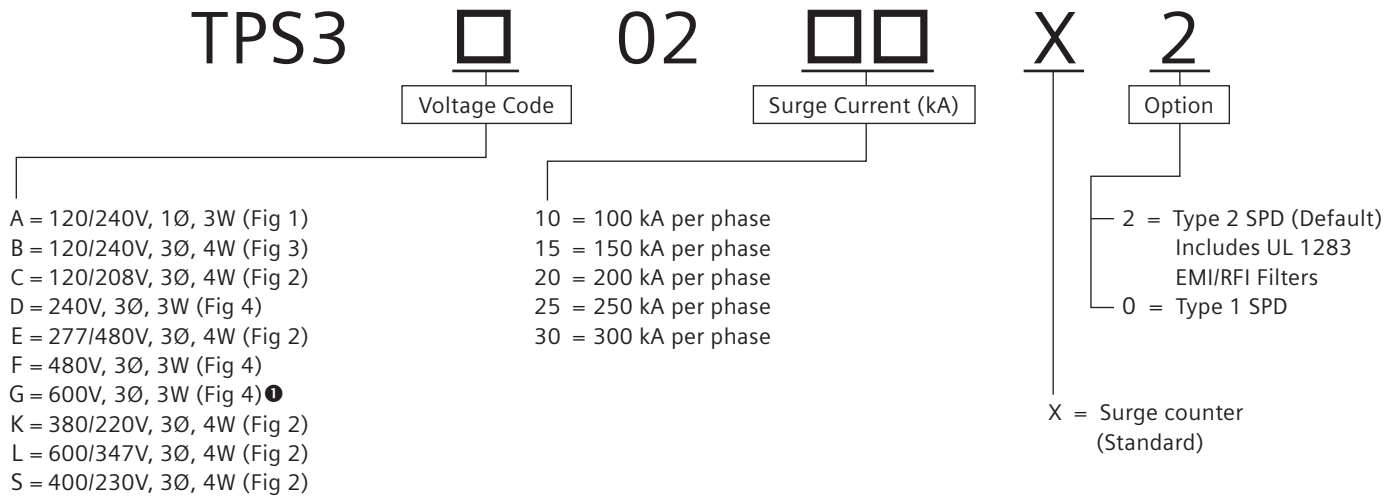

Example: TPS3C0220X2 = Type 2 SPD (Default) for a 208/120V panelboard with a surge current capacity of 200 kA per phase and a surge counter

**Available Accessories:
Ordered Separately**
RMSIE - Remote monitor

When an option is not selected, include a zero (0) in the field

UL 1449 Fourth Edition - Test Data Voltage Protection Rating (VPR - 6 kV, 3 kA)								
Voltage Code	Service Voltage	L-N	L-G	N-G	L-L	I _n	SCCR	MCOV
A	120/240V, 1Ø, 3W (Fig 1)	700	700	700	1200	20 kA	100 kA	150
B	120/240V, 3Ø, 4W (Fig 3)	700/1200	700/1200	700	1800/1800	20 kA	200 kA	150 / 320
C	120/208V, 3Ø, 4W (Fig 2)	700	700	700	1200	20 kA	200 kA	150
D	240V, 3Ø, 3W (Fig 4)	—	1200	—	1200	10 kA	200 kA	320
E	277/480V, 3Ø, 4W (Fig 2)	1200	1200	1200	2000	20 kA	200 kA	320
F	480V, 3Ø, 3W (Fig 4)	—	1800	—	1800	10 kA	200 kA	550
G	600V, 3Ø, 3W (Fig 4)	—	2500	—	2500	10 kA	200 kA	690
K	380/220V, 3Ø, 4W (Fig 2)	1200	1200	1200	2000	20 kA	200 kA	320
L	600/347V, 3Ø, 4W (Fig 2)	1500	1500	1500	2500	10 kA	200 kA	420
S	400/230V, 3Ø, 4W (Fig 2)	1200	1200	1200	2000	20 kA	200 kA	320

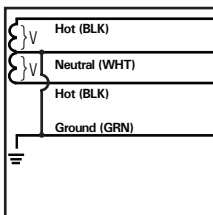

Figure 1
Split
2 Hots, 1 Neu, 1 Grnd

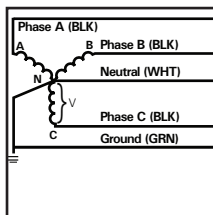

Figure 2
Wye
3 Hots, 1 Neu, 1 Grnd

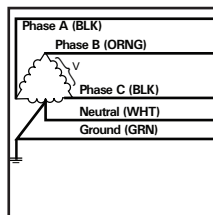

Figure 3
Hi-Leg Delta (B High)
3 Hots, (B High),
1 Neu, 1 Grnd

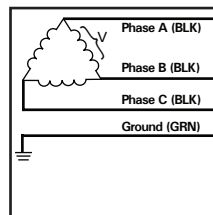

Figure 4
Delta & HRG Wye
3 Hots, 1 Grnd

Siemens Industry, Inc.
5400 Triangle Parkway
Norcross, GA 30092

888-333-3545
info.us@siemens.com

Order No. RPFL-S302C-0716
Printed in USA

All Rights Reserved.
©2016 Siemens Industry, Inc.

Notes:

- ❶ Available 100 kA & 150 kA only

TPS3 L2

True 10 Mode Protection

Type 1 / 2 Surge Protection Device (SPD) for Revised P1 Lighting Panelboards

Features:

- Mounts internal to:
 - Revised P1 Lighting Panelboards
- Consult factory for field retrofit in Revised P1 Lighting Panelboards
- UL 1449-4 Type 2 SPD, UL 1283 Listed, CSA 22.2 No. 269.2
- Optional UL 1449 4th Edition Recognized Type 1, CSA 22.2 No. 269.1
- Type 1 / Type 2 SPD
- Large block, individually fused, thermally protected, 50 kA MOVs
- 20 kA I_n (most models)
- 200 kA SCCR (most models)
- Direct bus connected
- Can be wired to a circuit breaker (consult factory at time of order or see installation manual for retrofit)
- UL96A Lightning Protection Master Label compliant (@20kA I_n)
- All UL required OCP & safety coordination included
 - Type 1 SPDs intended for Line or Load side of Main Disconnect
 - Type 2 SPDs intended for Load side of Main Disconnect

- Designed, manufactured and tested consistent with:
 - ANSI/IEEE C62.41.1-2002, C62.41.2-2002, C62.45-2002, C62.62-2010, C62.72-2007 & CSA C22.2 No. 269.1 and .2
 - 1992/2000 NEMA LS-1
 - NEC Article 285
 - IEC 61643, CE
- 10 year warranty
- SPD Specifications
 - Surge Current Rating Per Phase

Per Phase	L-N	L-G	L-L	N-G
150 kA	50 kA	50 kA	50 kA	50 kA
300 kA	100 kA	100 kA	100 kA	100 kA
 - 100% monitoring (Every MOV is monitored, incl. N-G)
 - EMI/RFI filtering: Active tracking up to -50 db from 10 kHz to 100 MHz (Type 2 option only, includes UL 1283 Listing)

- Repetitive impulse: 5,000 hits
- Less than 1/2 nanosecond response time
- Relative humidity range: 1-95% non-condensing
- Operating frequency: 47-63 Hz
- Operating temperature: -25°C (-15°F) to +60°C (140°F)



- Applications
 - Provides main service or downstream protection for sensitive computer and electronic loads
 - Standard redundancy use: 150 kA per phase
 - Maximum redundancy use: 300 kA per phase
- Standard Monitoring
 - LED indicators
 - Audible alarm with silence switch and test button
 - Dry contacts
 - Surge counter

Ordering Information

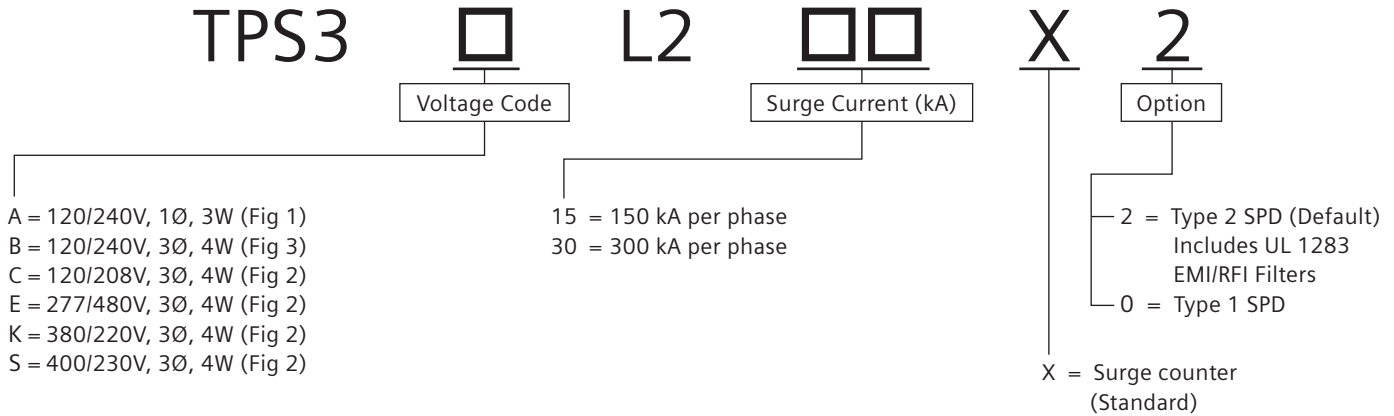

Example: TPS3CL230X2 = 10 Mode Type 2 SPD (Default) for a 208/120V panelboard with a surge current capacity of 300 kA per phase and a surge counter

**Available Accessories:
Ordered Separately**
RMSIE - Remote monitor

When an option is not selected, include a zero (0) in the field

UL 1449 Fourth Edition - Test Data
Voltage Protection Rating (VPR - 6 kV, 3 kA)

Voltage Code	Service Voltage	L-N	L-G	N-G	L-L	I _n	SCCR	MCOV
A	120/240V, 1Ø, 3W (Fig 1)	700	700	700	1000	20 kA	100 kA	150
B	120/240V, 3Ø, 4W (Fig 3)	800 /1500	700 /1200	700	1800/1800	20 kA	200 kA	150/320
C	120/208V, 3Ø, 4W (Fig 2)	700	700	700	1000	20 kA	200 kA	150
E	277/480V, 3Ø, 4W (Fig 2)	1200	1200	1200	1800	20 kA	200 kA	320
K	380/220V, 3Ø, 4W (Fig 2)	1200	1200	1200	1800	20 kA	200 kA	320
S	400/230V, 3Ø, 4W (Fig 2)	1200	1200	1200	1800	20 kA	200 kA	320

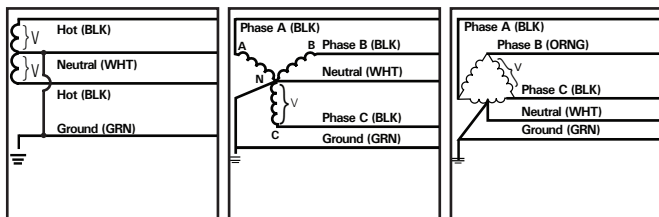

Figure 1 Split
2 Hots, 1 Neu, 1 Grnd

Figure 2 Wye
3 Hots, 1 Neu, 1 Grnd

Figure 3 Hi-Leg Delta (B High)
3 Hots, (B High),
1 Neu, 1 Grnd

Siemens Industry, Inc.
5400 Triangle Parkway
Norcross, GA 30092
888-333-3545
info.us@siemens.com
Order No. RPFL-S3L2C-0716
Printed in USA
All Rights Reserved.
©2016 Siemens Industry, Inc.

TPS3 05

Type 1 / 2 Surge Protection Device (SPD) for P4 & P5 Panelboards and Distribution Switchboards

Features:

- Mounts internal to:
 - P4 & P5 panelboards and distribution switchboards
- UL 1449-4 Type 2 SPD, UL 1283 Listed, CSA 22.2 No. 269.2
- Optional UL 1449 4th Edition Recognized Type 1, CSA 22.2 No. 269.1
- Type 1 / Type 2 SPD
- Large block, individually fused, thermally protected, 50 kA MOVs
- 20 kA I_n (most models)
- 200 kA SCCR (most models)
- All UL required OCP & safety coordination included
 - Type 1 SPDs intended for Line or Load side of Main Disconnect
 - Type 2 SPDs intended for Load side of Main Disconnect
- UL96A Lightning Protection Master Label compliant (@20kA I_n)
- Designed, manufactured and tested consistent with:
 - ANSI/IEEE C62.41.1-2002, C62.41.2-2002, C62.45-2002, C62.62-2010, C62.72-2007 & CSA C22.2 No. 269.1 and .2
 - 1992/2000 NEMA LS-1
 - NEC Article 285
 - IEC 61643, CE
- 10 year warranty

Panelboard Features

- Copper or aluminum bus
- MB or MLO

SPD Specifications

Surge Current Rating Per Phase

Per Phase	L-N	L-G	N-G
100 kA	50 kA	50 kA	50 kA
150 kA	100 kA	50 kA	50 kA
200 kA	100 kA	100 kA	100 kA
250 kA	150 kA	100 kA	100 kA
300 kA	150 kA	150 kA	150 kA

- 100% monitoring (Every MOV is monitored, incl. N-G)
- EMI/RFI filtering: Active tracking up to -50 db from 10 kHz to 100 MHz (Type 2 option only, includes UL 1283 Listing)
- Repetitive impulse: 5,000 hits
- Less than 1/2 nanosecond response time
- Relative humidity range: 1-95% non-condensing
- Operating frequency: 47-63 Hz
- Operating temperature: -25°C (-15°F) to +60°C (140°F)

Switchboard Features

- Copper or aluminum bus
- 200% rated neutral bus for harmonic-rich applications
- CSA, UL 891, UL 67 and NEMA PB-2



- Applications
 - Provides main service entrance or downstream protection for sensitive computer and electronic loads
 - Std. redundancy use: 100kA/phase
 - Inc. redundancy use: 200kA/phase
 - Max. redundancy use: 300kA/phase
- SPD Monitoring
 - LED indicators
 - Audible alarm with silence switch and test button
 - Dry contacts
 - Surge counter
 - Internal rotary disconnect switch

Ordering Information

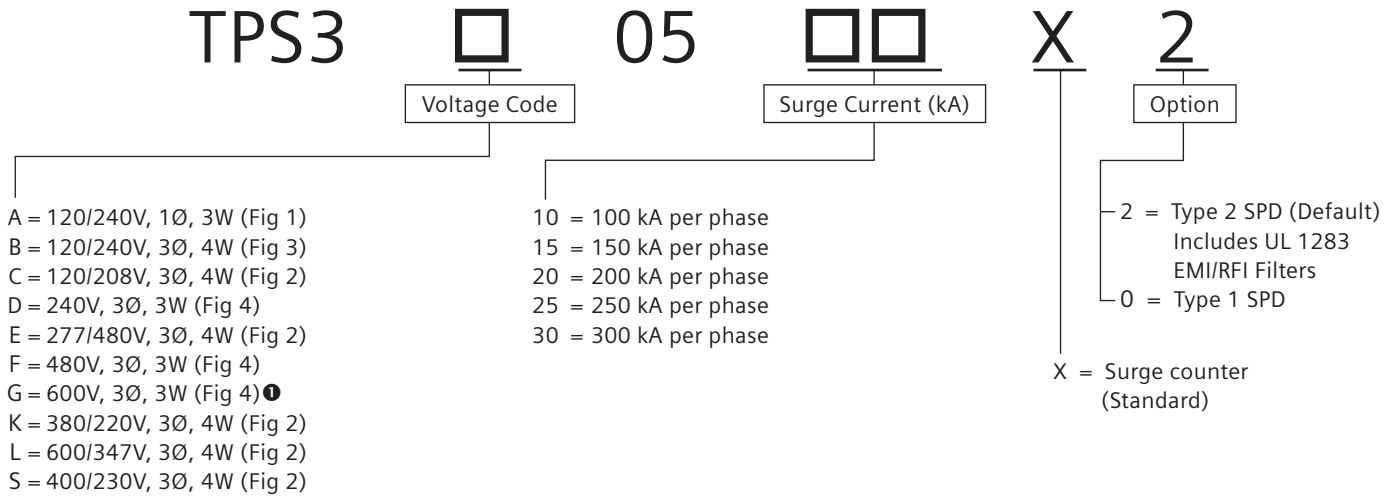

Example: TPS3C0530X2 = Type 2 SPD (Default) for a 208/120V power panel with a surge current capacity of 300 kA per phase and a surge counter

**Available Accessories:
Ordered Separately**
RMSIE - Remote monitor

When an option is not selected, include a zero (0) in the field

UL 1449 Fourth Edition - Test Data
Voltage Protection Rating (VPR - 6 kV, 3 kA)

Voltage Code	Service Voltage	L-N	L-G	N-G	L-L	I _n	SCCR	MCOV
A	120/240V, 1Ø, 3W (Fig 1)	700	700	700	1200	20 kA	100 kA	150
B	120/240V, 3Ø, 4W (Fig 3)	700/1500	700/1200	700	1800/1800	20 kA	200 kA	150 / 320
C	120/208V, 3Ø, 4W (Fig 2)	700	700	700	1200	20 kA	200 kA	150
D	240V, 3Ø, 3W (Fig 4)	—	1200	—	1500	20 kA	200 kA	320
E	277/480V, 3Ø, 4W (Fig 2)	1200	1200	1200	2000	20 kA	200 kA	320
F	480V, 3Ø, 3W (Fig 4)	—	1800	—	1800	10 kA	200 kA	552
G	600V, 3Ø, 3W (Fig 4)	—	2500	—	2500	10 kA	200 kA	690
K	380/220V, 3Ø, 4W (Fig 2)	1500	1200	1200	2500	20 kA	200 kA	320
L	600/347V, 3Ø, 4W (Fig 2)	1500	1500	1500	2500	10 kA	200 kA	420
S	400/230V, 3Ø, 4W (Fig 2)	1500	1200	1200	2500	20 kA	200 kA	320

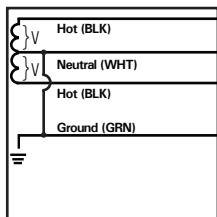

Figure 1
Split
2 Hots, 1 Neu, 1 Grnd

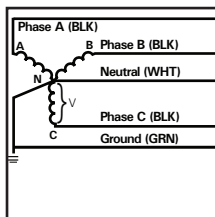

Figure 2
Wye
3 Hots, 1 Neu, 1 Grnd

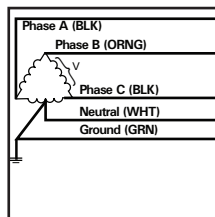

Figure 3
Hi-Leg Delta (B High)
3 Hots, (B High),
1 Neu, 1 Grnd

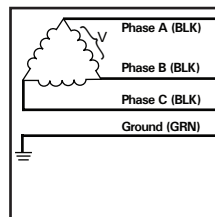

Figure 4
Delta & HRG Wye
3 Hots, 1 Grnd

Siemens Industry, Inc.
5400 Triangle Parkway
Norcross, GA 30092
888-333-3545
info.us@siemens.com

Order No. RPFL-S305C-0716
Printed in USA
All Rights Reserved.
©2016 Siemens Industry, Inc.

Notes:

- ❶ Available 100 kA & 150 kA only

TPS3 L5

True 10 Mode Protection

Type 1 / 2 Surge Protection Device (SPD) for P4 & P5 Panelboards and Distribution Switchboards

Features:

- Mounts internal to:
 - P4 & P5 panelboards and distribution switchboards
- UL 1449-4 Type 2 SPD, UL 1283 Listed, CSA 22.2 No. 269.2
- Optional UL 1449 4th Edition Recognized Type 1, CSA 22.2 No. 269.1
- Type 1 / Type 2 SPD
- Large block, individually fused, thermally protected, 50 kA MOVs
- Direct bus connected or can be wired to a circuit breaker (include W option)
- 20 kA I_n (most models)
- 200 kA SCCR (most models)
- All UL required OCP & safety coordination included
 - Type 1 SPDs intended for Line or Load side of Main Disconnect
 - Type 2 SPDs intended for Load side of Main Disconnect
- UL96A Lightning Protection Master Label compliant (@20kA I_n)

- Designed, manufactured and tested consistent with:

- ANSI/IEEE C62.41.1-2002, C62.41.2-2002, C62.45-2002, C62.62-2010, C62.72-2007 & CSA C22.2 No. 269.1 and .2
- 1992/2000 NEMA LS-1
- NEC Article 285
- IEC 61643, CE

- 10 year warranty

- Panelboard Features

- Copper or aluminum bus
- MB or MLO

- SPD Specifications

- Directly connected discrete protection elements between all possible modes providing true 10 mode protection
- Surge Current Rating Per Phase

Per Phase	L-N	L-G	L-L	N-G
150 kA	50 kA	50 kA	50 kA	50 kA
300 kA	100 kA	100 kA	100 kA	100 kA

- 100% monitoring (Every MOV is monitored, incl. N-G)
- EMI/RFI filtering: Active tracking up to -50 db from 10 kHz to 100 MHz (Type 2 option only, includes UL 1283 Listing)

- Repetitive impulse: 5,000 hits
- Less than 1/2 nanosecond response time
- Relative humidity range: 1-95% non-condensing
- Operating frequency: 47-63 Hz
- Operating temperature: -25°C (-15°F) to +60°C (140°F)

- Switchboard Features

- Copper or aluminum bus
- 200% rated neutral bus for harmonic-rich applications
- CSA, UL 891, UL 67 and NEMA PB-2



- Applications
 - Provides main service entrance or downstream protection for sensitive computer and electronic loads
 - Std. redundancy use: 150kA/phase
 - Max. redundancy use: 300kA/phase
- SPD Monitoring
 - LED indicators
 - Audible alarm with silence switch and test button
 - Dry contacts
 - Surge counter
 - Rotary disconnect switch

Ordering Information

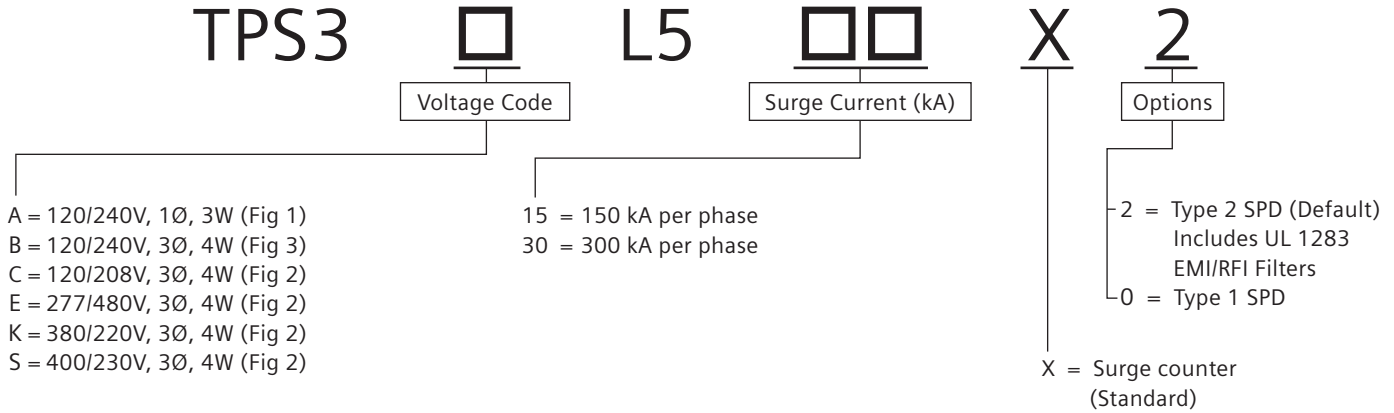

Example: TPS3CL530X2 = 10 mode Type 2 SPD (Default) for a 208/120V Power Panel with a surge current capacity of 300kA per phase and a surge counter

**Available Accessories:
 Ordered Separately**
 RMSIE - Remote monitor

When an option is not selected, include a zero (0) in the field

UL 1449 Fourth Edition - Test Data
 Voltage Protection Rating (VPR - 6 kV, 3 kA)

Voltage Code	Service Voltage	L-N	L-G	N-G	L-L	I _n	SCCR	MCOV
A	120/240V, 1Ø, 3W (Fig 1)	700	700	700	1200	20 kA	100 kA	150
B	120/240V, 3Ø, 4W (Fig 3)	800 /1500	700 /1200	700	1800/1800	20 kA	200 kA	150 / 320
C	120/208V, 3Ø, 4W (Fig 2)	700	700	700	1000	20 kA	200 kA	150
E	277/480V, 3Ø, 4W (Fig 2)	1500	1200	1200	1800	20 kA	200 kA	320
K	380/220V, 3Ø, 4W (Fig 2)	1500	1200	1200	1800	20 kA	200 kA	320
S	400/230V, 3Ø, 4W (Fig 2)	1500	1200	1200	1800	20 kA	200 kA	320

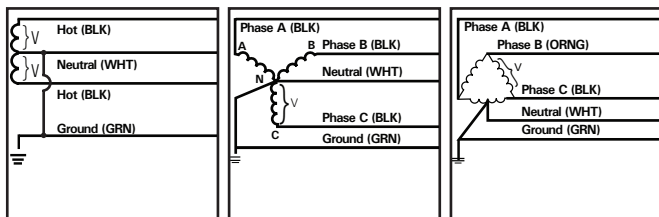

Figure 1
 Split
 2 Hots, 1 Neu, 1 Grnd

Figure 2
 Wye
 3 Hots, 1 Neu, 1 Grnd

Figure 3
 Hi-Leg Delta (B High)
 3 Hots, (B High),
 1 Neu, 1 Grnd

Siemens Industry, Inc.
 5400 Triangle Parkway
 Norcross, GA 30092
 888-333-3545
 info.us@siemens.com

Order No. RPFL-S3L5C-0716
 Printed in USA
 All Rights Reserved.
 ©2016 Siemens Industry, Inc.

TPS3 06

Type 1 / 2 Surge Protection Device (SPD) for Service Entrance Applications – SB1, SB2, SB3, Type RCS Switchboards, Type WL Low Voltage Switchgear, Motor Control Centers and Busway Systems

Features:

- Mounts internal to:
 - SB1, SB2, SB3 & Type RCS switchboards
 - Type WL low voltage switchgear
 - TIASTAR motor control centers - standard 12" bucket
 - STP series busplug on SX series busway
- UL 1449-4 Type 2 SPD, UL 1283 Listed, CSA 22.2 No. 269.2
- Optional UL 1449 4th Edition Recognized Type 1, CSA 22.2 No. 269.1
- Type 1 / Type 2 SPD
- Large block, individually fused, thermally protected, 50 kA MOVs
- 20 kA I_n (most models)
- 200 kA SCCR (most models)
- Rotary disconnect switch included
- All UL required OCP & safety coordination included
 - Type 1 SPDs intended for Line or Load side of Main Disconnect
 - Type 2 SPDs intended for Load side of Main Disconnect

- UL96A Lightning Protection Master Label compliant (@20kA I_n)
- Designed, manufactured and tested consistent with:
 - ANSI/IEEE C62.41.1-2002, C62.41.2-2002, C62.45-2002, C62.62-2010, C62.72-2007 & CSA C22.2 No. 269.1 and .2
 - 1992/2000 NEMA LS-1
 - NEC Article 285
 - IEC 61643, CE
- 10 year warranty

SPD Specifications

Surge Current Rating Per Phase

Per Phase	L-N	L-G	N-G
100 kA	50 kA	50 kA	50 kA
150 kA	100 kA	50 kA	50 kA
200 kA	100 kA	100 kA	100 kA
250 kA	150 kA	100 kA	100 kA
300 kA	150 kA	150 kA	150 kA
400 kA	200 kA	200 kA	200 kA
500 kA	250 kA	250 kA	250 kA

- 100% monitoring (Every MOV is monitored, incl. N-G)
- EMI/RFI filtering: Active tracking up to -50 db from 10 kHz to 100 MHz (Type 2 option only, includes UL 1283 Listing)
- Repetitive impulse: 5,000 hits
- Less than 1/2 nanosecond response time
- Relative humidity range: 1-95% non-condensing
- Operating frequency: 47-63 Hz
- Operating temperature: -25°C (-15°F) to +60°C (140°F)



- Applications
 - Provides main service entrance or downstream protection for sensitive computer and electronic loads
 - Std. redundancy use: 300kA/phase
 - Inc. redundancy use: 450kA/phase
 - Max. redundancy use: 500kA/phase

- SPD Monitoring
 - LED indicators
 - Audible alarm with silence switch and test button
 - Dry contacts
 - Surge counter
 - Rotary disconnect switch

Ordering Information

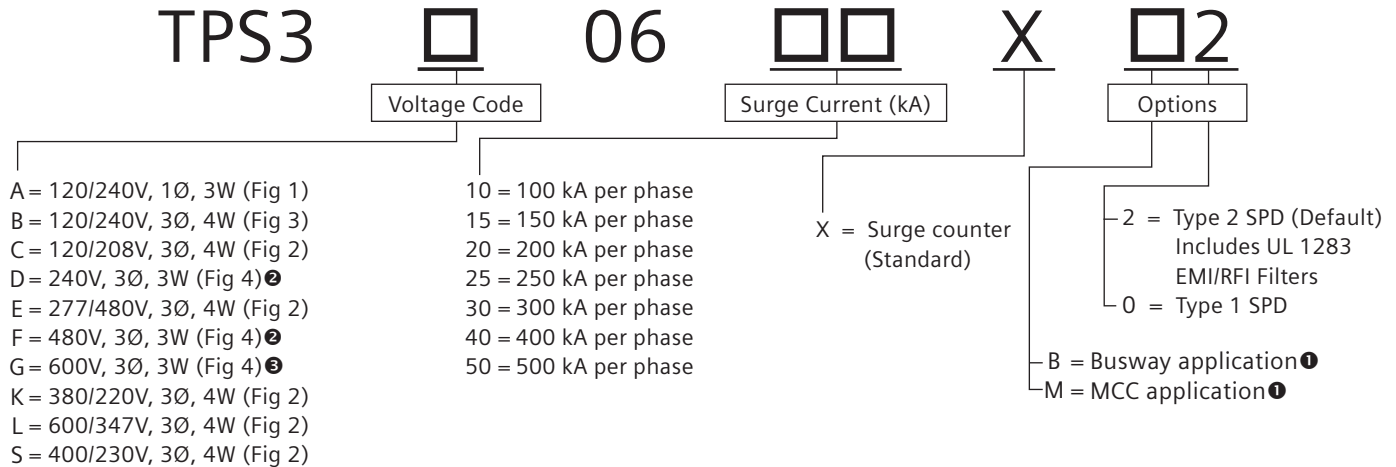

Example: TPS3C0640X002 = Type 2 SPD (Default) for a 208/120V switchboard with a surge current capacity of 400 kA per phase and a surge counter

When an option is not selected, include a zero (0) in the field

Available Accessories:

Ordered Separately

RMSIE - Remote monitor

WHXWDP120 = 10' Display cable extension

UL 1449 Fourth Edition - Test Data
Voltage Protection Rating (VPR - 6 kV, 3 kA) ④

Voltage Code	Service Voltage	L-N	L-G	N-G	L-L	I _n	SCCR	MCOV
A	120/240V, 1Ø, 3W (Fig 1)	700	700	700	1200	20 kA	100 kA	150
B	120/240V, 3Ø, 4W (Fig 3)	700/1200	700/1200	700	1800/1800	20 kA	200 kA	150 / 320
C	120/208V, 3Ø, 4W (Fig 2)	700	700	700	1200	20 kA	200 kA	150
D	240V, 3Ø, 3W (Fig 4)	—	1200	—	1200	20 kA	200 kA	320
E	277/480V, 3Ø, 4W (Fig 2)	1200	1200	1200	2000	20 kA	200 kA	320
F ⑤	480V, 3Ø, 3W (Fig 4)	—	1800	—	1800	20 kA	200 kA	550
G ⑤	600V, 3Ø, 3W (Fig 4)	—	2500	—	2500	10 kA	200 kA	690
K	380/220V, 3Ø, 4W (Fig 2)	1200	1200	1200	2000	20 kA	200 kA	320
L ⑤	600/347V, 3Ø, 4W (Fig 2)	1500	1500	1500	2500	20 kA	200 kA	420
S	400/230V, 3Ø, 4W (Fig 2)	1200	1200	1200	2000	20 kA	200 kA	320

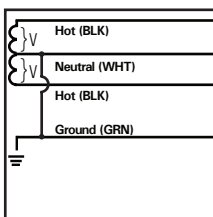

Figure 1

Split
 2 Hots, 1 Neu, 1 Grnd

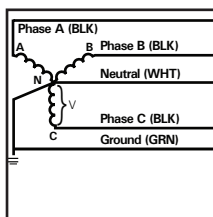

Figure 2

Wye
 3 Hots, 1 Neu, 1 Grnd

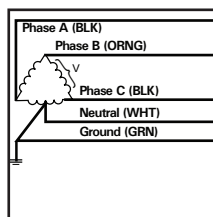

Figure 3

Hi-Leg Delta (B High)
 3 Hots, (B High),
 1 Neu, 1 Grnd

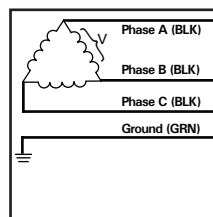

Figure 4

Delta & HRG Wye
 3 Hots, 1 Grnd

Notes:

- ① G voltage code only available in 200 & 250 kA
- ② Not available in 500 kA
- ③ Available in 100 kA, 150 kA, 200 kA & 250 kA only
- ④ VPR may increase when disconnect switch is added
 VPR may decrease for products 400 & 500 kA per phase
- ⑤ I_n rating for 100 - 300 kA per phase is 10 kA

Siemens Industry, Inc.

5400 Triangle Parkway
 Norcross, GA 30092

888-333-3545

info.us@siemens.com

Order No. RPFL-S306C-0716

Printed in USA

All Rights Reserved.

©2016 Siemens Industry, Inc.

TPS3 L6

True 10 Mode Protection

Type 1 / 2 Surge Protection Device (SPD) for Service Entrance Applications – SB1, SB2, SB3, Type RCS Switchboards, Type WL Low Voltage Switchgear, Motor Control Centers and Busway Systems

Features:

- Mounts internal to:
 - SB1, SB2, SB3 & Type RCS switchboards
 - Type WL low voltage switchgear
 - TIASTAR motor control centers - standard 12" bucket
 - STP series busplug on SX series busway
- UL 1449-4 Type 2 SPD, UL 1283 Listed, CSA 22.2 No. 269.2
- Optional UL 1449 4th Edition Listed Type 1, CSA 22.2 No. 269.1
- Type 1 / Type 2 SPD
- Large block, individually fused, thermally protected, 50 kA MOVs
- 20 kA I_n (most models)
- 200 kA SCCR (most models)
- Rotary disconnect switch included
- All UL required OCP & safety coordination included
 - Type 1 SPDs intended for Line or Load side of Main Disconnect
 - Type 2 SPDs intended for Load side of Main Disconnect
- UL96A Lightning Protection Master Label compliant (@20kA I_n)

- Designed, manufactured and tested consistent with:
 - ANSI/IEEE C62.41.1-2002, C62.41.2-2002, C62.45-2002, C62.62-2010, C62.72-2007 & CSA C22.2 No. 269.1 and .2
 - 1992/2000 NEMA LS-1
 - NEC Article 285
 - IEC 61643, CE
- 10 year warranty

SPD Specifications

- Directly connected discrete protection elements between all possible modes providing true 10 mode protection

Surge Current Rating Per Phase

Per Phase	L-N	L-G	L-L	N-G
150 kA	50 kA	50 kA	50 kA	50 kA
300 kA	100 kA	100 kA	100 kA	100 kA
450 kA	150 kA	150 kA	150 kA	150 kA

- 100% monitoring (Every MOV is monitored, incl. N-G)
- EMI/RFI filtering: Active tracking up to -50 db from 10 kHz to 100 MHz (Type 2 option only, includes UL 1283 Listing)
- Repetitive impulse: 5,000 hits
- Less than 1/2 nanosecond response time
- Relative humidity range: 1-95% non-condensing
- Operating frequency: 47-63 Hz
- Operating temperature: -25°C (-15°F) to +60°C (140°F)



- Applications
 - Provides main service entrance or downstream protection for sensitive computer and electronic loads
 - Std. redundancy use: 300kA/phase
 - Max. redundancy use: 450kA/phase

- SPD Monitoring
 - LED indicators
 - Audible alarm with silence switch and test button
 - Dry contacts
 - Surge counter
 - Rotary disconnect switch

Ordering Information

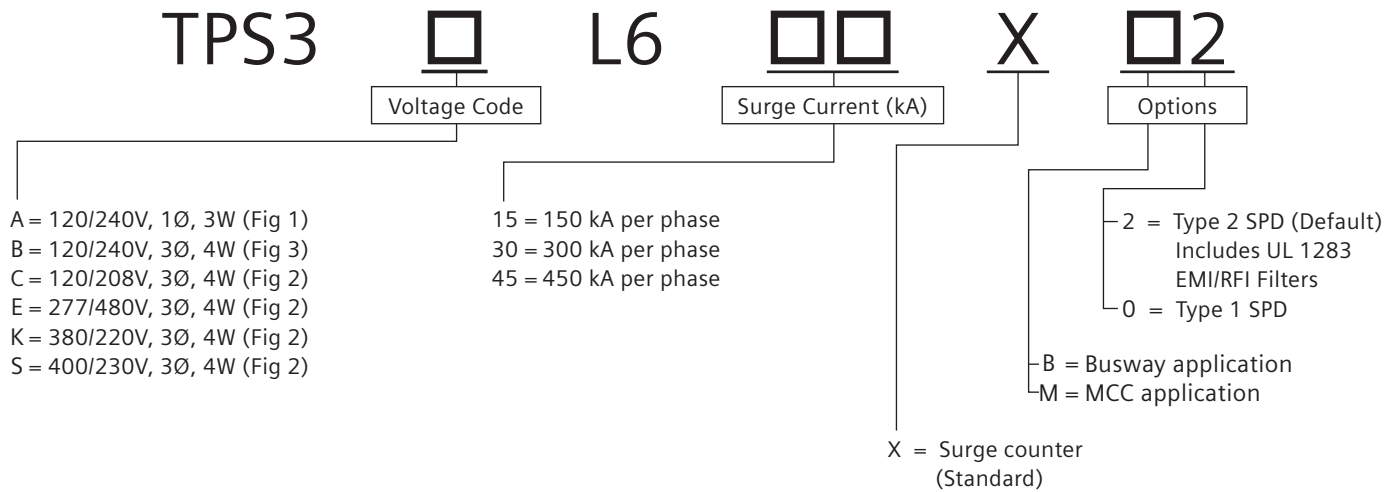

Example: TPS3CL645X02 = 10 mode Type 2 SPD (Default) for a 208/120V switchboard with a surge current capacity of 450 kA per phase and a surge counter

When an option is not selected, include a zero (0) in the field

**Available Accessories:
 Ordered Separately**
 RMSIE - Remote monitor

UL 1449 Fourth Edition - Test Data Voltage Protection Rating (VPR - 6 kV, 3 kA) ①

Voltage Code	Service Voltage	L-N	L-G	N-G	L-L	I _n	SCCR	MCOV
A	120/240V, 1Ø, 3W (Fig 1)	700	700	700	1000	20 kA	100 kA	150
B	120/240V, 3Ø, 4W (Fig 3)	800 / 1500	700 / 1200	700	1800/1800	20 kA	200 kA	150 / 275
C	120/208V, 3Ø, 4W (Fig 2)	700	700	700	1000	20 kA	200 kA	150
E	277/480V, 3Ø, 4W (Fig 2)	1200	1200	1200	1800	20 kA	200 kA	320
K	380/220V, 3Ø, 4W (Fig 2)	1200	1200	1200	1800	20 kA	200 kA	320
S	400/230V, 3Ø, 4W (Fig 2)	1200	1200	1200	1800	20 kA	200 kA	320

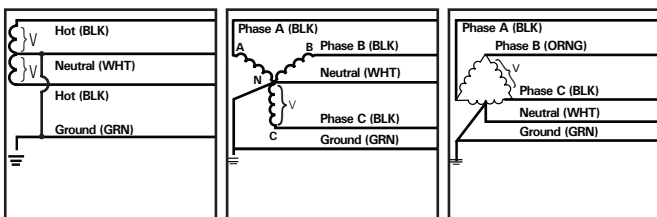

Notes:

- ① VPR may increase when disconnect switch is added
 VPR may decrease for 450 kA per phase

Siemens Industry, Inc.
 5400 Triangle Parkway
 Norcross, GA 30092
 888-333-3545
 info.us@siemens.com

Order No. RPFL-S3L6C-0716
 Printed in USA
 All Rights Reserved.
 ©2016 Siemens Industry, Inc.

Frequently Asked Questions

What is a Surge Protective Device or SPD?

A Surge Protective Device is a device that attenuates (reduces in magnitude) random, high energy, short duration overvoltages caused by lightning, utilities, switching, etc. Such anomalies occur in the form of voltage and current spikes with a duration of less than half an AC voltage cycle. These high energy power spikes can damage sensitive electronic equipment, such as computers, instrumentation, and process controllers.

How do SPDs work?

Surge Suppressors divert high energy power away from a load by providing a lower impedance path to common point earth ground. This is similar in concept to pressure relief valves that protect water heaters from overpressure. Surge suppressors used most often for protection of AC Power have metal oxide varistors (MOVs) connected in parallel.

Where are SPDs installed?

AC voltage surge suppressors are typically installed in these three areas: at a utility service entrance for protection of an entire facility, in distribution panelboards and switchboards for protection of sensitive downstream loads; connected to a wall outlet for individual protection of a specific piece of equipment, such as a computer or solid-state controller.

What is Clamping Voltage?

Clamping voltage, also referred to as peak let through or suppressed voltage rating, is the amount of voltage a surge suppressor permits to pass through it to the attached load during a transient event. Clamping voltage is a performance measurement of a surge suppressor's ability to attenuate a transient. For example, a surge suppressor might limit a 6,000V surge so that only 700V is 'visible' to the load. The Voltage Protection Rating is 700V, commonly called Clamping Voltage. This performance value is confirmed by Underwriters Laboratories during tests conducted while evaluating a surge suppressor for listing.

What is Surge Current Capacity?

Surge current capacity is the maximum amount of surge current that a surge suppressor can pass for a single transient event. This level is used to indicate the protection capacity of a particular surge suppressor design, and when specifying surge suppressors. For example, in a high exposure application with very large transients present from lightning, a higher level surge current capacity might be desired. Be aware that surges have natural limitations and that larger surge current capacity tends to add redundancy rather than the implied ability to handle an extremely large surge. For example, an entire lightning strike cannot go through wire; it is much like trying to put the output from a fire hose through a soda straw. Consequently, suppressors do not need to be sized for entire lightning strikes. There are valid reasons for adding excess surge current capacity for redundancy reasons.

What types of components make up a SPD?

The device most commonly used in AC voltage surge suppressors are MOVs, a solid-state device made of zinc oxide materials.

MOVs are voltage sensitive semiconductors, which change from high impedance to low impedance when sensing an overvoltage condition. MOVs are packaged for specific voltages and current handling capacities.

Other devices (more typically found in DC applications) include single junction diodes and gas tubes that ionize at preset voltages.

What features should be considered When selecting SPDs?

Two important areas to consider during the selection of a surge suppressor are performance and safety, and include the following criteria:

Performance: 1) surge current capacity; and 2) clamping voltage.

Safety: 1) the individual suppression circuit should be fused to clear an inoperative MOV during an extreme transient event, and 2) provide overcurrent protection for the surge suppressor during a fault condition.

What Surge Current Capacity is required?

Surge current capacity is dependent on the application and the amount of required protection. The selection of the proper surge suppressor is not an exact science and cannot be scientifically calculated from a standard algorithm.

Questions to consider when specifying the proper surge current capacity for a surge suppressor include:

- What is the geographic location of the facility and it's susceptibility to lightning? (For example, Florida is a high-lightning area; California is a low lightning area.)
- Is the facility in a rural or urban setting?
- Is the facility the tallest building around?
- Is the facility at the end of the utility grid?
- If it is an existing facility, what is its power quality history?

Based on the above information, and taking into account the cost of protection, the following is a good rule of thumb: a surge suppressor with a surge current capacity in the range of 100kA to 300kA would be used in conjunction with a service entrance panelboard or switchboard. A surge suppressor with a surge current capacity in the range of 100kA to 200kA would be used in conjunction with a downstream panelboard.

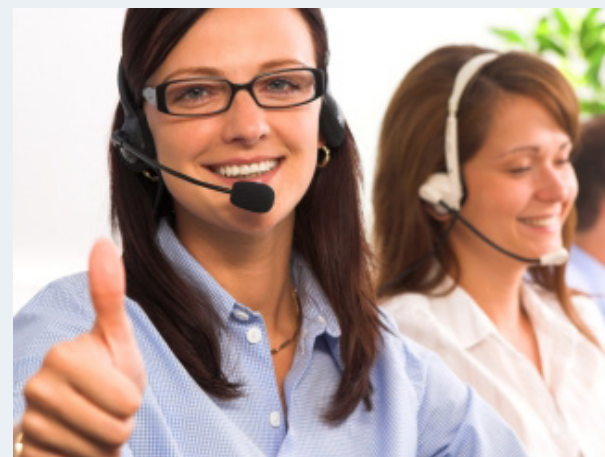

Siemens SPD Team Services and Support

Our Commitment to You

As our commitment to you, the Siemens SPD Team is here to assist you with all of your surge protection needs. Each region is designated with a highly trained representative to provide you with the best support possible.

Pre-Bid Support

- Over 1000 jobs are downloaded per month from the Electronic Plan Rooms, which provides us with complete take-offs, from drawings & specs.
- Notifications are sent to the Siemens Sales Engineer and Siemens distributor, listing the jobs bidding in your area.
- Detailed quotes with product information are sent to the Siemens Sales Engineer and Siemens distributor to enter into COMPAS or Industry Mall.
- Prior Approval Packages (PAPs) are sent on any jobs where Siemens Surge Protective Devices are not approved.
 1. Sending PAPs allow us to identify Consulting Engineers who specify Siemens gear but not Surge Protective Devices. This is done in an effort to gain approval.
 2. We have over 27 years of approval history documented in our proprietary database.

Post-Bid Support

Project Tracking to Conclusion

Electrical Contractor Award Notification

- After bid day, we determine which Electrical Contractor won the job.
- Electrical Contractor information is promptly sent to the Siemens Sales Engineer and Siemens Distributor to make sure they are the first to know.

Job Follow Up

- Ensures that you are competitively priced to win job.
- Shop Drawing Submittals are provided to Siemens Sales Engineer and Siemens Distributor.
- Engineering support is provided for any rejections or questions from Consulting Engineers.

Ongoing Support

- Customized Collaterals (i.e. flyers, handouts...)
- Design Guides
- Proper Product Selection Recommendations
- Competitor Product Comparison
- Specification Interpretation
- Webinars/Lunch & Learns
- On Site Visits
- Seminars at the Factory for CEU/PDH Credits
- 24/7 Online SPD Training via usa.siemens.com/step
- Troubleshooting
- Product Forensics
- Returns





Thank you...

for choosing Siemens for your surge protection needs.

Your technical support team is here to assist you.
(888) 333-3545

Learn more about our TPS3 Surge Protective Devices (SPDs) by visiting: Step 2000 - Basics of Surge Protection at usa.siemens.com/step.

usa.siemens.com/spd

Siemens Industry, Inc.
5400 Triangle Parkway
Norcross, GA 30092

For more information, please contact our Customer Support Center.

Phone: +1 888 333 3545
Fax: +1 727 539 8955
E-mail: info.us@siemens.com
Web: usa.siemens.com/spd

Article-No. RPCA-SPDCA-1216
Printed in USA
All rights reserved
© 2016, Siemens Industry, Inc.

The information provided in this manual contains merely general descriptions of characteristics of performance which in case of actual use do not always apply as described or which may change as a result of further development of the product. An obligation to provide the respective characteristics shall only exist if expressly agreed in the terms of contract.

All product designations may be trademarks or product names of Siemens AG or supplier companies whose use by third parties for their own purposes could violate the rights of the owners.

