

PVC-Coated Strut and Accessories

Corrosion-protected clamps for hanging threaded rod.

Ocal® PVC-Coated Hanger Rod Beam Clamps

- Malleable iron construction
- Nominal .015" (15 mil) PVC coating in blue, white, gray or custom colors
- 500, 502 and 503 also available uncoated in Type 316 stainless steel; add -SS316 to catalog number to order (for example: 502-SS316)

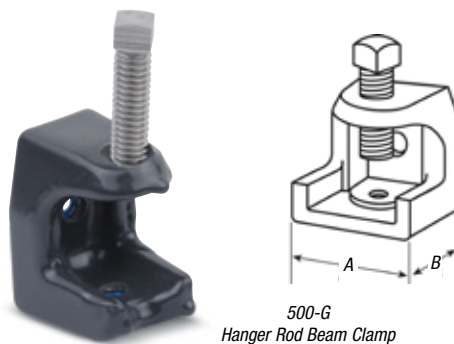

Cat. No.	Color
500-	
_ = space for color identifier	
G = Gray	
W = White	
B = Blue	
Custom colors also available.	

CAT. NO.	BASE "A" IN. MM	BASE "B" IN. MM	JAW OPENING IN. MM	TAPPED HOLE IN. MM	LOAD RATING† LBS. KG
500- 1	25.40	31.75	1 ¹ / ₄	1/4 - 20	450 204.12
501- 1	38.10	41.28	1 ¹ / ₈	3/16 - 18	800 362.87
502- 2	50.80	50.80	1	3/8 - 16	1300 589.67
503- 2	66.68	63.50	1	1/2 - 13	1300 589.67
508- 2	63.50	60.33	2	1/2 - 13	1700 771.11

* Metric size designator (ANSI C80.1-1994).
 † Load ratings based on bottom hole of beam clamp with safety factor of three.
 CSA File No. LR-52208

Includes stainless steel bolt and nut for fast, easy installation.

Ocal® PVC-Coated Mini Conduit Hangers

- Nominal .015" (15 mil) PVC coating in blue, white, gray or custom colors
- Rated for loads of up to 500 lbs. (226.80kg) with a safety factor of three



MINE3/4-G
Mini Conduit Hanger

Cat. No.	Color
MINE1-	
_ = space for color identifier	
G = Gray	
W = White	
B = Blue	
Custom colors also available.	

CAT. NO.	PIPE SIZE IN. METRIC SIZE DESIGNATOR*
MINE1/2- 1	1/2 16
MINE3/4- 1	3/4 21
MINE1- 1	1 27
MINE1-1/4- 1	1 ¹ / ₄ 35
MINE1-1/2- 1	1 ¹ / ₂ 41
MINE2- 2	2 53
MINE2-1/2- 2	2 ¹ / ₂ 63
MINE3- 3	3 78
MINE3-1/2- 3	3 ¹ / ₂ 91
MINE4- 4	4 103

* Metric size designator (ANSI C80.1-1994).