

PROAIR HARSH ENVIRONMENT

CR23
1600 BTU/Hr.
469 Watt



CR29
2700 and 4000 BTU/Hr.
791 and 1172 Watts



CR43
6000 & 8000 BTU/Hr.
1758 and 2344 Watts

INDUSTRY STANDARDS

UL/cUL Listed; Type 12, 3R, 4; 4X optional; File No. SA6453
UR/cUR Recognized

UR/cUR Recognized on select models, reference performance data tables.

CE
EAC

APPLICATION

- Industrial automation
- Package handling equipment
- Food and beverage
- Wastewater treatment
- Security and defense systems
- And more

FEATURES

- Robust reciprocating compressor
- Easy maintenance: hinged front cover allows quick access to all components; condenser coil can be cleaned while unit is still mounted to the cabinet
- R134a or R407c earth-friendly refrigerant
- Models for 115, 230 and 460 single phase VAC power input
- UL Listed or Recognized to save customers time and money with agency approvals
- Operating temperature range from -40 F/-40 C to 131 F/55 C (with optional low-ambient package)
- Attractive industrial design with minimal use of visible fasteners
- Reliable mechanical thermostat located behind the filter of the unit

- Low-carbon mild-steel sheet-metal cover for rugged factory and outdoor environments
- Easy-mount flanges for simple installation
- Cleanable reusable aluminum mesh filter protects coils for maximum cooling performance
- Mounting hardware, gaskets and user manual furnished with the unit
- Every unit functionally tested before shipping
- High-performance fans and blowers designed for densely packed enclosures
- Standard Indoor Air Conditioner models also include:
 - Electro-Mechanical Thermostat
 - Surge Suppressor

FINISH

- RAL 7035 light-gray, semi-textured powder-coat paint standard
- Stainless steel Type 304 or 316 finishes available on Type 4X models
- Other colors and textures available

OPTIONS

- Thermostat Malfunction Package
- Special Voltage Package
- Outdoor Package*
- Harsh Environment Package*
- Stainless Steel Package*
- Heater Package*

* T-Series may be more appropriate. Refer to T-Series A/C section. Consult the factory for availability and catalog number.

Performance Data **CR23 Models 1600 BTU/Hr. (469 Watt)**

CATALOG NUMBER			
Indoor Model	CR230216G002	CR230226G002	CR230246G400
Indoor Level 2 Controller	CR230216G016	—	—
Outdoor Type 3R	CR230216G013	CR230226G030	—
Outdoor/SST/Corrosion Type 3R	CR230216G007	CR230226G009	—
Outdoor/SST/Level 2 Type 3R	CR230216G017	CR230226G016	—
Indoor/Outdoor/SST/Corrosion Type 4X	CR230216G015	CR230226G014	CR230226G037
COOLING PERFORMANCE			
Nominal:			
BTU/Hr.	1400/1600	1400/1600	1400/1600
Watts	410/469	410/469	410/469
Refrigerant	R-134A	R-134A	R-134A
Refrigerant Charge (ounces/grams)	10/284	10/284	10/284
Operating Temperature Range:			
Maximum (°F/°C)	131/55	131/55	131/55
Minimum (°F/°C) (Low Ambient Pkg)	-40/-40	-40/-40	-40/-40
Airflow at 0 Static Pressure:			
Internal loop 50 Hz (CFM / m ³ /hr.)	117/199	117/199	117/199
External loop 50 Hz (CFM / m ³ /hr.)	86/146	86/146	86/146
Internal loop 60 Hz (CFM / m ³ /hr.)	130/221	130/221	130/221
External loop 60 Hz (CFM / m ³ /hr.)	95/161	95/161	95/161
ELECTRICAL DATA			
Rated Voltage	115	230	460V 1PH
Frequency (Hz)	50/60	50/60	50/60
Operating Range	+/- 10%	+/- 10%	+/- 10%
Max. Power Consumption (W at 50/60 Hz)	471.5/517.5	506	552
Max. Nominal Current (A at 50/60 Hz)	4.1/4.0	2.7/2.5	1.4/1.3
Starting Current (A)	18	13.2	7.7
Agency Approvals	UL/cUL Listed CE EAC		cUR Recognized CE EAC
Power Input Description	6-ft. cord with NEMA 5-15 plug	6-ft. cord with NEMA 6-15 plug	6-ft. cord with wire leads
ENCLOSURE PROTECTION			
UL Type	Type 12, 3R standard Type 4, 4X Stainless steel optional		
CONTROLLER			
Description	Basic mechanical thermostat		
Thermostat Location	Behind cover		
Factory Thermostat Setting (°F/°C)	80/27		
SOUND LEVEL			
At 1.5 Meters	62 dB(A)		
UNIT CONSTRUCTION			
Material	Mild steel sheet metal standard Stainless steel optional		
Finish	RAL 7035 light-gray, semi-textured powder-coat paint standard		
UNIT DIMENSIONS			
Height (in./mm)	23/584		23/584
Width (in./mm)	10/254		10/254
Depth (in./mm)	8.75/222		8.75/222
Weight (lb./kg)	57/26		67/30

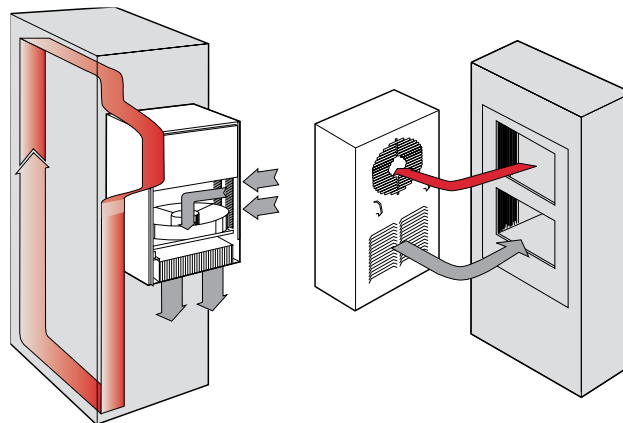

CR23 Models 1600 BTU/Hr. (469 Watt)

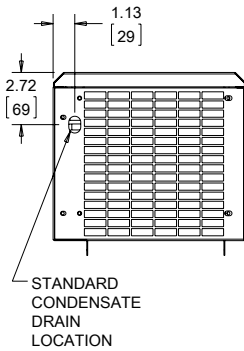
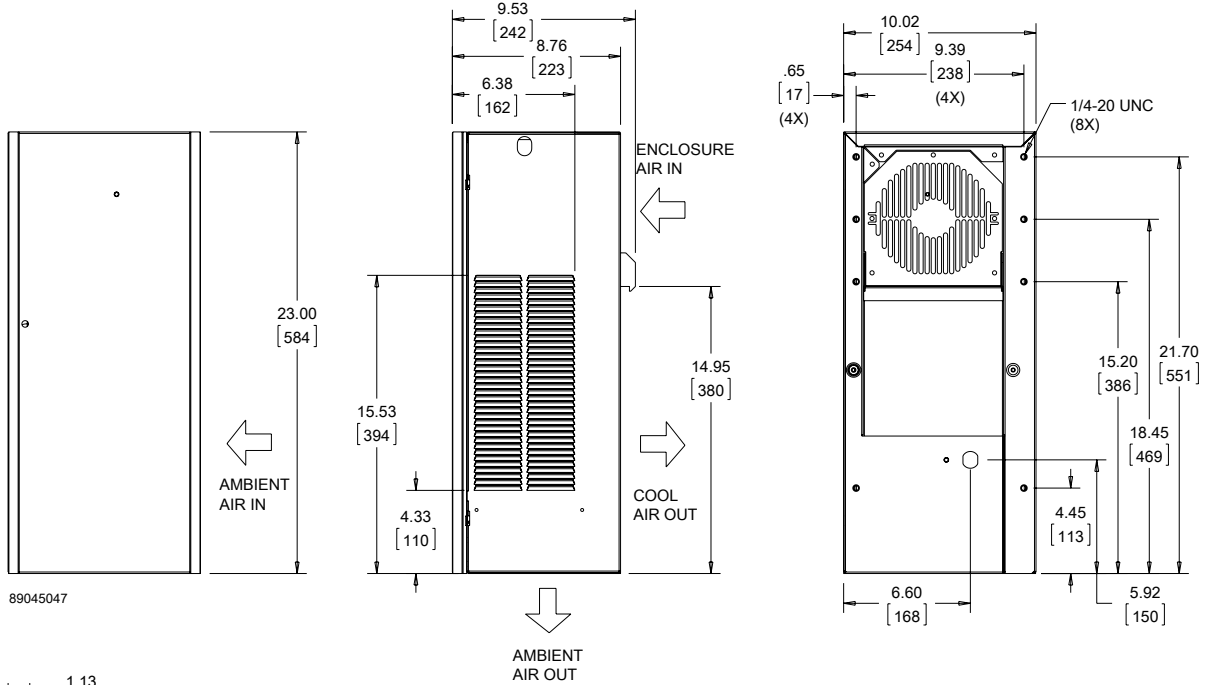
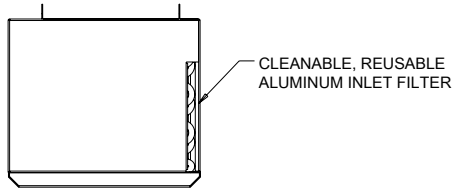

NOTE:
 1. MOUNTING GASKET SUPPLIED (NOT SHOWN)
 2. UNITS: in. [mm]

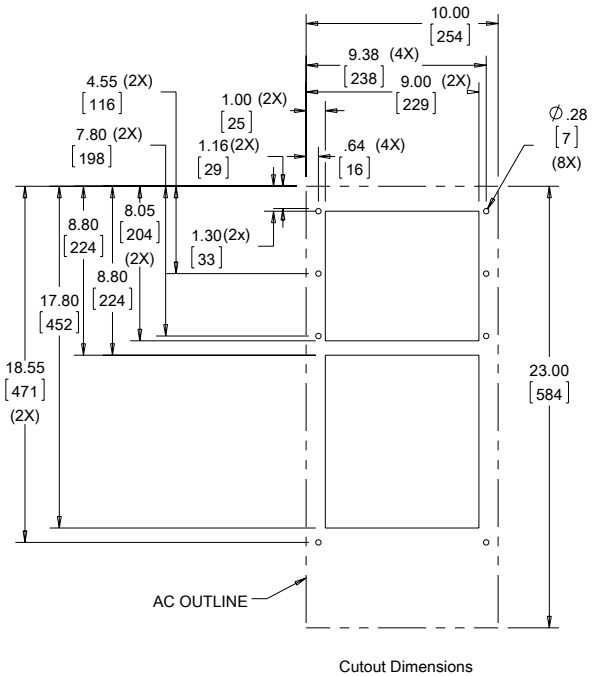

Visit nVent.com/HOFFMAN to download 2D and 3D CAD drawings into the overall design of your electrical system.

CR23 Models 1600 BTU/Hr. (469 Watt) With Type 4X Hood

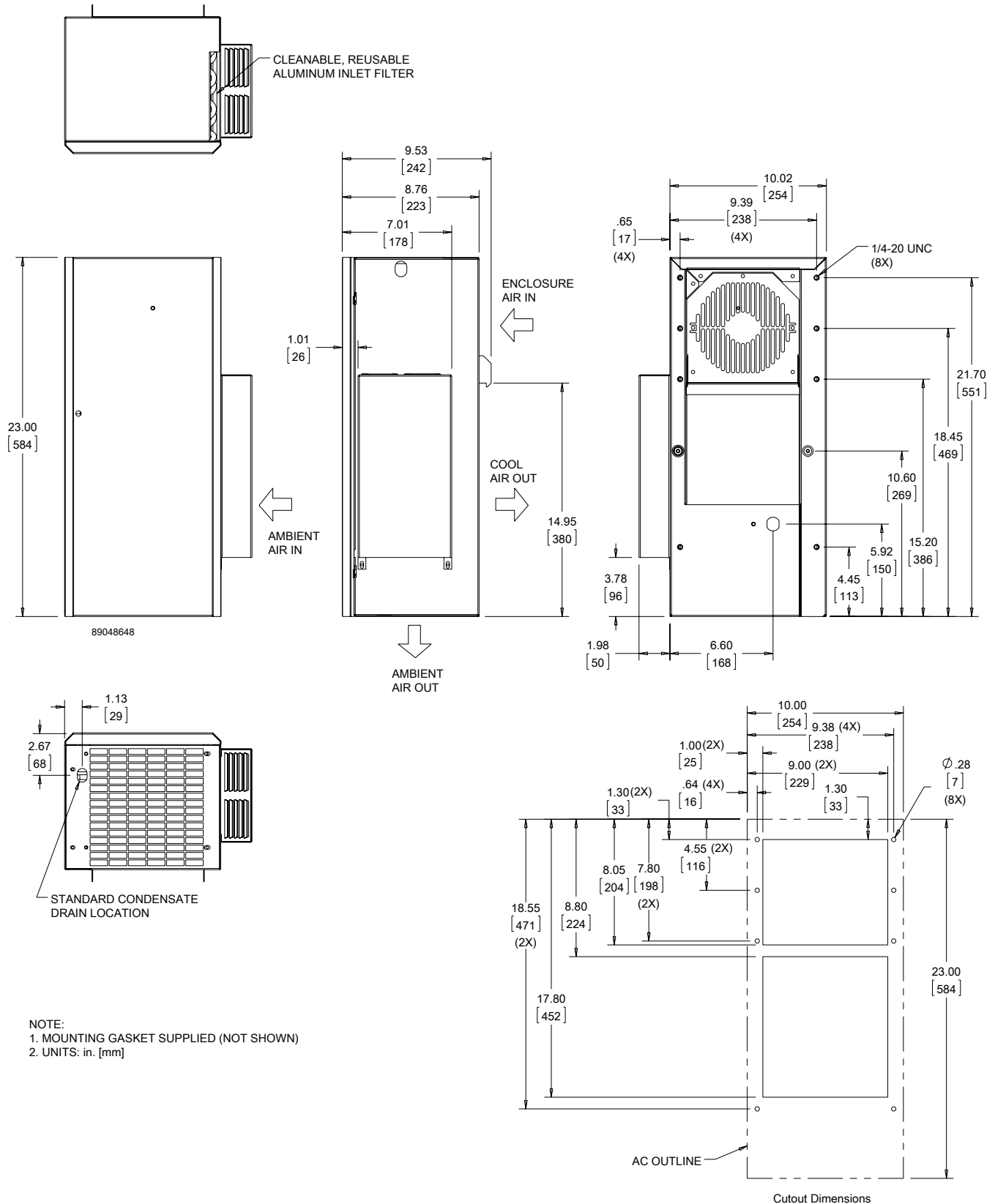

Visit nVent.com/HOFFMAN to download 2D and 3D CAD drawings into the overall design of your electrical system.